

PIVOTPOINT[®] INC.

PINS > CABLES > SOLUTIONS

Stock & Specials!



NEW PATENTS & INNOVATIONS
Since 1929!



WIRE ROPE LANYARDS
Per Your Imagination!



CUSTOM ENGINEERING
Our Specialty!



Get quote >>

Table of Contents

Check out our Custom-Engineered Fastening Solutions 26-27

Our Specialty! We'll work with you to develop the ideal fastener solution to suit your specific application; we'll also provide preliminary prints and samples. We love a challenge, so let us help you develop the perfect solution!

Precision Machined Components 5

 Precision Machined Components 5

Cold Heading Solutions 6-13

 SLIC Pins™ 6-7

 Clevis Pins 8-11

 Detent Clevis Pins 12

 Lynch Pins 12

 Wire Lock Pins 13

 Tab Lock Pins 13

Quick Release Solutions 14-20

 Detent Ring Pins 14-15

 Ball Lock Pins 16-17

 Auto Lock Safety Pull Pins 18

 Pull Pins 19

 Ball Plungers/Spring Loaded Devices 20

Screw Machine Solutions 21-22

 Ring Pins 21

 Bent Arm Pins 22

 Headless Pins 22

Cable Assembly Solutions 23-25, 28-35

 Push-Pull Control Cables 23

 Stock Wire Rope Lanyards 24-25

 Custom Wire Rope Lanyards 28

 End Fittings 29-32

 Carabiners 32

 Bulk Cable 33

 Cable Cutter & Crimp Tool 33

Injection Molding Solutions 34-35

 Nylon Lanyards™ 34-35

 Press Lock Rivets 35

Wire Forming Solutions 36-43

 Bow-Tie Locking Cotters™ 36-37

 Rue Ring™ Locking Cotters 38-39

 Hair Pin Cotters 40

 Double Loop Hairpin Cotters 41

 Infinity S-Hooks™ 41

 S-Hooks 42

 Circle Cotters 43

 Kickout Rings 43

Additional Fastening Solutions 44-46

 Split Key Rings 44

 Basic Rings 44

 Crimp Ring Retainers 45

 Cable Ties 46

General Information 47-49

Mechanical Properties of Steel 47

Chemical Composition 48

Fastener Plating & Finishes 48

Glossary of Terms 49

Sales Terms & Conditions 50



PRECISION MADE
in the
U.S.A.



UNITED STATES PATENT
PATENTED
TRADEMARK OFFICE



Our Exclusive Innovation

Pivot Point is proud to manufacture the majority of our fasteners in the U.S.A. We hold several U.S. and Foreign Patents and offer other fasteners made with our exclusive design innovations. Look for these icons to identify our innovative solutions!

ISO CERTIFIED
Version 9001
Certificate C0236776-IS1

You can be assured of superior part quality, and our compliance to ISO 9001 means we deliver quality throughout - from order entry to shipment. We diligently maintain our certification.
(Certificate C0236776-IS1)



Get quote »



pi **Angic Global Solutions**
1-888-872-0690
<https://www.AngicGlobal.com> Sales@AngicGlobal.com



New from Pivot Point: Precision Machined Components

Pivot Point manufactures Precision Machined Components in a variety of configurations to suit your applications. High speed swiss-style machining affords complex, precise parts in one operation. Numerous live tools allow for multiple operations on a single part.

Common materials and part features include:

- Carbon Steel
- Alloy Steel
- Stainless Steel
- Aluminum
- Brass
- Drilling
- Grooving
- Tapping
- Threading
- Milling



MADE TO
ORDER



Get quote »



pi Angic Global Solutions



1-888-872-0690

<https://www.AngicGlobal.com> Sales@AngicGlobal.com

It's a Pin & Cotter All In One!



SLIC Pins™

U.S. Patent No. 6,872,039 &
No. 7,147,420
Foreign Patents Issued



The Self Locking Implanted Cotter Pin is a pin and cotter all in one!

Strong spring-loaded plunger features easy insertion ramp and the vertical face at the rear prevents backing out. This patented design is ideal for holes where cotter pin access is limited.

The SLIC Pin™ eliminates cotters, bolts and nuts and does not require tools for use - thereby greatly speeding assembly times. It is well suited for automated assembly and is easier, safer and faster.

Cost Saving Quick-Locking Secure

Spring-loaded plunger retracts when inserted, then locks into place.

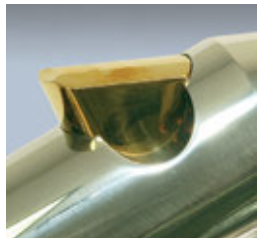

SLIC PIN ADVANTAGES

- Pin and cotter all in one
- Eliminates cotters, bolts, nuts
- Ideal for holes where cotter pin access is limited
- Easier, safer, faster assembly
- Well suited for automated assembly
- No tools needed



Now available in two different plunger options!

Removable Plunger

Features a rounded top, affording easier removal in assemblies with slight gaps when the pin needs to be removed.

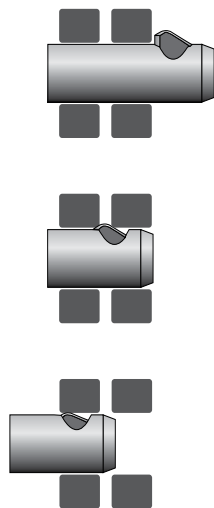

Standard Plunger

Features a more sharply angled top, affording greatest capture height of the plunger. Use for semi-permanent fastening, where the pin is seldom removed.

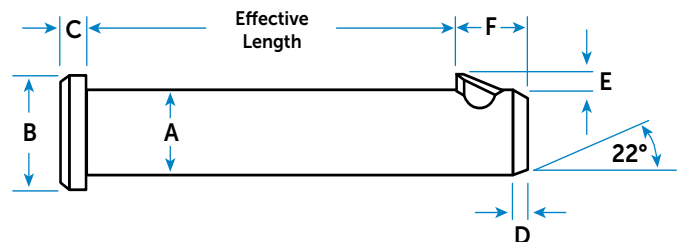
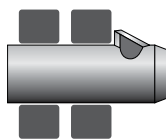

SLIC Pin - Standard Specs (modify if necessary)

Basic Shank Diameter	Effective Length	Shank Diameter A	Head Diameter B	Head Height C	Chamfer D	Approx. Plunger Height E	F (Standard)	F (Min. available) End chamfer is eliminated
3/16	as required	.181 - .186	.31	.06	.040 x 22°	.035	.173	.133
1/4	as required	.243 - .248	.37	.09	.055 x 22°	.049	.225	.170
5/16	as required	.306 - .311	.43	.09	.065 x 22°	.062	.281	.216
3/8	as required	.368 - .373	.50	.12	.070 x 22°	.075	.338	.268
7/16	as required	.431 - .436	.56	.15	.070 x 22°	.075	.338	.268
1/2	as required	.491 - .496	.62	.15	.090 x 22°	.082	.400	.310
5/8	as required	.616 - .621	.81	.20	.115 x 22°	.082	.425	.310
3/4	as required	.741 - .746	.93	.25	.115 x 22°	.082	.425	.310
Metric Sizes								
6 mm	as required	5.93 - 6.00	10 mm	2 mm	1.4 mm x 22°	1.2 mm	5.72 mm	4.32 mm
8 mm	as required	7.91 - 8.00	14 mm	3 mm	1.7 mm x 22°	1.62 mm	7.13 mm	5.48 mm
10 mm	as required	9.91 - 10.00	18 mm	4 mm	1.8 mm x 22°	1.89 mm	8.59 mm	6.81 mm
12 mm	as required	11.90 - 12.00	20 mm	4 mm	2.3 mm x 22°	2.10 mm	10.15 mm	7.86 mm

Unless otherwise noted, all dimensions are for reference only.

Contact us for samples and more information.

SLIC Pins™ *Made to Your Specifications*

- Special plunger shapes
- Different pin/head styles
- Various finishes
- Steel, alloy, stainless, aluminum, brass & more



Double Plunger Option

For use in certain applications, such as those with short effective lengths. (For pin diameters 9/16" and up)

Contact us for more information.

Design your SLIC Pin online!

- Configure and download a 3D rendering of a SLIC Pin™ to your specs
- Request a quote

The SLIC Pin in Action:

Use in place of cotters or clips

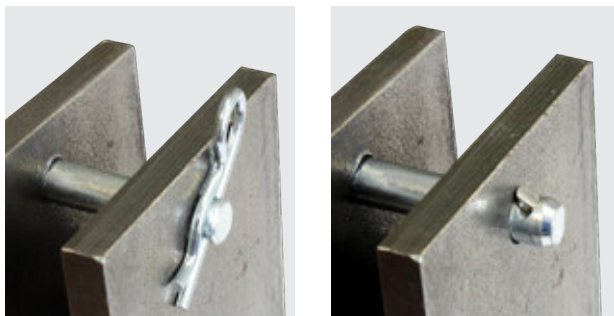

Quick connection with cable mechanism



Use as a standoff for quick connecting

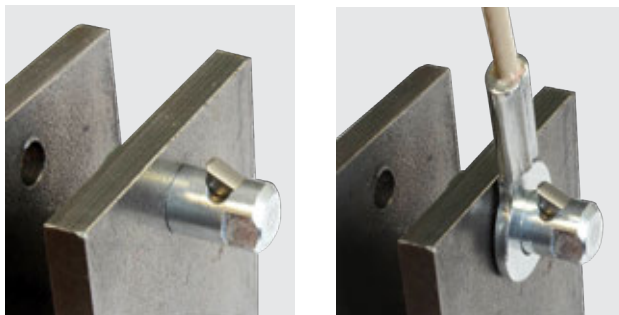

Watch the demonstration video online:



Patent Information:

US Patent No's. 6,872,039 & 7,147,420; GB 1471266
FR 1471266; DE 602004022890.7; ES 30339/BE/2009; IT 1471266



Get quote >>



Angic Global Solutions

1-888-872-0690

<https://www.AngicGlobal.com> Sales@AngicGlobal.com

Manufactured In-House

Clevis Pins

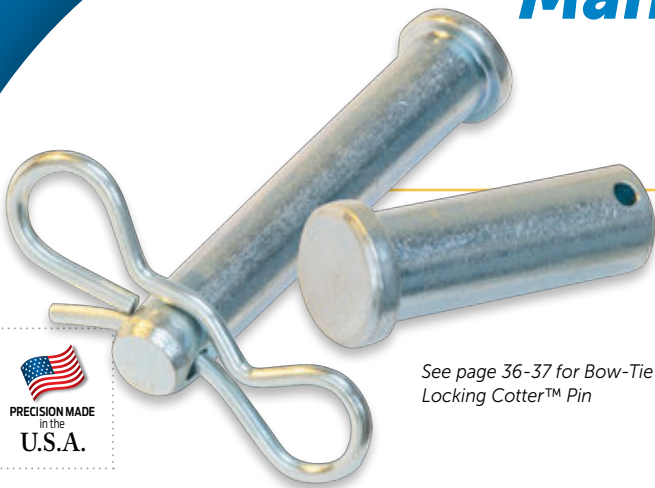

See page 36-37 for Bow-Tie Locking Cotter™ Pin

Pivot Point manufactures clevis pins in-house. Stock pins are cold headed per IFI standards except do not have an end chamfer and have slightly different hole sizing. See chart below. All holes are chamfered for a superior part finish.

Only the finest cold heading quality wire is used. Standard clevis pins are manufactured in low carbon steel or stainless type 302, and stocked plain finish. Holes are drilled per Pivot Point specifications.

Special clevis pins and grades are available. Pivot Point stocks alloy material to produce up to grade 8 strength, if required. Aluminum and other materials are also available. Secondary heat treatment, plating, grooving and end chamfering available.

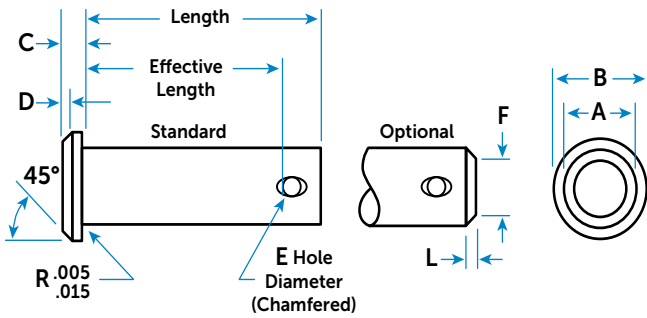

Alternate Head Styles

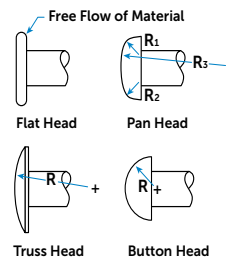

Standard Hole Location

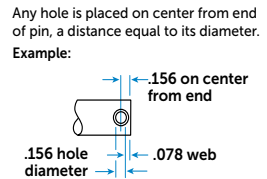

Clevis Pin Specs

Basic Shank Diameter	Shank Diameter A	Head Diameter B	Head Height C	Head Chamfer D	Pivot Point Std. Hole E	Optional Dimensions Per J493			
						Hole Dia. E	Point Dia. F	Point Length L	
3/16	.181 - .186	.31	.06	.02	3/32	5/64	.14	.045	
1/4	.243 - .248	.37	.09	.03	3/32	5/64	.20	.045	
5/16	.306 - .311	.43	.09	.03	1/8	7/64	.25	.060	
3/8	.368 - .373	.50	.12	.03	5/32	7/64	.32	.060	
7/16	.431 - .436	.56	.15	.04	5/32	7/64	.38	.060	
1/2	.491 - .496	.62	.15	.04	5/32	9/64	.43	.076	
5/8	.616 - .621	.81	.20	.06	5/32	9/64	.55	.076	
3/4	.741 - .746	.93	.25	.07	5/32	11/64	.67	.093	
Metric Sizes	6 mm	5.93 - 6.00	10 mm	2 mm	1 mm	1.6 mm	1.6 mm	4 mm	1.7 mm
	8 mm	7.91 - 8.00	14 mm	3 mm	1 mm	2 mm	2 mm	6 mm	1.7 mm
	10 mm	9.91 - 10.00	18 mm	4 mm	1 mm	3.2 mm	3.2 mm	8 mm	1.7 mm
	12 mm	11.90 - 12.00	20 mm	4 mm	1.5 mm	3.2 mm	3.2 mm	9 mm	2.6 mm

STAINLESS STOCKED!

Select sizes stocked in 302 stainless. See stock listing below. Other stainless sizes available on a made-to-order basis.



Clevis Pins

	STOCK CODE Carbon Steel Plain Finish	STOCK CODE Stainless Steel Plain Finish	STOCK SIZES (diameter x length)	APPROXIMATE LENGTH UNDER HEAD		HOLE SIZE	Approximate Weight/Pounds per 100 Pieces
				To Edge of Hole (effective length)	To Center of Hole		
3/16	CP-2	CP-2SS	3/16 x 1/2	.359	.406	3/32	.45
	CP-4		3/16 x 19/32	.453	.500		.53
	CP-6	CP-6SS	3/16 x 5/8	.484	.531		.58
	CP-8	CP-8SS	3/16 x 3/4	.609	.656		.63
	CP-10	CP-10SS	3/16 x 7/8	.734	.781		.74
	CP-12	CP-12SS	3/16 x 1	.859	.906		.82
	CP-14	CP-14SS	3/16 x 1-1/4	1.109	1.156		1.03

Clevis Pins continued on page 9





Continued from page 8

Clevis Pins

	STOCK CODE Carbon Steel Plain Finish	STOCK CODE Stainless Steel Plain Finish	STOCK SIZES (diameter x length)	APPROXIMATE LENGTH UNDER HEAD		HOLE SIZE	Approximate Weight/Pounds per 100 Pieces
				To Edge of Hole (effective length)	To Center of Hole		
3/16	CP-16	CP-16SS	3/16 x 1-1/2	1.359	1.406	3/32	1.22
	CP-18		3/16 x 1-3/4	1.609	1.656		1.39
	CP-20		3/16 x 2	1.859	1.906		1.59
	CP-22		3/16 x 2-1/2	2.359	2.406		1.93
1/4	CP-24		3/16 x 3	2.859	2.906		2.44
	CP-26	CP-26SS	1/4 x 1/2	.359	.406	3/32	.90
	CP-28	CP-28SS	1/4 x 5/8	.484	.531		1.04
	CP-30	CP-30SS	1/4 x 3/4	.609	.656		1.20
	CP-32		1/4 x 51/64	.656	.703		1.27
	CP-34		1/4 x 7/8	.734	.781		1.40
	CP-36	CP-36SS	1/4 x 1	.859	.906		1.54
	CP-38	CP-38SS	1/4 x 1-1/8	.984	1.031		1.75
	CP-40	CP-40SS	1/4 x 1-1/4	1.109	1.156		1.87
	CP-42		1/4 x 1-3/8	1.234	1.281		2.02
	CP-44	CP-44SS	1/4 x 1-1/2	1.359	1.406		2.22
	CP-46		1/4 x 1-5/8	1.484	1.531		2.35
	CP-48		1/4 x 1-3/4	1.609	1.656		2.56
	CP-50	CP-50SS	1/4 x 1-7/8	1.734	1.781		2.75
	CP-52	CP-52SS	1/4 x 2	1.859	1.906		2.86
	CP-54	CP-54SS	1/4 x 2-1/8	1.984	2.031		3.10
	CP-56	CP-56SS	1/4 x 2-1/4	2.109	2.156		3.23
	CP-62		1/4 x 2-1/2	2.359	2.406		3.56
	CP-66		1/4 x 2-3/4	2.609	2.656		3.83
	CP-68		1/4 x 3	2.859	2.906		4.13
CP-70		1/4 x 3-1/2	3.359	3.406		4.87	
CP-72		1/4 x 4	3.859	3.906		5.44	
5/16	CP-76		5/16 x 1/2	.313	.375	1/8	1.43
	CP-78	CP-78SS	5/16 x 3/4	.563	.625		1.87
	CP-80		5/16 x 7/8	.688	.750		2.16
	CP-82		5/16 x 31/32	.781	.844		2.35
	CP-84	CP-84SS	5/16 x 1	.813	.875		2.43
	CP-86		5/16 x 1-1/8	.938	1.000		2.71
	CP-88		5/16 x 1-3/16	1.000	1.063		2.84
	CP-90	CP-90SS	5/16 x 1-1/4	1.063	1.125		2.92
	CP-92		5/16 x 1-3/8	1.188	1.250		3.17
	CP-94	CP-94SS	5/16 x 1-1/2	1.313	1.375		3.44
	CP-100		5/16 x 1-3/4	1.563	1.625		3.98
	CP-104		5/16 x 1-7/8	1.688	1.750		4.28
	CP-108	CP-108SS	5/16 x 2	1.813	1.875		4.51
	CP-110		5/16 x 2-1/8	1.938	2.000		4.73
3/8	CP-114		5/16 x 2-1/4	2.063	2.125		5.06
	CP-116		5/16 x 2-3/8	2.188	2.250		5.31
	CP-118	CP-118SS	5/16 x 2-1/2	2.313	2.375		5.47
	CP-120		5/16 x 2-5/8	2.438	2.500		5.79
	CP-122		5/16 x 2-3/4	2.563	2.625		6.08
	CP-128	CP-128SS	5/16 x 3	2.813	2.875		6.52
	CP-134		5/16 x 3-1/2	3.313	3.375		7.60
	CP-136		5/16 x 4	3.813	3.875		8.61
	CP-140	CP-140SS	3/8 x 3/4	.516	.594	5/32	2.79
	CP-142	CP-142SS	3/8 x 1	.766	.844		3.51
CP-144		3/8 x 1-3/32	.859	.938		3.89	



Clevis Pins continued on page 10



Get quote »



Angic Global Solutions

1-888-872-0690

<https://www.AngicGlobal.com> Sales@AngicGlobal.com

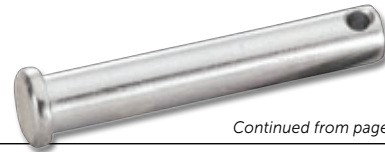

Continued from page 9

Clevis Pins

STOCK CODE Carbon Steel Plain Finish	STOCK CODE Stainless Steel Plain Finish	STOCK SIZES (diameter x length)	APPROXIMATE LENGTH UNDER HEAD		HOLE SIZE	Approximate Weight/Pounds per 100 Pieces
			To Edge of Hole (effective length)	To Center of Hole		
CP-146		3/8 x 1-1/8	.891	.969	5/32	3.98
CP-148	CP-148SS	3/8 x 1-1/4	1.016	1.094		4.33
CP-150		3/8 x 1-5/16	1.078	1.156		4.48
CP-152		3/8 x 1-3/8	1.141	1.219		4.66
CP-154	CP-154SS	3/8 x 1-1/2	1.266	1.344		5.06
CP-156		3/8 x 1-5/8	1.391	1.469		5.37
CP-158		3/8 x 1-3/4	1.516	1.594		5.84
CP-160	CP-160SS	3/8 x 1-7/8	1.640	1.719		6.19
CP-162	CP-162SS	3/8 x 2	1.766	1.844		6.50
CP-164		3/8 x 2-1/8	1.891	1.969		6.96
CP-166		3/8 x 2-1/4	2.016	2.094		7.13
CP-168		3/8 x 2-3/8	2.141	2.219		7.58
CP-170		3/8 x 2-1/2	2.266	2.344		8.08
CP-172		3/8 x 2-5/8	2.391	2.469		8.36
CP-174		3/8 x 2-3/4	2.516	2.594		8.70
CP-176		3/8 x 3	2.766	2.844		9.48
CP-178		3/8 x 3-1/4	3.016	3.094		10.44
CP-180		3/8 x 3-1/2	3.266	3.344		11.20
CP-182		3/8 x 3-3/4	3.516	3.594		11.90
CP-184		3/8 x 4	3.766	3.844		12.54
CP-188		7/16 x 1	.766	.844		5.05
CP-190		7/16 x 1-15/64	1.000	1.078		6.01
CP-192		7/16 x 1-1/4	1.016	1.094		6.07
CP-194		7/16 x 1-1/2	1.266	1.344		7.14
CP-198		7/16 x 1-3/4	1.516	1.594		8.20
CP-200		7/16 x 2	1.766	1.844		9.19
CP-202		7/16 x 2-1/4	2.016	2.094		10.43
CP-206		7/16 x 2-1/2	2.266	2.344		11.30
CP-212		7/16 x 3	2.766	2.844		13.40
CP-214		7/16 x 3-1/2	3.266	3.344		15.24
CP-216		7/16 x 4	3.766	3.844		17.24
CP-218	CP-218SS	1/2 x 1	.766	.844		6.32
CP-220		1/2 x 1-1/4	1.016	1.094		7.77
CP-222		1/2 x 1-27/64	1.188	1.266		8.61
CP-224		1/2 x 1-1/2	1.266	1.344		9.00
CP-226		1/2 x 1-3/4	1.516	1.594		10.38
CP-228		1/2 x 2	1.766	1.844		12.88
CP-230		1/2 x 2-1/4	2.016	2.094		13.02
CP-232		1/2 x 2-1/2	2.266	2.344		14.32
CP-234		1/2 x 2-5/8	2.391	2.469		15.14
CP-236		1/2 x 2-3/4	2.516	2.594		15.68
CP-238		1/2 x 3	2.766	2.844		17.08
CP-240		1/2 x 3-1/2	3.266	3.344		19.74
CP-242		1/2 x 4	3.766	3.844		22.36
CP-244		1/2 x 4-1/2	4.266	4.344		24.96
CP-246		1/2 x 5	4.766	4.844		27.60
CP-258		5/8 x 1-1/4	1.016	1.094		13.30
CP-260		5/8 x 1-1/2	1.266	1.344		15.32
CP-262		5/8 x 1-3/4	1.516	1.594		17.60
CP-264		5/8 x 2	1.766	1.844		19.26
CP-266		5/8 x 2-1/4	2.016	2.094		21.64

Clevis Pins continued on page 11



3/8
7/16
1/2
5/8



Continued from page 10

Clevis Pins

	STOCK CODE Carbon Steel Plain Finish	STOCK CODE Stainless Steel Plain Finish	STOCK SIZES (diameter x length)	APPROXIMATE LENGTH UNDER HEAD		HOLE SIZE	Approximate Weight/Pounds per 100 Pieces
				To Edge of Hole (effective length)	To Center of Hole		
5/8	CP-268		5/8 x 2-1/2	2.266	2.344	5/32	23.82
	CP-270		5/8 x 3	2.766	2.844		28.04
	CP-272		5/8 x 3-1/2	3.266	3.344		32.20
	CP-274		5/8 x 4	3.766	3.844		36.06
3/4	CP-284		3/4 x 2	1.766	1.844		28.78
	CP-286		3/4 x 2-1/2	2.266	2.344		34.90
	CP-290		3/4 x 3	2.766	2.844		41.34
	CP-296		3/4 x 4	3.766	3.844		53.32



Choose a Clevis Pin

Manufactured to your drawing and specifications!



- Grooving
- End Chamfering
- Ball Detenting
- Other Head Styles
- Special Hole Sizes
- Special Hole Location
- Carbon Steel, Alloy, Stainless, Aluminum
- Heat Treatment
- Special Finishes

We offer free engineering assistance and samples!



Get quote »



Angic Global Solutions
<https://www.AngicGlobal.com> Sales@AngicGlobal.com

1-888-872-0690



The Right Holding Force

Detent Clevis Pins

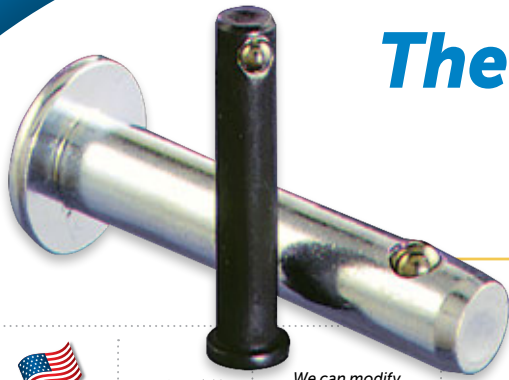

MADE TO ORDER

We can modify ball compression force to create the holding force you need!

Ball detent depresses and springs up to hold clevis pin in place. Used for assembly speed or hard-to-cotter applications. This fastener lowers labor costs and offers quick release features for flush-mount applications.

Made to order, detent clevis pins are based on standard clevis pin head and shank dimensions. Ends are pointed for easy insertion. Pins are typically zinc plated carbon steel and the ball detent is stainless type 302. Pin is also available in stainless, alloy and other materials.

Ball compression force can be adjusted at time of manufacture to meet force required to insert and remove. All parts are subject to rigid quality control procedures for long life service.

Detent Clevis Pin Specs								
Basic Shank Diameter	Shank Diameter A	Head Diameter B	Head Height C	Head Chamfer D	Ball Height Approx.	Ball Size	Ball Force at Flush (lbs.)	
3/16	.181 - .186	.310	.060	.04 x 22°	0.028	3/32	3	
1/4	.243 - .248	.370	.090	.055 x 22°	0.038	1/8	6	
5/16	.306 - .311	.430	.090	.065 x 22°	0.047	5/32	8	
3/8	.368 - .373	.500	.120	.07 x 22°	0.056	3/16	10	
7/16	.431 - .436	.560	.150	.07 x 22°	0.066	7/32	10	
1/2	.491 - .496	.620	.150	.09 x 22°	0.075	1/4	10	
5/8	.616 - .621	.810	.200	.115 x 22°	0.075	1/4	10	
3/4	.741 - .746	.930	.250	.115 x 22°	0.094	5/16	23	
Metric Sizes	6 mm	5.95 - 6.00	10 mm	2 mm	1.4 mm x 22°	.95 mm	3.17 mm	26 Newton
	8 mm	7.91 - 8.00	14 mm	3 mm	1.65 mm x 22°	1.19 mm	3.97 mm	33 Newton
	10 mm	9.91 - 10.00	18 mm	4 mm	1.78 mm x 22°	1.43 mm	4.76 mm	48 Newton
	12 mm	11.90 - 12.00	20 mm	4 mm	2.29 mm x 22°	1.91 mm	6.35 mm	42 Newton

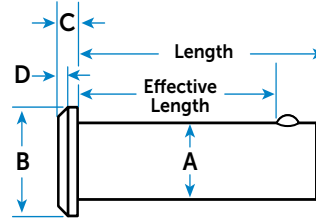

Lynch Pins

Made from low carbon steel, zinc plated and yellow chromate dipped, this pin is especially corrosion resistant. Ring is made from hard drawn MB spring wire. The "over center" ring loop attached to the head snaps down hard to hold the fastener in place. A special heavy duty ring is also available for extreme applications.



IMPORTED

Lynch Pins - Zinc With Yellow Chromate

STOCK CODE	APPROXIMATE NOMINAL DIMENSIONS						Approximate Weight/Pounds per 100 Pieces
	A Pin Diameter	B Shank Length	C Head Height	D Head Width	E Capture Length	F Wire Diameter	
HANG-1	3/16	1-1/2	1/2	5/16	1-1/16	.118	3.4
HANG-2	3/16	1-3/4	1/2	5/16	1-5/16	.138	4.4
HANG-4	1/4	1-3/4	1/2	9/32	1-5/16	.138	5.5
HANG-6	5/16	1-3/4	1/2	11/32	1-3/8	.138	7.0
HANG-7	3/8	1-3/4	15/32	25/64	1-1/2	.138	8.8
HANG-8	7/16	1-3/4	9/16	7/16	1-23/64	.138	10.8
HANG-8L	7/16	2-3/32	19/32	1/2	1-11/16	.138	12.0
HANG-8HD*	7/16	1-31/32	19/32	1/2	1-17/32	.197	14.2

* Zinc plated pin & black oxide ring.

Unless otherwise noted, all dimensions are for reference only.

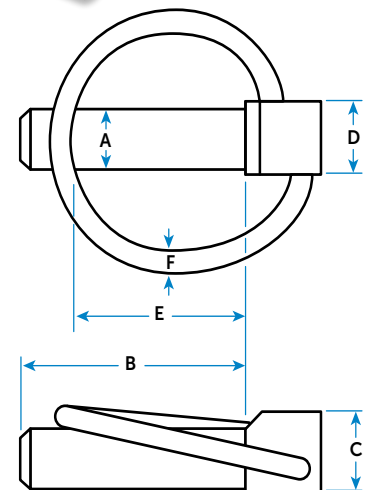

Wire Lock Pins



IMPORTED

Wire lock pins are like having a pin and cotter in one secure assembly. The wire loop is pulled over the pin end to lock it in place or remove it. This one-piece fastener eliminates cotter pin loss and fits most "quick release" applications.

Pin made of low carbon steel, wire loop made of hard drawn MB spring wire, zinc plated.

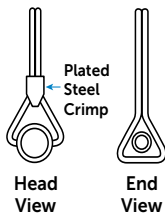
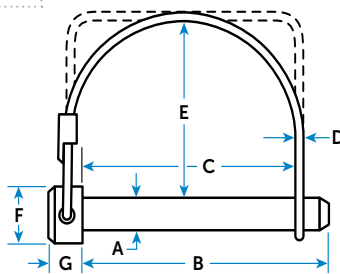

Wire Lock Pins - Zinc Plated

STOCK CODE	SIZE	A Pin Diameter	B Pin Length	C Effective Length	D Wire Diameter	E Loop Clearance	F Head Diameter	G Head Height	Wire Loop Shape	Approximate Weight/Pounds per 100 Pieces
WIRE-1RD	1/4 x 2	.243 - .248	2.000	1.750	.091	1.625	.562	.312	round	6.5
WIRE-2SQ	1/4 x 2-3/4	.243 - .248	2.750	2.500	.091	1.562	.625	.312	square	.8.18
WIRE-3SQ	5/16 x 2-3/4	.306 - .311	2.750	2.500	.091	1.750	.625	.312	square	10.6
WIRE-3RD	5/16 x 2-3/4	.306 - .311	2.750	2.500	.091	2.000	.625	.312	round	12.5
WIRE-5RD	5/16 x 2	.306 - .311	2.000	1.750	.091	1.625	.625	.250	round	10.0
WIRE-6RD	3/8 x 1-3/4	.368 - .373	1.750	1.500	.091	1.500	.625	.312	round	10.3
WIRE-7SQ	3/8 x 2-1/2	.368 - .373	2.500	2.250	.091	1.500	.625	.312	square	12.5

Unless otherwise noted, all dimensions are for reference only.

Keep your pins in place with Nylon Lanyards
See pages 34-35



Tab Lock Pins

Even easier to use than standard wire lock pins. Pull up on tab to remove, push down on wire loop to lock. Tab acts as a load ramp which guides wire loop to a locked position when installing. Pin made of low carbon steel, wire loop made of hard drawn MB spring wire, zinc plated.

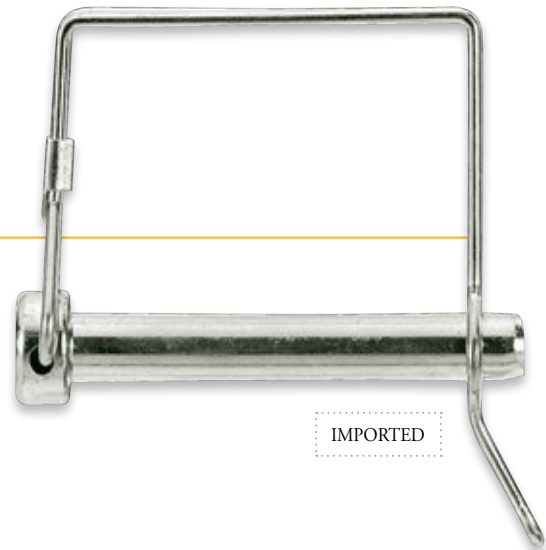

IMPORTED

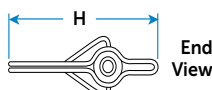
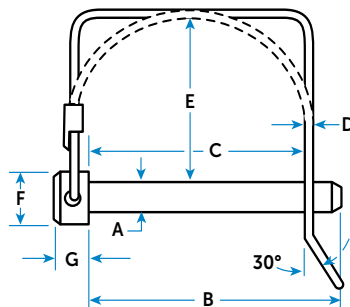

Tab Lock Pins - Zinc Plated

STOCK CODE	SIZE	A Pin Diameter	B Pin Length	C Effective Length	D Wire Diameter	E Loop Clearance	F Head Diameter	G Head Height	H Top of Wire to Tab End	Wire Loop Shape	Approximate Weight/Pounds per 100 Pieces
T-LOCK-1RD	1/4 x 2	.243 - .248	2.00	1.750	.091	1.625	.562	.312	2-3/4	round	6.8
T-LOCK-8SQ	3/8 x 2-3/4	.368 - .373	2.75	2.50	.091	1.500	.625	.312	2-3/4	square	13.8

Unless otherwise noted, all dimensions are for reference only.



Get quote >>



Angic Global Solutions

1-888-872-0690

<https://www.AngicGlobal.com> Sales@AngicGlobal.com

The Right Holding Force



Detent Pins

Ball detent depresses and springs up for "quick release" applications. Used as a convenient way to adjust or remove accessories on equipment. Now available in pull ring style and ball knob style.

Standard sizes are made from low carbon steel, zinc plated or 303 stainless. Rigid quality control procedures ensure a consistent fastener you can count on.

We can modify ball compression to create the holding force you need!

STAINLESS STOCKED

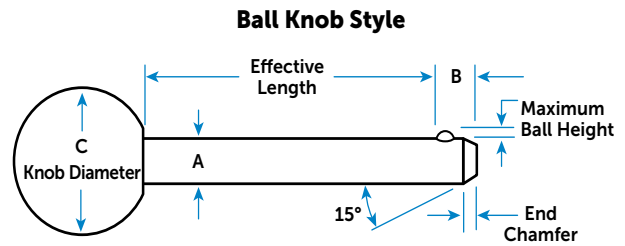
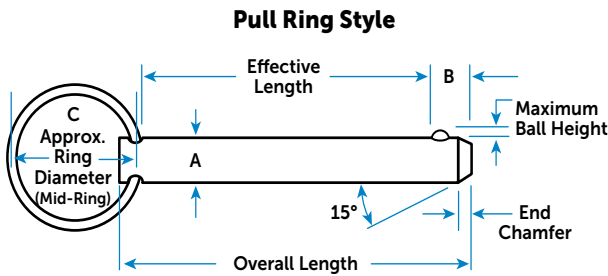

Detent Pin Specs (Standard)

Nominal Pin Diameter A	Diameter Tolerances Before Plating Cold Finished Rounds		Pull Ring Style C Pull Ring Diameter (inches)	Ball Knob Style C Knob Diameter (inches)	End Chamfer Length x 15 Deg. (inches)	B (inches) REF.	Ball Diameter	Maximum Ball Height Above Shank	Approximate Ball Compression Force, lbs.*	
	Carbon Steel	Stainless								
3/16	.1855 - .1875	.1865 - .1885	7/8	1	.078	.234	3/32	.028	3	
1/4	.2480 - .2500	.2490 - .2510	1	1	.094	.281	1/8	.038	6	
5/16	.3105 - .3125	.3110 - .3140	1	1-3/16	.125	.344	5/32	.047	8	
3/8	.3730 - .3750	.3735 - .3765	1	1-3/16	.141	.391	3/16	.056	10	
7/16	.4355 - .4375	.4360 - .4390	1	-	.156	.468	7/32	.066	10	
1/2	.4980 - .5000	.4980 - .5020	1-1/4	-	.172	.516	1/4	.075	10	
5/8	.6230 - .6250	.6230 - .6270	1-1/4	-	.188	.553 For 1/4 ball	615 For 5/16 ball	1/4	.075	10
3/4	.7480 - .7500	.7480 - .7520	1-1/2	-	.188	615 For 5/16 ball	678 For 3/8 ball	5/16	.094	23
6 mm	5.95 - 6.00	5.97 - 6.03	25.4 mm	-	2.4 mm	6.88 mm	3.18 mm	0.95 mm	26 Newton	
8 mm	7.95 - 8.00	7.96 - 8.04	25.4 mm	-	3.2 mm	8.45 mm	3.97 mm	1.19 mm	33 Newton	
10 mm	9.95 - 10.00	9.96 - 10.04	25.4 mm	-	3.6 mm	9.67 mm	4.76 mm	1.42 mm	48 Newton	
12 mm	11.95 - 12.00	11.95 - 12.05	31.75 mm	-	4.4 mm	12.84 mm	6.35 mm	1.91 mm	42 Newton	

Plating will typically add .0002" - .0005" to diameter.

* Ball Compression Force is the force required to compress ball flush to shank.

Detent Pins

STOCK SIZES (diameter x effective length)	Pull Ring Style Detent Pins				Ball Knob Style Detent Pins			
	STOCK CODE Steel, Zinc Plated	STOCK CODE Stainless Steel	Overall Length (Ref.)	Approximate Weight/Pounds per 100 Pieces	STOCK CODE Steel, Zinc Plated	STOCK CODE Stainless Steel	Approximate Weight/Pounds per 100 Pieces	
3/16	3/16 x 5/16				DRIK3-31	DRIK3-31SS	2.67	
	3/16 x 1/2				DRIK3-50	DRIK3-50SS	2.83	
	3/16 x 13/16	DRI-1	DRI-1SS	1.19	1.50	DRIK3-81	DRIK3-81SS	3.64
	3/16 x 1	DRI-2	DRI-2SS	1.37	1.65	DRIK3-100	DRIK3-100SS	3.79
	3/16 x 1-5/16	DRI-3	DRI-3SS	1.69	1.90	DRIK3-131	DRIK3-131SS	4.04
	3/16 x 1-1/2	DRI-4	DRI-4SS	1.87	2.04	DRIK3-150	DRIK3-150SS	4.18
	3/16 x 1-13/16	DRI-5	DRI-5SS	2.19	2.30			
	3/16 x 2	DRI-6	DRI-6SS	2.37	2.43			

Stock Detent Pins continued on page 15

Detent Pins

Continued from page 14

STOCK SIZES (diameter x effective length)	Pull Ring Style Detent Pins				Ball Knob Style Detent Pins			
	STOCK CODE Steel, Zinc Plated	STOCK CODE Stainless Steel	Overall Length (Ref.)	Approximate Weight/Pounds per 100 Pieces	STOCK CODE Steel, Zinc Plated	STOCK CODE Stainless Steel	Approximate Weight/Pounds per 100 Pieces	
1/4	1/4 x 1/4				DRIK4-25	DRIK4-25SS	3.08	
	1/4 x 1/2				DRIK4-50	DRIK4-50SS	3.42	
	1/4 x 3/4	DRI-11	DRI-11SS	1.17	2.20	DRIK4-75	DRIK4-75SS	4.34
	1/4 x 1	DRI-12	DRI-12SS	1.42	2.56	DRIK4-100	DRIK4-100SS	4.70
	1/4 x 1-1/4	DRI-13	DRI-13SS	1.67	2.90	DRIK4-125	DRIK4-125SS	5.04
	1/4 x 1-1/2	DRI-14	DRI-14SS	1.92	3.25	DRIK4-150	DRIK4-150SS	5.39
	1/4 x 1-3/4	DRI-15	DRI-15SS	2.17	3.60	DRIK4-175	DRIK4-175SS	5.74
	1/4 x 2	DRI-16	DRI-16SS	2.42	3.95	DRIK4-200	DRIK4-200SS	6.09
	1/4 x 2-1/4	DRI-17	DRI-17SS	2.67	4.30	DRIK4-225	DRIK4-225SS	6.44
	1/4 x 2-1/2	DRI-18	DRI-18SS	2.92	4.64	DRIK4-250	DRIK4-250SS	6.78
5/16	1/4 x 2-3/4	DRI-19	DRI-19SS	3.17	5.00			
	1/4 x 3	DRI-20	DRI-20SS	3.42	5.34			
	5/16 x 1/8				DRIK5-13	DRIK5-13SS	5.06	
	5/16 x 1/4				DRIK5-25	DRIK5-25SS	5.34	
	5/16 x 1/2				DRIK5-50	DRIK5-50SS	5.88	
	5/16 x 5/8	DRI-29	DRI-29SS	1.16	3.30	DRIK5-63	DRIK5-63SS	6.15
	5/16 x 3/4	DRI-29A	DRI-29AS	1.28	3.59			
	5/16 x 1	DRI-30	DRI-30SS	1.53	4.14	DRIK5-100	DRIK5-100SS	7.78
	5/16 x 1-1/8	DRI-31	DRI-31SS	1.66	4.40	DRIK5-113	DRIK5-113SS	8.04
	5/16 x 1-1/2	DRI-32	DRI-32SS	2.03	5.22	DRIK5-150	DRIK5-150SS	8.86
3/8	5/16 x 1-5/8	DRI-33	DRI-33SS	2.16	5.50	DRIK5-163	DRIK5-163SS	9.14
	5/16 x 2	DRI-34	DRI-34SS	2.53	6.31	DRIK5-200	DRIK5-200SS	9.95
	5/16 x 2-1/8	DRI-35	DRI-35SS	2.66	6.50			
	5/16 x 2-1/2	DRI-36	DRI-36SS	3.03	7.40	DRIK5-250	DRIK5-250SS	11.04
	5/16 x 2-5/8				DRIK5-263	DRIK5-263SS	11.50	
	5/16 x 3	DRI-38	DRI-38SS	3.53	8.49			
	5/16 x 3-1/8	DRI-39	DRI-39SS	3.66	8.70			
	3/8 x 1/8				DRIK6-13	DRIK6-13SS	6.00	
	3/8 x 1/4				DRIK6-25	DRIK6-25SS	6.38	
	3/8 x 1/2				DRIK6-50	DRIK6-50SS	7.16	
7/16	3/8 x 5/8	DRI-49	DRI-49SS	1.25	4.14	DRIK6-63	DRIK6-63SS	7.78
	3/8 x 3/4	DRI-49A	DRI-49AS	1.38	4.53			
	3/8 x 1	DRI-50	DRI-50SS	1.63	5.31	DRIK6-100	DRIK6-100SS	8.95
	3/8 x 1-1/8	DRI-51	DRI-51SS	1.75	5.71	DRIK6-113	DRIK6-113SS	9.35
	3/8 x 1-1/2	DRI-52	DRI-52SS	2.13	6.88	DRIK6-150	DRIK6-150SS	10.52
	3/8 x 1-5/8	DRI-53	DRI-53SS	2.25	7.29	DRIK6-163	DRIK6-163SS	10.93
	3/8 x 2	DRI-54	DRI-54SS	2.63	8.44	DRIK6-200	DRIK6-200SS	12.08
	3/8 x 2-1/8	DRI-55	DRI-55SS	2.75	8.84	DRIK6-213	DRIK6-213SS	12.48
	3/8 x 2-1/2	DRI-56	DRI-56SS	3.13	10.01	DRIK6-250	DRIK6-250SS	13.65
	3/8 x 2-5/8	DRI-57	DRI-57SS	3.25	10.40	DRIK6-263	DRIK6-263SS	14.04
1/2	3/8 x 3	DRI-58	DRI-58SS	3.63	11.57			
	3/8 x 3-1/8	DRI-59	DRI-59SS	3.75	11.96			
	7/16 x 1	DRI-70	DRI-70SS	1.70	7.66			
	7/16 x 2	DRI-74	DRI-74SS	2.70	11.92			
	7/16 x 2-1/16	DRI-75	DRI-75SS	2.77	12.20			
	7/16 x 2-1/2	DRI-76	DRI-76SS	3.20	14.04			
	7/16 x 2-9/16	DRI-77	DRI-77SS	3.27	14.30			
	7/16 x 3	DRI-78	DRI-78SS	3.70	16.18			
	1/2 x 1	DRI-91	DRI-91SS	1.75	10.10			
	1/2 x 1-1/2	DRI-93	DRI-93SS	2.25	12.90			
1/2	1/2 x 2	DRI-95	DRI-95SS	2.75	15.70			
	1/2 x 2-1/2	DRI-97	DRI-97SS	3.25	18.50			
	1/2 x 3	DRI-99	DRI-99SS	3.75	21.30			



Get quote >>



Angic Global Solutions

1-888-872-0690

<https://www.AngicGlobal.com> Sales@AngicGlobal.com

More options now in stock!

Ball-Lock Pins



New!

Key-Locking Option

Ball-Lock Pins have a push button that initiates ball action and retraction. Ball-locking design combines secure fastening with "quick release" ease of removal. Double locking-ball design increases retention capabilities.

Our unique design features both a one-piece, cold-formed body and spindle for increased durability. Now stocked with a T-handle and Key-Lock option!

Stocked in heat-treated alloy steel for strength and durability. Standard finish is Zinc with Yellow Chromate. Other finishes available.

Ball-Lock Pin Features

- One-Piece Push Button/Spindle
- Zinc/Yellow Chromate Finish for Corrosion Resistance
- 440C Stainless Steel Balls Hardened to Rc 58-62

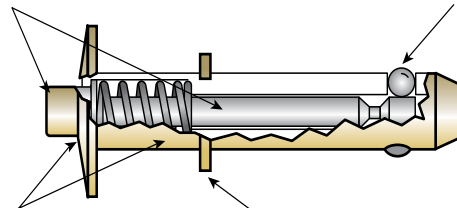

- One-Piece, Cold-Formed Head/Body - Alloy Steel Heat-treated
- Heavy-Duty Stop Collar



Our Exclusive Design Innovation

HIGH QUALITY COMMERCIAL EQUIVALENT!

Standard Ball-Lock Pin

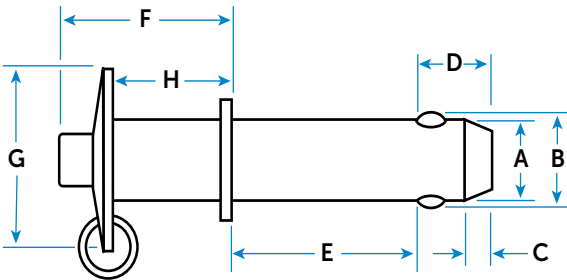

T-Handle Option

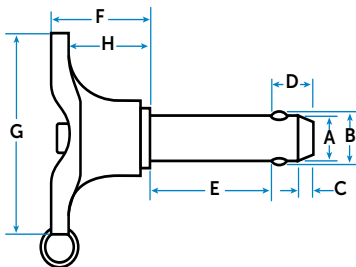

Key-Lock Option

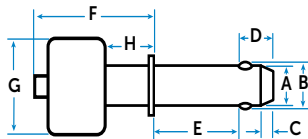

Ball-Lock Pin Specs

Shank Diameter A	Ball Height B	Chamfer Length x Deg C	End Length D	Effective Length E	Length F			G			Finger Space H			Approximate Double Shear/Pounds
					Standard	T-Handle	Key-Lock	Standard	T-Handle	Key-Lock	Standard	T-Handle	Key-Lock	
1/4 (.2455/.2485)	.284/.294	.093 x 22°	.312	as required	.870	inquire	1.73	.700	inquire	.83	.62	inquire	.60	8,200
5/16 (.308/.311)	.370/.380	.125 x 22°	.312	as required	.870	1.00	1.73	.800	2.13	.89	.62	.75	.60	12,800
3/8 (.3705/.3735)	.435/.445	.125 x 22°	.375	as required	.900	1.00	1.75	.860	2.13	1.00	.62	.75	.60	18,400
1/2 (.4955/.4985)	.589/.599	.125 x 22°	.437	as required	1.125	inquire	2.00	1.000	inquire	1.08	.79	inquire	.77	32,800

Unless otherwise noted, all dimensions are for reference only.

Ball-Lock Pins continued on page 17



Ball-Lock Pins

Continued from page 16

STOCK CODE	STOCK SIZES diameter (A) x effective length (E)	VERSION	F	G	H	Approximate Weight/Pounds per 100 Pieces
PL4-500	1/4 x 1/2	Standard	0.87	0.70	0.62	2.84
PLK4-500	1/4 x 1/2	Key-Locking	1.73	0.83	0.60	14.84
PL4-750	1/4 x 3/4	Standard	0.87	0.70	0.62	3.19
PLK4-750	1/4 x 3/4	Key-Locking	1.73	0.83	0.60	15.19
PL4-1000	1/4 x 1	Standard	0.87	0.70	0.62	3.54
PLK4-1000	1/4 x 1	Key-Locking	1.73	0.83	0.60	15.54
PL4-1250	1/4 x 1-1/4	Standard	0.87	0.70	0.62	3.89
PLK4-1250	1/4 x 1-1/4	Key-Locking	1.73	0.83	0.60	15.89
PL4-1500	1/4 x 1-1/2	Standard	0.87	0.70	0.62	4.24
PLK4-1500	1/4 x 1-1/2	Key-Locking	1.73	0.83	0.60	16.24
PL5-1000	5/16 x 1	Standard	0.90	0.80	0.62	5.37
PLK5-1000	5/16 x 1	Key-Locking	1.73	0.89	0.60	19.25
PLT5-1000	5/16 x 1	T-Handle	1.00	2.13	0.75	11.57
PL5-1250	5/16 x 1-1/4	Standard	0.90	0.80	0.62	5.90
PLK5-1250	5/16 x 1-1/4	Key-Locking	1.73	0.89	0.60	19.78
PLT5-1250	5/16 x 1-1/4	T-Handle	1.00	2.13	0.75	12.10
PL5-1500	5/16 x 1-1/2	Standard	0.9	0.80	0.62	6.42
PLK5-1500	5/16 x 1-1/2	Key-Locking	1.73	0.89	0.60	20.30
PLT5-1500	5/16 x 1-1/2	T-Handle	1.00	2.13	0.75	12.62
PL5-1750	5/16 x 1-3/4	Standard	0.90	0.80	0.62	6.94
PLK5-1750	5/16 x 1-3/4	Key-Locking	1.73	0.89	0.60	20.82
PLT5-1750	5/16 x 1-3/4	T-Handle	1.00	2.13	0.75	13.14
PL5-2000	5/16 x 2	Standard	0.90	0.80	0.62	7.44
PLK5-2000	5/16 x 2	Key-Locking	1.73	0.89	0.60	21.32
PLT5-2000	5/16 x 2	T-Handle	1.00	2.13	0.75	13.64
PL6-1000	3/8 x 1	Standard	0.90	0.86	0.62	7.70
PLK6-1000	3/8 x 1	Key-Locking	1.75	1.00	0.60	25.76
PLT6-1000	3/8 x 1	T-Handle	1.00	2.13	0.75	13.90
PL6-1250	3/8 x 1-1/4	Standard	0.90	0.86	0.62	8.48
PLK6-1250	3/8 x 1-1/4	Key-Locking	1.75	1.00	0.60	26.54
PLT6-1250	3/8 x 1-1/4	T-Handle	1.00	2.13	0.75	14.68
PL6-1500	3/8 x 1-1/2	Standard	0.90	0.86	0.62	9.25
PLK6-1500	3/8 x 1-1/2	Key-Locking	1.75	1.00	0.60	27.31
PLT6-1500	3/8 x 1-1/2	T-Handle	1.00	2.13	0.75	15.45
PL6-1750	3/8 x 1-3/4	Standard	0.90	0.86	0.62	10.03
PLK6-1750	3/8 x 1-3/4	Key-Locking	1.75	1.00	0.60	28.09
PLT6-1750	3/8 x 1-3/4	T-Handle	1.00	2.13	0.75	16.23
PL6-2000	3/8 x 2	Standard	0.90	0.86	0.62	10.80
PLK6-2000	3/8 x 2	Key-Locking	1.75	1.00	0.60	28.86
PLT6-2000	3/8 x 2	T-Handle	1.00	2.13	0.75	17.00
PL6-2250	3/8 x 2-1/4	Standard	0.90	0.86	0.62	11.58
PLK6-2250	3/8 x 2-1/4	Key-Locking	1.75	1.00	0.60	29.64
PLT6-2250	3/8 x 2-1/4	T-Handle	1.00	2.13	0.75	17.78
PL6-2500	3/8 x 2-1/2	Standard	0.90	0.86	0.62	12.35
PLK6-2500	3/8 x 2-1/2	Key-Locking	1.75	1.00	0.60	30.41
PLT6-2500	3/8 x 2-1/2	T-Handle	1.00	2.13	0.75	18.55
PL8-1000	1/2 x 1	Standard	1.16	1.00	0.79	13.65
PLK8-1000	1/2 x 1	Key-Locking	2.00	1.08	0.77	35.61
PL8-1500	1/2 x 1-1/2	Standard	1.16	1.00	0.79	16.45
PLK8-1500	1/2 x 1-1/2	Key-Locking	2.00	1.08	0.77	38.41
PL8-1750	1/2 x 1-3/4	Standard	1.16	1.00	0.79	17.85
PLK8-1750	1/2 x 1-3/4	Key-Locking	2.00	1.08	0.77	39.81
PL8-2000	1/2 x 2	Standard	1.16	1.00	0.79	19.25
PLK8-2000	1/2 x 2	Key-Locking	2.00	1.08	0.77	41.21
PL8-2500	1/2 x 2-1/2	Standard	1.16	1.00	0.79	22.05
PLK8-2500	1/2 x 2-1/2	Key-Locking	2.00	1.08	0.77	44.01
PL8-3000	1/2 x 3	Standard	1.16	1.00	0.79	24.85
PLK8-3000	1/2 x 3	Key-Locking	2.00	1.08	0.77	46.81
PL8-3500	1/2 x 3-1/2	Standard	1.16	1.00	0.79	27.65
PLK8-3500	1/2 x 3-1/2	Key-Locking	2.00	1.08	0.77	49.61

Ball-Lock pins are now available with added security options!

Secondary Lock

Push button can only be depressed (thus disengaging balls) if the spring-loaded "security catch" is depressed.



Dirt Cap

Installed into the "hollow" end of the pin, keeping dirt out and balls functioning properly. Great for applications where pin frequently contacts soils or other sources of extreme dirt contamination.



Customize a Ball-Lock Pin to your exact needs

- Additional locking balls
- Special finishes
- Special head shape



Get quote >>



Angic Global Solutions

<https://www.AngicGlobal.com> Sales@AngicGlobal.com

1-888-872-0690

New!

Auto-Lock Safety Pull Pin

U.S. Patent No. 8,821,061

Standard Style



PATENTED

Our Exclusive Innovation

PRECISION MADE in the U.S.A.

MADE TO ORDER

Our NEW Auto-Lock Safety Pull Pin features a retractable tip that locks into an extended (forward) position automatically. Conventional spring-loaded pull pins do not lock forward, allowing unintended retraction and disengagement due to vibration, movement and irregular mating holes. Our new forward-locked design means that the tip remains in an extended, locked position until manually disengaged by pulling the ring.

Standard material is low carbon steel body with hardened Grade 8 tip, zinc plated.

Push-Button Style

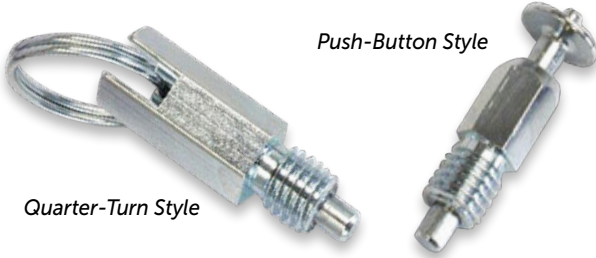

Quarter-Turn Style

AUTO-LOCK SAFETY PULL PIN ADVANTAGES

- Retractable tip locks into an extended (forward) position automatically
- Will not disengage until ring is pulled



Auto-Lock Safety Pull Pin Demo

Quarter-Turn style locks in both forward and retracted position

Push-Button style also locks in retracted position

Available with multiple locking positions

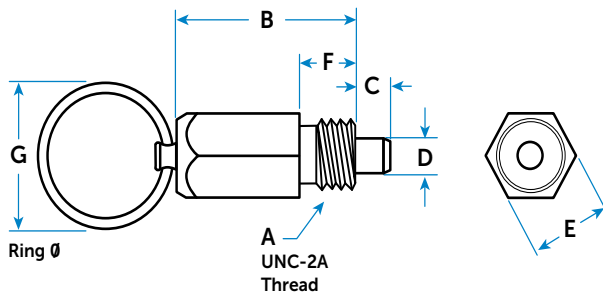

Watch the demonstration video at www.pivotpins.com/video-gallery.html

Auto-Lock Safety Pull Pin - Zinc Plated

STOCK CODE	Thread		C	D	E	F	G	Nominal Pin Diameter A	Approximate Weight/Pounds per 100 Pieces
	A	B							
ALP-500	1/2-13	1.397	.280	.250	.625	.440	1	1/2	9.21

Unless otherwise noted, all dimensions are for reference only.

Pull Pins

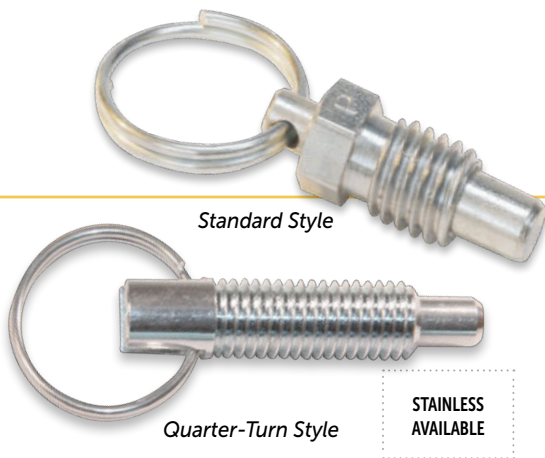

Body is threaded into application, with ring on outside surface. Pull ring to retract spring-loaded tip and allow adjustments. Release ring to lock tip into desired hole location. Chamfered tip allows for easy alignment. Ideal for adjustable tubing, tooling, latches, fixtures, gates and much more. Quarter-Turn style locks back in retracted position.

Stock sizes are low carbon steel, zinc plated. Special sizes and materials are available.

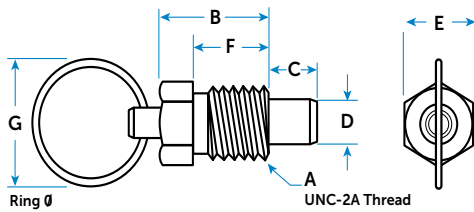

Pull Pin Specs - Standard Style

Nominal Thread Diameter	Approximate Pull Force, lbs.		A	B	C	D	E	F	G
	Initial	Final							
1/4	.50	2.00	1/4-20	.44	.19	.16	.25	.31	.875
3/8	.75	3.00	3/8-16	.63	.28	.25	.38	.44	.875
1/2	1.00	4.00	1/2-13	.81	.38	.31	.50	.56	1.00
5/8	1.25	5.00	5/8-11	1.00	.44	.38	.62	.69	1.00

Unless otherwise noted, all dimensions are for reference only.

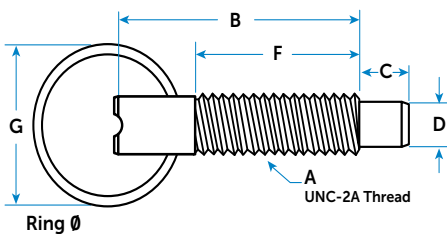

Pull Pin Specs - Quarter-Turn Style

Nominal Thread Diameter	Approximate Pull Force, lbs.		A	B	C	D	F	G
	Initial	Final						
1/4	1.00	3.00	1/4-20	1.14	.27	.15	.80	.875
3/8	2.00	4.50	3/8-16	1.68	.39	.23	1.20	1.00
1/2	2.50	5.50	1/2-13	2.00	.52	.31	1.40	1.25

Unless otherwise noted, all dimensions are for reference only.

Pull Pin Demo

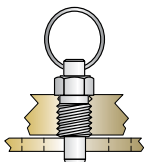

Install Pull Pin into pre-tapped hole in material.



Pull ring to retract tip and allow for adjustments. Release ring, and plunger locks into desired hole position.

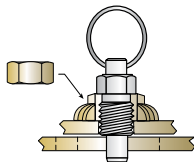

For lighter gauge materials, a nut may be welded to outside of material. The Pull Pin then threads into the nut.

Pull Pins - Zinc Plated

STOCK CODE Standard Style	STOCK CODE Quarter-Turn Style	Nominal Thread Diameter	Standard Style Approximate Weight/Pounds per 100 Pieces	Quarter-Turn Style Approximate Weight/Pounds per 100 Pieces
PULL-250X*	PULLQT-250X	1/4	.98	1.56
PULL-375X	PULLQT-375X	3/8	2.00	4.24
PULL-500X	PULLQT-500X	1/2	4.50	8.92
PULL-625X		5/8	8.50	

** PULL-250X plunger is not hardened.*



CHOOSE A PULL PIN MADE TO YOUR EXACT SPECIFICATIONS!

- Special Size
- Different Material/Finish
- Special Pull Force
- Knob Style
- More!



Ball Plungers/ Spring-Loaded Devices



Non-threaded design push-fits into hole. Spring-loaded ball forms bearing surface which retracts and then snaps into opposing hole or groove. Use for locating or positioning in drawers, doors, dies and other fixtures. Specials available in a variety of sizes, materials and finishes. Stock sizes are low carbon steel, black oxide finish with a 300-series stainless steel ball.

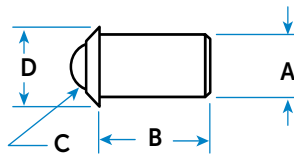

Ball Plunger/Spring-Loaded Device Demo

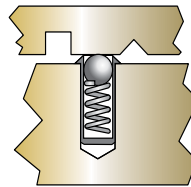

Install Ball Plunger into push-fit hole in material. Spring-loaded ball automatically depresses to allow adjustments.

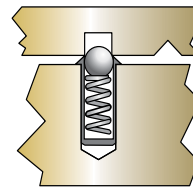

Spring-loaded ball then snaps back into the desired hole, groove or indentation.

Ball Plungers/Spring-Loaded Devices - Black Oxide Finish

STOCK CODE	STOCK SIZES	Pull Force, lbs.		A	B	C	D	Approximate Weight/Pounds per 100 Pieces
		Initial	Final					
BP4-471	1/4	3	7	.250	.471	.187	.312	.56
BP6-786	3/8	5	14	.375	.786	.313	.500	1.69

Unless otherwise noted, all dimensions are for reference only.

DESIGN A SPRING-LOADED DEVICE MADE TO YOUR EXACT SPECIFICATIONS!

We offer free engineering assistance and samples.

- Special Size
- Special Body Shape
- Different Material/Finish
- Higher/Lower Compression Force
- More!



Add a Wire Rope Lanyard to tether pin/cotter.

See pages 24-25.



Ring Pins



Check out our patented Bow-Tie Locking Cotters™ on page 36-37.

Convenient, removable pin designed with a cotter hole for a secure application. Used typically with a hair pin cotter or Bow-Tie Cotter, Ring Pins afford quick and secure fastening. Available with or without a stop collar in various styles and sizes.

Standard material is low carbon steel, zinc plated. Available in higher carbon steel which can be heat-treated, or corrosion-resistant stainless steel.

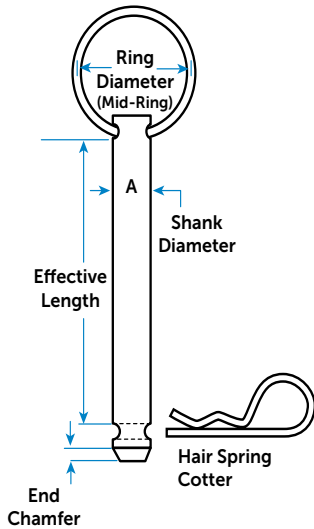

Ring Pin Specs

Nominal Pin Diameter A	Diameter Tolerances Before Plating Cold Finished Rounds		Ring Diameter (inches)	End Chamfer Length (inches)	Pivot Point Standard Hole Diameter	Recommended Bow-Tie Cotter™* (pages 36-37)
	Carbon Steel	Stainless				
3/16	.1855 - .1875	.1865 - .1885	7/8	.078 x 15°	3/32	Bow-54
1/4	.2480 - .2500	.2490 - .2510	1	.094 x 15°	3/32	Bow-54 Bow-72
5/16	.3105 - .3125	.3110 - .3140	1	.125 x 15°	1/8	Bow-72 Bow-91
3/8	.3730 - .3750	.3735 - .3765	1	.141 x 15°	9/64	Bow-91
7/16	.4355 - .4375	.4360 - .4390	1	.156 x 15°	5/32	Bow-91-8 Bow-120
1/2	.4980 - .5000	.4980 - .5020	1-1/4	.172 x 15°	5/32	Bow-91-8 Bow-120
5/8	.6230 - .6250	.6230 - .6270	1-1/4	.188 x 15°	5/32	Bow-120-10 Bow-148-10
3/4	.7480 - .7500	.7480 - .7520	1-1/2	.188 x 25°	3/16	Bow-120-12 Bow-148-12

Plating will typically add .0002" - .0005" to diameter.

*NOTE: See page 36 for recommended hole sizes for use with Bow-Tie Cotter™ Pins

Unless otherwise noted, all dimensions are for reference only.

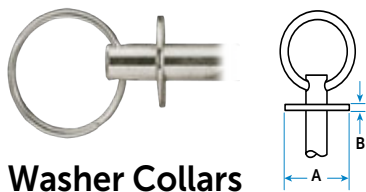

Washer Collars

Standard zinc plated flat washers stamped firmly into a groove for a permanent stop. Assembly is completely plated.

Pin Diameter	Washer Dimensions	
	O.D. A	Thickness B
3/16	7/16	.047
1/4	9/16	.047
5/16	3/4	.062
3/8	7/8	.078
7/16	1	.078
1/2	1-1/4	.078
5/8	1-1/2	.109
3/4	1-1/2	.109

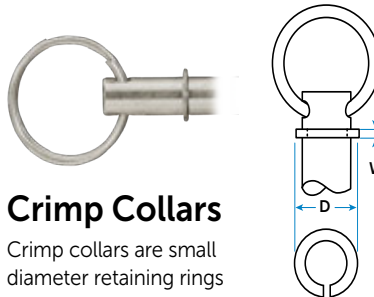

Crimp Collars

Crimp collars are small diameter retaining rings made of ductile 1010 carbon steel. Pressed into a groove, the collar is generally free to rotate, yet strong against end thrust. Assembly is completely plated.

Pin Diameter	Collar Dimensions	
	O.D. Installed D	Thickness W
3/16	.250	.031
1/4	.312	.031
5/16	.406	.039
3/8	.500	.047
7/16	.594	.055
1/2	.688	.063
5/8	.859	.078
3/4	1.031	.094

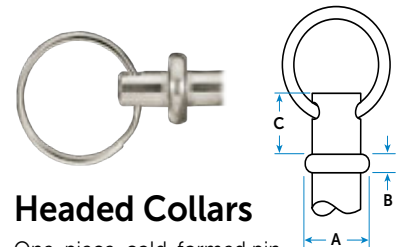

Headed Collars

One-piece, cold-formed pin and collar for the highest durability.

Pin Diameter	O.D. A	Collar Thickness B	Length C
3/16	5/16	.060	.410
1/4	7/16	.090	.410
5/16	1/2	.090	.750
3/8	5/8	.100	.750
7/16	3/4	.125	.750
1/2	7/8	.125	.750

Unless otherwise noted, all dimensions are for reference only.



Get quote »



Angic Global Solutions

1-888-872-0690

<https://www.AngicGlobal.com> Sales@AngicGlobal.com

Versatile & Low-Cost

Bent Arm Pins

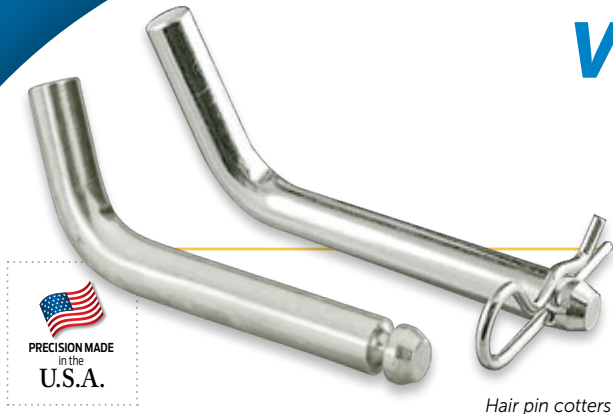

Hair pin cotters sold separately. See page 40.

Pin with bent handle provides one-piece configuration. Here's a low cost pin available for applications requiring frequent removals. Made as a standard with a hole, in low carbon steel, zinc plated.

Also available with grooves, higher-strength material or heat-treated.

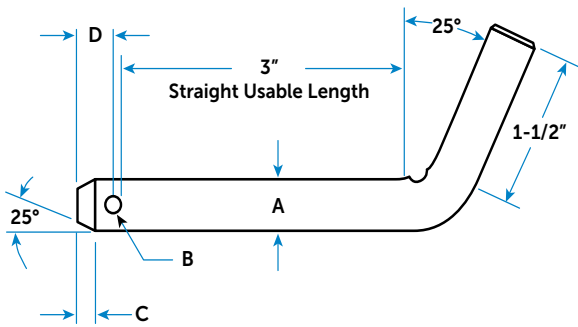

Bent Arm Pins - Zinc Plated

STOCK CODE	STOCK SIZES	STYLE	Pin Diameter A	Hole Diameter B	Chamfer Length C	Hole O.C. from End D	Use Cotter Number	Approximate Weight/Pounds per 100 Pieces
BENT8-300	1/2 x 3	Hole	.500	5/32	.187	.375	HAIR-8	32
BENT10-300	5/8 x 3	Hole	.625	3/16	.187	.437	HAIR-10	50

Unless otherwise noted, all dimensions are for reference only.

Contact us for a quote on other materials and sizes, including metric.



Headless Pins

Made to order with holes or grooves, this versatile fastener can be made from various materials to fit your application. Usually made in low carbon steel. Higher strength carbon or alloy steel and corrosion resistant stainless are available.

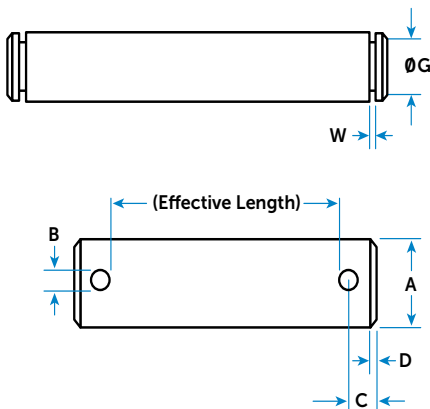

Headless Pin Standard Specs

Shank Diameter A	Diameter Tolerances Before Plating Cold Finished Rounds		With Grooves for Standard E-Rings		With Holes		
	Carbon Steel	Stainless	Groove Width W	Groove Diameter G	Hole Diameter B	Hole Location O.C. to End of Pin C	End Chamfer Length x Deg. D
3/16	.1855 - .1875	.1865 - .1885	.029	.147	3/32	.094	.016 x 45°
1/4	.2480 - .2500	.2490 - .2510	.029	.210	3/32	.094	.016 x 45°
5/16	.3105 - .3125	.3110 - .3140	.029	.250	1/8	.125	.016 x 45°
3/8	.3730 - .3750	.3735 - .3765	.039	.303	9/64	.156	.031 x 45°
7/16	.4355 - .4375	.4360 - .4390	.039	.343	5/32	.156	.031 x 45°
1/2	.4980 - .5000	.4980 - .5020	.046	.396	5/32	.156	.031 x 45°
5/8	.6230 - .6250	.6230 - .6270	.046	.485	5/32	.156	.031 x 45°
3/4	.7480 - .7500	.7480 - .7520	.056	.625	5/32	.156	.047 x 45°
Metric Sizes	6 mm	5.95 - 6.00	5.97 - 6.03	As Required	As Required	As Required	As Required
	8 mm	7.95 - 8.00	7.96 - 8.04	As Required	As Required	As Required	As Required
	10 mm	9.95 - 10.00	9.96 - 10.04	As Required	As Required	As Required	As Required
	12 mm	11.95 - 12.00	11.95 - 12.05	As Required	As Required	As Required	As Required

Plating will typically add .0002" - .0005" to diameter.

Unless otherwise noted, all dimensions are for reference only.

New!

Push-Pull Control Cables

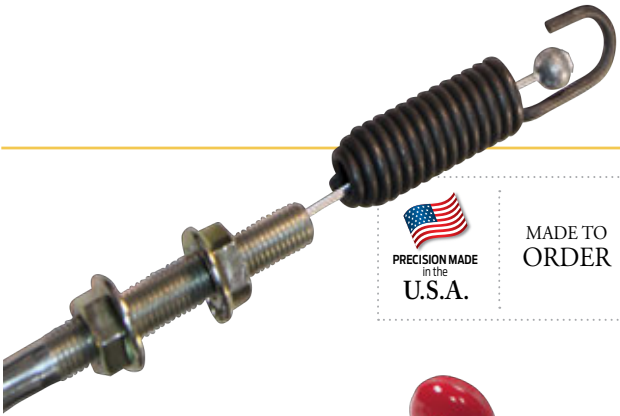

MADE TO ORDER

Push-Pull Control Cables are used to transmit mechanical motion. Typically, a cable core moves forward(push) and backward (pull) inside of a protective conduit or sheath to cause a desired movement or actuation at the end of the cable core. The travel or stroke length is designed to suit the application.

Some common applications include:

- Throttle control
- Braking control
- Actuator cable
- Latching/unlatching cable
- Shifting control

Various conduit constructions are available, with "Bowden" conduit being the most common. See below for more information about some of the options available.

A multitude of fittings are available, including clevises, threaded ends, eyelets, ball and swage fittings, bulkhead fittings and more.

Made per your specifications or drawing(s) using either standard industry components or custom parts.



CONDUIT

Bare: no sheathing/liner; galvanized wire is very flexible with good crush resistance.

Sheathing: increases both abrasion resistance and corrosion resistance

Liner: reduces friction for the control assembly; high-density Polyethylene

Bicycle Conduit: ideal for smaller sized control cables.

Bowden Conduit: Bare

Sheathing: None
Liner: None

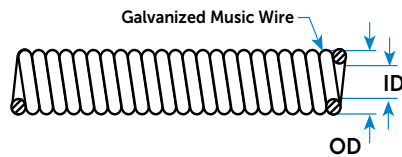

Bowden Conduit: Sheathed

Sheathing: Polyethylene
Liner: None

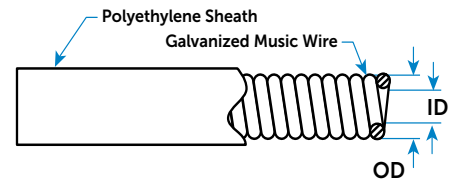

Bowden Conduit: Bare, Lined

Sheathing: None
Liner: Polyethylene

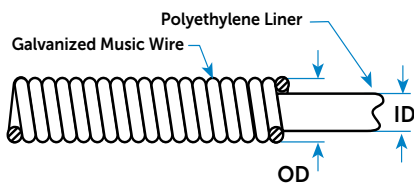

Bowden Conduit: Sheathed, Lined

Sheathing: Polyethylene
Liner: Polyethylene

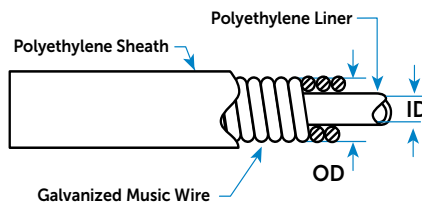

Bicycle Conduit

Sheathing: Nylon
Liner: Teflon

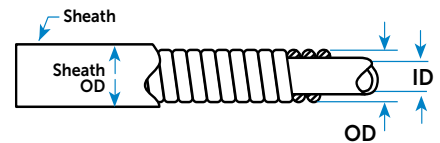

Get quote »



Angic Global Solutions

1-888-872-0690

<https://www.AngicGlobal.com> Sales@AngicGlobal.com

Low Cost & Fast Delivery

Wire Rope Lanyards

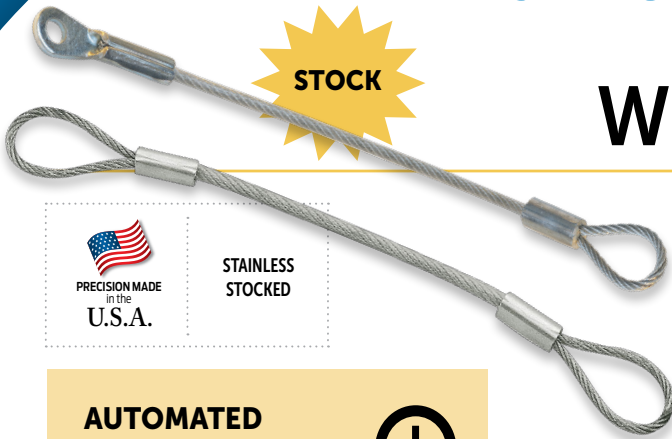

**AUTOMATED
MANUFACTURING
PROVIDES:**



- High quality
- Low prices
- Fast delivery
- Competitive with imports

Pivot Point manufactures high-quality Wire Rope Lanyard assemblies, which are typically used as tethers for pins and other components to prevent loss, as well as for door restraint cables and other uses.

Stock lanyards are available in 3/64" or 1/16" diameter wire rope. Choose from galvanized or stainless cable, coated or uncoated, 6" or 12" length and Type 1, 2 or 3 configuration.

Steel Lanyard Specs					
Cable Diameter	Diameter with Coating	Standard Loop Size (inches)	Standard Eyelet Diameter (inches)	Minimum Breaking Strength (lbs.) (Cable Only)	Approx. Breaking Strength (lbs.) (Lanyard Assemblies)
3/64	1/16	3/4	.190	270	215
1/16	3/32	7/8	.190	480	385
3/32	1/8	1 or 1-1/4 (min.)*	.250	920	735
1/8	3/16	1-1/2 (min.)	.316	1700	1350

Unless otherwise noted, all dimensions are for reference only.
* 1" min. for stripped loops, 1-1/4" min. for unstripped loops.

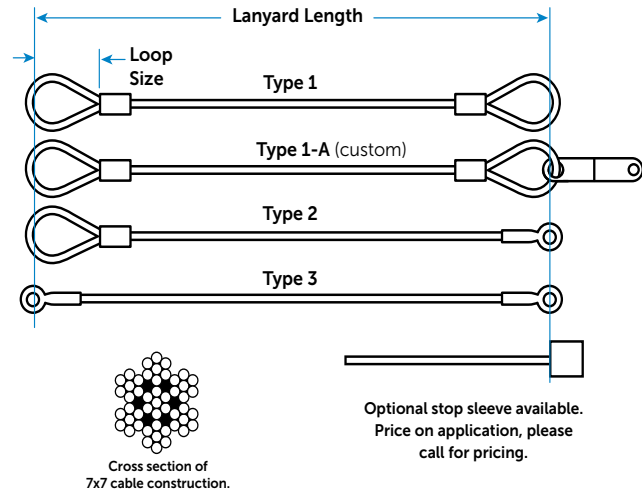

Wire Rope Lanyards

STOCK CODE	Cable Diameter (inches)	Length (inches)	Type	Cable Material	Coating (inches)	Approximate Weight/Pounds per 100 Pieces
L47B-600-1	3/64	6	1	Galvanized	Bare cable	0.42
L47N-600-1	3/64	6	1	Galvanized	Nylon to 1/16	0.51
L47P-600-1	3/64	6	1	Galvanized	PVC to 1/16	0.50
L47B-600S-1	3/64	6	1	Stainless	Bare cable	0.42
L47N-600S-1	3/64	6	1	Stainless	Nylon to 1/16	0.51
L47P-600S-1	3/64	6	1	Stainless	PVC to 1/16	0.50
L47B-600-2	3/64	6	2	Galvanized	Bare cable	0.59
L47N-600-2	3/64	6	2	Galvanized	Nylon to 1/16	0.66
L47P-600-2	3/64	6	2	Galvanized	PVC to 1/16	0.65
L47B-600S-2	3/64	6	2	Stainless	Bare cable	0.59
L47N-600S-2	3/64	6	2	Stainless	Nylon to 1/16	0.66
L47P-600S-2	3/64	6	2	Stainless	PVC to 1/16	0.65
L47B-600-3	3/64	6	3	Galvanized	Bare cable	0.75
L47N-600-3	3/64	6	3	Galvanized	Nylon to 1/16	0.81
L47P-600-3	3/64	6	3	Galvanized	PVC to 1/16	0.80
L47B-600S-3	3/64	6	3	Stainless	Bare cable	0.75
L47N-600S-3	3/64	6	3	Stainless	Nylon to 1/16	0.81

Unless otherwise noted, all dimensions are for reference only.

Wire Rope Lanyards continued on page 27

Wire Rope Lanyards

Continued from page 26

STOCK CODE	Cable Diameter (inches)	Length (inches)	Type	Cable Material	Coating (inches)	Approximate Weight/Pounds per 100 Pieces
L47P-600S-3	3/64	6	3	Stainless	PVC to 1/16	0.80
L62B-600-1	1/16	6	1	Galvanized	Bare cable	0.75
L62N-600-1	1/16	6	1	Galvanized	Nylon to 3/32	1.10
L62P-600-1	1/16	6	1	Galvanized	PVC to 3/32	0.95
L62B-600S-1	1/16	6	1	Stainless	Bare cable	0.75
L62N-600S-1	1/16	6	1	Stainless	Nylon to 3/32	1.10
L62P-600S-1	1/16	6	1	Stainless	PVC to 3/32	0.95
L62B-600-2	1/16	6	2	Galvanized	Bare cable	1.20
L62N-600-2	1/16	6	2	Galvanized	Nylon to 3/32	1.38
L62P-600-2	1/16	6	2	Galvanized	PVC to 3/32	1.26
L62B-600S-2	1/16	6	2	Stainless	Bare cable	1.20
L62N-600S-2	1/16	6	2	Stainless	Nylon to 3/32	1.38
L62P-600S-2	1/16	6	2	Stainless	PVC to 3/32	1.26
L62B-600-3	1/16	6	3	Galvanized	Bare cable	1.48
L62N-600-3	1/16	6	3	Galvanized	Nylon to 3/32	1.87
L62P-600-3	1/16	6	3	Galvanized	PVC to 3/32	1.59
L62B-600S-3	1/16	6	3	Stainless	Bare cable	1.48
L62N-600S-3	1/16	6	3	Stainless	Nylon to 3/32	1.87
L62P-600S-3	1/16	6	3	Stainless	PVC to 3/32	1.59
L47B-1200-1	3/64	12	1	Galvanized	Bare cable	0.63
L47N-1200-1	3/64	12	1	Galvanized	Nylon to 1/16	0.77
L47P-1200-1	3/64	12	1	Galvanized	PVC to 1/16	0.77
L47B-1200S-1	3/64	12	1	Stainless	Bare cable	0.63
L47N-1200S-1	3/64	12	1	Stainless	Nylon to 1/16	0.77
L47P-1200S-1	3/64	12	1	Stainless	PVC to 1/16	0.77
L47B-1200-2	3/64	12	2	Galvanized	Bare cable	0.80
L47N-1200-2	3/64	12	2	Galvanized	Nylon to 1/16	0.92
L47P-1200-2	3/64	12	2	Galvanized	PVC to 1/16	0.92
L47B-1200S-2	3/64	12	2	Stainless	Bare cable	0.80
L47N-1200S-2	3/64	12	2	Stainless	Nylon to 1/16	0.92
L47P-1200S-2	3/64	12	2	Stainless	PVC to 1/16	0.92
L47B-1200-3	3/64	12	3	Galvanized	Bare cable	0.96
L47N-1200-3	3/64	12	3	Galvanized	Nylon to 1/16	1.07
L47P-1200-3	3/64	12	3	Galvanized	PVC to 1/16	1.07
L47B-1200S-3	3/64	12	3	Stainless	Bare cable	0.96
L47N-1200S-3	3/64	12	3	Stainless	Nylon to 1/16	1.07
L47P-1200S-3	3/64	12	3	Stainless	PVC to 1/16	1.07
L62B-1200-1	1/16	12	1	Galvanized	Bare cable	1.15
L62N-1200-1	1/16	12	1	Galvanized	Nylon to 3/32	1.60
L62P-1200-1	1/16	12	1	Galvanized	PVC to 3/32	1.55
L62B-1200S-1	1/16	12	1	Stainless	Bare cable	1.15
L62N-1200S-1	1/16	12	1	Stainless	Nylon to 3/32	1.60
L62P-1200S-1	1/16	12	1	Stainless	PVC to 3/32	1.55
L62B-1200-2	1/16	12	2	Galvanized	Bare cable	1.60
L62N-1200-2	1/16	12	2	Galvanized	Nylon to 3/32	1.88
L62P-1200-2	1/16	12	2	Galvanized	PVC to 3/32	1.86
L62B-1200S-2	1/16	12	2	Stainless	Bare cable	1.60
L62N-1200S-2	1/16	12	2	Stainless	Nylon to 3/32	1.88
L62P-1200S-2	1/16	12	2	Stainless	PVC to 3/32	1.86
L62B-1200-3	1/16	12	3	Galvanized	Bare cable	1.88
L62N-1200-3	1/16	12	3	Galvanized	Nylon to 3/32	2.37
L62P-1200-3	1/16	12	3	Galvanized	PVC to 3/32	2.19
L62B-1200S-3	1/16	12	3	Stainless	Bare cable	1.88
L62N-1200S-3	1/16	12	3	Stainless	Nylon to 3/32	2.37
L62P-1200S-3	1/16	12	3	Stainless	PVC to 3/32	2.19



Get quote >>



Angic Global Solutions

1-888-872-0690

<https://www.AngicGlobal.com> Sales@AngicGlobal.com

We can design the exact

Custom Engineering

Shown is a very brief representation of our custom capabilities.

Can't find the exact fastener solution for your application? Contact us – we specialize in Custom-Engineered Solutions!

We'll work with you to develop the ideal fastener solution to suit your specific application, and we'll also provide preliminary prints and samples. Have a design in mind? Fax or email your sketch for a quote—we can often recommend cost saving alternatives.

We offer a diverse range of production capabilities, including:

- Screw machining
- Cold heading
- Drilling
- Ball detenting
- Machining
- Assembly
- and more!



Dual-Ball Detent Pin



Aluminum Pull Pin



Pull Pin with Knurled Knob



Pin and Lanyard Assembly



SLIC Pin™ with Special Head Geometry

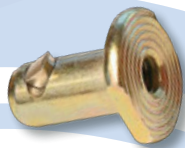

SLIC Pin™ with Tapped Head

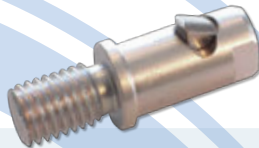

SLIC Pin™ with Threaded Stud End

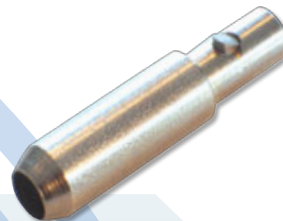

SLIC Pin™ with Barrel End



Stainless Machined Part

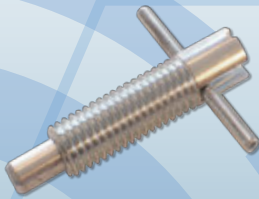

T-Handle Locking Pull Pin



Triple Ball Detent Pin



Multiple Ball Detent Ring Pin

act fastener you need!

Contact Us Today!



PINS > CABLES > SOLUTIONS

We love a challenge, so let us help you develop the perfect solution!



Short Grooved Pin



Bent Arm Pin with Ball Detent



Special Headless Pin with Multiple Grooves



Detent Pin with Cross Hole

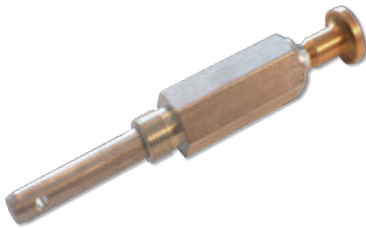

Special Locking Pin



Positive Lock Pin with Special Geometry

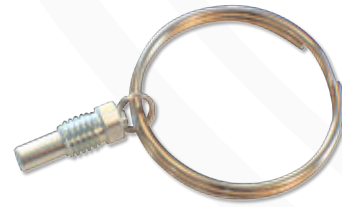

Small Pull Pin with Split Key Ring

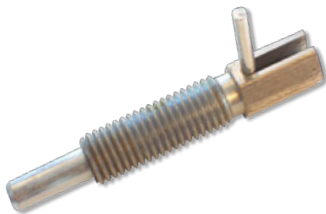

Retractable Locking Pull Pin

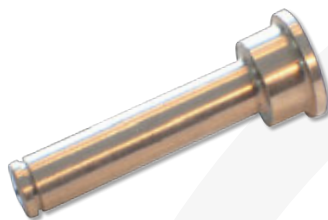

Grooved Stainless Steel Shoulder Pin



Special Machined Part

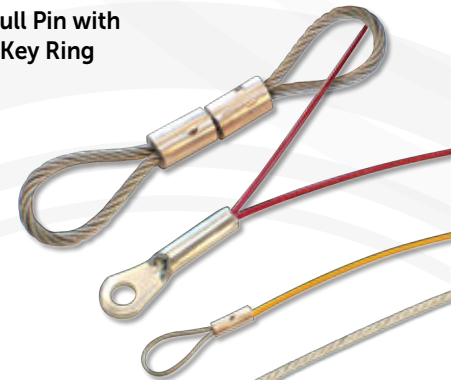

Various Steel Lanyards

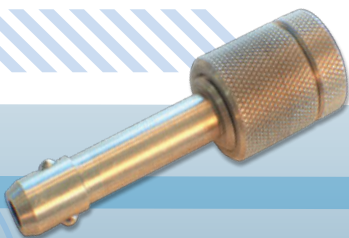

Key-Locking Detent Pin

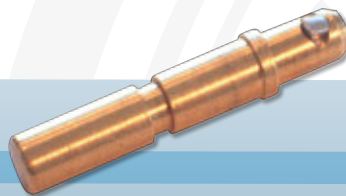

Brass SLIC Pin™ with Grooves



Special Spring Plunger



Get quote >>



Angic Global Solutions

1-888-872-0690

<https://www.AngicGlobal.com> Sales@AngicGlobal.com

CUSTOM

Per your Imagination!

Custom Wire Rope Lanyards



We specialize in custom wire rope lanyards to suit your specific application. Virtually endless configurations are available - limited only by your imagination!

Common end fittings for wire rope lanyards include: sleeves (for loops), stop sleeves, thimbles, stamped eyelets, mounting tabs, ball ends, ball shanks, threaded studs and more.

Typical wire rope coatings include PVC and Nylon. PVC coating is more popular because of its appearance, flexibility and low cost. Nylon offers more durability and abrasion resistance. Coatings are available in many colors.

Contact us today to help you create the perfect wire rope lanyard for your application.



CUSTOM DESIGN CHECKLIST



- Cable Diameter
- Cable Length
- End Fittings
- Coating

DIY Assemblies

End Fittings



Various end fittings are available for you to choose from. Any combination of fittings may be used for the wire rope lanyard assemblies we supply.

A selection of fittings are available from stock – allowing you to make your own wire rope lanyard assemblies. We can advise correct assembly procedures for your application.



Eyelets

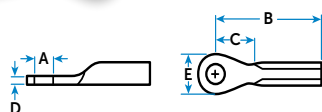

Eyelets allow for mounting the lanyard end using screws, rivets or bolts/nuts. For proper selection, please note the mounting hole size (A). Eyelets require specialized equipment for crimping.

STOCK CODE ZINC PLATED	STAINLESS STEEL STOCK CODE	Fits Bare Cable Diameter	Hole Diameter A	Length to Hole Center B	C	Thickness D	Outside Diameter E
EYE-47-157	EYE-47S-157	3/64	.157	.750	.260	.047	.330
EYE-47-160	EYE-47S-160	3/64	.160	.715	.315	.060	.320
EYE-47-1	EYE-47S-1	3/64	.190	.725	.215	.060	.340
EYE-62-129	EYE-62S-129	1/16	.129	.650	.340	.035	.380
EYE-62-1	EYE-62S-1	1/16	.190	.987	.317	.060	.460
EYE-62-194	EYE-62S-194	1/16	.194	.650	.340	.035	.380
EYE-62-204	EYE-62S-204	1/16	.204	.978	.400	.060	.460
EYE-62-2	EYE-62S-2	1/16	.260	.987	.317	.060	.460
EYE-62-315	EYE-62S-315	1/16	.315	1.00	.370	.060	.625
EYE-62-376	EYE-62S-375	1/16	.376	1.00	.370	.060	.625
EYE-62-438	EYE-62S-438	1/16	.438	1.00	.370	.060	.625
EYE-94-1	EYE-94S-1	3/32	.205	1.42	.470	.093	.500
EYE-94-2	EYE-94S-2	3/32	.250	1.42	.390	.090	.500
EYE-94-3	EYE-94S-3	3/32	.375	1.31	.450	.093	.750
EYE-94-500	EYE-94S-500	3/32	.500	1.31	.450	.093	.750
EYE-125-250	EYE-125S-250	1/8	.250	1.95	.480	.125	.580
EYE-125-316	EYE-125S-316	1/8	.316	1.95	.480	.125	.580
EYE-125-375	EYE-125S-375	1/8	.375	1.84	.540	.125	.850
EYE-125-500	EYE-125S-500	1/8	.500	1.84	.540	.125	.850

Unless otherwise noted, all dimensions are for reference only.



Mounting Tabs

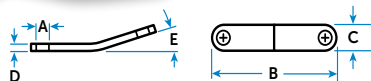

Mounting Tabs allow for mounting the lanyard end using screws, rivets or bolts/nuts. For proper selection, please note the mounting hole size (A). Mounting Tabs allow for greater freedom of movement of the wire rope lanyard itself, compared to eyelets.

STOCK CODE	Material	Fits Bare Cable Diameter	Hole Diameter A	Overall Length B	Width C	Thickness D	Bend Angle E
TAB-62-S	300 Series Stainless Steel	3/64 - 1/8	.194	1.262	.375	.062	15°
TAB-62S-203	304 Stainless Steel	3/64 - 1/8	.203	1-1/4*	.500	.060	20°
TAB-256S-F	300 Series Stainless Steel	3/64 - 1/8	.256	.860	.500	.062	30°
TAB-62S-281	304 Stainless Steel	3/64 - 1/8	.281	1-1/4*	.500	.060	20°
TAB-62-S1	300 Series Stainless Steel	3/64 - 1/8	.281	1.263	.375	.062	15°
TAB-26-437	Zinc Plated Steel	3/64 - 1/8	(1).437/(1).250	2.0	1.00	.060	No Bend
TAB-62S-285*	304 Stainless Steel	3/64 - 1/16	(1).285/(1).08	1.41*	.750		12°

**NOTE: TAB-62S-285 is teardrop shaped*



Get quote >>



Angic Global Solutions

1-888-872-0690

<https://www.AngicGlobal.com> Sales@AngicGlobal.com

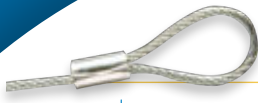

Sleeves for Loops

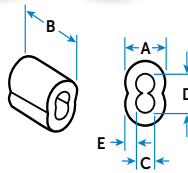

Lanyard cable is passed through the sleeve and fed back through to form a loop on the lanyard end. Sleeve is then crimped tight onto the cable. Use loops to attach to fasteners, pins or other components; or to loop the lanyard around itself and onto equipment.

STOCK CODE ALUMINUM	STOCK CODE 300 SERIES STAINLESS STEEL	STOCK CODE COPPER	Fits Cable Diameter	Dimensions				
				A	B	C	D	E
SLA-47	SLA-47-S	SLA-47-C	3/64	.149	.375	.055	.116	.045
SLA-62	SLA-62-S	SLA-62-C	1/16	.175	.375	.085	.160	.050
SLA-94	SLA-94-S	SLA-94-C	3/32	.281	.500	.121	.253	.080
SLA-125	SLA-125-2	SLA-125-C	1/8	.343	.625	.156	.313	.093

Unless otherwise noted, all dimensions are for reference only.

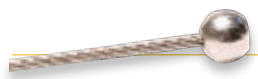

Ball Ends

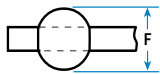

Use ball ends for "hanger"-type applications where assemblies can be removed easily. Ball ends allow the lanyard to swivel. Ball ends require specialized equipment for crimping.

STOCK CODE	Material	Fits Cable Diameter	Dimensions (F)	Specification
BALLEND-47S	Stainless Steel	3/64	.188	Commercial
BA3-1.5	Stainless Steel	3/64	.188	NAS494*
BALLEND-62S	Stainless Steel	1/16	.188	Commercial
BA3-2	Stainless Steel	1/16	.188	NAS494*
BALLEND-94-S	Stainless Steel	3/32	.250	Commercial
BA3-3	Stainless Steel	3/32	.250	NAS494*
BALLEND-125S	Stainless Steel	1/8	.313	Commercial
BA3-E	Stainless Steel	1/8	.313	NAS494*

Unless otherwise noted, all dimensions are for reference only.

** Made in USA - DFAR Compliant*



Ball & Shank



Use ball shanks for "hanger"-type applications where assemblies can be removed easily. Ball Shank ends allow the lanyard to swivel. Available to MS20664 specification or commercial grade. Ball shank ends require specialized equipment for crimping.

STOCK CODE	Material	Fits Cable Diameter	As	Bs	Specification
SHANK-47S	Stainless Steel	3/64	.112	.190	Commercial
SHANK-62S	Stainless Steel	1/16	.112	.190	Commercial
MS20664-C2	Stainless Steel	1/16	.112	.190	MS20664-C2
SHANK-94S	Stainless Steel	3/32	.143	.253	Commercial
MS20664-C3	Stainless Steel	3/32	.143	.253	MS20664-C3
SHANK-125S	Stainless Steel	1/8	.190	.315	Commercial
MS20664-C4	Stainless Steel	1/8	.190	.315	MS20664-C4

Unless otherwise noted, all dimensions are for reference only.



Double Shank Ball

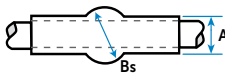

Available to MS20663 specification or commercial grade. Double Shank Ball ends require specialized equipment for crimping.

STOCK CODE	Material	Fits Cable Diameter	Dimensions		Specification
			As	Bs	
MS20663-C2	Stainless Steel	1/16	.112	.190	MS20663-C2
MS20663-C3	Stainless Steel	3/32	.143	.253	MS20663-C3
MS20663-C4	Stainless Steel	1/8	.190	.315	MS20663-C4

Unless otherwise noted, all dimensions are for reference only.



Stop Sleeves

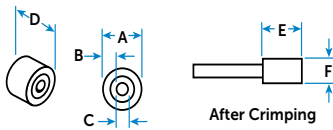

Stop sleeves are used in "hanger"-type applications where assemblies can be removed easily. A low cost end fitting!

STOCK CODE	Fits Bare Cable Diameter	Material	Dimensions				After Crimping	
			A	B	C	D	E	F
STP-47C	3/64	Copper	.172	.055	.063	.218	.273	.155
STP-62A	1/16	Aluminum	.247	.088	.075	.225	.340	.260
STP-94A	3/32	Aluminum	.347	.120	.110	.350	.610	.259
STP-125A	1/8	Aluminum	.343	.101	.140	.350	.522	.285

Unless otherwise noted, all dimensions are for reference only.



Threaded Ends

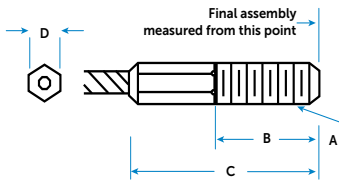

Threaded ends allow for panel-mounting as well as cable tightening.

STOCK CODE	Material	Fits Cable Diameter	Dimensions			
			A	B	C	D
TS47-50B	Brass	3/64 - 1/16	#10-24	1/2	1-1/8	5/32
TS47-50S	Stainless Steel	3/64 - 1/16	#10-24	1/2	1-1/8	5/32
TS47-100B	Brass	3/64 - 1/16	#10-24	1	1-5/8	5/32
TS47-100S	Stainless Steel	3/64 - 1/16	#10-24	1	1-5/8	5/32
TS47-125	Zinc Plated Steel	3/64 - 1/16	#10-32	1-1/4	1-7/8	5/32
TS47-125B	Brass	3/64 - 1/16	#10-32	1-1/4	1-7/8	5/32
TS47-125S	Stainless Steel	3/64 - 1/16	#10-32	1-1/4	1-7/8	5/32
TS62-75	Zinc Plated Steel	1/16 - 3/32	1/4-20	3/4	1-5/16	7/32
TS62-75B	Brass	1/16 - 3/32	1/4-20	3/4	1-5/16	7/32
TS62-75S	Stainless Steel	1/16 - 3/32	1/4-20	3/4	1-5/16	7/32
TS62-138	Zinc Plated Steel	1/16 - 1/8	1/4-28	1-3/8	2-3/16	7/32
TS62-138S	Stainless Steel	1/16 - 1/8	1/4-28	1-3/8	2-3/16	7/32
TS94-75	Zinc Plated Steel	3/32 - 1/8	1/4-20	3/4	1-9/16	7/32
TS94-75S	Stainless Steel	3/32 - 1/8	1/4-20	3/4	1-9/16	7/32
TS94-125	Zinc Plated Steel	3/32 - 1/8	1/4-20	1-1/4	2-1/16	7/32
TS94-125S	Stainless Steel	3/32 - 1/8	1/4-20	1-1/4	2-1/16	7/32
TS94-125-38	Zinc Plated Steel	3/32 - 3/16	3/8-16	1-1/4	2-1/4	5/16
TS94-125S-38	Stainless Steel	3/32 - 3/16	3/8-16	1-1/4	2-1/4	5/16
TS94-150	Zinc Plated Steel	3/32 - 1/8	1/4-20	1-1/2	2-5/16	7/32
TS94-150S	Stainless Steel	3/32 - 1/8	1/4-20	1-1/2	2-5/16	7/32
TS94-225	Zinc Plated Steel	3/32 - 3/16	3/8-16	2-1/4	3-1/4	5/16
TS94-225S	Stainless Steel	3/32 - 3/16	3/8-16	2-1/4	3-1/4	5/16
TS125-100	Zinc Plated Steel	1/8 - 5/32	5/16-18	1	1-15/16	9/32
TS125-100S	Stainless Steel	1/8 - 5/32	5/16-18	1	1-15/16	9/32
TS125-150	Zinc Plated Steel	1/8 - 5/32	5/16-24	1-1/2	2-7/16	9/32
TS125-150S	Stainless Steel	1/8 - 5/32	5/16-24	1-1/2	2-7/16	9/32
TS125-150-38	Zinc Plated Steel	1/8 - 3/16	3/8-24	1-1/2	2-1/2	5/16
TS125-150S-38	Stainless Steel	1/8 - 3/16	3/8-24	1-1/2	2-1/2	5/16
TS125-200	Zinc Plated Steel	1/8 - 5/32	5/16-18	2	2-15/16	9/32
TS125-200S	Stainless Steel	1/8 - 5/32	5/16-18	2	2-15/16	9/32

Unless otherwise noted, all dimensions are for reference only.





Thimbles

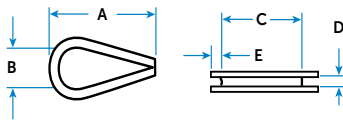

Thimbles are used in conjunction with a lanyard loop to increase cable life by increasing wear resistance as well as distributing the load on the cable over a larger area.

STOCK CODE	Fits Bare Cable Diameter	Material	Dimensions				
			A	B	C	D	E
TIM-62	1/16 - 5/64	CR Steel	.969	.35	.703	.094	.078
TIM-62S	1/16 - 5/64	300 Series S.S.	.969	.35	.703	.094	.078
TIM-94	3/32 - 1/8	CR Steel	1.000	.35	.703	.141	.078
TIM-94S	3/32 - 1/8	300 Series S.S.	1.000	.35	.703	.141	.078

Unless otherwise noted, all dimensions are for reference only.

New!



Carabiners

Carabiners are versatile quick-connect snap hooks. The opening gate is spring-loaded, automatically snaps closed and features an interlock tooth. Use with Wire Rope Lanyards, Nylon Lanyards, rope or other tethering methods. Carabiners without eyelets afford easy attachment to lanyards, while Carabiners with eyelets keep the lanyard or other tether in place at the bottom of the Carabiner. Available from stock in steel with zinc plating and stainless steel.

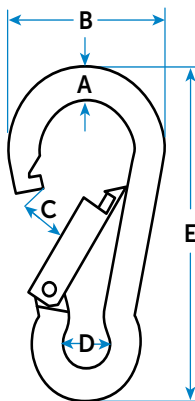

Carabiners

STOCK CODE	Material	Metric Sizes - all dimensions in millimeters					Approx. Weight/Pounds per 100 pieces
		A	B	C	D	E	
CARAB-187	Steel, Zinc Plated	5.0	26.5	7.0	8.0	50.0	3.48
CARAB-187S	316 Stainless	5.0	26.5	7.0	8.0	50.0	3.48
CARAB-250	Steel, Zinc Plated	6.0	30.0	7.5	8.5	60.0	5.95
CARAB-250S	316 Stainless	6.0	30.0	7.5	8.5	60.0	5.95
CARAB-312	Steel, Zinc Plated	8.0	40.5	10.0	12.0	80.0	13.78
CARAB-312S	316 Stainless	8.0	40.5	10.0	12.0	80.0	13.78
CARAB-375	Steel, Zinc Plated	9.0	45.0	10.5	14.0	90.0	20.04
CARAB-375S	316 Stainless	9.0	45.0	10.5	14.0	90.0	20.04

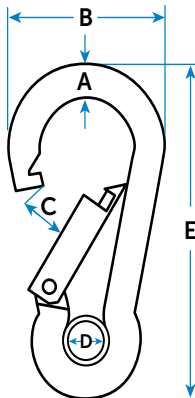

Carabiners – with Eyelets

STOCK CODE	Material	Metric Sizes - all dimensions in millimeters					Approx. Weight/Pounds per 100 pieces
		A	B	C	D	E	
CARABX-187	Steel, Zinc Plated	5.0	26.5	7.0	7.8	50.0	3.62
CARABX-187S	316 Stainless	5.0	26.5	7.0	7.8	50.0	3.62
CARABX-250	Steel, Zinc Plated	6.0	30.0	7.5	8.7	60.0	6.08
CARABX-250S	316 Stainless	6.0	30.0	7.5	8.7	60.0	6.08
CARABX-312	Steel, Zinc Plated	8.0	40.0	10.0	10.8	80.0	14.07
CARABX-312S	316 Stainless	8.0	40.0	10.0	10.8	80.0	14.07
CARABX-375	Steel, Zinc Plated	9.0	45.0	10.5	12.0	90.0	20.41
CARABX-375S	316 Stainless	9.0	45.0	10.5	12.0	90.0	20.41

Unless otherwise noted, all dimensions are for reference only.



STAINLESS
STOCKED

Bulk Cable

Bulk aircraft cable cut to length or on spools is available from stock in galvanized steel or stainless, bare or coated. Construction is 7x7 aircraft quality for strength and flexibility. Sold by the foot.

Bulk Cable

STOCK CODE Galvanized Steel	STOCK CODE Stainless Steel (300 Series)	SIZE/COATING 7 x 7 Construction	Minimum Breaking Strength (lbs.)	Approximate Weight/Pounds per 100 Ft.
GAC-47-B	SAC-47-B	3/64 Bare Cable	270	.42
GAC-47-P	SAC-47-P	3/64 PVC Coated To 1/16	270	.52
GAC-47-N	SAC-47-N	3/64 Nylon Coated To 1/16	270	.54
GAC-62-B	SAC-62-B	1/16 Bare Cable	480	.75
GAC-62-P	SAC-62-P	1/16 PVC Coated To 3/32	480	1.00
GAC-62-N	SAC-62-N	1/16 Nylon Coated To 3/32	480	1.20
GAC-94-B	SAC-94-B	3/32 Bare Cable	920	1.60
GAC-94-P	SAC-94-P	3/32 PVC Coated To 1/8	920	2.10
GAC-94-N	SAC-94-N	3/32 Nylon Coated to 1/8	920	2.30
GAC-125-B	SAC-125-B	1/8 Bare Cable	1700	2.85
GAC-125-P		1/8 PVC Coated To 3/16	1700	4.00
GAC-125-N		1/8 Nylon Coated to 3/16	1700	4.50

Unless otherwise noted, all dimensions are for reference only.

Cable Cutter & Crimp Tool

Make your own cable assemblies in house using this versatile and durable tool. The dual purpose Cutter/Crimping tool tightly crimps aluminum oval sleeves, and features a built-in cable cutter. Cuts cleanly without fraying the end of the cable.



WARNING: Always wear eye protection when using this tool.

Cable Cutter/Crimp Tool

STOCK CODE	Description	Crimping Range	Length	Weight Each (lbs.)
CCT-WCI	Cable Cutter/Crimp Tool	1/32", 3/64", 1/16"	9"	.75

Unless otherwise noted, all dimensions are for reference only.



Get quote »



pi

Angic Global Solutions

1-888-872-0690

<https://www.AngicGlobal.com> Sales@AngicGlobal.com



Light & Super Tough!

Nylon Lanyards™

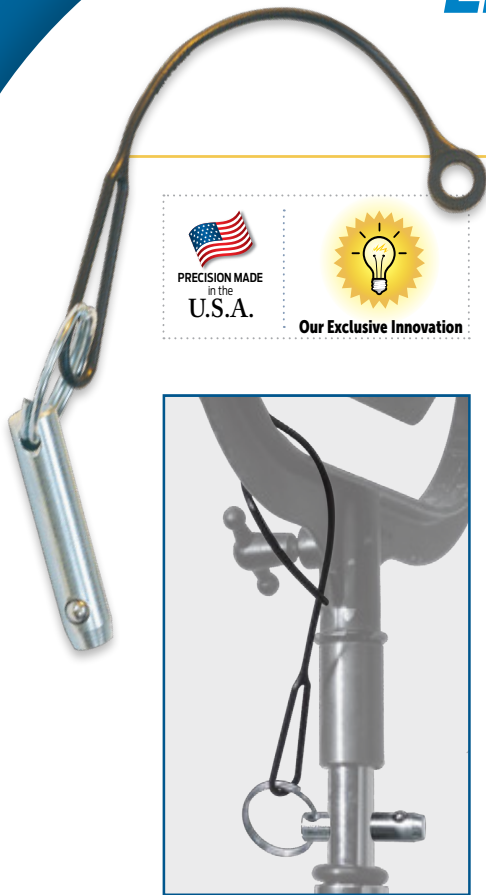

Keep pins, fasteners and other components where they belong with Nylon Lanyards™. This low cost alternative to steel lanyards offers light-duty retention and loss prevention. Available from stock in various styles and lengths. Made from super tough nylon resin. Available in fixed-end and U-lock styles with various configurations.

Standard

Supplied in either Type 1, Type 2 or Type 3 configurations with molded (fixed) loops and eyelets. Attach loop to rings of pins being retained. Rivet eyelet to equipment. Or, devise your own methods of attachment. These three styles offer unlimited possibilities! Stocked in 6", 8", 10" and 12" lengths.

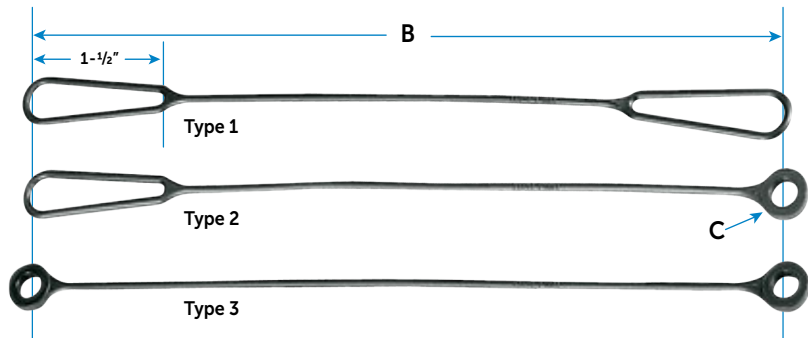

Fixed-End Nylon Lanyards

Packaged in 100 piece bags

STOCK CODE	SIZE Diameter x Length	Type	Approximate Break Strength (lbs.)	Length B	Eyelet I.D. C	Approximate Weight/Pounds per 100 Pieces
NL93F-6-1	.093 x 6"	Type 1	35	6.00	N/A	.30
NL93F-8-1	.093 x 8"	Type 1	35	8.00	N/A	.38
NL93F-10-1	.093 x 10"	Type 1	35	10.00	N/A	Not Stocked
NL93F-12-1	.093 x 12"	Type 1	35	12.00	N/A	.48
NL93F-6-2-20	.093 x 6"	Type 2	35	6.00	.20	.28
NL93F-6-2-26	.093 x 6"	Type 2	35	6.00	.26	.30
NL93F-8-2-20	.093 x 8"	Type 2	35	8.00	.20	Not Stocked
NL93F-8-2-26	.093 x 8"	Type 2	35	8.00	.26	.37
NL93F-10-2-20	.093 x 10"	Type 2	35	10.00	.20	Not Stocked
NL93F-10-2-26	.093 x 10"	Type 2	35	10.00	.26	.37
NL93F-12-2-20	.093 x 12"	Type 2	35	12.00	.20	Not Stocked
NL93F-12-2-26	.093 x 12"	Type 2	35	12.00	.26	.48
NL93F-6-3-2020	.093 x 6"	Type 3	35	6.00	.20	Not Stocked
NL93F-6-3-2026	.093 x 6"	Type 3	35	6.00	.20 & .26	.25
NL93F-6-3-2626	.093 x 6"	Type 3	35	6.00	.26	.31
NL93F-8-3-2020	.093 x 8"	Type 3	35	8.00	.20	Not Stocked
NL93F-8-3-2026	.093 x 8"	Type 3	35	8.00	.20 & .26	.33
NL93F-8-3-2626	.093 x 8"	Type 3	35	8.00	.26	.37
NL93F-10-3-2020	.093 x 10"	Type 3	35	10.00	.20	Not Stocked
NL93F-10-3-2026	.093 x 10"	Type 3	35	10.00	.20 & .26	.38
NL93F-10-3-2626	.093 x 10"	Type 3	35	10.00	.26	.38
NL93F-12-3-2020	.093 x 12"	Type 3	35	12.00	.20	Not Stocked
NL93F-12-3-2026	.093 x 12"	Type 3	35	12.00	.20 & .26	Not Stocked
NL93F-12-3-2626	.093 x 12"	Type 3	35	12.00	.26	.45

Nylon Lanyards continued on page 35

It's a snap!

Nylon Lanyards™

Nylon Lanyards
continued from page 34

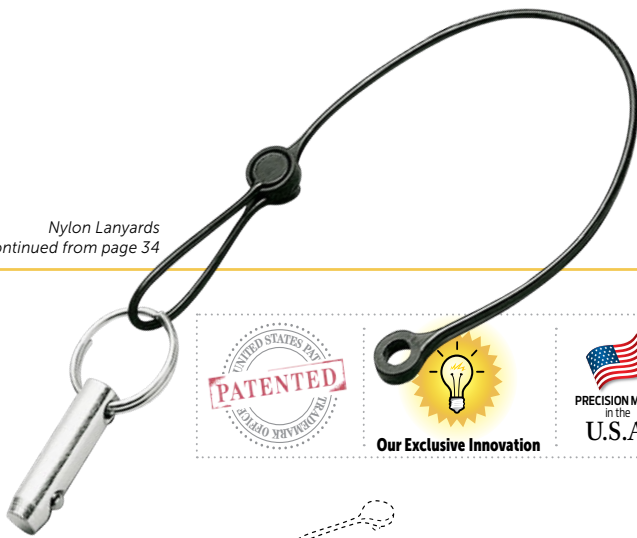

U-Lock Style U.S. Patent No. 5,784,760

One end is a loop, supplied open. Attach to component, then "snap" together! Loop is permanently locked. Available with either a molded loop or eyelet on the other end. Stocked in 10" (assembled) lengths.

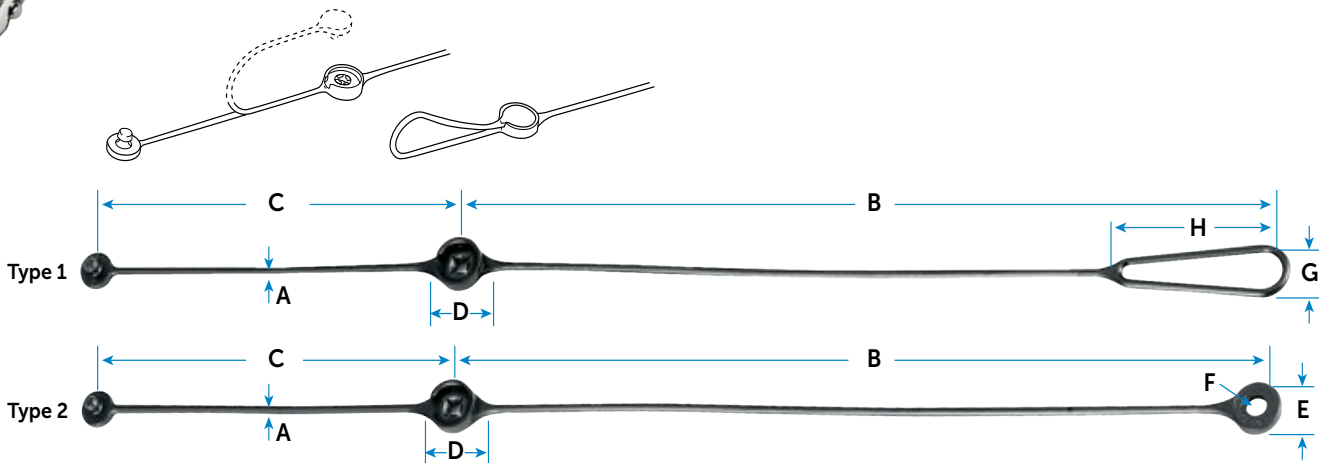

U-Lock Nylon Lanyards

Packaged in 100 piece bags

STOCK CODE	Type	DIMENSIONS								Assembled Length	Approx. Break Strength (lbs.)	Approximate Weight/Pounds per 100 Pieces
		A	B	C	D	E	F	G	H			
NL93-10-100	Type 1	.093	8"	4"	.50	--	--	0.34	1.50	10"	35	.569
NL93-10-125	Type 1	.093	7"	4"	.50	--	--	1.00	2.50	9"	35	.525
NL93-10-220	Type 2	.093	8"	4"	.50	.473	.20	--	--	10"	35	.575
NL93-10-226	Type 2	.093	8"	4"	.50	.473	.26	--	--	10"	35	.564

Unless otherwise noted, all dimensions are for reference only.

Press Lock Rivets

Press-Lock Rivets are a one-piece molded "rivet" to be used in conjunction with Nylon Lanyards. Insert through eyelet end of Lanyard and press into threaded, non-threaded, drilled or punched holes. Ribs deflect upon insertion and spring back for a secure lock. Made from 6/6 nylon in natural color.

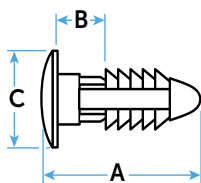
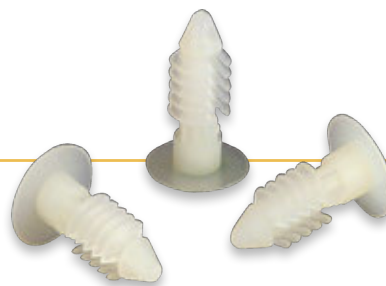

Press Lock Rivets

STOCK CODE	Size	Required Hole Size	DIMENSIONS			Approximate Weight/Pounds per 100 Pieces
			A	B	C	
PL-250-10	1/4 x 5/8	.250	.625	.125	.500	.1020
PL-250-12	1/4 x 3/4	.250	.750	.250	.500	.1265

Unless otherwise noted, all dimensions are for reference only.



Get quote >>



Angic Global Solutions

1-888-872-0690

<https://www.AngicGlobal.com> Sales@AngicGlobal.com





Locks itself on!

Bow-Tie Locking Cotters™

U.S. Patent No. 6,135,693 and D431,181



The Bow-Tie Locking Cotter™ works like a hair pin cotter but locks itself on! Push or pull cotter leg into hole, Bow-Tie snaps into a zero-tension locked position. It is released by lifting loop and sliding off, but reduces the risk of being accidentally knocked or vibrated off, as with hair pin cotters. Made from hard drawn wire with a protective and attractive zinc plated finish. Use in any hole location to ensure secure fastening.

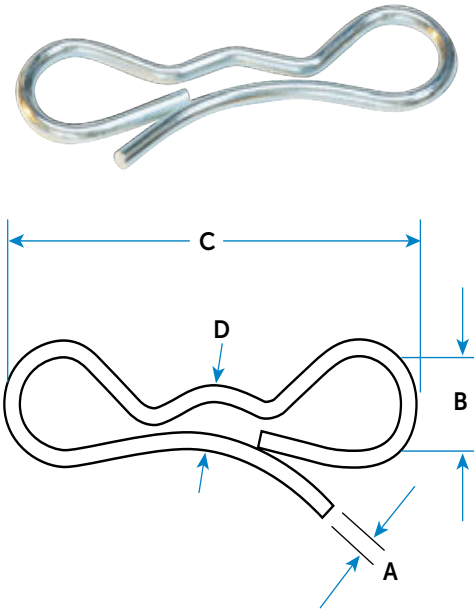

Bow-Tie Locking Cotter™ Pin Specs

Stock Code	Fits Shaft Sizes	Recommended				
		Minimum Hole Dia.	A	B	C	D
Bow-54	3/16	.072	.054	.182	1.000	.200
	1/4	.072				
Bow-72	1/4	.094	.072	.250	1.375	.260
	5/16	.094				
	3/8	.156				
Bow-91	5/16	.109	.091	.375	1.875	.305
	3/8	.125				
Bow-91-8	7/16	.125	.091	.375	1.875	.356
	1/2	.141				
Bow-120	7/16	.141	.120	.563	2.750	.450
	1/2	.156				
Bow-120-10	5/8	.156	.120	.562	2.750	.490
Bow-148-10	5/8	.203	.148	.687	3.578	.540
Bow-120-12	3/4	.156	.120	.562	2.750	.545
Bow-148-12	3/4	.203	.148	.687	3.578	.600
Bow-177-16	1	.218	.177	.875	4.578	.762

Unless otherwise noted, all dimensions are for reference only.

Bow-Ties - Zinc Plated

STOCK CODE	Fits Shaft Size	Approximate Weight/Pounds per 100 Pieces
Bow-54	3/16 - 1/4	.15
Bow-72	1/4 - 3/8	.39
Bow-91	5/16 - 3/8	.89
Bow-91-8	7/16 - 1/2	.87
Bow-120	7/16 - 1/2	2.20
Bow-120-10	5/8	2.20
Bow-148-10	5/8	4.27
Bow-120-12	3/4	2.16
Bow-148-12	3/4	4.23
Bow-177-16	1	7.96

Bow-Ties - 410 Stainless Steel

STOCK CODE	Fits Shaft Size	Approximate Weight/Pounds per 100 Pieces
Bow-72S-410	1/4 - 3/8	.39
Bow-91S-410	5/16 - 3/8	.89

Bow-Tie Demo

- To install, push or pull Bow-Tie into hole.
- Bow-Tie snaps into a zero-tension locked position!
- You can even flip the Bow-Tie over the end...it stays locked!
- Pull locking loop up and over to release.

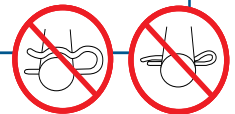

Bow-Tie Locking Cotters™ continued on page 37

Stock Bow-Tie Locking Cotters™ Shown at approximate actual size.

Continued from page 36



Bow-54
Fits 3/16" - 1/4" Shafts*

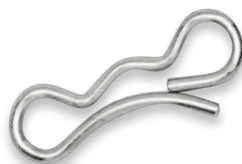

Bow-72
Fits 1/4" - 3/8" Shafts*

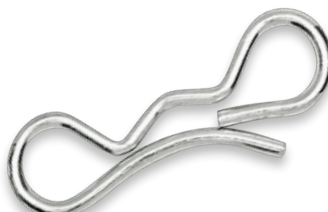

Bow-91
Fits 5/16" - 3/8" Shafts*

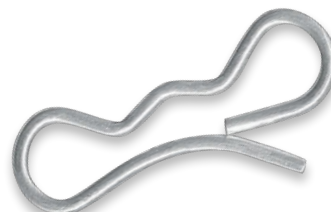

Bow-91-8
Fits 7/16 - 1/2" Shafts*

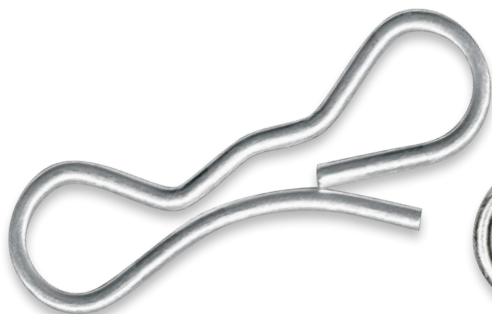

Bow-120
Fits 7/16" - 1/2" Shafts*

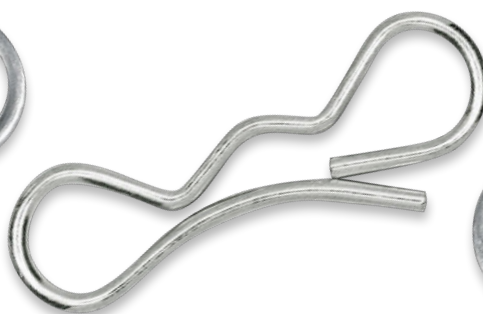

Bow-120-10
Fits 5/8" Shafts*

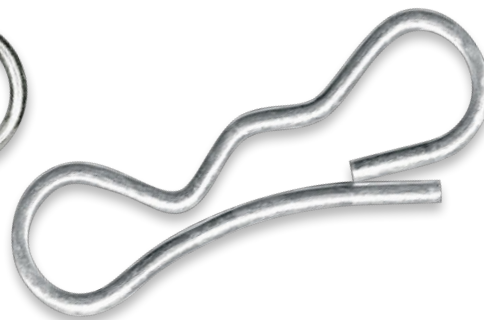

Bow-120-12
Fits 3/4" Shafts*

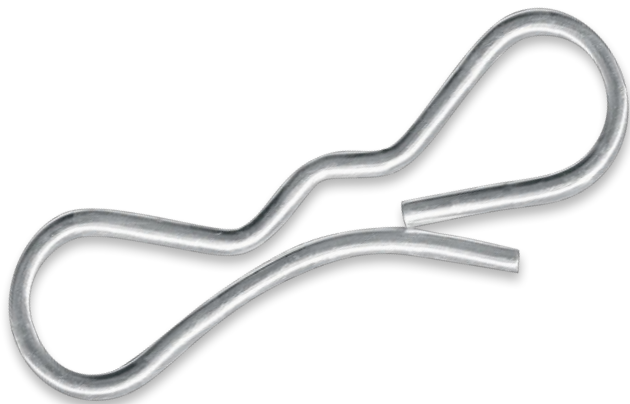

Bow-148-10
Fits 5/8" Shafts*

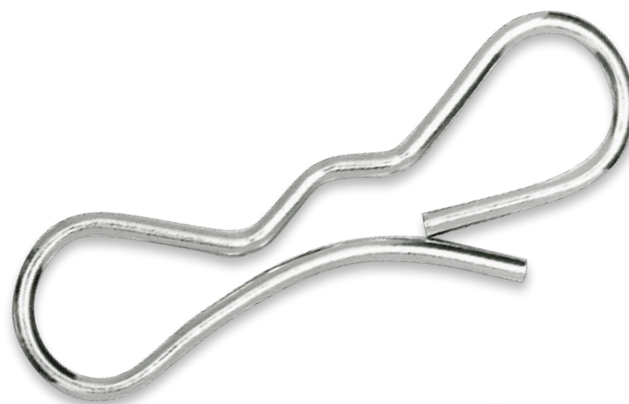

Bow-148-12
Fits 3/4" Shafts*

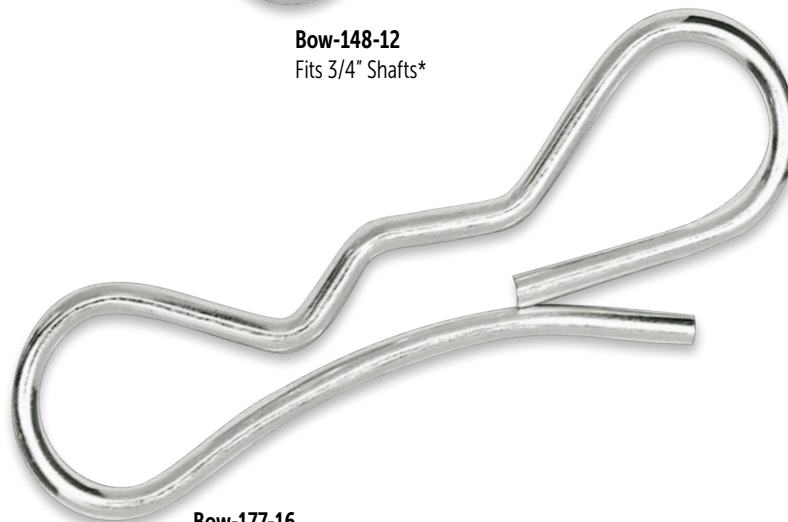

Bow-177-16
Fits 1" Shafts*

* See recommended hole sizes on page 36.



Get quote »



Angic Global Solutions

<https://www.AngicGlobal.com> Sales@AngicGlobal.com

1-888-872-0690



Revolutionary Rue Ring™ Locking Cotter

Our Original Design



PIVOTPOINT
INC.
PINS > CABLES > SOLUTIONS
Our Original Design



Revolutionary Rue Ring™ Locking Cotter surrounds the shaft and lock on, making them one of the safest cotters available. Best used on light to medium applications. Rue Ring™ Locking Cotter installs fast without tools. Don't be fooled by imitations! Our original proven design and dimensions ensure proper fit and function.

A manual secondary lock tensions the Rue Ring™ tight and dampens vibration. Made of hard drawn wire, zinc plated or stainless steel 302. Easy to install - easy to remove.

NEW Lift Loop Style

See stock code RUE-24LL

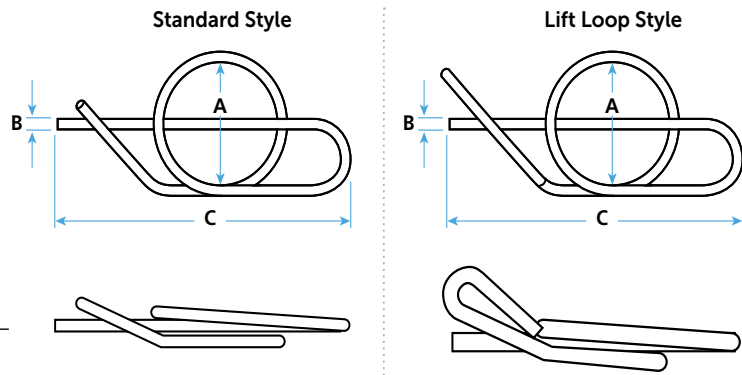

Rue Rings™ - Zinc Plated

STOCK CODE	Size	Wire Diameter	Approximate Weight/Pounds per 100 Pieces
RUE-8	1/4	.041	.11
RUE-9H	1/4 Heavy	.054	.18
RUE-10	5/16	.047	.18
RUE-14	3/8	.054	.23
RUE-19	7/16" Heavy	.072	.55
RUE-22	1/2	.062	.41
RUE-24	1/2 Heavy	.072	.68
RUE-24LL	1/2 - Lift Loop	.072	.71
RUE-30	5/8	.072	.79
RUE-34	3/4	.080	1.00
RUE-36	3/4 Heavy	.091	1.30
RUE-40	7/8 Heavy	.105	2.06
RUE-42	1	.105	2.28

Rue Ring™ Locking Cotter Pin Specs

Stock Code	Fits Shaft Sizes	Dimensions		
		A	B	C
RUE-8	1/4	.267/.257	.041	.844
RUE-9H	1/4 Heavy	.270/.260	.054	.936
RUE-10	5/16	.330/.320	.047	1.044
RUE-14	3/8	.392/.382	.054	1.214
RUE-19	7/16 Heavy	.447/.457	.072	1.411
RUE-22	1/2	.520/.510	.062	1.420
RUE-24	1/2 Heavy	.520/.510	.072	1.456
RUE-24LL	1/2 - Lift Loop	.520/.510	.072	1.456
RUE-30	5/8	.645/.635	.072	1.690
RUE-34	3/4	.770/.760	.080	2.081
RUE-36	3/4 Heavy	.770/.760	.091	2.166
RUE-40	7/8 Heavy	.895/.885	.105	2.506
RUE-42	1	1.020/1.010	.105	2.756

Unless otherwise noted, all dimensions are for reference only.

Rue Rings™ - Stainless Steel

STOCK CODE	Size	Wire Diameter	Approximate Weight/Pounds per 100 Pieces
RUE-8-S	1/4	.041	.11
RUE-10-S	5/16	.047	.18
RUE-14-S	3/8	.054	.23
RUE-24-S	1/2 Heavy	.072	.68
RUE-30-S	5/8	.072	.79
RUE-36-S	3/4 Heavy	.091	1.30

Rue Ring™ Demo

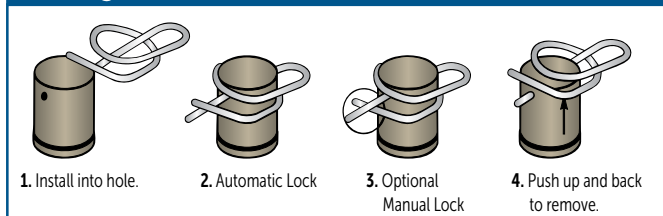

Rue Ring™ Locking Cotter continued on page 39

Hole Placement End shaft use only

Continued from page 38

Rue Ring™ Locking Cotters will retro fit most standard applications without design changes.

Total width of any Rue Ring™ equals 3 of its wire diameters. The straight wire shaft which goes through the pin hole is one, plus two additional wire loops, one on each side, front and back as illustrated.

Recommended hole size is 2 times the wire diameter of the selected Rue Ring™. This leaves the Rue Ring™ short of interfering with the shaft effective length.

Recommended web thickness is a minimum of 1 wire diameter and a maximum of 2 wire diameters. A thicker web results in more holding power, but makes installation and removal more difficult.

Total Width Equals 3 Wire Diameters

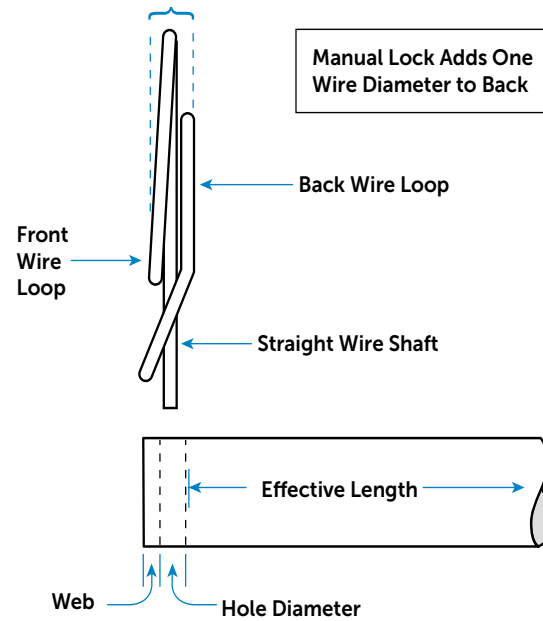

Stock Rue Ring™ Locking Cotters Shown at approximate actual size.

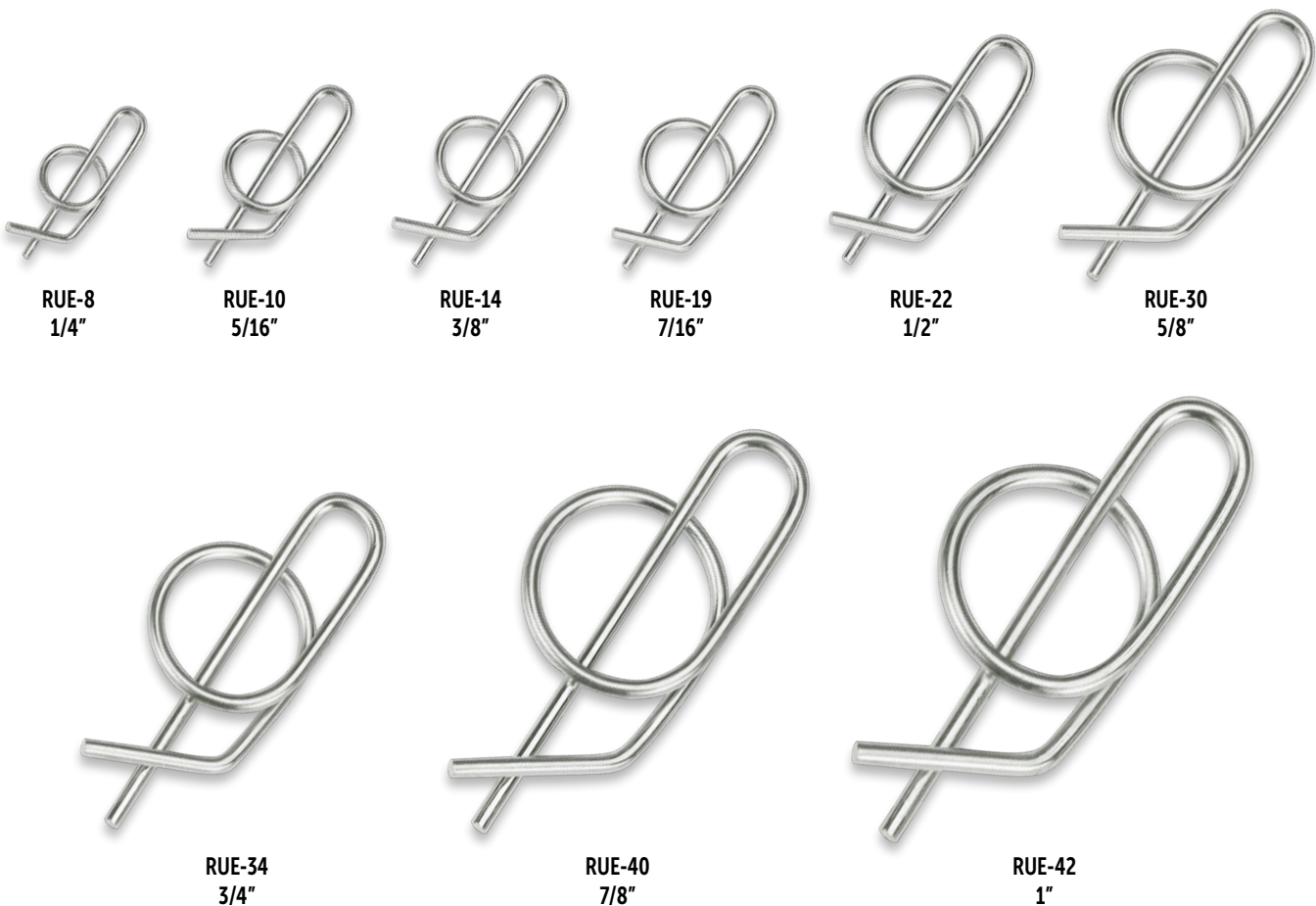

Get quote »



pi Angic Global Solutions

<https://www.AngicGlobal.com> Sales@AngicGlobal.com

1-888-872-0690



Strong, secure & reusable

Hair Pin Cotters

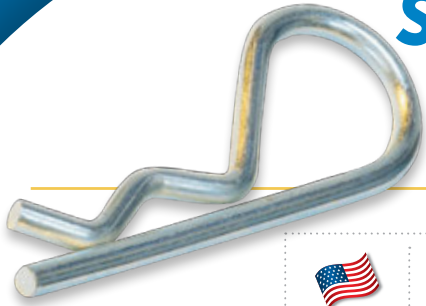

FOR MORE SECURE FASTENING, TRY OUR

- Bow-Tie Locking Cotters™
Page 36-37
- Rue Ring Locking Cotters
Page 38-39



A spring-type cotter made to be reusable. Pivot Point hair pin cotters are made exclusively to our exact specifications. Designed to be strong and secure, these fasteners are economical and widely used. It is important to select the correct size because misuse causes fatigue and will result in loss of the fastener. Consult our use chart below and ask us about proper hole size . . . we're glad to help!

Made from hard drawn wire, zinc plated or stainless type 302.

Hair Pin Cotter Pin Specs

Pivot Point Standard			Cross Reference/Replaces		
Stock Code	Wire Diameter	Overall Length	WW Number	Wire Diameter	Overall Length
HAIR-1	.047	.594	221	.047	.594
HAIR-2	.054	.969	223	.042	1.000
HAIR-4	.072	1.188	213	.080	1.188
HAIR-5	.091	1.625	203	.094	1.625
HAIR-6	.091	2.000	228	.094	2.000
HAIR-8	.120	2.375	211	.125	2.563
HAIR-10	.148	2.750	210	.148	2.938
HAIR-12	.177	3.500	229	.177	3.500

Unless otherwise noted, all dimensions are for reference only.

Hair Pin Cotters - Zinc Plated

STOCK CODE	Wire Diameter	Use on Shaft Size	Approximate Weight/Pounds per 100 Pieces
HAIR-1	.047	1/8 - 3/16	.06
HAIR-2	.054	3/16 - 1/4	.14
HAIR-4	.072	1/4 - 3/8	.30
HAIR-5	.091	5/16 - 3/8	.66
HAIR-6	.091	3/8 - 1/2	.88
HAIR-8	.120	1/2 - 9/16	1.68
HAIR-10	.148	5/8 - 3/4	3.04
HAIR-12	.177	7/8 - 1	5.58

Hair Pin Cotters - Stainless Steel

STOCK CODE	Wire Diameter	Use on Shaft Size	Approximate Weight/Pounds per 100 Pieces
HAIR-1-S	.047	1/8 - 3/16	.06
HAIR-2-S	.054	3/16 - 1/4	.14
HAIR-4-S	.072	1/4 - 3/8	.30
HAIR-5-S	.091	5/16 - 3/8	.66
HAIR-6-S	.091	3/8 - 1/2	.88
HAIR-8-S	.120	1/2 - 9/16	1.68

Stock Hair Pin Cotters

Shown at approximate actual size.

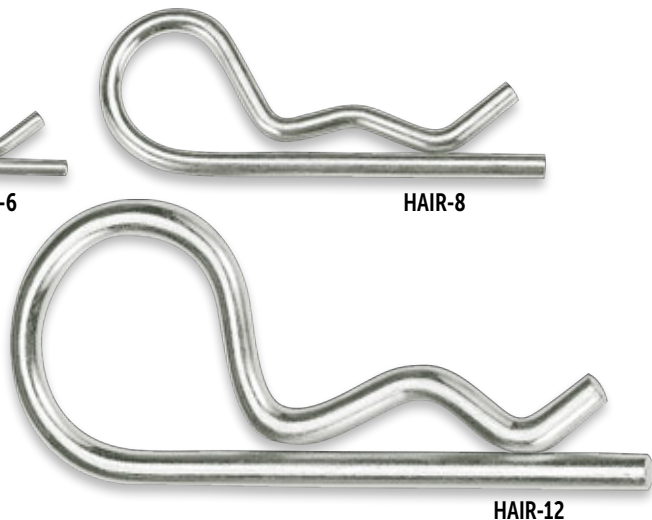

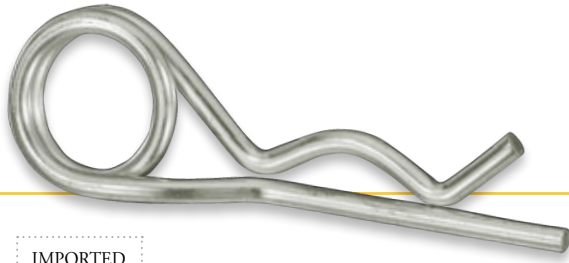

IMPORTED

Double Loop Hair Pin Cotters

A double loop adds flexibility for a wider fit range. Stresses are evenly spread throughout the loop giving longer life and more repeatability. Made from hard drawn wire, zinc plated, high quality.

Double Loop Hair Pin Cotters

Available in other sizes - call for pricing.

STOCK CODE	Use on Shaft Size	Wire Diameter	Overall Length	Approximate Weight/Pounds per 100 Pieces
HAIR-7DB	5/8 - 3/4	3 mm (.118)	3.00	2.60
HAIR-9DB	7/8 - 1	4 mm (.158)	3.70	6.40

Unless otherwise noted, all dimensions are for reference only.



Easy Semi-Locking Design

Infinity S-Hooks™



The Infinity S-Hook's™ innovative design allows you to connect components quickly and securely without tools! This time and labor saving fastener snaps on and off without bending or pinching ends. Made from hard drawn wire with an attractive zinc finish. Use the Infinity S-Hook™ to connect chain, cable assemblies, lanyards, pins and more. The possibilities are infinite!

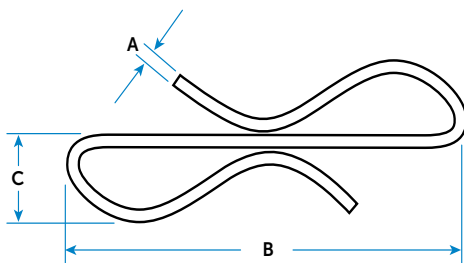

Infinity S-Hooks™

STOCK CODE	A	B	C	Approximate Weight/Pounds per 100 Pieces
FINS-120	.12	2.60	0.66	2.23

CHOOSE THE INFINITY S-HOOK™

- Quick connector
- Easy on & off
- No tools needed
- Secure
- Tangle free storage
- Reusable



Infinity S-Hook™ Demo



1. Attach chain or other component.



2. Snap into place! Stays secure.



3. Snap out to remove.



Get quote »



Angic Global Solutions

<https://www.AngicGlobal.com> Sales@AngicGlobal.com

1-888-872-0690



Easy and versatile



S-Hooks

Pivot Point ductile S-Hooks are an easy-to-use versatile fastener. Made from low-carbon steel wire, zinc plated. Available in stock sizes as shown full scale.

S-Hooks - Zinc Plated

STOCK CODE	Overall Length x Wire Diameter	Approximate Weight/Pounds per 100 Pieces
S-6	3/4 x .080	0.26
S-8	7/8 x .091	0.41
S-10H	1 x .105	0.60
S-12	1-1/8 x .105	0.68
S-14	1-1/4 x .120	1.03
S-16H	1-1/2 x .177	2.50
S-18	1-5/8 x .135	1.63
S-20	2-1/8 x .148	2.78

Unless otherwise noted, all dimensions are for reference only.

**DON'T MISS
OUR EXCLUSIVE
Infinity S-Hook**
Page 41



Stock S-Hooks Shown at approximate actual size.



S-6



S-8



S-10H



S-12



S-14



S-16H



S-18



S-20

Great for fabric & canvas!

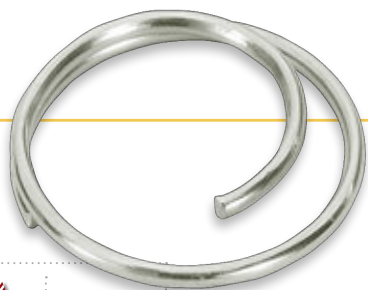

Circle Cotters

This cotter is wound or turned on from the middle out. Start by threading the open wire end inside the circle into the hole on shaft or pin. Keep turning the ring until it snaps into place. To remove, start turning the circle again in the same direction and it comes right off.

Very secure fasteners, circle cotters are used where sharp ends are not allowed. Smooth all around, this fastener is ideal for applications associated with fabric.

Made from hard drawn wire, zinc plated or stainless type 302.



Circle Cotters - Zinc Plated

STOCK CODE	Dimensions O.D. x Wire Diameter	Use on Diameter	Approximate Weight/Pounds per 100 Pieces
CC-3	5/8 x .048	3/16 - 1/4	.14
CC-5	3/4 x .048	1/4 - 5/16	.16
CC-7	1 x .060	3/8 - 7/16	.40
CC-9	1-1/8 x .072	7/16 - 1/2	.62

Unless otherwise noted, all dimensions are for reference only.

Circle Cotters - Stainless Steel

STOCK CODE	Dimensions O.D. x Wire Diameter	Use on Diameter	Approximate Weight/Pounds per 100 Pieces
CC-3-S	5/8 x .048	3/16 - 1/4	.14
CC-5-S	3/4 x .048	1/4 - 5/16	.16
CC-7-S	1 x .060	3/8 - 7/16	.40
CC-9-S	1-1/8 x .072	7/16 - 1/2	.62

Unless otherwise noted, all dimensions are for reference only.

Stock Circle Cotters Shown at approximate actual size.

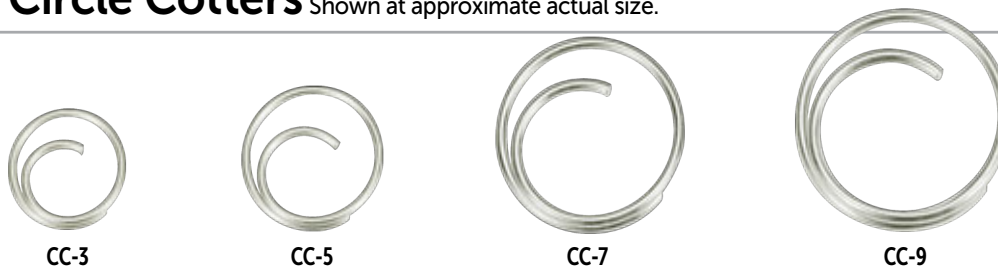

Kickout Rings

Kickout Rings are a type of circle cotter with a "kick-out" design that is made for speed and economy. Easily removable, this cotter can be installed fast by inserting the "kick-out" end into hole on pin or shaft and winding it through until it snaps into place. To remove, just start winding again.

This is a very secure cotter. Wound 1-3/4 coil, Kickout Cotter Rings are available in two sizes made from hard drawn wire, zinc plated or stainless type 302.

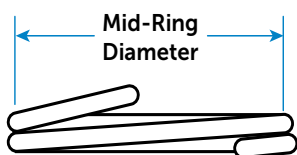

Kickout Rings

STOCK CODE Zinc Plated	STOCK CODE Stainless Steel	Size Ring Diameter x Wire Diameter	Approximate Weight/Pounds per 100 Pieces
KIC-172	KIC-172-S	1 x .072	.65
KIC-12580	KIC-12580-S	1-1/4 x .080	.97

Unless otherwise noted, all dimensions are for reference only.



Get quote >>



Angic Global Solutions

<https://www.AngicGlobal.com> Sales@AngicGlobal.com

1-888-872-0690





Split Key Rings

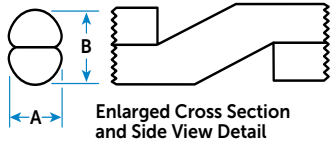

Pivot Point Split Key Rings are high quality, nickel plated steel designed to lay flat. Wire is half-circle shape and wound with the flat surfaces together. Construction is a full two turns with a "dog leg" jog where the ends meet. This design offers a smooth appearance and prevents the ends from "catching". Used as key rings, cotters, and attachments for lanyards; these rings are strong and attractive.

Split Rings - Nickel Plated

STOCK CODE	Approx. Fractional Size	Approx. Metric* Size	Approx. O.D.	Approx. I.D.	A	B	Approximate Weight/Pounds per 100 Pieces
RING-1M		9mm	0.354	0.286	.034	.053	0.11
RING-1	3/8		0.430	0.328	.051	.074	0.11
RING-3	13/32		0.484	0.382	.051	.074	0.12
RING-5	7/16		0.542	0.428	.057	.083	0.18
RING-7	1/2		0.604	0.460	.072	.105	0.30
RING-8M		16mm	0.630	0.524	.053	.080	0.15
RING-9	9/16		0.670	0.526	.072	.105	0.34
RING-11	5/8		0.740	0.596	.072	.112	0.38
RING-12M		20mm	0.787	0.677	.055	.084	0.22
RING-13	3/4		0.875	0.707	.084	.120	0.58
RING-13L	3/4		0.880	0.731	.072	.112	0.42
RING-14M		24mm	0.945	0.805	.070	.112	0.40
RING-15	7/8		0.970	0.802	.084	.120	0.63
RING-16M		26mm	1.024	0.876	.074	.102	0.48
RING-17	1		1.100	0.946	.077	.120	0.73
RING-17M		28mm	1.102	0.942	.080	.117	0.60
RING-17L*	1		1.100	0.956	.072	.120	0.58
RING-18M		29mm	1.142	0.962	.090	.117	0.75
RING-19	1 1/8		1.250	1.062	.094	.138	1.08
RING-20M		34mm	1.339	1.139	.100	.140	1.10
RING-21	1 1/4		1.375	1.147	.114	.150	1.48
RING-23	1 3/8		1.480	1.264	.108	.163	1.60
RING-25	1 1/2		1.640	1.396	.122	.185	2.30
RING-27	1 3/4		1.865	1.635	.115	.185	2.65
RING-29	2		2.240	2.000	.120	.165	3.20

Unless otherwise noted, all dimensions are for reference only.
* Zinc plated finish



Basic Rings

These basic rings are a low cost alternative to Split Key Rings and are often used as ring-grips in various applications, including pins such as Detent Ring Pins. Available in either hard drawn wire with an attractive zinc plated finish or corrosion resistant stainless steel.

Basic Rings - Zinc Plated

STOCK CODE	Size Ring Dia. x Wire Dia.	Approximate Weight/Pounds per 100 Pieces
DR-8762B	7/8 x .062	.0425
DR-172B	1 x .072	.0667
DR-12580B	1-1/4 x .080	.0915

Unless otherwise noted, all dimensions are for reference only.

Basic Rings - Stainless Steel

STOCK CODE	Size Ring Dia. x Wire Dia.	Approximate Weight/Pounds per 100 Pieces
DR-8762B-S	7/8 x .062	.0425
DR-172B-S	1 x .072	.0667
DR-12580B-S	1-1/4 x .080	.0915

Unless otherwise noted, all dimensions are for reference only.

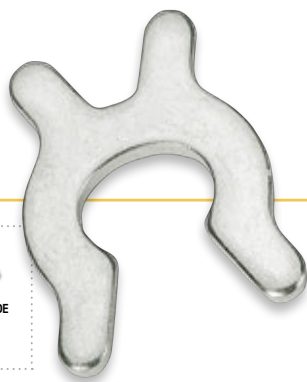

Crimp Ring Retainers

(X-Washers)



Here's a strong and easy to use alternative to retaining rings. Applied in a groove on shaft or pin, crimp ring retainers are squeezed into place with a pliers. Remove by squeezing the top ears to reopen the ring. Heavy construction in mild steel offers strong retention. No sharp edges and minimum clearances are additional benefits. Unlike standard retaining rings, the deep groove-seat affords greater retention and thrust-load.

Crimp Ring Retainers - Zinc Plated

STOCK CODE	Approximate Dimensions						Recommended			Approximate Weight/Pounds per 100 Pieces
	A	Thickness	C	D	E	F	Shaft Size G	Groove Seat Dia. H	Groove Width J	
CRR-5	.086	.025	.320	.406	.210	.406	5/32	.086	.031	.06
CRR-6	.098	.055	.364	.490	.297	.475	3/16	.093	.062	.15
CRR-8	.130	.055	.430	.575	.359	.556	1/4	.125	.062	.18
CRR-10	.164	.065	.523	.687	.422	.665	5/16	.156	.075	.36
CRR-12	.190	.065	.593	.745	.437	.730	3/8	.187	.075	.41
CRR-14	.222	.075	.622	.776	.469	.775	7/16	.218	.083	.48
CRR-16	.256	.075	.698	.905	.500	.890	1/2	.250	.083	.61
CRR-18	.285	.075	.822	.986	.563	.984	9/16	.279	.083	.74
CRR-20	.317	.089	.872	1.100	.609	1.078	5/8	.311	.097	.99
CRR-22	.347	.089	.948	1.190	.688	1.188	11/16	.341	.097	1.26
CRR-24	.381	.089	1.060	1.297	.797	1.281	3/4	.375	.097	1.51

Unless otherwise noted, all dimensions are for reference only.

+ .000/- .005 + .005/- .000
Recommended Tolerances

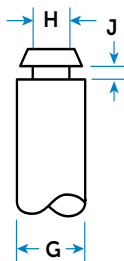
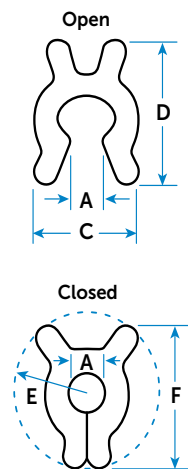

Crimp Ring Retainer Demo

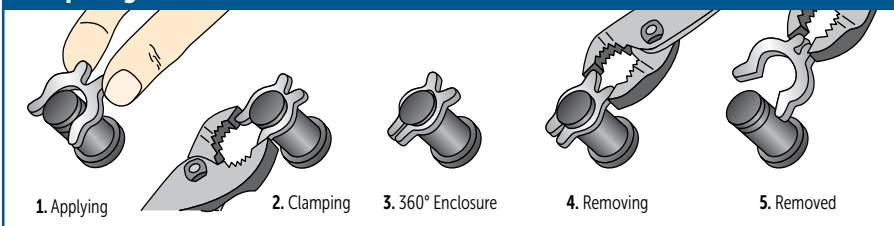

Stock Crimp Ring Retainers Shown at approximate actual size.

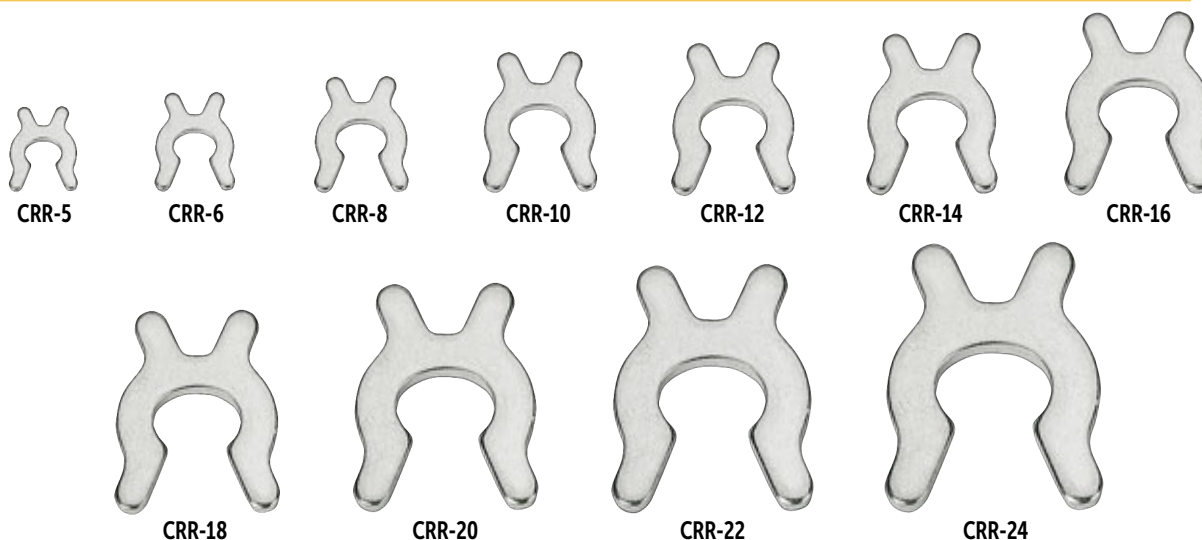

Get quote >>



Angic Global Solutions

<https://www.AngicGlobal.com> Sales@AngicGlobal.com

1-888-872-0690

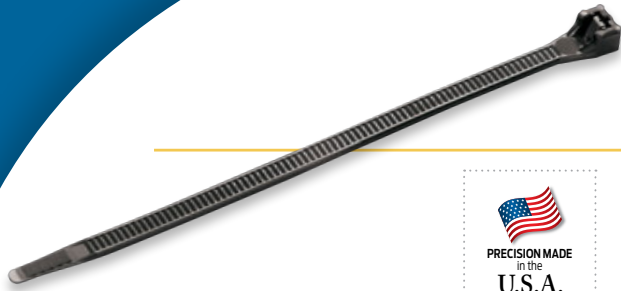

Cable Ties

UL Recognized
File No. E125869

Pivot Point Cable Ties feature an advanced locking mechanism which offers low insertion with high pull-out force. The stepped design locks against the strap's serrations for superior locking power.

The strap has finely molded serrations for total adjust-ability within a fastening range. The elimination of ejector pin marks along the length of the strap promotes smooth pull-through. Also, the strap has rounded edges on the outer rails to enhance low drag coefficient and minimum surface abrasion.

The tail is a tapered, bent tip with ribbed finger grips. These features encourage non-slip insertion and fast assembly.

The head has been designed with a low profile for an attractive appearance. This also reduces snagging in tight spaces. With gusset-style reinforcement, the neck is strengthened where the head joins the strap.

Made of 100% 6/6 nylon in natural or UV black.

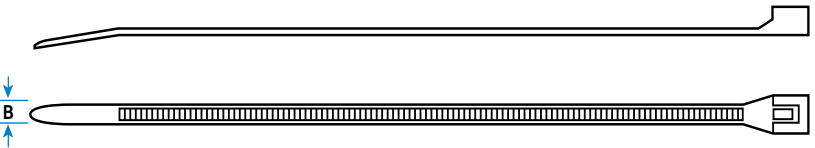

NOTE: Dimensions of the above cable ties may vary slightly depending upon the environment in which they are stored. In an environment with a high relative humidity (RH), nylon ties will absorb moisture and the dimensions will slightly increase. Conversely, if the ties are kept in an environment with low RH, the dimensions will slightly decrease. Molding conditions and post-mold shrinkage could also affect the dimensions. Unless noted, all dimensions are for reference only.

Cable Tie Specs

Stock Code	Nominal Length (in.)	Tensile Strength (lbs.)	Max. Capture Diameter	Width B
4-18	4	18	13/16"	.09
6-18	5	18	1-1/4"	.10
8-18	8	18	2"	.10
6-30	5	40	1-1/4"	.14
8-30	8	40	2-3/16"	.14
8-75	7	50	1-13/16"	.19
11-75	11	50	2-15/16"	.19
14-75	14	50	4"	.19
8-120	8	120	2"	.30
15-120	14	120	4"	.30
12-175	11	120	2-15/16"	.30
18-175	18	175	4-11/16"	.35
24-175	24	175	7"	.35

Cable Ties - Natural Color & UV Black

Packaged 50, 100 or 1000 piece bags.
No broken bag quantities please.

STOCK CODE	Tie Length x Tensile Strength	Material Color	Maximum Capture Diameter (inches)	Approximate Weight/Pounds per 100 Pieces	Cross Reference Guide					
					Catamount P/N	Tyton P/N	Dennison P/N	Richco P/N	T&B P/N	Panduit P/N
4-18-N	4" x 18 lb.	Natural	13/16"	0.068	L-4-18-9-C	T18R-C	8434	WIT-18R	TY523M	PLT1M-C
4-18-UV	4" x 18 lb.	UV Black	13/16"		L-4-18-0-C	T18R-0-C	8435	WIT-18RUVB	TY523MX	PLT1M-CO
6-18-N	5" x 18 lb.	Natural	1-1/4"	0.09		T18I-C		WIT-18L	TY52315M	PLT1.5M-C
6-18-UV	5" x 18 lb.	UV Black	1-1/4"			T18I-0-C		WIT-18LUVB	TY52315MX	PLT1.5M-CO
8-18-N	8" x 18 lb.	Natural	2"	0.122	L-8-18-9-C	T18L-C	10328	WIT-18V	TY5232M	PLT2M-C
8-18-UV	8" x 18 lb.	UV Black	2"		L-8-18-0-C	T18L-0-C	10330	WIT-18VUVB	TY5232MX	PLT2M-CO
6-30-N	5" x 40 lb.	Natural	1-1/4"	0.144	L-5-30-9-C	T30R-C	8383	WIT-30R	TY524M	PLT1.5I-C
6-30-UV	5" x 40 lb.	UV Black	1-1/4"		L-5-30-0-C	T30R-0-C	8384	WIT-30RUVB	TY524MX	PLT1.5I-CO
8-30-N	8" x 40 lb.	Natural	2-3/16"	0.178	L-8-40-9-C	T30M-C	8385	WIT-30XL	TY5242M	PLT2I-C
8-30-UV	8" x 40 lb.	UV Black	2-3/16"		L-8-40-0-C	T30M-0-C	8386	WIT-30XLUVB	TY5242MX	PLT2I-CO
8-75-N	7" x 50 lb.	Natural	1-3/16"	0.28		T50R-C		WIT-50R		
8-75-UV	7" x 50 lb.	UV Black	1-3/16"			T50R-0-C		WIT-50RUVB		
11-75-N	11" x 50 lb.	Natural	2-15/16"	0.385	L-11-50-9-C	T50I-C	8859	WIT-60R	TY5253M	PLT3S-C
11-75-UV	11" x 50 lb.	UV Black	2-15/16"		L-11-50-0-C	T50I-0-C	8930	WIT-60RUVB	TY5253MX	PLT3S-CO
14-75-N	14" x 50 lb.	Natural	4"	0.488	L-14-50-9-C	T50L-C	8427	WIT-50L	TY528M	PLT4S-C
14-75-UV	14" x 50 lb.	UV Black	4"		L-14-50-0-C	T50L-0-C	8428	WIT-50LUVB	TY528MX	PLT4S-CO
8-120-N	8" x 120 lb.	Natural	2"	0.64						
8-120-UV	8" x 120 lb.	UV Black	2"							
12-175-N	11" x 120 lb.	Natural	2-15/16"	1.028		T120I				PLT3H-L
12-175-U	11" x 120 lb.	UV Black	2-15/16"			T120I-0				PLT3H-LO
15-120-N	14" x 120 lb.	Natural	4"	1.204	L-14-120-9-C	T150R	10038	WIT-175S	TY527M	PLT4H-L
15-120-UV	14" x 120 lb.	UV Black	4"		L-14-120-0-C	T150R-0	10039	WIT-175SUVB	TY527MX	PLT4H-LO
18-175-N	18" x 175 lb.	Natural	4-11/16"	1.556	L-18-120-9-L				TY5275M	PLT5H-L
18-175-UV	18" x 175 lb.	UV Black	4-11/16"		L-18-120-0-L				TY5275MX	PLT5H-LO
24-175-N	24" x 175 lb.	Natural	7"	1.9	L-24-175-9-L		10612	WIT-175R	TY5277M	PLT7LH-L
24-175-UV	24" x 175 lb.	UV Black	7"		L-24-175-0-L		10614	WIT-175RUVB	TY5277MX	PLT7LH-LO

Example Stock Codes: 4-18-NC = 100 piece bags, 4-18-NM = 1000 piece bags, 18-175-NL = 50 piece bags



Mechanical Properties of Steel - Condition, Strength, Hardness, Machinability

Stainless Steels

AISI	Materials Condition	Tensile Strength ksi	Yield Strength ksi	Hardness		Machinability % of CD1212	Permeability	
				Brinell	Rockwell		Annealed	Drawn
Type 302 HQ	Annealed Bars	75 - 95	35 - 55	150 - 180	80 - 90B	60	Non-magnetic	Non-magnetic to slightly magnetic
Type 303	Annealed Bars	85 - 95	30 - 40	160 - 180	83 - 95B	73	Non-magnetic	Magnetic
Type 304	Annealed Bars	80 - 90	30 - 40	150 - 180	80 - 90B	45	Non-magnetic	Slightly magnetic
Type 316	Annealed Bars	75 - 90	30 - 40	150 - 180	80 - 90B	40	Non-magnetic	Non-magnetic to slightly magnetic
Type 410	Annealed Bars	70 - 100	35 - 45	150 - 200	80 - 90B	55	Magnetic	Magnetic
Type 416	Annealed Bars	80 - 100	55 - 65	190 - 220	90 - 95B	90	Magnetic	Magnetic
Type 17-4	Bars Cond. A	150	110	320	35C	45	Magnetic	Magnetic
	Cond. H 900	200	185	415	44C			
	Cond. H 1025	170	165	352	38C			

Carbon Steels - Rephosphorized & Resulphurized

Grade	Type of Processing	Estimated Minimum Values		Brinell Hardness	Average Machinability Rating (Cold Drawn 1212-100%)
		Tensile Strength psi	Yield Strength psi		
1006	Hot rolled	43,000	24,000	86	50
	Cold drawn	48,000	41,000	95	
1008	Hot rolled	44,000	24,500	86	55
	Cold drawn	49,000	41,500	95	
1010	Hot rolled	47,000	26,000	95	55
	Cold drawn	53,000	44,000	105	
1018	Hot rolled	58,000	32,000	116	70
	Cold drawn	64,000	54,000	126	
1022	Hot rolled	62,000	34,000	121	70
	Cold drawn	69,000	58,000	137	
1038	Hot rolled	75,000	41,000	149	65
	Cold drawn	83,000	70,000	163	
1045	Hot rolled	82,000	45,000	163	55
	Cold drawn	91,000	77,000	179	
	ACD*	85,000	73,000	170	
1212	Hot rolled	56,000	33,500	121	100
	Cold drawn	78,000	60,000	167	
12L14	Hot rolled	57,000	34,000	121	160
	Cold drawn	78,000	60,000	163	
1215	Hot rolled	57,000	34,000	121	135
	Cold drawn	75,000	65,000	163	
1117	Hot rolled	62,000	34,000	121	90
	Cold drawn	69,000	58,000	137	
1141	Hot rolled	94,000	51,500	187	70
	Cold drawn	105,100	88,000	212	
1144	Hot rolled	97,000	53,000	197	80
	Cold drawn	108,000	90,000	217	

* ACD: annealed, cold drawn

All SAE 1100 series steels are rated on the basis for 0.10 max silicon or coarse grain melting practice. The mechanical properties shown are expected minimums for the sizes ranging from 3/4" to 1-1/4". REF: SAE J1397 Rev. May 1992

Alloy Steels

SAE No.	Machinability Rating	Condition	Range of Typical Hardness (Brinell)
4037	70	Annealed & Cold Drawn	174-217
8620	65	Hot Rolled & Cold Drawn	179-235
8630	70	Annealed & Cold Drawn	179-229
4130	70	Annealed & Cold Drawn	187-229
4140	65	Annealed & Cold Drawn	187-229

Approximate Hardness Conversions For Steel

Tensile Strength (Approx.) ksi	Rockwell Hardness No.		Brinell Hardness No.
	B Scale	C Scale	
56	65.7	-	111
60	69.8	-	121
65	74.0	-	131
71	78.7	-	143
76	82.9	-	156
81	86.0	-	167
85	87.8	-	174
90	90.7	-	187
95	92.8	-	197
100	94.6	-	207
105	96.4	-	217
110	97.8	20	226
114	99.0	22	237
117	100.0	23	243
120	-	24	247
122	-	25	253
125	-	26	258
128	-	27	264
132	-	28	271
135	-	29	279
138	-	30	286
142	-	31	294
145	-	32	301
149	-	33	311
153	-	34	319
157	-	35	327
162	-	36	336
168	-	37	344
171	-	38	353
176	-	39	362
181	-	40	371
188	-	41	381
194	-	42	390
201	-	43	400
208	-	44	409
215	-	45	421
222	-	46	432

The technical material presented in this appendix is for general reference only. Every attempt has been made to ensure the accuracy thereof; however, Pivot Point does not warrant in any way the accuracy or completeness of the information presented. It is the sole responsibility of the user to determine material and design suitability for their specific application.



Get quote >>



Angic Global Solutions

1-888-872-0690

<https://www.AngicGlobal.com> Sales@AngicGlobal.com

Chemical Composition - Steels, Alloys and Stainless - Ranges and Limits (Percent)

Grade	C	Mn	P Max.	S Max.	Si Max.	Ni	Cr	Mo Max.	Other Elements
Standard Carbon Steels									
1006	.08 max.	.25 - .40	0.04	0.05					
1008	.10 max.	.30 - .50	0.04	0.05					
1010	.08 - .13	.30 - .60	0.04	0.05					
1018	.15 - .20	.60 - .90	0.04	0.05					
1022	.18 - .23	.70 - 1.00	0.04	0.05					
1038	.35 - .42	.60 - .90	0.04	0.05					
1045	.43 - .50	.60 - .90	0.04	0.05					
Rephosphorized & Resulphurized Carbon Steels									
1117	.14 - .20	1.00 - 1.30	0.04	.08 - .13					
1141	.37 - .45	1.35 - 1.65	0.04	.08 - .13					
1144	.40 - .48	1.35 - 1.65	0.04	.24 - .33					
12L14	.15 - max.	.85 - 1.15	.04 - .09	.26 - .35					Pb (.15 - .35)
1215	.09 - max.	.75 - 1.05	.04 - .09	.26 - .35					
Standard Alloy Steels									
4037	.35 - .40	.70 - .90	0.035	0.04	.20 - .35			.20 - .30	
8620	.18 - .23	.70 - .90	0.035	0.04	.20 - .35	.40 - .70	.40 - .60	.15 - .25	
8630	.28 - .33	.70 - .90	0.035	0.04	.20 - .35	.40 - .70	.40 - .60	.15 - .25	
4130	.28 - .33	.40 - .60	0.035	0.04	.20 - .35		.80 - 1.10	.15 - .25	
4340	.38 - .43	.75 - 1.00	0.035	0.04	.20 - .35		.80 - 1.10	.15 - .25	
Stainless Steel - Austenitic/Non-Magnetic (May Be Slightly Magnetic)									
302HQ	.10 max.	2.00 max.	0.045	0.03	1.00	8.00 - 10.00	17.00 - 19.00		
302	.15 max.	2.00 max.	0.045	0.03	1.00	8.00 - 10.00	17.00 - 19.00		
303	.15 max.	2.00 max.	0.200	.15 min.	1.00	8.00 - 10.00	17.00 - 19.00	0.60	
304	.08 max.	2.00 max.	0.045	0.03	1.00	8.00 - 10.50	18.00 - 20.00		
316	.08 max.	2.00 max.	0.045	0.03	1.00	10.00 - 14.00	16.00 - 18.00	2.00 - 3.00	
Stainless Steel - Martensitic/Magnetic									
410	0.15	1.00	0.04	0.03	1.00		11.50 - 13.50		
420	.15 min.	1.00	0.04	0.03	1.00		12.00 - 14.00		
Stainless Steel - Precipitation Hardening Alloy									
17-4PH	0.07	1.00	0.04	0.03	1.00	3.00 - 5.00	15.50 - 17.50		Co + Ta (.15-.45)

Fastener Plating & Finishes

Finish	Color	For Use On (material)	Corrosion Resistance	Characteristics
Zinc (electroplated)	White to blue grey	All Metals	Good	Most common used plating. Good rust-resisting qualities, appearance and low cost.
Cadmium (electroplated)	Bright or dull silver grey	All Metals	Excellent	Superior rust-resisting qualities used in marine and aviation applications. Relatively high cost and toxic to the environment.
Chromate	Yellow, olive drab, black, blue/white	Zinc & Cadmium Plated Parts	Very Good	A secondary dipping process after plating increasing corrosion resistance, adding color or brilliance.
Black Oxide	Black	Ferrous Metals & Stainless Steel	Fair	A chemical discoloration which does not add to part thickness. Usually combined with an oil dip. Rust resistance comes from the oil only.
Phosphate & Oil	Charcoal grey or black	Steel	Good	Zinc or manganese phosphate used with a rust-inhibiting oil dip. Low cost.
Iridite	Olive drab, green, black, red, blue, bronze	All Metals	Good	Applied on top of zinc or cadmium plating as a die for color and additional corrosion protection.
Nickel	Silver	All Metals	Very Good	Hard stable finish, relatively expensive and sometimes hard to apply.
Chromium	Bright blue/white	All Metals	Very Good	Hard lustrous finish adds wear resistance and is very expensive.
Hot Dip Zinc (galvanizing)	Dull grey	All Metals	Very Good	Parts are dipped in pure zinc. Gives maximum corrosion protection. Adds a thick irregular coating. Size must be adjusted to allow for thickness of coat.
Passivating	Bright - etched	Stainless Steel	Excellent	Parts are dipped in nitric acid which removes iron particles and brightens the finish. Produces a passive corrosion-resistant finish.
Anodizing	Frosty - etched	Aluminum	Excellent	Acid dip produces a hard oxide surface. Can be color dipped after anodizing for preferred finish.

Fastener Steels

Alloy Steels: Steels alloyed with molybdenum, nickel and chromium (AISI 4037, 4130, 8630) are best where high strength is required. These steels have good cold forming properties in the annealed condition and can be heat-treated for the best combination of strength, toughness and shock resistance.

Aluminum Alloys: Good cold-forming characteristics. Many aluminums can be used (2024, 3003, 5056, 5554, 6061, and 7075), and where secondary machining is required (2011). Aluminum is corrosion resistant and some can be heat-treated.

Carbon Steels: Fine grain, fully-killed basic steel with no alloying agent.
Low Carbon Steels: Range from .06-.22% carbon content (AISI 1008, 1018) and have good ductility for cold forming.

Medium Carbon Steels: Have .30-.50% carbon content (AISI 1038, 1045). Stronger and less ductile, these steels respond well to quench and temper.

High Carbon Steels: .50% carbon and up (AISI 1066, 1095). Difficult to cold form unless annealed. High strength, can be heat-treated.

Hard Drawn MB Spring Wire, ASTM A227: Carbon range .60-.70%. Used for general purpose low-cost springs. Commonly available in diameters .031 to .500. Lower tensile strength than music wire.

Leaded Steels: Lead added to steel improves machinability. Identified by an "L" (AISI 12L14) in the AISI/SAE designation. This is most commonly added to 1100 and 1200 series 'screw machine' steels. Leaded steels are not suitable for heat treatment or welding.

Music Wire, ASTM A228: Carbon range .80-.95%. High tensile strength can withstand repeated loading. Widely used in small diameter rounds .005 to .125.

Resulphurized and Re-phosphorized Steels (AISI 1117 and 1215): Improved machinability over basic carbon steels. Used commonly for screw machine parts, they are more brittle, less ductile and stronger than equivalent carbon content basic steel. Sulphur acts as an internal lubricant and is the major alloying agent for "1100" series steels. Phosphorus makes the steel more brittle, reducing friction, heat and tool wear. "1200" series steels have both phosphorous and sulphur as alloys.

Stainless Steels

Austenitic Stainless Steels: (AISI 202, 302, 304, 316) Generally nonmagnetic and the best corrosion resistant due to their large content of nickel and chromium. Good cold-forming characteristics are subject to work hardening and are not heat treatable.

Martensitic Stainless Steel: Straight chromium steel with little or no nickel (AISI 410, 420). These steels are magnetic and can be heat-treated. Higher strength than austenitic types, lower corrosion resistance and harder to cold form.

Precipitation Hardening Stainless: (AISI 17-4 PH) Nickel chromium stainless with cobalt and tantalum. The alloying agents produce high strength and ductility, good machinability and weldability. Hardening is by aging the cold steel at 900° F for 4 hours followed by air-cooling. Not used for cold forming but commonly used for high-strength, corrosion resistant screw machine parts.

AISI-SAE Index System for Carbon and Alloy Steels

Type of Steel	Series Designation
Carbon Steels	1XXX
Plain Carbon	10XX
Free machining, resulphurized (screw stock)	11XX
Free machining, resulphurized rephosphorized	12XX
Manganese Steels	13XX
High Manganese Carburizing Steels	15XX
Nickel Steels	2XXX
3.5% nickel	23XX
5.0% nickel	25XX
Nickel-Chromium Steels	3XXX
1.25% Nickel, 0.60 % Chromium	31XX
1.75% Nickel, 1% Chromium	32XX
3.5% Nickel, 1.5% Chromium	33XX
Corrosion and Heat Resisting Steels	30XXX
Molybdenum Steels	4XXX
Carbon-Molybdenum	40XX
Chromium-Molybdenum	41XX
Chromium-Nickel-Molybdenum	43XX
Nickel-Molybdenum	45XX and 48XX

Type of Steel	Series Designation
Chromium Steels	5XXX
Low Chromium	51XX
Medium Chromium	52XXX
Corrosion and Heat Resisting	51XXX
Chromium-Vanadium Steels	6XXX
Chromium 1.0%	61XX
Nickel-Chromium-Molybdenum	86XX and 87XX
Manganese-Silicon	92XX
Nickel-Chromium-Molybdenum	93XX
Manganese-Nickel-Chromium-Molybdenum	94XX
Nickel-Chromium-Molybdenum	97XX
Nickel-Chromium-Molybdenum	98XX
Boron (0.0005% Boron minimum)	XXBXX

Alloying Elements in Steel

Alloying Element	Symbol
Aluminum	Al
Carbon	C
Chromium	Cr
Cobalt	Co
Copper	Cu
Manganese	Mn
Molybdenum	Mo
Nickel	Ni
Phosphorus	P
Silicon	Si
Tungsten	W
Vanadium	V

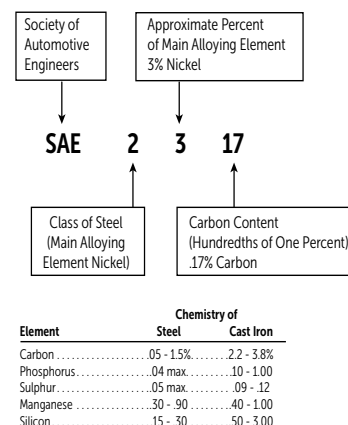

Mechanical Definitions

Cold Working: Deformation of a metal at room temperature without fracture which changes its shape and produces higher tensile strength and machinability.

Ductility: The ability of a metal to be deformed extensively under tension load without rupture or fracture. Ductility is expressed in terms of percent elongation and percent reduction of area (e.g. drawn into wire).

Machinability: The condition or property of a metal which allows it to be cut, turned, broached or formed by machine tools.

Malleability: The ability of a metal to be deformed permanently under compression load without rupture or fracture (e.g. hammer or rolled into sheets).

Tensile Strength: The maximum load in tension (pulling apart or shearing) which a material can withstand before breaking or fracturing. Also known as the ultimate tensile strength (UTS) or maximum strength.

Work Hardening: Hardening that takes place through grain alignment when a metal is bent, rolled or hammered at room temperature. Not all metals work harden.

Yield Strength: The maximum load which a material exhibits a specific permanent deformation. Deformation to determine yield varies with material.

Process Definitions

Alloy Steel: A carbon steel to which one or more elements are added to add special properties for a specific use.

Billet: A cast section of steel 4 to 6 inches square about 20 ft. long from which dimensional shapes of steel are rolled.

Brass: An alloy of copper and zinc which can contain small amounts of aluminum, iron, manganese, or tin to produce specific properties.

Bronze: An alloy of copper and tin or an alloy of aluminum and silicon.

Carbon Steel: A steel in which carbon is the only alloying element added to iron.

Killed Steels: Molten steel treated with aluminum, silicon, or manganese until no more gas is in the metal and it is in a quiet state.

Pickling: The removal of oxide scale from metal by dipping it in a diluted acid bath. The chemically clean surface is then ready for cold rolling or wire drawing.

Rockwell Hardness Test: A method of determining metal hardness by indenting with a metal ball or diamond cone under a specified load.

Heat Treating Definitions

Annealing: Heating and slow cooling to remove stresses, make steel softer, refine the structure, or change its ductility.

Carburizing: Adding carbon to the surface of iron-based alloys by heating the metal below its melting point in contact with carbon-rich solids, liquids or gasses.

Case Hardening: Carburizing a metal surface followed by quenching to fix a hard outer case high in carbon combined with a relatively soft middle or core.

Cyanide Hardening: A method of case hardening which brings the metal surface in contact with the molten cyanide salt followed by quenching.

Decarburization: Removal of carbon from the surface of steel. This can occur through normal oxidizing action or as the result of heat treatment.

Drawing (Tempering): Reheating after hardening, held at a specific temperature and then quenched. This reduces hardness and increases toughness.

Hydrogen Embrittlement: A condition where the surface finishing of metal (plating) results in a brittle outer case due to immersion in acid. Baking immediately following the plating process removes this brittle surface condition.

Nitriding: A hardening process which adds nitrogen to a metal surface through contact with ammonia gas. Produces surface hardness (case) without quenching.

Precipitation Hardening: A hardening process where certain metals are held at elevated temperature without quenching (age hardening).

Quenching: Rapid cooling of steel by immersion in oil or water to fix its structure in a hardened state.

Spheroidizing (anneal): Any process of heating and cooling steel that produces a rounded or globular form of carbide. This softens the metal, improving ductility.

Stress Relieve: A low temperature heat treatment, which removes stresses caused by cold working.

Clevis Pin Definitions

Length: Refers to length under head to end of pin.

Effective Length: Length under head to the edge of the hole closest to the head. Also known as grip length.

Overall Length: Total length of the pin from the top of the head to the opposite end.



Get quote >>



Angic Global Solutions

1-888-872-0690

<https://www.AngicGlobal.com> Sales@AngicGlobal.com