

PennEngineering®

# PEM® FASTENER CATALOG

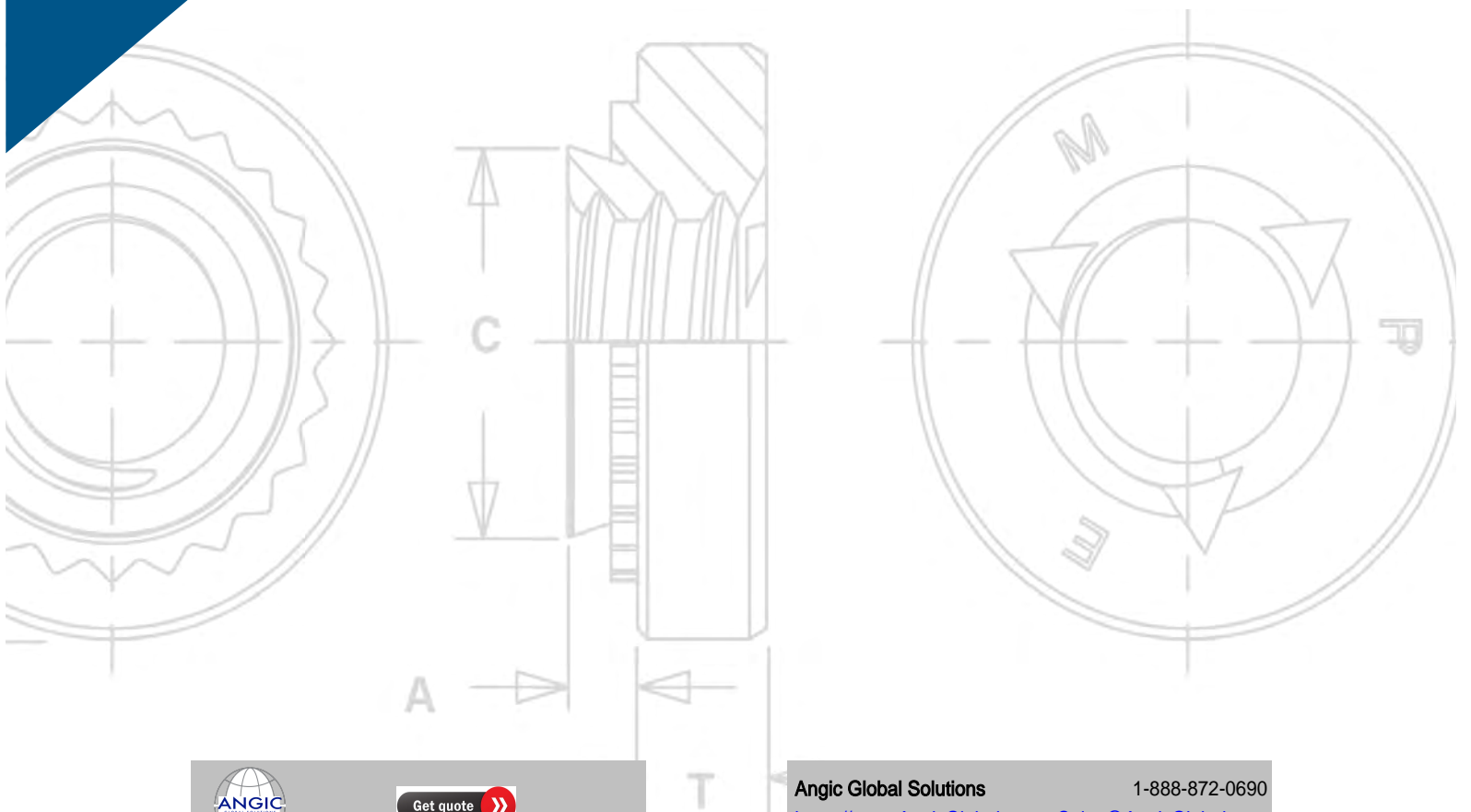

Get quote >>

Angic Global Solutions

1-888-872-0690

<https://www.AngicGlobal.com> [Sales@AngicGlobal.com](mailto:Sales@AngicGlobal.com)

## TABLE OF CONTENTS

Quick Product Locator .....	Pg <a href="#">3</a>
Floating Self-Clinching Fasteners .....	Pg <a href="#">11</a>
Self-Clinching Blind Fasteners.....	Pg <a href="#">15</a>
Concealed-Head Self-Clinching Studs and Standoffs.....	Pg <a href="#">19</a>
Self-Clinching Nuts.....	Pg <a href="#">25</a>
PEMSERT® Self-Clinching Fasteners.....	Pg <a href="#">41</a>
Miniature Self-Clinching Fasteners .....	Pg <a href="#">45</a>
Self-Clinching Studs and Pins.....	Pg <a href="#">51</a>
Fasteners for Use with P.C. Boards.....	Pg <a href="#">83</a>
Self-Locking Fasteners .....	Pg <a href="#">104</a>
microPEM® Fasteners .....	Pg <a href="#">127</a>
Captive Panel Screws.....	Pg <a href="#">145</a>
R'ANGLE® Right Angle Fasteners .....	Pg <a href="#">188</a>
SPOTFAST® Fasteners .....	Pg <a href="#">196</a>
Self-Clinching KEYHOLE® Fasteners.....	Pg <a href="#">204</a>
Self-Clinching Standoffs .....	Pg <a href="#">216</a>
Fasteners for Use in Stainless Steel Sheets.....	Pg <a href="#">228</a>
SNAP-TOP® Standoffs .....	Pg <a href="#">252</a>
Self-Clinching TY-D® Cable Tie-Mounts and Hooks.....	Pg <a href="#">259</a>
VARIMOUNT® Bonding Fasteners .....	Pg <a href="#">265</a>
Self-Locating Projection Weld Nuts.....	Pg <a href="#">271</a>



PEM® brand fasteners utilize self-clinching, broaching, flaring, surface mount, bonding or weld technology to provide strong, reusable, and permanent threads and mounting points in thin sheet metal, P.C. board or other rigid materials.



# INDEX

## QUICK PRODUCT LOCATOR

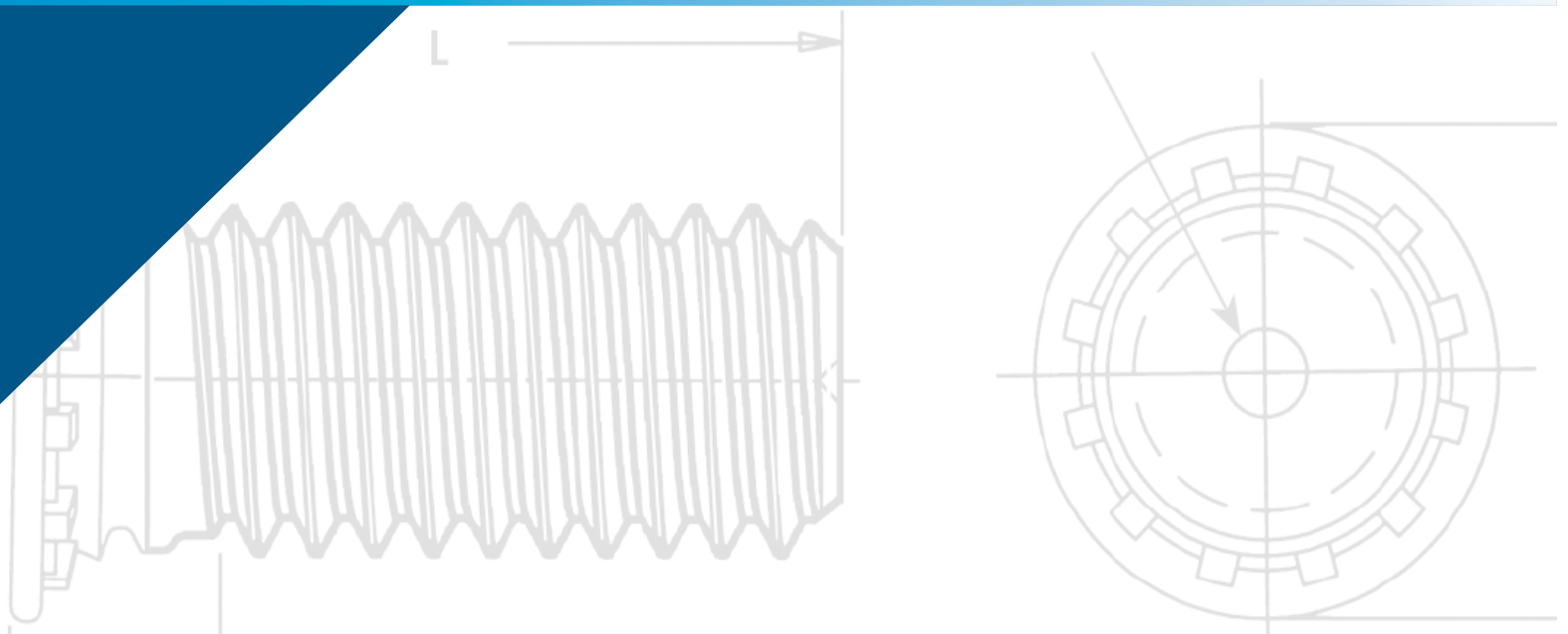

Get quote »

Angic Global Solutions

1-888-872-0690

<https://www.AngicGlobal.com> [Sales@AngicGlobal.com](mailto:Sales@AngicGlobal.com)

# PEM® FASTENER IDENTIFICATION MARKS

To help you identify genuine PEM® brand fasteners, most are marked by one of our trademarks or identifiers. Genuine PEM fasteners can only be purchased from one of our authorized worldwide distributors. For a complete listing of these distributors, check our web site: [www.pemnet.com](http://www.pemnet.com).

## Trademark PEM® Dimple



CFHA, CFHC, CHA, CHC, FH, FH4, FHA, FHL, FHLS, FHP, FHS, FHX, HF109, HFG8, HFE, HFH, HFHB, HFHS, HFLH, HSCB, KFH, KSSB, MPP, PF10, PF30, PF31, PF32, PF50, PF51, PF52, PF60, PF61, PF62, PF11, PF11M, PF11MF, PF11MW, PF11PM, PF12, PF12M, PF12MF, PF12MW, PF7M, PF7MF, PFC2, PFC2P, PFC4, PFHV, PFK, PFS2, PSHP, SCB, SCBJ, SCBR, SF, SFK, SFP, SFW, SGPC, SKC, SKC-F, SMTPLSM, SMTSS, SMTSK SSA, SSC, SSS, T, T4, TFH, TFHS, THFE, TK4, TKA, TP4, TPS, TPXS, and TS fasteners

## Trademark PEM® Stamp

CLS, CLSS, H, HN, HNL, PSHP, S, SFN, SL, SMPP, SMPS, SS, and WN fasteners



## Trademark PEM® Skirted Shoulder

PF11, PF11M, PF11MF, PF11MW, PF11PM, PF12, PF12M, PF12MF, PF12MW, PF7M, and PF7MF fasteners



## Trademark PEM® "Single Groove"

A4, BSO4, LA4, MSO4, PFC4, SO4, SP (Select sizes), and TSO4 fasteners

## Trademark PEM® "Two Groove"

B, BS, BSO, BSON, BSOS, CSOS, CSS, DSO, DSOS, HSR, KF2, KFB3, KFE, KFS2, KFSE, PF7M, PF7MF, SMTSO, SMTSOB, SMTPLSM, SO, SOA, SOAG, SON, SOS, SOSG, TSO, TSOA, and TSOS fasteners



## Trademark PEM® "Double Squares"

A4, AC, AS, LA4, LAC, and LAS fasteners



Trademark PEM® C.A.P.S.® Dot Pattern PF11PM fastener

Trademark PEM® Circle on Pedestal RAS fastener



Trademark PEM® Double Notch microPEM® SMTSO fastener

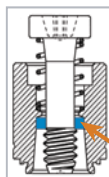

PEM® Blue Nylon Ring PFC4, PFC2P, PFC2, PFS2, and PFK fasteners

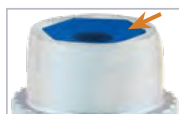

Trademark PEM® Blue Nylon Locking Element PL, PLC and CFN fasteners



Trademark ATLAS® AE Stamp MaxTite® and Plus+Tite® products

## Trademark PEM VM® Stamp

(Both Sides) VariMount™ Base Plates

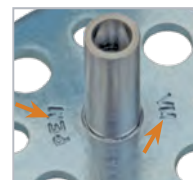

Trademark PEM® SH Stamp SH fasteners



PEM® RT Stamp S-RT fasteners



Trademark PEM® SP Stamp SP fasteners



PEM® SMPP Stamp SMPP fasteners



Get quote »

Angic Global Solutions

1-888-872-0690 [www.pemnet.com](http://www.pemnet.com) 4

<https://www.AngicGlobal.com> Sales@AngicGlobal.com

**SC Self-clinching** fasteners are pressed into sheet metal panels as thin as .016" / 0.4 mm.



**FM Flare Mounted** fasteners can be installed into almost any rigid type of panel.



**B Broaching** fasteners are pressed into P.C. board or other plastic materials as thin as .060" / 1.53 mm.



**W Weld nuts** are designed specially to be welded into place.



**SM Surface Mounted** fasteners on tape and reel are soldered to a PC board in the same way as other surface mount components.



*(Products are listed alphabetically by type. Refer to matching color square for mounting style)*

**A4, AC, AS** Bulletin ALA

 Nuts with load-bearing, non-locking threads that permits up to .030"/0.76mm adjustment for mating hole misalignment. SC

**F, F4** Bulletin F

 PEMSERT® flush fasteners are flush with both sides of the sheet. SC

**B, BS** Bulletin B

 Nuts used in applications requiring closed thread ends. Blind end limits screw penetration and excludes foreign matter. SC

**FE, FEO, FEOX, FEX** Bulletin FE

 Miniature nuts with strong threads. Available with locking or non-locking threads. SC

**BS0, BS04, BS0A, BS0S** Bulletin S0

 Blind threaded standoffs installed with their heads flush with one surface of the mounting sheets. SC

**FH, FH4, FHA, FHP, FHS** Bulletin FH

 Flush-head studs with high pushout and torque-out resistances. SC

**CDS** Bulletin MPF

 The microPEM® ClampDisk™ fastener is a removable fastener designed to replace screws, adhesive, rivets and other small fasteners.

**FHL, FHLS** Bulletin FH

 Low-displacement head studs can be installed close to the edge of a sheet without causing the edge to bulge. SC

**CFN** Bulletin LN

 Broaching, nylon insert, self-locking nuts for use in thinner sheet, close-to-edge applications. B

**FHX** Bulletin FH

 Flush-head studs with X-Press™ thread profile are typically used with push-on or other plastic fasteners. SC

**CFHA, CFHC, CHA, CHC** Bulletin CH

 Concealed-head studs installed into a blind milled hole where surface opposite stud must remain unmarred. SC

**H, HNL** Bulletin CL

 Nuts with self-locking or non-locking threads that provide high pushout and torque-out resistances. SC

**CLA, CLS, CLSS** Bulletin CL

 Nuts that provide load-bearing threads in thin sheets with high pushout and torque-out resistances. SC

**HF109** Bulletin FH

 Property class 10.9 high tensile strength studs meeting 1040 MPa minimum. SC

**CSOS, CSS** Bulletin CH

 Concealed-head standoffs installed into a blind milled hole where surface opposite standoff must remain unmarred. SC

**HFE** Bulletin FH

 Studs designed with an enlarged head diameter to provide high-strength in thin sheets. SC

**DS0, DS0S** Bulletin S0

 Threaded standoffs for use in close-to-edge applications. SC

**HFG8** Bulletin FH

 Grade 8 high tensile strength studs meeting 150 ksi minimum. SC





























Get quote »

Angic Global Solutions

1-888-872-0690 [www.angic.com](http://www.angic.com) 5

<https://www.AngicGlobal.com> [Sales@AngicGlobal.com](mailto:Sales@AngicGlobal.com)

<b>HFH, HFHB, HFHS</b>	<b>Bulletin FH</b>
	Studs for high-strength applications with high pull through resistance. <span style="float: right;">SC</span>
<b>HFLH</b>	<b>Bulletin FH</b>
	Studs are for installation into thin, harder, high-strength materials. <span style="float: right;">SC</span>
<b>HSCB</b>	<b>Bulletin PF</b>
	Heat sink mounting system. HSCB (screw), HSR (nut) and HSL (spring). <span style="float: right;">SC B</span>
<b>KF2, KFS2</b>	<b>Bulletin K</b>
	Nuts, internally threaded, for mounting on P.C. boards. <span style="float: right;">B</span>
<b>KFB3</b>	<b>Bulletin K</b>
	Flare-mounted standoffs for mounting on P.C. boards with greater pullout performance. <span style="float: right;">B</span>
<b>KFE, KFSE</b>	<b>Bulletin K</b>
	Threaded or unthreaded standoffs mounted on P.C. boards for stacking or spacing. <span style="float: right;">B</span>
<b>KFH</b>	<b>Bulletin K</b>
	Threaded studs for use as solderable connectors or as permanently mounted studs on P.C. boards. <span style="float: right;">B</span>
<b>KSSB</b>	<b>Bulletins K &amp; SSA</b>
	SNAP-TOP® standoffs featuring a spring action to hold a P.C. Board securely without screws or threaded hardware. <span style="float: right;">SC</span>
<b>LA4, LAC, LAS</b>	<b>Bulletins ALA &amp; LN</b>
	Nuts with load-bearing, self-locking threads that permits up to .030" / 0.76 mm adjustment for mating hole misalignment. <span style="float: right;">SC</span>
<b>LK, LKA, LKS</b>	<b>Bulletin LN</b>
	Nuts with a unique PEMFLEX® self-locking feature permitting repeated use and effective prevailing locking torque. <span style="float: right;">SC</span>
<b>MPP</b>	<b>Bulletin MPF</b>
	microPEM® pins that can be installed into sheets as thin as 0.5 mm. <span style="float: right;">SC</span>
<b>MSIB</b>	<b>Bulletin MPF</b>
	microPEM® symmetrical designed thru-threaded inserts for plastics for use in straight or tapered holes. <span style="float: right;">Inserts</span>
<b>MSO4</b>	<b>Bulletin MPF</b>
	microPEM® standoffs that can be installed into sheets as thin as .016" / 0.4 mm. <span style="float: right;">SC</span>

<b>MSOFS</b>	<b>Bulletin MPF</b>
	microPEM® flaring standoffs attached permanently in panels as thin as .008" / 0.2 mm of any hardness including stainless steel. <span style="float: right;">FM</span>
<b>PEM C.A.P.S.®</b>	<b>Bulletin PF</b>
	Colored Access Panel Screws with plastic cap. Key features include Phillips drive and MAThread® anti-cross threading feature. <span style="float: right;">SC FM</span>
<b>PF10</b>	<b>Bulletin PF</b>
	Flush-mounted panel screw components. N10 (nut), PR10 (retainer) and PS10 (screw). <span style="float: right;">SC</span>
<b>PF11, PF11M</b>	<b>Bulletin PF</b>
	Panel fastener assembly with knurled cap and universal slot/Phillips recess. Available with anti cross-thread feature. <span style="float: right;">SC</span>
<b>PF11MF</b>	<b>Bulletin PF</b>
	Flare-mounted captive screw assembly with anti cross-thread feature. <span style="float: right;">FM</span>
<b>PF11MW</b>	<b>Bulletin PF</b>
	Floating captive screw assembly allows for mating hole misalignment. <span style="float: right;">FM</span>
<b>PF12, PF12M</b>	<b>Bulletin PF</b>
	Panel fastener assembly with smooth cap and universal slot/Phillips recess. Available with anti cross-thread feature. <span style="float: right;">SC</span>
<b>PF12MF</b>	<b>Bulletin PF</b>
	Flare-mounted captive screw assembly with anti cross-thread feature. <span style="float: right;">FM</span>
<b>PF12MW</b>	<b>Bulletin PF</b>
	Floating captive screw assembly allows for mating hole misalignment. <span style="float: right;">FM</span>
<b>PF30, PF31, PF32</b>	<b>Bulletin PF</b>
	Low-profile panel fastener assembly with large knurled head for tool or hand operation. <span style="float: right;">SC</span>
<b>PF50</b>	<b>Bulletin PF</b>
	Low-profile panel fastener assembly with large knurled cap and Phillips recess for tool or hand operation. <span style="float: right;">SC</span>
<b>PF60</b>	<b>Bulletin PF</b>
	Low-profile panel fastener assembly with large smooth cap and Phillips recess for tool or hand operation. <span style="float: right;">SC</span>
<b>PF7M</b>	<b>Bulletin PF</b>
	Small, compact, and low-profile self-clinching captive panel screws designed for limited access areas. <span style="float: right;">SC</span>

<b>PF7MF</b> <span style="float: right;">Bulletin PF</span>  <p>Small, compact, and low-profile flaring captive panel screws designed for limited access areas.</p> <p style="text-align: right;"><b>FM</b></p>	<b>SCB</b> <span style="float: right;">Bulletin PF</span>  <p>The spinning clinch bolt with axial float installs captive in panel and still spins freely.</p> <p style="text-align: right;"><b>SC</b></p>
<b>PFC2, PFS2</b> <span style="float: right;">Bulletin PF</span>  <p>Spring-loaded panel fastener assembly for tool or hand operation.</p> <p style="text-align: right;"><b>SC</b></p>	<b>SCBJ</b> <span style="float: right;">Bulletin PF</span>  <p>The spinning clinch bolt with jacking feature installs captive in panel and still spins freely.</p> <p style="text-align: right;"><b>SC</b></p>
<b>PFC2P</b> <span style="float: right;">Bulletin PF</span>  <p>Panel fastener assembly with Phillips recess for tool only operation.</p> <p style="text-align: right;"><b>SC</b></p>	<b>SCBR</b> <span style="float: right;">Bulletin PF</span>  <p>The spinning clinch bolt with axial float utilizes self-retracting spring.</p> <p style="text-align: right;"><b>SC</b></p>
<b>PFC4</b> <span style="float: right;">Bulletin PF &amp; SS</span>  <p>Panel fastener assembly for installation into stainless steel sheets with Phillips recess for tool only operation.</p> <p style="text-align: right;"><b>SC</b></p>	<b>SF, SFP</b> <span style="float: right;">Bulletin SF</span>  <p>SpotFast® self-clinching fasteners create a permanent, flush joining of two sheets of metal.</p> <p style="text-align: right;"><b>SC</b></p>
<b>PFHV</b> <span style="float: right;">Bulletin PF</span>  <p>Low-cost panel fastener assembly with universal slot/Phillips recess for tool or hand operation.</p> <p style="text-align: right;"><b>SC</b></p>	<b>SFK</b> <span style="float: right;">Bulletin SF</span>  <p>SpotFast® self-clinching fasteners create a permanent, flush joining of metal to PCB or plastic panels.</p> <p style="text-align: right;"><b>SC B</b></p>
<b>PFK</b> <span style="float: right;">Bulletins K &amp; PF</span>  <p>Panel fastener assembly for mounting on P.C. boards.</p> <p style="text-align: right;"><b>B</b></p>	<b>SFN</b> <span style="float: right;">Bulletin SFN</span>  <p>Spinning flare nut is a one-piece, flanged hex nut that is permanently captive and still spins freely in the sheet.</p> <p style="text-align: right;"><b>FM</b></p>
<b>PL, PLC</b> <span style="float: right;">Bulletin LN</span>  <p>PEMHEX® self-locking nuts with a nylon hexagonal element to provide a reusable prevailing torque thread lock.</p> <p style="text-align: right;"><b>SC</b></p>	<b>SH</b> <span style="float: right;">Bulletin CL</span>  <p>Nuts are for installation into thin, harder, high-strength materials.</p> <p style="text-align: right;"><b>SC</b></p>
<b>PSHP</b> <span style="float: right;">Bulletin K</span>  <p>Surface mount panel fastener screw that is used with Type SMTPR retainer.</p> <p style="text-align: right;"><b>SM</b></p>	<b>SFW</b> <span style="float: right;">Bulletin SF</span>  <p>SpotFast® self-clinching fasteners create a permanent, flush joining of two sheets of metal. The washer allows for consistent pivoting of the two metal panels.</p> <p style="text-align: right;"><b>SC</b></p>
<b>PSL2, PTL2</b> <span style="float: right;">Bulletin PF</span>  <p>Spring-loaded plunger assembly. Quick lockout feature on Type PTL2 holds plunger in retracted position.</p> <p style="text-align: right;"><b>SC</b></p>	<b>SGPC</b> <span style="float: right;">Bulletin FH</span>  <p>Install into most panel material, provide strong torque-out resistance and are suitable for close centerline-to-edge situations.</p> <p style="text-align: right;"><b>FM</b></p>
<b>RAA</b> <span style="float: right;">Bulletin RA</span>  <p>Self-tapping R'ANGLE® fasteners provide strong right angle attachment points in thin sheets.</p> <p style="text-align: right;"><b>SC</b></p>	<b>SKC</b> <span style="float: right;">Bulletin SK</span>  <p>KEYHOLE® standoffs designed for a board to be quickly slipped into place and removed by sliding it sideways and lifting it off.</p> <p style="text-align: right;"><b>SC</b></p>
<b>RAS</b> <span style="float: right;">Bulletin RA</span>  <p>Threaded R'ANGLE® fasteners provide strong right angle attachment points in thin sheets.</p> <p style="text-align: right;"><b>SC</b></p>	<b>SKC-F</b> <span style="float: right;">Bulletin SK</span>  <p>KEYHOLE® sheet joining fasteners designed to quickly join two sheets flat against each other and then can be removed.</p> <p style="text-align: right;"><b>SC</b></p>
<b>S, SS</b> <span style="float: right;">Bulletin CL</span>  <p>Nuts that provide load-bearing threads in thin sheets with high pushout and torque-out resistances.</p> <p style="text-align: right;"><b>SC</b></p>	<b>SL</b> <span style="float: right;">Bulletins CL &amp; LN</span>  <p>Locknuts designed with a unique TRI-DENT® locking feature, which meets demanding locking performance requirements.</p> <p style="text-align: right;"><b>SC</b></p>
<b>S-RT</b> <span style="float: right;">Bulletin CL</span>  <p>Free-running locknuts with a thread form that creates a lock when clamp load is applied.</p> <p style="text-align: right;"><b>SC</b></p>	<b>SMPS, SMPP</b> <span style="float: right;">Bulletin CL</span>  <p>Nuts that feature a lower profile and can be mounted closer to the edge of a sheet than standard self-clinching nuts.</p> <p style="text-align: right;"><b>SC</b></p>

























Get quote >>

Angic Global Solutions

1-888-872-0690 [met.com 7](https://www.AngicGlobal.com)

<https://www.AngicGlobal.com> [Sales@AngicGlobal.com](mailto:Sales@AngicGlobal.com)

<b>SMTPLSM</b>	Bulletin K
	Surface mount spring-loaded captive panel screws. <span style="float: right;">SM</span>
<b>SMTPR</b>	Bulletin K
	Surface mount panel fastener retainer that is used with Type PSHP screw. <span style="float: right;">SM</span>
<b>SMTRA</b>	Bulletin K
	Surface mount R'ANGLE® fasteners provide strong re-usable threads at right angle to PC board. <span style="float: right;">SM</span>
<b>SMTSK</b>	Bulletin K
	Surface mount KEYHOLE® standoffs that eliminate the need for attaching screws. <span style="float: right;">SM</span>
<b>SMTSO, SMTSOB</b>	Bulletin K
	Surface mount spacers and nuts are available threaded and unthreaded. <span style="float: right;">SM</span>
<b>SMTSS</b>	Bulletin K
	Surface mount standoffs that eliminate the need for attaching screws. <span style="float: right;">SM</span>
<b>S0, S04, S0A, S0S</b>	Bulletin S0
	Thru-hole threaded and unthreaded standoffs installed with their heads flush with one surface of the mounting sheets. <span style="float: right;">SC</span>
<b>SOAG, SOSG</b>	Bulletin S0
	Grounding standoffs for clinching into metal chassis with "gripping teeth" at opposite end to firmly contact mating board. <span style="float: right;">SC</span>
<b>SP</b>	Bulletins CL & SS
	Specially hardened self-clinching nuts for installation into stainless steel sheets. <span style="float: right;">SC</span>
<b>SSA, SSC, SSS</b>	Bulletin SSA
	SNAP-TOP® standoffs featuring a spring action to hold a P.C. board securely without screws or threaded hardware. <span style="float: right;">SC</span>
<b>T, T4</b>	Bulletin MPF
	microPEM® TackPin® fasteners for compact electronic assemblies enable sheet-to-sheet attachment. <span style="float: right;">SC</span>
<b>TD, TDS</b>	Bulletin TD
	TY-D® self-clinching tie-mounts provide secure attachment points for mounting wires to electronic chassis or enclosure. <span style="float: right;">SC</span>

<b>TDO</b>	Bulletin TD
	TY-D® self-clinching hooks enable users to easily attach, remove, and return tie-bundled wires to their mounting points. <span style="float: right;">SC</span>
<b>TFH, TFHS</b>	Bulletin FH
	Non-flush studs for sheets as thin as .020" / 0.51 mm. <span style="float: right;">SC</span>
<b>THFE</b>	Bulletin FH
	Heavy-duty studs for sheets as thin as .031" / 0.8 mm. <span style="float: right;">SC</span>
<b>TK4, TKA</b>	Bulletin MPF
	microPEM® TackSert® pins designed to hold a top panel to a bottom panel by broaching into the bottom panel. <span style="float: right;">B</span>
<b>TPS, TP4</b>	Bulletin FH
	Flush-mounted pilot pins with chamfered end to make mating hole location easy. <span style="float: right;">SC</span>
<b>TPXS</b>	Bulletin FH
	Alignment pin for ATCA® faceplate fastening solutions. <span style="float: right;">SC</span>
<b>TS</b>	Bulletin MPF
	TackScrew® fasteners enable cost-effective sheet-to-sheet attachment by simply pressing into place. Can be removed by simply unscrewing. <span style="float: right;">SC</span>
<b>TS04</b>	Bulletin S0
	Standoffs for installation into ultra-thin stainless steel sheets as thin as .025" / 0.63 mm. <span style="float: right;">SC</span>
<b>TS0, TS0A, TS0S</b>	Bulletin S0
	Standoffs provide permanent threads in ultra-thin sheets. <span style="float: right;">SC</span>
<b>U, UL</b>	Bulletin FE
	Miniature nuts with strong threads. Available with locking or non-locking threads. <span style="float: right;">SC</span>
<b>WN, WNS</b>	Bulletin WN
	Self-locating projection weld nuts. The engineered projections prevent burn-outs in thin sheets. <span style="float: right;">W</span>

# SELF-CLINCHING FASTENER INSTALLATION DOS AND DON'TS

## "Dos"

- Do** provide mounting hole of specified size for each fastener.
- Do** install fastener into punch side of sheet.
- Do** make certain that shank (or pilot) is within hole before applying installation force.
- Do** apply squeezing force between parallel surfaces.
- Do** apply sufficient force to totally embed clinching ring around entire circumference and to bring shoulder squarely in contact with sheet. For some fasteners, installation will be complete when the head is flush with the panel surface.

## "Don'ts"

- Don't** attempt to install a 300 series stainless steel fastener into a stainless steel sheet.
- Don't** install steel or stainless steel fasteners in aluminum panels before anodizing or finishing.
- Don't** deburr mounting holes on either side of sheet before installing fasteners – deburring will remove metal required for clinching fastener into sheet.
- Don't** install fastener closer to edge of sheet than minimum edge distance indicated by manufacturer – unless a special fixture is used to restrict bulging of sheet edge.
- Don't** over-squeeze. It will crush the head, distort threads, and buckle the sheet. Approximate installation forces are listed in performance data tables. Use this info as a guide. Be certain to determine optimum installation force by test prior to production runs.
- Don't** attempt to insert fastener with a hammer blow – under any circumstances. A hammer blow won't permit the sheet metal to flow and develop an interlock with the fastener's contour.
- Don't** install screw in the head side of fastener. Install from opposite side so that the fastener load is toward sheet. The clinching force is designed only to hold the fastener during handling and to resist torque during assembly.
- Don't** install fastener on pre-painted side of panel.



Get quote »

Angic Global Solutions

1-888-872-0690

[AngicGlobal.com](https://www.AngicGlobal.com) 9

<https://www.AngicGlobal.com> [Sales@AngicGlobal.com](mailto:Sales@AngicGlobal.com)

PennEngineering offers a wide range of technical support assistance. Let us put our expertise to work for you. We can provide:

### Training

- ▶ On customer site group or individual training by a technical representative and/or PEM® factory personnel
- ▶ Tutorial materials on website

### Global Network of Engineering Representatives to:

- ▶ Provide local company liaison
- ▶ Provide application review/product selection
- ▶ Provide technical materials
- ▶ Provide on-site product training and new product updates
- ▶ Assist with quotations
- ▶ The representative nearest you can be found on our website. [rep/distributor locator](#)

### Application Engineering Services and Online Tools

- ▶ Application analysis/review
- ▶ Custom solutions
- ▶ Online technical papers
- ▶ Get answers to technical questions at [techsupport@pemnet.com](mailto:techsupport@pemnet.com)
- ▶ Customer assist performance testing
- ▶ Cost Savings Investigation (CSI)
- ▶ Custom design and product development
- ▶ Customer drawings
- ▶ Finite Element Analysis (FEA)
- ▶ Free samples on standard (catalog) products
- ▶ 3D Models (download or direct insert free on website)
- ▶ Free design PEMspec™ APP
- ▶ Instructional videos and animations

### Stay connected to PennEngineering

Now you can follow us for the latest news releases, new products, bulletin updates, tech tips, videos and more.



**Technical Lab Services** - Complete testing in accordance with NASM 25027, 45938 and ASTM as well as PEM® fastener test specs and customer parameters.

- ▶ Mechanical testing
- ▶ Compression
- ▶ Micro hardness (Knoop, Rockwell and superficial)
- ▶ Image analysis
- ▶ Tensile strength
- ▶ In sheet performance
- ▶ Thermal Cycling
- ▶ Corrosion and plating issues and analysis

**Prototype Development Center** - Shop equipped with latest CNC equipment to provide prototype or short run samples and necessary installation tooling.

Capabilities include:

- ▶ Turning
- ▶ Milling
- ▶ Drilling
- ▶ 3D Printing
- ▶ Installation
- ▶ Reaming
- ▶ Punching
- ▶ Grinding
- ▶ Assembly

### Installation Equipment

We can assess your application and recommend equipment that helps you achieve your lowest installed cost. PEMSERTER® and Haeger® systems can be developed to handle multiple fastener types simultaneously or even in-die equipment to address challenging component handling and fastener installation. For more information call us at 800-523-5321 (USA only) or 215-766-8853 or visit us at [www.pemnet.com](http://www.pemnet.com).



Haeger® 824 OneTouch 4e

PEMSERTER® In-Die System





PEM® floating self-clinching fasteners are available with or without locking threads.



# ALA™

## FLOATING SELF-CLINCHING FASTENERS

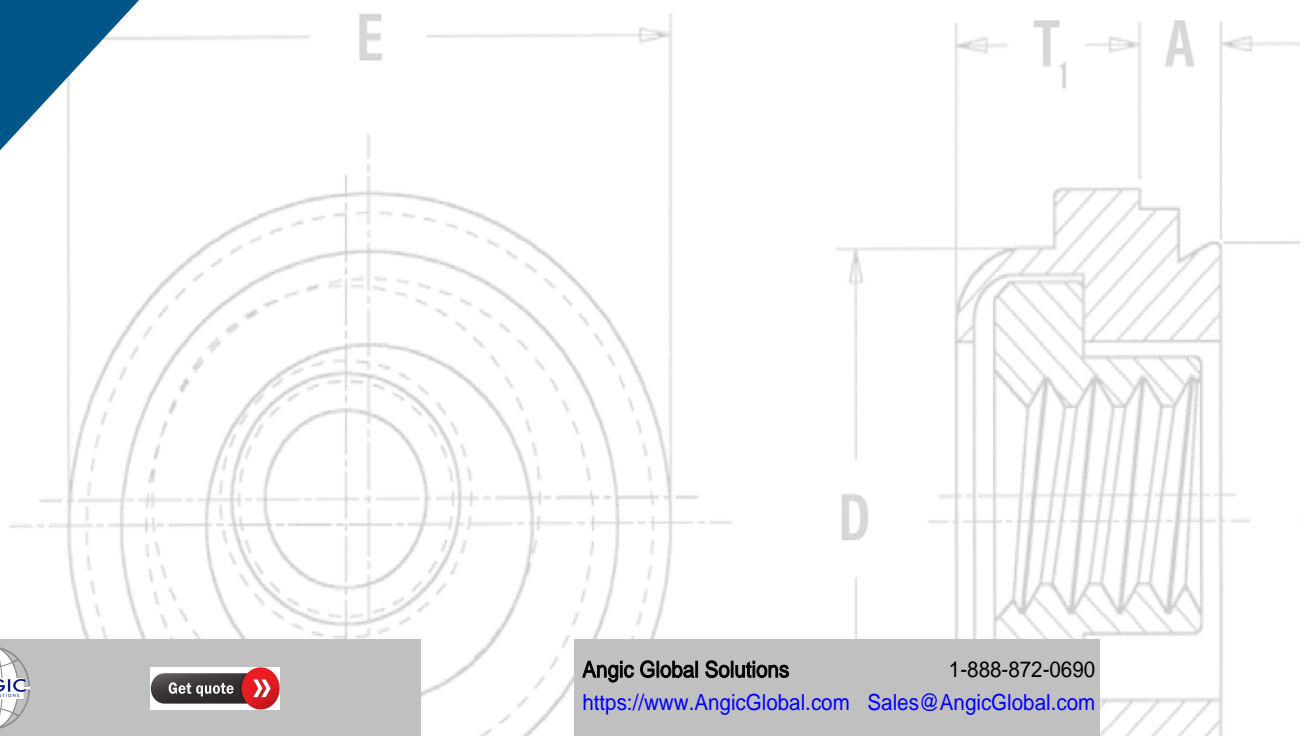

Get quote >>

Angic Global Solutions

1-888-872-0690

<https://www.AngicGlobal.com> [Sales@AngicGlobal.com](mailto:Sales@AngicGlobal.com)

# FLOATING SELF-CLINCHING FASTENERS

## Locking and Non-locking Threads

- Provide load-bearing threads in thin sheets
- Permit a total of .030"/0.76 mm adjustment for mating hole misalignment.
- Sheet remains flush on one side, and the fastener is permanently locked in place.
- Threads of the floating nut extend into the retainer shank for extra strength and support in assembly.

### AC™/AS™/LAC™/LAS™ floating Nuts

- Designed for clinching into steel or aluminum panels and sheets.
- Available with (LAC/LAS) or without (AC/AS) locking threads.

### A4™/LA4™ floating nuts

- Provide prevailing torque locking threads with performance equivalent to applicable NASM25027 specifications<sup>(1)</sup>.
- Designed for clinching into stainless steel panels and sheets.
- Available with (LA4) or without (A4) locking threads.



(1) To meet national aerospace standards and to obtain testing documentation, product must be ordered to US NASM45938/11 specifications. Check our web site for a complete Military Specification and National Aerospace Standards Reference Guide (Bulletin NASM). Screws for use with PEM self-clinching locking fasteners should be Class 3A/4h fit or no smaller than Class 2A/6g.

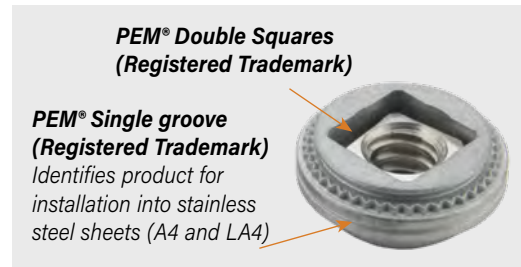
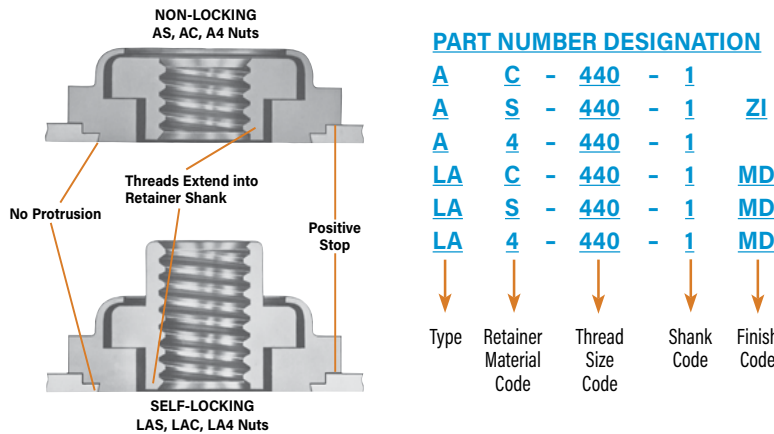

## AXIAL STRENGTH AND TIGHTENING TORQUE - TYPES LAC/LAS/LA4

UNIFIED	Thread Code	Locknut Min. Axial Strength (1) (lbs.)	Mating Screw Strength Level (1) (ksi)	Mating Screw Tightening Torque (2) (in. lbs.)
	440	1085	180	15.8
	632	1636	180	29.4
	832	2522	180	53.8
	032	3600	180	88.9
	0420	5728	180	186

METRIC	Thread Code	Locknut Min. Axial Strength (1) (kN)	Mating Screw Strength Level (1) (MPa)	Mating Screw Tightening Torque (2) (N-m)
	M3	6.14	1220	2.39
	M4	10.71	1220	5.57
	M5	17.3	1220	11.2
	M6	24.55	1220	19.1

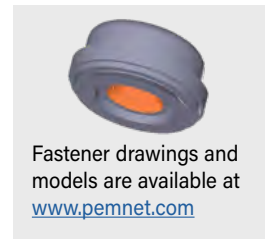

- (1) All LAC, LAS and LA4 locknuts have axial strength exceeding the minimum tensile strength of 180 ksi/Property Class 12.9 screws. Contact techsupport regarding assemble strength for higher strength screws.
- (2) Tightening torque shown will induce preload of 65% of locknut minimum axial strength with K or nut factor is equal to 0.20. In some applications tightening torque may need to be adjusted based on the actual K value. All tightening torques shown are based on 180 ksi/ Property Class 12.9 screws. For lower strength screws the tightening torque is proportionately less. For example, for 120 ksi screws, torque is 67% value shown. For 900 MPa screws (Property Class 9.8) torque value is 74% of value shown.

### A NOTE ABOUT HARDENED 400 SERIES STAINLESS STEEL

In order for self-clinching fasteners to work properly, the fastener must be harder than the sheet into which it is being installed. In the case of stainless steel panels, fasteners made from 300 Series Stainless Steel do not meet this hardness criteria. It is for this reason that A4 and LA4 400 series fasteners are offered. However, while these 400 Series fasteners install and perform well in 300 Series stainless sheets they should not be used if the end product:

- Will be exposed to any appreciable corrosive presence.
- Requires non-magnetic fasteners.
- Will be exposed to any temperatures above 300°F (149°C)

If any of these are issues, please contact [techsupport@pemnet.com](mailto:techsupport@pemnet.com) for other options.

# FLOATING SELF-CLINCHING FASTENERS

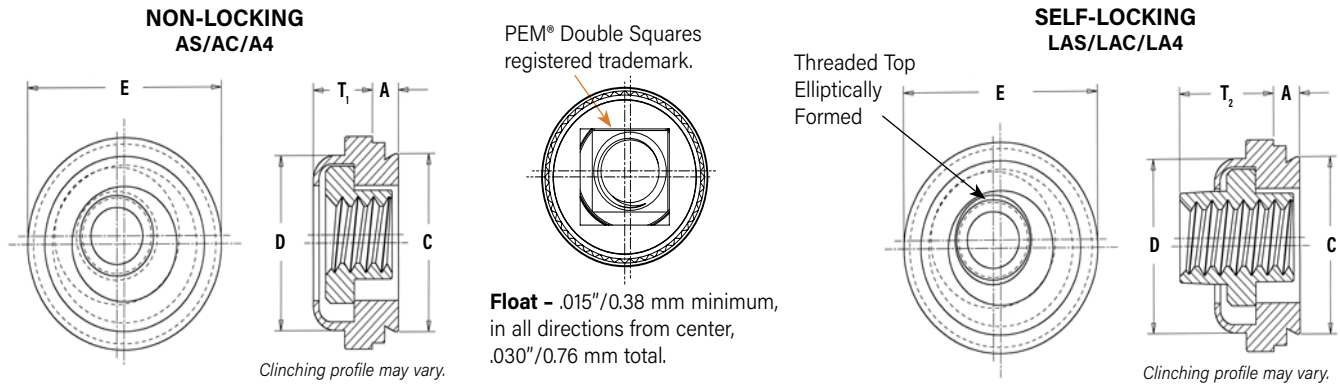

All dimensions are in inches.

UNIFIED	Thread Size	Type					Thread Code	Shank Code	A (Shank) Max.	Min. Sheet Thickness	Hole Size in Sheet +.003 -.000	C Max.	D Max.	E ±.015	T <sub>1</sub> Max.	T <sub>2</sub> Max.	Min. Dist. Hole $\phi$ To Edge	
		Non-Locking			Self-Locking													
		Fastener Material			Fastener Material													
		Steel	300 Series Stainless	400 Series Stainless	Steel	300 Series Stainless												400 Series Stainless
.112-40 (#4-40)	AS	AC	A4	LAS	LAC	LA4	440	1	.038	.038	.290	.289	.290	.360	.130	.190	.30	
									2 <sup>(1)</sup>	.054								.054
.138-32 (#6-32)	AS	AC	A4	LAS	LAC	LA4	632	1	.038	.038	.328	.327	.335	.390	.130	.200	.32	
									2 <sup>(1)</sup>	.054								.054
.164-32 (#8-32)	AS	AC	A4	LAS	LAC	LA4	832	1	.038	.038	.368	.367	.365	.440	.130	.210	.34	
									2 <sup>(1)</sup>	.054								.054
.190-24 (#10-24)	AS	AC	A4	LAS	LAC	LA4	024	1	.038	.038	.406	.405	.405	.470	.170	.270	.36	
									2 <sup>(1)</sup>	.054								.054
.190-32 (#10-32)	AS	AC	A4	LAS	LAC	LA4	032	1	.038	.038	.406	.405	.405	.470	.170	.270	.36	
									2 <sup>(1)</sup>	.054								.054
.250-20 (1/4-20)	AS	AC	-	LAS	LAC	-	0420	2	.054	.054	.515	.514	.510	.600	.210	.310	.42	
.250-28 (1/4-28)	AS	AC	-	LAS	LAC	-	0428	2	.054	.054	.515	.514	.510	.600	.210	.310	.42	

All dimensions are in millimeters.

METRIC	Thread Size x Pitch	Type					Thread Code	Shank Code	A (Shank) Max.	Min. Sheet Thickness	Hole Size in Sheet +0.08	C Max.	D Max.	E ±0.38	T <sub>1</sub> Max.	T <sub>2</sub> Max.	Min. Dist. Hole $\phi$ To Edge	
		Non-Locking			Self-Locking													
		Fastener Material			Fastener Material													
		Steel	300 Series Stainless	400 Series Stainless	Steel	300 Series Stainless												400 Series Stainless
M3 x 0.5	AS	AC	A4	LAS	LAC	LA4	M3	1	0.97	0.97	7.37	7.35	7.37	9.14	3.31	4.83	762	
									2 <sup>(1)</sup>	1.38								1.38
M4 x 0.7	AS	AC	A4	LAS	LAC	LA4	M4	1	0.97	0.97	9.35	9.33	9.28	11.18	3.31	5.34	8.64	
									2 <sup>(1)</sup>	1.38								1.38
M5 x 0.8	AS	AC	A4	LAS	LAC	LA4	M5	1	0.97	0.97	10.31	10.29	10.29	11.94	4.32	6.86	9.14	
									2 <sup>(1)</sup>	1.38								1.38
M6 x 1	AS	AC	-	LAS	LAC	-	M6	2	1.38	1.38	13.08	13.06	12.96	15.24	5.34	7.88	10.67	

(1) This shank code is not available for A4 and LA4 nuts.

## MATERIAL AND FINISH SPECIFICATIONS

Type	Threads		Fastener Materials					Standard Finishes					For Use In Sheet Hardness (2)	
	Non-locking	Self-locking	Retainer			Nut		Non-locking		Self-locking				
			Retainer & Nut	Retainer & Nut	Retainer	Retainer	Nut							
AS	Internal, ASME B1.1, 2B/ASME B1.13M, 6H	Internal, UNJ Class 3B per ASME B1.15 / MJ Class 4H6H per ASME B1.21M (M6 thread 4H5H)	Hardened Carbon Steel	Hardened 400 Series Stainless Steel	300 Series Stainless Steel	Carbon Steel	300 Series Stainless Steel	Zinc Plated per ASTM B633, SC1 (5µm), Type III, Colorless (3)	Passivated and/or tested per ASTM A380	Zinc Plated per ASTM B633, SC1 (5µm), Type III Colorless (3)	Passivated and/or tested per ASTM A380	Black Dry-film Lubricant (4)	HRB 70/ HB 125 or Less	HRB 88/ HB 183 or Less
AC	Internal, ASME B1.1, 2B/ASME B1.13M, 6H	Internal, UNJ Class 3B per ASME B1.15 / MJ Class 4H6H per ASME B1.21M (M6 thread 4H5H)	Hardened Carbon Steel	Hardened 400 Series Stainless Steel	300 Series Stainless Steel	Carbon Steel	300 Series Stainless Steel	Zinc Plated per ASTM B633, SC1 (5µm), Type III, Colorless (3)	Passivated and/or tested per ASTM A380	Zinc Plated per ASTM B633, SC1 (5µm), Type III Colorless (3)	Passivated and/or tested per ASTM A380	Black Dry-film Lubricant (4)	HRB 70/ HB 125 or Less	HRB 88/ HB 183 or Less
A4	Internal, ASME B1.1, 2B/ASME B1.13M, 6H	Internal, UNJ Class 3B per ASME B1.15 / MJ Class 4H6H per ASME B1.21M (M6 thread 4H5H)	Hardened Carbon Steel	Hardened 400 Series Stainless Steel	300 Series Stainless Steel	Carbon Steel	300 Series Stainless Steel	Zinc Plated per ASTM B633, SC1 (5µm), Type III, Colorless (3)	Passivated and/or tested per ASTM A380	Zinc Plated per ASTM B633, SC1 (5µm), Type III Colorless (3)	Passivated and/or tested per ASTM A380	Black Dry-film Lubricant (4)	HRB 70/ HB 125 or Less	HRB 88/ HB 183 or Less
LAS	Internal, ASME B1.1, 2B/ASME B1.13M, 6H	Internal, UNJ Class 3B per ASME B1.15 / MJ Class 4H6H per ASME B1.21M (M6 thread 4H5H)	Hardened Carbon Steel	Hardened 400 Series Stainless Steel	300 Series Stainless Steel	Carbon Steel	300 Series Stainless Steel	Zinc Plated per ASTM B633, SC1 (5µm), Type III, Colorless (3)	Passivated and/or tested per ASTM A380	Zinc Plated per ASTM B633, SC1 (5µm), Type III Colorless (3)	Passivated and/or tested per ASTM A380	Black Dry-film Lubricant (4)	HRB 70/ HB 125 or Less	HRB 88/ HB 183 or Less
LAC	Internal, ASME B1.1, 2B/ASME B1.13M, 6H	Internal, UNJ Class 3B per ASME B1.15 / MJ Class 4H6H per ASME B1.21M (M6 thread 4H5H)	Hardened Carbon Steel	Hardened 400 Series Stainless Steel	300 Series Stainless Steel	Carbon Steel	300 Series Stainless Steel	Zinc Plated per ASTM B633, SC1 (5µm), Type III, Colorless (3)	Passivated and/or tested per ASTM A380	Zinc Plated per ASTM B633, SC1 (5µm), Type III Colorless (3)	Passivated and/or tested per ASTM A380	Black Dry-film Lubricant (4)	HRB 70/ HB 125 or Less	HRB 88/ HB 183 or Less
LA4	Internal, ASME B1.1, 2B/ASME B1.13M, 6H	Internal, UNJ Class 3B per ASME B1.15 / MJ Class 4H6H per ASME B1.21M (M6 thread 4H5H)	Hardened Carbon Steel	Hardened 400 Series Stainless Steel	300 Series Stainless Steel	Carbon Steel	300 Series Stainless Steel	Zinc Plated per ASTM B633, SC1 (5µm), Type III, Colorless (3)	Passivated and/or tested per ASTM A380	Zinc Plated per ASTM B633, SC1 (5µm), Type III Colorless (3)	Passivated and/or tested per ASTM A380	Black Dry-film Lubricant (4)	HRB 70/ HB 125 or Less	HRB 88/ HB 183 or Less
Part number codes for finishes								ZI	None	MD				

(2) HRB - Hardness Rockwell "B" Scale. HB - Hardness Brinell.

(3) See PEM Technical Support section of our web site ([www.pemnet.com](http://www.pemnet.com)) for related plating standards and specifications.

(4) Temperature limit 400° F / 204° C.



Get quote >>

Angic Global Solutions

1-888-872-0690 [www.angic.com](http://www.angic.com) 13

<https://www.AngicGlobal.com> Sales@AngicGlobal.com

# FLOATING SELF-CLINCHING FASTENERS

## INSTALLATION

1. Prepare properly sized mounting hole in sheet. Do not perform any secondary operations such as deburring.
2. Place fastener into the anvil hole and place the mounting hole (preferably the punch side) over the shank of the fastener.
3. With installation punch and anvil surfaces parallel, apply sufficient squeezing force until anvil contacts the mounting sheet. Drawing shows suggested tooling for applying these forces.

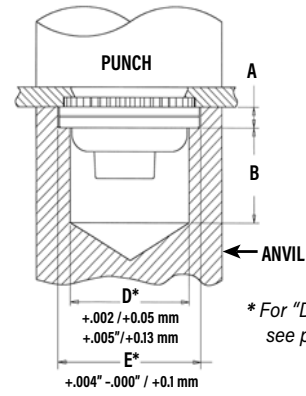

\* For "D" and "E", see page 13.

## PEMSERTER® Installation Tooling - AC/AS/LAC/LAS/A4/LA4 NUTS

Thread Code	Counterbore		Hole Depth Below Counterbore		Anvil Part Number	Punch Part
	A		B			
440/M3	±.001	±0.03	±.005	±0.13	8013889	975200048
632	.054	1.37	.258	6.55	8013890	975200048
832/M4	.054	1.37	.258	6.55	8013891	975200048
032/M5	.071	1.8	.241	6.12	8013892	975200048
0420/M6	.092	2.34	.220	5.59	8021392	8012030

### INSTALLATION NOTES

- For best results we recommend using a Haeger® or PEMSERTER® machine for installation of PEM® self-clinching fasteners. Please check our website for more information.
- Visit the Animation Library on our website to view the installation process for [select products](#).

## PERFORMANCE DATA<sup>(1)(2)</sup>

### AC/AS/LAC/LAS NUTS

UNIFIED	Thread Code	Shank Code	Test Sheet Material					
			5052-H34 Aluminum			Cold-Rolled Steel		
			Installation (lbs.)	Retainer Pushout (lbs.)	Retainer Torque-out (in. lbs.)	Installation (lbs.)	Retainer Pushout (lbs.)	Retainer Torque-out (in. lbs.)
440	1	1500	215	65	3000	300	85	
	2	2000	225	80			150	
632	1	2000	240	140	3000	300	150	
	2		250	150			175	
832	1	2000	250	140	3000	300	150	
	2		265	150			200	
032	1	2000	300	150	3500	400	150	
	2		350	175			200	
0420	2	3000	400	325	5000	500	325	
0428								

METRIC	Thread Code	Shank Code	Test Sheet Material					
			5052-H34 Aluminum			Cold-Rolled Steel		
			Installation (kN)	Retainer Pushout (N)	Retainer Torque-out (N-m)	Installation (kN)	Retainer Pushout (N)	Retainer Torque-out (N-m)
M3	1	6.7	956	7.3	13.3	1334	9.6	
	2	8.9	1000	9	13.3	1334	16.9	
M4	1	8.9	1112	15.8	13.3	1334	16.9	
	2	8.9	1178	16.9	13.3	1779	22.6	
M5	1	8.9	1334	16.9	15.6	1779	16.9	
	2	8.9	1556	19.7	15.6	2001	22.6	
M6	2	13.3	1779	36.7	22.2	2224	36.7	

### A4/LA4<sup>(3)</sup> NUTS

UNIFIED	Thread Code	Test Sheet Material		
		300 Series Stainless Steel		
		Installation (lbs.)	Retainer Pushout (lbs.)	Retainer Torque-out (in. lbs.)
440	9000	200	85	
632	10000	200	85	
832	12000	200	85	
032	13000	250	125	

METRIC	Thread Code	Test Sheet Material		
		300 Series Stainless Steel		
		Installation (kN)	Retainer Pushout (N)	Retainer Torque-out (N-m)
M3	40	890	9.6	
M4	53	890	9.6	
M5	57	1100	14.1	

(3) Specifically designed for installation into stainless steel.

(1) Published installation forces are for general reference. Actual set-up and confirmation of complete installation should be made by observing proper seating of fastener as described in the installation steps. Other performance values reported are averages when all proper installation parameters and procedures are followed. Variations in mounting hole size, sheet material, and installation procedure may affect performance. Performance testing this product in your application is recommended. We will be happy to provide technical assistance and/or samples for this purpose.

(2) For LAC, LAS and LA4 nuts, thread locking performance is equivalent to applicable NASM25027 specifications. Consult document PEM-REF25027 for details.



PEM® self-clinching blind fasteners are used in applications requiring closed thread ends.



**B™**

## SELF-CLINCHING BLIND FASTENERS

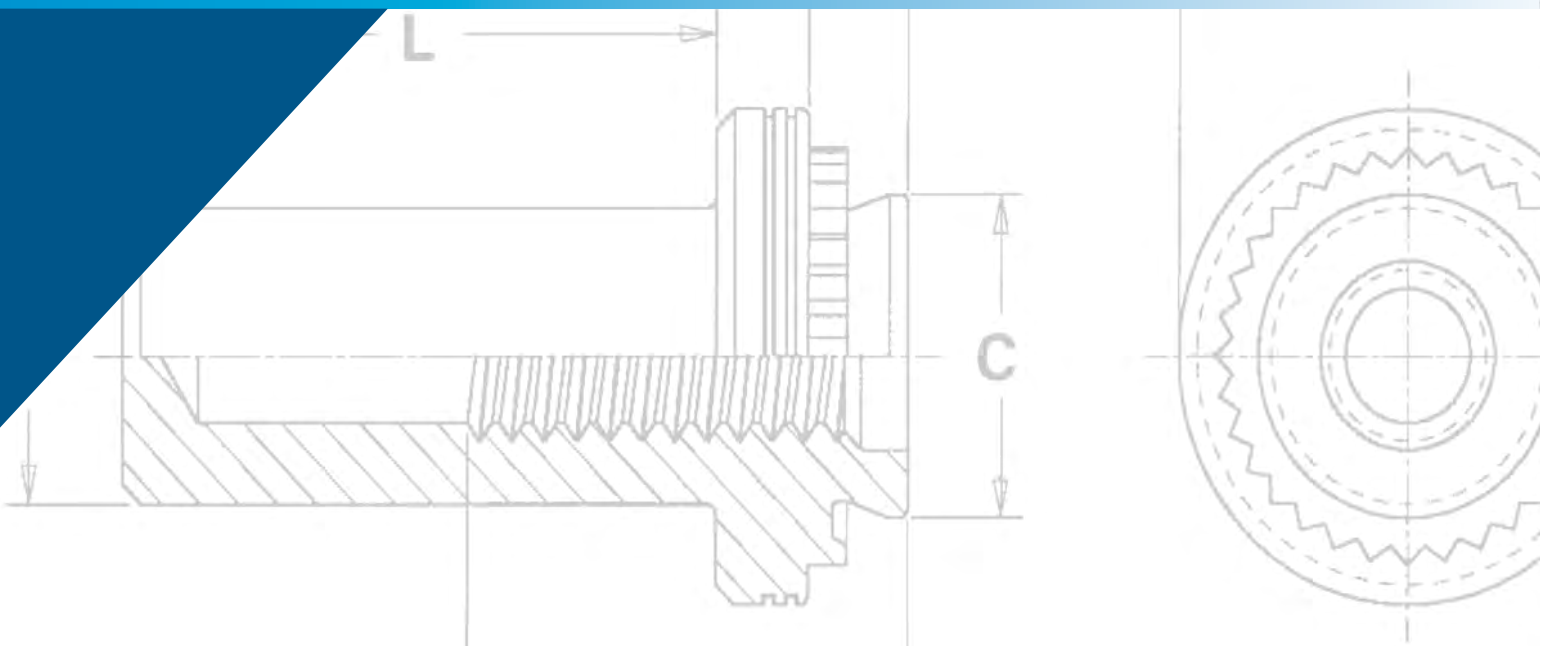

Get quote »

F

Angic Global Solutions

1-888-872-0690

<https://www.AngicGlobal.com> [Sales@AngicGlobal.com](mailto:Sales@AngicGlobal.com)

# SELF-CLINCHING BLIND FASTENERS

**PEM® brand self-clinching blind fasteners provide permanently mounted blind threads in metal sheets as thin as .040"/1 mm.**

- Provides barrier to protect threads against foreign matter.
- Limits screw penetration, protecting internal components from potential damage.
- Available on special order with free-running locking thread feature.

PEM® blind fasteners employ the proven PEM® self-clinching design and are easily installed into properly sized holes. Shanks of PEM® fasteners act as their own pilots. PEM® blind fasteners can be installed with any standard press applying squeezing forces between parallel surfaces.

PEM® self-clinching blind fasteners are available in thread sizes from #4-40 through 1/4-20 / M3 through M6 in carbon or stainless steel.

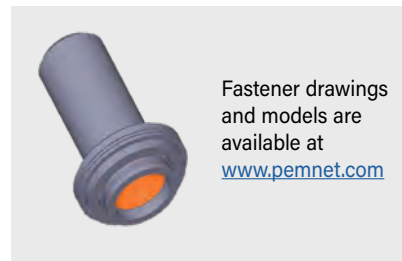
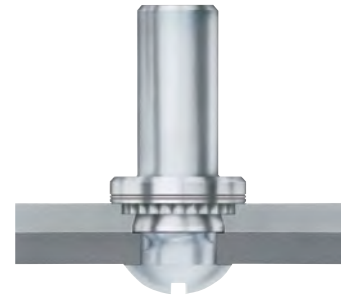

# SELF-CLINCHING BLIND FASTENERS

Metric parts are identified by large chamfer at blind end.

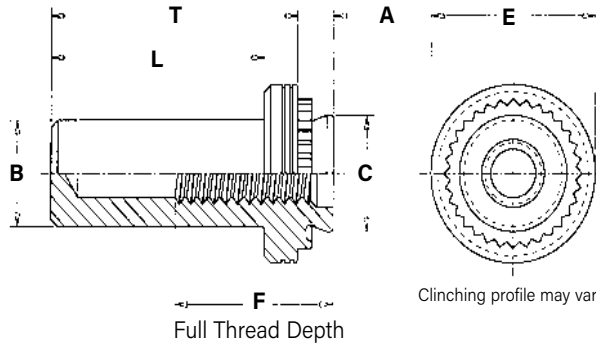
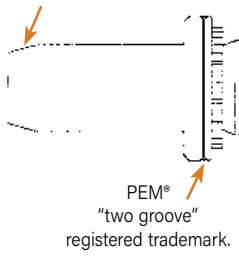

## PART NUMBER DESIGNATION

**B** - **832** - **2** **ZI**  
**B** **S** - **832** - **2**  
 ↓ ↓ ↓ ↓ ↓  
 Type Material Thread Size Code Shank Code Finish

All dimensions are in inches.

UNIFIED	Thread Size	Type		Thread Code (I)	Shank Code	A (Shank) Max.	Min. Sheet Thickness	Hole Size in Sheet + .003 - .000	B Max.	C Max.	E ± .010	F Min.	L Max.	T ± .010	Min. Dist. Hole $\varnothing$ to Edge
		Fastener Material													
		Steel	Stainless Steel												
.112-40 (#4-40)	B	BS	440	1	.038	.040	.166	.150	.165	.250	.210	.335	.380	.19	
				2	.054	.056									
.138-32 (#6-32)	B	BS	632	1	.038	.040	.1875	.169	.187	.280	.230	.335	.380	.22	
				2	.054	.056									
.164-32 (#8-32)	B	BS	832	1	.038	.040	.213	.204	.212	.310	.280	.385	.440	.27	
				2	.054	.056									
.190-32 (#10-32)	B	BS	032	1	.038	.040	.250	.235	.249	.340	.280	.385	.440	.28	
				2	.054	.056									
.250-20 (1/4-20)	B	BS	0420	1	.054	.056	.344	.305	.343	.430	.310	.500	.560	.34	
				2	.087	.090									

All dimensions are in millimeters.

METRIC	Thread Size x Pitch	Type		Thread Code (I)	Shank Code	A (Shank) Max.	Min. Sheet Thickness	Hole Size in Sheet + 0.08	B Max.	C Max.	E ± 0.25	F Min.	L Max.	T ± 0.25	Min. Dist. Hole $\varnothing$ to Edge
		Fastener Material													
		Steel	Stainless Steel												
M3 x 0.5	B	BS	M3	1	0.97	1	4.22	3.84	4.2	6.35	5.3	8.5	9.6	4.8	
				2	1.38	1.4									
M4 x 0.7	B	BS	M4	1	0.97	1	5.41	5.2	5.38	7.95	7.1	9.8	11.2	6.9	
				2	1.38	1.4									
M5 x 0.8	B	BS	M5	1	0.97	1	6.35	6.02	6.33	8.75	7.1	9.8	11.2	7.1	
				2	1.38	1.4									
M6 x 1	B	BS	M6	1	1.38	1.4	8.75	7.8	8.73	11.1	7.8	12.7	14.3	8.6	
				2	2.21	2.29									

(1) PEM® B™ nuts are available on special order with a free-running locking thread feature allowing mating screw to turn freely until clamp load is applied. For more information, contact PEM® [Technical Support](#).

## MATERIAL AND FINISH SPECIFICATIONS

Type	Threads	Fastener Materials		Standard Finishes		For Use in Sheet Hardness: (2)	
	Internal, ASME B1.1, 2B / ASME B1.13M, 6H	Hardened Carbon Steel	300 Series Stainless Steel	Passivated and/or Tested Per ASTM A380	Zinc Plated per ASTM B633, SC1 (5µm), Type III, Colorless (1)	HRB 80 / HB 150 or less	HRB 70 / HB 125 or less
B	▪	▪			▪	▪	
BS	▪		▪	▪			▪
Part Number Code For Finishes				None	ZI		

(1) See PEM [Technical Support](#) section of our web site for related plating standards and specifications.  
 (2) HRB - Hardness Rockwell "B" Scale. HB - Hardness Brinell.



Get quote >>

Angic Global Solutions

1-888-872-0690 [net.com](#) 17

<https://www.AngicGlobal.com> Sales@AngicGlobal.com

# SELF-CLINCHING BLIND FASTENERS

## INSTALLATION

1. Prepare properly sized mounting hole in the sheet. Do not perform any secondary operations such as deburring.
2. Place the barrel of the fastener into the anvil hole and place the mounting hole (preferably the punch side) over the shank of the fastener.
3. With the installation punch and anvil surfaces parallel, apply squeezing force until the flange contacts the mounting sheet. The sketch at the right indicates suggested tooling for applying these forces.

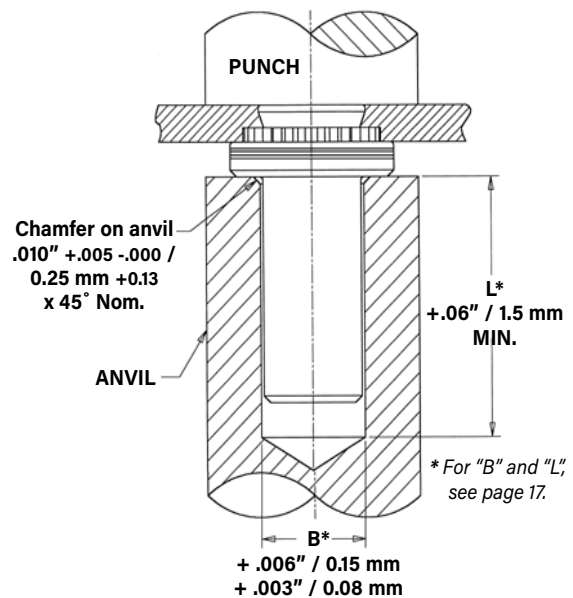

## PEMSERTER® Installation Tooling

Type	Thread Code	Anvil Part Number	Punch Part Number
B/BS	440/M3	975200001	975200048
B/BS	632	975200002	975200048
B/BS	832/M4	975200003	975200048
B/BS	032/M5	975200004	975200048
B/BS	0420/M6	975200005	975200048

### INSTALLATION NOTES

- For best results we recommend using a Haeger® or PEMSERTER® machine for installation of PEM® self-clinching fasteners. Please check our [website](#) for more information.
- Visit the Animation Library on our website to view the installation process [for this product](#).

## PERFORMANCE DATA<sup>(1)</sup>

UNIFIED	Thread Code	Shank Code	Sheet Thickness (in.)	Test Sheet Material					
				5052-H34 Aluminum			Cold-Rolled Steel		
				Installation (lbs.)	Pushout (lbs.)	Torque-out (in. lbs.)	Installation (lbs.)	Pushout (lbs.)	Torque-out (in. lbs.)
440	1	.040	1600	90	10	2500	125	13	
	2	.056	2000	170	13	3500	230	18	
632	1	.040	1800	95	17	3000	130	18	
	2	.056	2800	190	22	4000	260	28	
832	1	.040	2000	105	23	3500	135	30	
	2	.056	3000	220	35	5000	285	45	
032	1	.040	2100	110	32	4000	140	35	
	2	.056	3500	190	50	5000	250	60	
0420	1	.056	4000	315	90	6000	400	105	
	2	.090							

METRIC	Thread Code	Shank Code	Sheet Thickness (mm)	Test Sheet Material					
				5052-H34 Aluminum			Cold-Rolled Steel		
				Installation (kN)	Pushout (N)	Torque-out (N-m)	Installation (kN)	Pushout (N)	Torque-out (N-m)
M3	1	1	71	400	1.15	11.1	550	1.5	
	2	1.4	9	750	1.47	14	1010	2.05	
M4	1	1	8.9	470	2.6	15.6	600	3.4	
	2	1.4	12.5	970	4	20	1250	5.1	
M5	1	1	9.3	480	3.6	17.8	620	4	
	2	1.4	14	845	5.7	25	1112	6.8	
M6	1	1.4	178	1400	10.2	25.7	1760	11.9	
	2	2.3							

(1) Published installation forces are for general reference. Actual set-up and confirmation of complete installation should be made by observing proper seating of fastener as described in the installation steps. Other performance values reported are averages when all proper installation parameters and procedures are followed. Variations in mounting hole size, sheet material, and installation procedure may affect performance. Performance testing this product in your application is recommended. We will be happy to provide technical assistance and/or samples for this purpose.



PEM® concealed-head self-clinching studs and standoffs install permanently and promote smooth designs.



**CH™**

**CONCEALED-HEAD  
SELF-CLINCHING  
STUDS AND STANDOFFS**

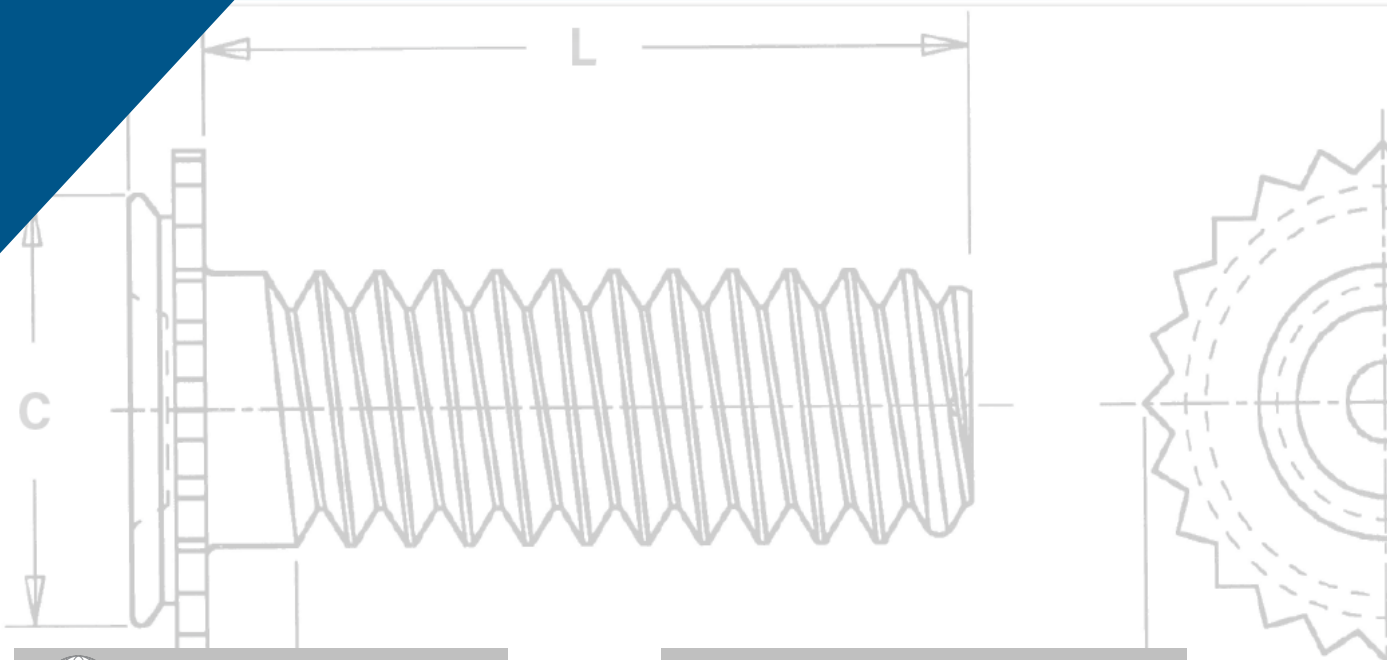

Get quote >>

Angic Global Solutions

1-888-872-0690

<https://www.AngicGlobal.com> [Sales@AngicGlobal.com](mailto:Sales@AngicGlobal.com)

# CONCEALED-HEAD SELF-CLINCHING STUDS AND STANDOFFS

## Concealed-head self-clinching studs and standoffs install permanently and promote smooth designs:

- Install permanently in steel or aluminum sheets as thin as .062" / 1.6 mm to provide strong and reusable threads for mating hardware in a wide range of assembly applications.
- Allow the side of the sheet opposite installation to remain smooth and unmarred.
- One side installation additionally serves to satisfy strict ingress protection (IP) requirements where the sheet must remain completely sealed from air, liquid, dust, gases or other potentially infiltrating elements.
- Only require a blind milled hole to the recommended size and minimum depth.
- Install using a PEMSERTER® press or other standard press.
- CFHC™ studs can be ordered to NAS63540/4 specifications.<sup>(1)</sup>

*(1) To meet national aerospace standards and to obtain testing documentation, Type CFHC studs must be ordered using appropriate NAS63540/4 part number. Check our web site for a complete Military Specification and National Aerospace Standards Reference Guide (Bulletin NASM).*



Concealed-head Stud

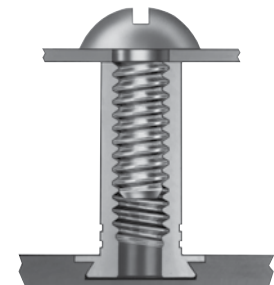

Concealed-head Standoff

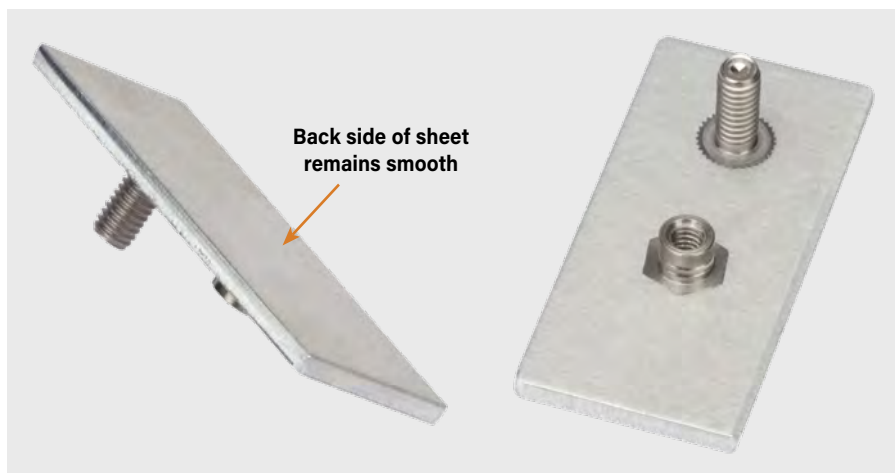

# CONCEALED-HEAD SELF-CLINCHING STUDS AND STANDOFFS

## CHA™, CFHA™, CHC™ AND CFHC™ ALUMINUM AND STAINLESS STEEL STUDS

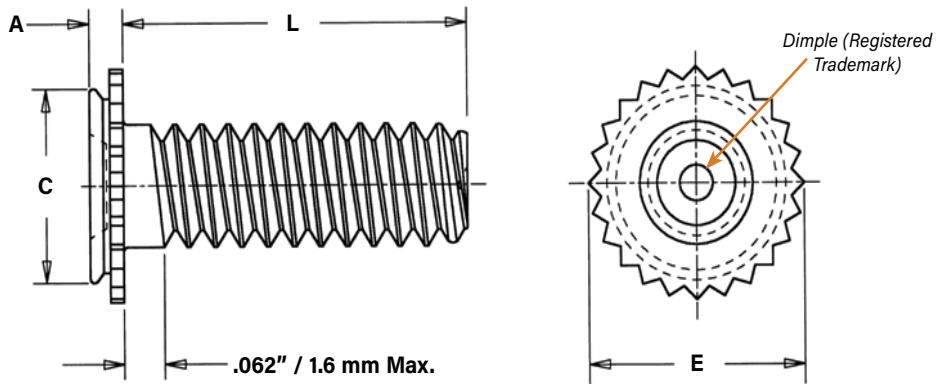

Clinching profile may vary.

All dimensions are in inches.

UNIFIED	Thread Size	Type		Thread Code	Length Code "L" ±.015 (Length code is in 16ths of an inch)					Min. Sheet Thickness	Blind Mounting Hole Dia. +.003 -0.000	Min. Depth of Blind Hole (1)	A (Shank) Max.	E ±.010	C Max.	Min. Dist. Hole $\varnothing$ To Edge	Max. Hole In Attached Parts
		Aluminum	Stainless Steel		.250	.375	.500	.625	.750								
	.112-40 (#4-40)	CHA	CHC	440	4	6	8	10	12	—	.062	.172	.043	.041	.205	.171	.156
	CFHA	CFHC	.093		.075	.071											
.138-32 (#6-32)	CHA	CHC	632	4	6	8	10	12	16	.062	.213	.043	.041	.250	.212	.188	.160
	CFHA	CFHC		.093	.075	.071											
.164-32 (#8-32)	CHA	CHC	832	4	6	8	10	12	16	.062	.290	.043	.041	.328	.289	.219	.185
	CFHA	CFHC		.093	.075	.071											
.190-32 (#10-32)	CHA	CHC	032	—	6	8	10	12	16	.062	.312	.043	.041	.350	.311	.250	.210
	CFHA	CFHC		.093	.075	.071											

All dimensions are in millimeters.

METRIC	Thread Size x Pitch	Type		Thread Code	Length Code "L" ±0.4 (Length code is in millimeters)					Min. Sheet Thickness	Blind Mounting Hole Dia. +0.08	Min. Depth of Blind Hole (1)	A (Shank) Max.	E ±0.25	C Max.	Min. Dist. Hole $\varnothing$ To Edge	Max. Hole In Attached Parts	
		Aluminum	Stainless Steel		6	8	10	12	16									20
	M3 x 0.5	CHA	CHC	M3	6	8	10	12	16	20	—	1.6	4.37	1.1	1.04	5.21	4.35	4
	CFHA	CFHC	2.4		1.91	1.8												
M4 x 0.7	CHA	CHC	M4	6	8	10	12	16	20	25	1.6	7.37	1.1	1.04	8.33	7.35	5.6	4.6
	CFHA	CFHC		2.4	1.91	1.8												
M5 x 0.8	CHA	CHC	M5	—	—	10	12	16	20	25	1.6	7.93	1.1	1.04	8.89	7.9	6.4	5.6
	CFHA	CFHC		2.4	1.91	1.8												

(1) Blind holes may be deeper than minimums except where sheet material is at or near minimum thickness. Fasteners should always be installed so the flange is flush with the surface of the sheet.

### PART NUMBER DESIGNATION

CH A - 632 - 6

CFH A - 632 - 6

CH C - 632 - 6

CFH C - 632 - 6

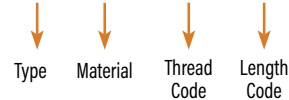

Get quote »

Angic Global Solutions

1-888-872-0690 [www.angic.com](http://www.angic.com) 21

<https://www.AngicGlobal.com> Sales@AngicGlobal.com

# CONCEALED-HEAD SELF-CLINCHING STUDS AND STANDOFFS

## CSS™ AND CSOS™ STAINLESS STEEL STANDOFFS

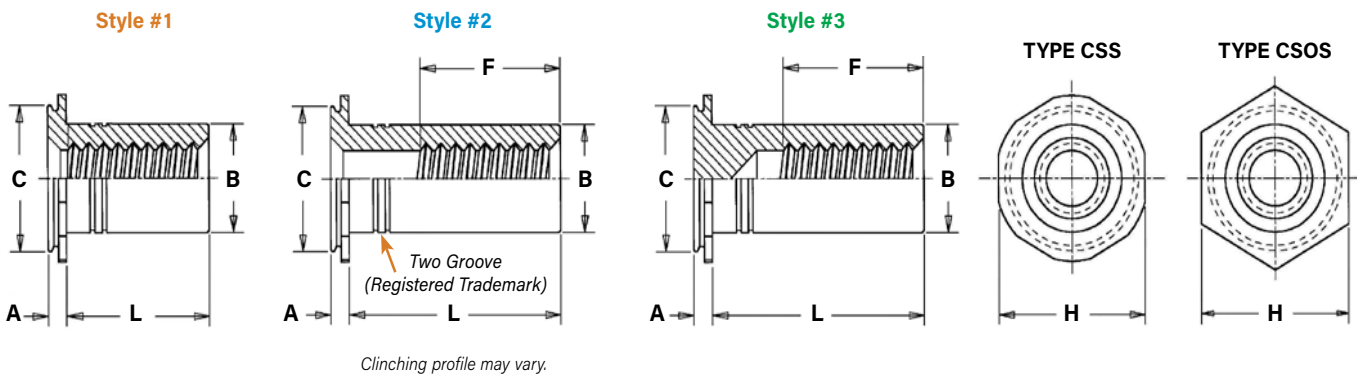

All dimensions are in inches.

UNIFIED	Thread Size	Type	Thread Code	Length Code "L" +.002 -.005 (Length code is in 16ths of an inch)							Min. Sheet Thickness	Blind Mounting Hole Dia. +.003 -.000	Min. Depth of Blind Hole (4)	Min. Depth Full Thread F	A (Shank) Max.	B Max. (5)	C Max.	H Nom.	Min. Dist. Hole To Edge	
				.187	.250	.312	.375	.500	.625	.750										1.00
	.112-.40 (#4-40)	CSS	440	3 <sup>(1)</sup>	4 <sup>(2)</sup>	5 <sup>(2)</sup>	6 <sup>(2)</sup>	8 <sup>(3)</sup>	10 <sup>(3)</sup>	12 <sup>(3)</sup>	16 <sup>(3)</sup>	.062	.213	.043	.188	.041	.165	.212	.250	.188
		CSOS																		
	.138-.32 (#6-32)	CSS	632	3 <sup>(1)</sup>	4 <sup>(1)</sup>	5 <sup>(2)</sup>	6 <sup>(2)</sup>	8 <sup>(3)</sup>	10 <sup>(3)</sup>	12 <sup>(3)</sup>	16 <sup>(3)</sup>	.062	.290	.043	.250	.041	.213	.289	.312	.219
		CSOS																		
	.164-.32 (#8-32)	CSS	832	3 <sup>(1)</sup>	4 <sup>(1)</sup>	5 <sup>(2)</sup>	6 <sup>(2)</sup>	8 <sup>(3)</sup>	10 <sup>(3)</sup>	12 <sup>(3)</sup>	16 <sup>(3)</sup>	.062	.312	.043	.250	.041	.245	.311	.344	.250
		CSOS																		
	.190-.32 (#10-32)	CSS	032	3 <sup>(1)</sup>	4 <sup>(1)</sup>	5 <sup>(1)</sup>	6 <sup>(1)</sup>	8 <sup>(2)</sup>	10 <sup>(3)</sup>	12 <sup>(3)</sup>	16 <sup>(3)</sup>	.062	.344	.043	.375	.041	.290	.343	.375	.281
		CSOS																		
	.250-.20 (1/4-20)	CSS	0420	3 <sup>(1)</sup>	4 <sup>(1)</sup>	5 <sup>(1)</sup>	6 <sup>(1)</sup>	8 <sup>(2)</sup>	10 <sup>(2)</sup>	12 <sup>(3)</sup>	16 <sup>(3)</sup>	.062	.390	.043	.375	.041	.354	.389	.438	.375
		CSOS																		

All dimensions are in millimeters.

METRIC	Thread Size x Pitch	Type	Thread Code	Length Code "L" +.005 -.013 (Length code is in millimeters)							Min. Sheet Thickness	Blind Mounting Hole Diameter +0.08	Min. Depth of Blind Hole (4)	Min. Depth Full Thread F	A (Shank) Max.	B Max. (5)	C Max.	H Nom.	Min. Dist. Hole To Edge	
				4 <sup>(1)</sup>	6 <sup>(1)</sup>	8 <sup>(2)</sup>	10 <sup>(3)</sup>	12 <sup>(3)</sup>	16 <sup>(3)</sup>	20 <sup>(3)</sup>										25 <sup>(3)</sup>
	M3 x 0.5	CSS	M3	4 <sup>(1)</sup>	6 <sup>(1)</sup>	8 <sup>(2)</sup>	10 <sup>(3)</sup>	12 <sup>(3)</sup>	16 <sup>(3)</sup>	20 <sup>(3)</sup>	25 <sup>(3)</sup>	1.6	5.41	1.1	5	1.04	4.2	5.39	6.35	4.8
		CSOS				8 <sup>(3)</sup>						1.91		1.83						
	M4 x 0.7	CSS	M4	4 <sup>(1)</sup>	6 <sup>(1)</sup>	8 <sup>(2)</sup>	10 <sup>(2)</sup>	12 <sup>(3)</sup>	16 <sup>(3)</sup>	20 <sup>(3)</sup>	25 <sup>(3)</sup>	1.6	7.92	1.1	6.5	1.04	6.23	7.9	8.74	6.4
		CSOS				10 <sup>(3)</sup>						1.91		1.83						
	M5 x 0.8	CSS	M5	4 <sup>(1)</sup>	6 <sup>(1)</sup>	8 <sup>(1)</sup>	10 <sup>(2)</sup>	12 <sup>(2)</sup>	16 <sup>(3)</sup>	20 <sup>(3)</sup>	25 <sup>(3)</sup>	1.6	8.74	1.1	9.6	1.04	7.37	8.72	9.53	7.2
		CSOS				8 <sup>(1)</sup>						1.91		1.83						
	M6 x 1	CSOS	M6	4 <sup>(1)</sup>	6 <sup>(1)</sup>	8 <sup>(1)</sup>	10 <sup>(2)</sup>	12 <sup>(2)</sup>	16 <sup>(3)</sup>	20 <sup>(3)</sup>	25 <sup>(3)</sup>	2.4	9.9	1.91	9.6	1.83	9	9.89	11.11	9.5

- Style #1.** Minimum thread length is equal to barrel length "L". Screw might not pass through shank end. Screws with lengths exceeding "L" should not be used or they may cause "jacking-out" of standoff from the sheet.
- Style #2.** Screw might not pass through unthreaded end. Screws with lengths exceeding "L" should not be used or they may cause "jacking-out" of standoff from the sheet.
- Style #3.** Blind.
- Blind mounting holes may be deeper than minimums except where sheet material is at or near minimum thickness. Fasteners should always be installed so the flange is flush with the surface of the sheet.
- If standoff is used as a bushing, the hole in attached part must not exceed "B" plus .020" / 0.51 mm.

### PART NUMBER DESIGNATION

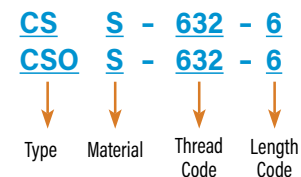

# CONCEALED-HEAD SELF-CLINCHING STUDS AND STANDOFFS

## MATERIAL AND FINISH SPECIFICATIONS

Type	Threads		Fastener Materials		Finish		For Use In Sheet Hardness (1)	
	External, ASME B1.1 2A / ASME B1.13M, 6g	Internal, ASME B1.1 2B / ASME B1.13M, 6H	Aluminum	300 Series Stainless Steel	No Finish	Passivated and/or tested per ASTM A380	HRB 70 / HB 125 or Less	HRB 50 / HB 89 or Less
CHA	•		•		•			•
CFHA	•		•		•			•
CHC	•			•		•		
CFHC	•			•		•		
CSS		•		•		•		•
CSOS		•		•		•		•

(1) HRB - Hardness Rockwell "B" Scale. HB - Hardness Brinell.

## INSTALLATION

1. Mill a round blind hole to the correct minimum depth.\*
2. Place fastener into anvil hole.
3. Place the mounting hole over the shank of the fastener.
4. With punch and anvil surfaces parallel, apply squeezing force until the flange is flush with the mounting sheet.

\* End mills available from PennEngineering. See chart below.

### INSTALLATION NOTES

- For best results we recommend using a Haeger® or PEMSERTER® machine for installation of PEM® self-clinching fasteners. Please check our website for more information.
- Visit the Animation Library on our website to view the installation process [for select products](#).

## END MILL INFORMATION

Double-ended, two-flute H.S.S. center-cutting end mills are available from stock.

PennEngineering does not manufacture center-cutting end mills, but we do keep a supply in stock for your convenience.



Thread Code	Fastener Type	Required Size End Mill	PEM Part No.
440, M3	CFHC, CHC, CFHA, CHA Studs	.172"	CHM-172
	CSOS, CSS Standoffs	.213"	CHM-213
632	CFHC, CHC, CFHA, CHA Studs	.213"	CHM-213
	CSOS, CSS Standoffs	.290"	CHM-290
832, M4	CFHC, CHC, CFHA, CHA Studs	.290"	CHM-290
	CSOS, CSS Standoffs	.312"	CHM-312
032, M5	CFHC, CHC, CFHA, CHA Studs	.312"	CHM-312
	CSOS, CSS Standoffs	.344"	CHM-344
0420, M6	CSOS Standoffs	.390"	CHM-390

CFHA, CFHC, CHC, CHA  
Concealed-head studs

CSOS, CSS  
Concealed-head standoffs

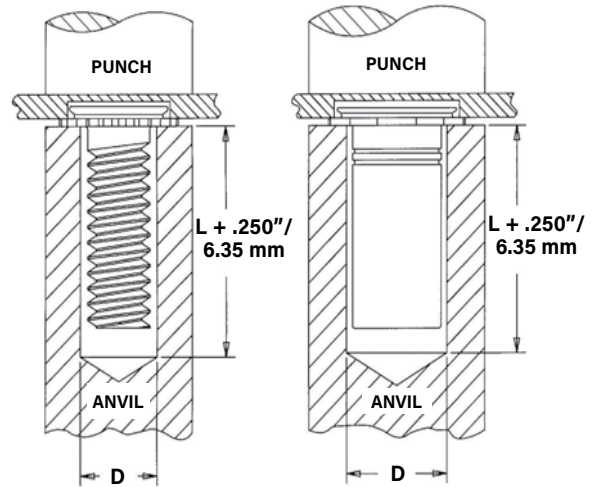

## PEMSERTER® Installation Tooling

All dimensions are in inches.

UNIFIED	Type	Thread Code	D +0.003 -0.000	Punch Part Number	Anvil Part Number
	CHA / CHC / CFHA / CFHC	440	.127	975200048	97020006300
	CHA / CHC / CFHA / CFHC	632	.139	975200048	970200007300
	CHA / CHC / CFHA / CFHC	832	.179	975200048	970200008300
	CHA / CHC / CFHA / CFHC	032	.205	975200048	970200009300
	CSS / CSOS	440	.170	975200048	970200014300
	CSS / CSOS	632	.218	975200048	970200015300
	CSS / CSOS	832	.250	975200048	970200016300
	CSS / CSOS	032	.295	975200048	970200017300
CSS / CSOS	0420	.358	975200048	970200018300	

All dimensions are in millimeters.

METRIC	Type	Thread Code	D +0.08	Punch Part Number	Anvil Part Number
	CHA / CHC / CFHA / CFHC	M3	3.4	975200048	970200229300
	CHA / CHC / CFHA / CFHC	M4	4.4	975200048	970200019300
	CHA / CHC / CFHA / CFHC	M5	5.4	975200048	970200020300
	CSS / CSOS	M3	4.33	975200048	970200014300
	CSS / CSOS	M4	6.36	975200048	970200016300
	CSS / CSOS	M5	7.5	975200048	970200017300
CSS / CSOS	M6	9.13	975200048	970200018300	



Get quote >>

Angic Global Solutions

1-888-872-0690 [www.angic.com](http://www.angic.com) 23

<https://www.AngicGlobal.com> Sales@AngicGlobal.com

# CONCEALED-HEAD SELF-CLINCHING STUDS AND STANDOFFS

## PERFORMANCE DATA<sup>(1)</sup>

Type	Thread Code	Max. Tightening Torque Ref. (in. lbs.)	Test Sheet Material			
			Cold-rolled Steel		5052-H34 Aluminum	
			Installation (lbs.)	Pullout (lbs.)	Installation (lbs.)	Pullout (lbs.)
<b>Concealed-head Standoffs</b>						
CSS	440	4.75	4,000	300	2,800	200
	632	8.75	4,500	350	3,000	240
	832	18	4,800	400	4,000	270
	032	32	5,500	450	5,000	290
CSOS	440	4.75	4,300	330	2,900	220
	632	8.75	5,000	360	3,200	240
	832	18	5,300	440	4,000	300
	032	32	6,000	600	5,000	400
	0420	64	6,500	650	5,500	430
<b>Concealed-head Studs</b>						
CHC	440	4.75	1,800	240	1,400	130
	632	8.75	2,500	260	1,800	160
	832	18	4,000	270	2,800	180
	032	32	5,000	290	4,000	210
CFHC	440	4.75	2,000	240	1,500	200
	632	8.75	2,700	350	2,500	260
	832	18	3,300	440	3,000	310
	032	32	4,000	680	3,500	360
CHA	440	2.85	(2)	(2)	1,400	125
	632	5.4	(2)	(2)	1,800	135
	832	10.8	(2)	(2)	2,800	145
	032	19.2	(2)	(2)	4,000	170
CFHA	440	2.85	(2)	(2)	1,500	190
	632	5.4	(2)	(2)	2,500	220
	832	10.8	(2)	(2)	3,000	240
	032	19.2	(2)	(2)	3,500	300

Type	Thread Code	Max. Tightening Torque Ref. (N-m)	Test Sheet Material			
			Cold-rolled steel		5052-H34 Aluminum	
			Installation (kN)	Pullout (N)	Installation (kN)	Pullout (N)
<b>Concealed-head Standoffs</b>						
CSS	M3	0.55	17.8	1330	12.5	890
	M4	2	21.3	1775	17.8	1200
	M5	3.6	24.5	2000	22.2	1290
CSOS	M3	.55	19.2	1465	12.9	975
	M4	2	23.6	1955	17.8	1335
	M5	3.6	26.7	2665	22.2	1775
	M6	7.2	28.9	2860	24.4	1915
<b>Concealed-head Studs</b>						
CHC	M3	0.55	8	1065	6.2	575
	M4	2	17.8	1200	12.5	800
	M5	3.6	22.2	1290	17.8	930
CFHC	M3	0.55	8.9	1065	6.7	890
	M4	2	14.7	1955	13.3	1375
	M5	3.6	17.8	3020	15.6	1600
CHA	M3	0.3	(2)	(2)	6.2	555
	M4	1.2	(2)	(2)	12.5	645
	M5	2.16	(2)	(2)	17.8	755
CFHA	M3	0.3	(2)	(2)	6.7	845
	M4	1.2	(2)	(2)	13.3	1065
	M5	2.16	(2)	(2)	15.6	1330

(1) Published installation forces are for general reference. Actual set-up and confirmation of complete installation should be made by observing proper seating of fastener as described in the installation steps. Other performance values reported are averages when all proper installation parameters and procedures are followed. Variations in mounting hole size, sheet material, and installation procedure may affect performance. Performance testing this product in your application is recommended. We will be happy to provide technical assistance and/or samples for this purpose.

(2) Not recommended.

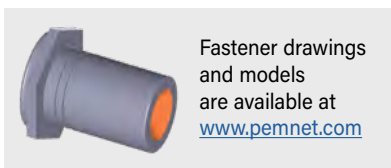

Fastener drawings and models are available at [www.pemnet.com](http://www.pemnet.com)

Look for the PEM® dimple trademark on studs and the PEM® "two groove" trademark on standoffs.

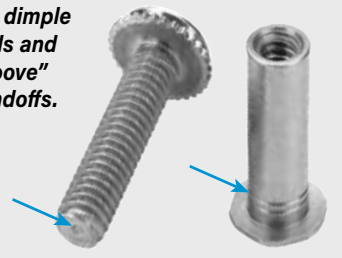



PEM® brand self-clinching nuts install permanently in aluminum, steel or stainless steel sheets.



**CL**<sup>TM</sup>

**SELF-CLINCHING  
NUTS**

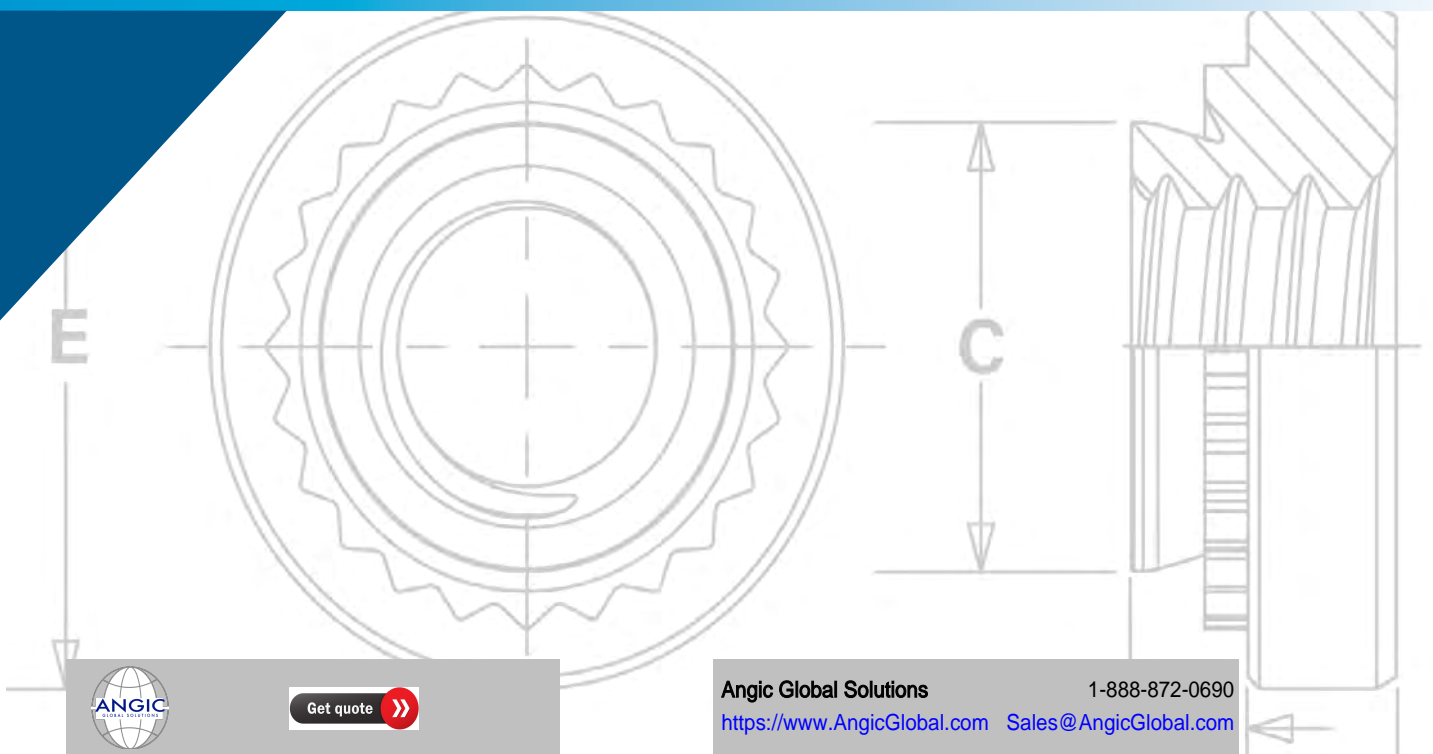

Get quote »

Angic Global Solutions





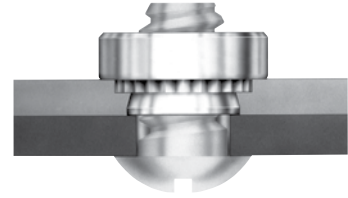

1-888-872-0690

<https://www.AngicGlobal.com> [Sales@AngicGlobal.com](mailto:Sales@AngicGlobal.com)

# SELF-CLINCHING NUTS

Self-clinching nuts are installed by placing them in properly sized holes in sheets and applying a parallel squeezing force to the head of the nut. The sheet metal surrounding the head cold flows into an undercut thereby making the fastener an integral part of the sheet. A serrated clinching ring prevents the fastener from rotating after installation.



<p><b>S™/SS™/CLA™/CLS™/CLSS™ nuts</b> provide load-bearing threads in thin sheets with high pushout and torque-out resistance - <b>PAGES 28 and 29</b></p>		<p><b>H™ (non-locking) and HNL™ (locking) nuts</b> have threads that provide high pushout and torque-out resistance - <b>PAGE 32</b></p>	
<p><b>SP™, PEM 300® nuts</b> provide strong load-bearing threads in stainless steel sheets as thin as .030"/0.8 mm - <b>PAGES 28 and 29</b></p>		<p><b>SH™ hard panel nuts</b> install into thin, harder, high strength steel materials - <b>PAGE 32</b></p>	
<p><b>PEM RT® free-running locknuts</b> are free-running until clamp load is induced. A modified thread angle on the loaded flank provides the vibration resistant locking feature- <b>PAGE 30</b></p>	<p style="text-align: center;"><b>NEW</b></p> 	<p><b>SMPS™/SMPP™ nuts</b> are for thinner sheet/close-to-edge applications - <b>PAGE 33</b></p>	
<p><b>Material and finish specifications - PAGE 33</b></p>			
<p><b>Installation - PAGES 34 and 35</b></p>			
<p><b>Performance data - PAGES 36 - 39</b></p>			

Many PEM self-clinching nuts in this bulletin are dimensionally equivalent to nuts manufactured to NASM45938/1 specifications. Consult our Marketing department for a complete Military Specifications and National Aerospace Standards guide (Bulletin NASM) on our website.

Screws for use with PEM self-clinching locking fasteners should be Class 3A/4h fit or no smaller than Class 2A/6g.

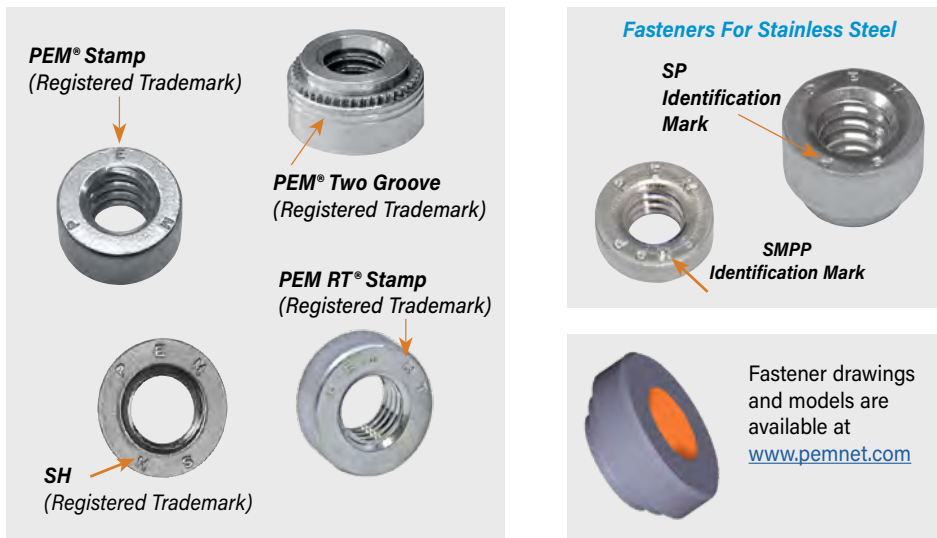

# SELF-CLINCHING NUTS

## PEM® SELF-CLINCHING NUT SELECTOR GUIDE

PEM Nut Type	Application Requires:									
	Recommended panel material (1)	Thinnest sheet .025" / 0.64 mm	Locking Threads		Closest centerline-to-edge distance	Superior corrosion resistance	Recommended for installation into stainless steel sheets	Compatible with aluminum anodizing	Harder high strength steel material	Non-magnetic
			Free-running	Prevailing torque						
S/SS/H	steel / aluminum									
CLS/CLSS	steel / aluminum					▪				▪
CLA	aluminum					▪		▪		▪
SP	stainless steel					▪	▪			▪
PEM RT®	steel / aluminum		▪							
SL	steel / aluminum			▪						
HNL	aluminum			▪						
SH	hardened alloy steel								▪	
SMPS	steel / aluminum	▪			▪	▪				▪
SMPP	stainless steel	▪			▪	▪	▪			▪

(1) Describes "best practice" for typical applications. Fasteners can be used in other panel materials not listed here if specified hardness limits are met. In all cases "For Use in Sheet Hardness" information is shown in chart on page 31.

### THREAD MASKING

PEM® PreTect™ thread masking solution provides protection for PEM® internally threaded fasteners. They reduce labor and protect threads from paint and powder coating processes. Fasteners are shipped with plugs and film (where applicable) already in place. [Click here](#) for more information.

Thread mask is available for applications where hardware is installed prior to painting. During assembly, the threads of the mating hardware will remove paint, electro deposited automotive under coatings, and weld spatter upon application of torque. PEM® nuts can be specially ordered with thread mask applied. [Click here](#) for more information.



Thread mask color may vary.

**"BC" suffix will be added to part number to designate thread mask to fastener.**

### AVAILABLE PEM® VARIMOUNT® FASTENING SYSTEM

The PEM® VariMount® fastening system (see PEM® Bulletin VM) utilizes a self-clinching nut paired with a round steel or stainless steel base plate to offer a clean and ready-made assembly for mounting into any rigid material or panel, including composites, plastics, and metals. Multiple radial holes in the base plate and a generous footprint provide effective mounting of the assembly. Mounting can be performed either on the front or through the back of a panel.



Get quote »

Angic Global Solutions

1-888-872-0690 [et.com](https://www.AngicGlobal.com) 27

<https://www.AngicGlobal.com> Sales@AngicGlobal.com

# SELF-CLINCHING NUTS

- S/SS nuts are recommended for use in steel or aluminum sheets HRB 80 / HB 150 or less.
- CLS/CLSS nuts are recommended for use in steel or aluminum sheets HRB 70 / HB 125 or less.
- SP nuts are recommended for use in stainless steel sheets HRB 90 / HB 192 or less.
- CLA nuts are recommended for use in steel or aluminum sheets HRB 50 / HB 82 or less.

## PART NUMBER DESIGNATION

<b>S</b>	-	<b>632</b>	-	<b>1</b>	<b>ZI</b>
<b>SS</b>	-	<b>032</b>	-	<b>1</b>	<b>ZI</b>
<b>CL</b>	<b>S</b>	-	<b>632</b>	-	<b>1</b>
<b>CLS</b>	<b>S</b>	-	<b>032</b>	-	<b>1</b>
<b>S</b>	<b>P</b>	-	<b>632</b>	-	<b>1</b>
<b>CL</b>	<b>A</b>	-	<b>632</b>	-	<b>1</b>

↓ Type   
 ↓ Material Code   
 ↓ Thread Size Code   
 ↓ Shank Code   
 ↓ Finish

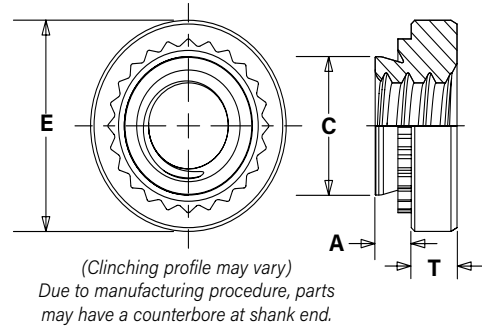

## S™/SS™/CLS™/CLSS™/SP™ NUTS

All dimensions are in inches.

Thread Size	Type			Thread Code	Shank Code	A (Shank) Max.	Rec. Min. Sheet Thickness (t)	Hole Size In Sheet +.003 -.000	C Max.	E ±.010	T ±.010	Min. Dist. Hole To Edge
	Carbon Steel	Stainless Steel	Hardened Stainless Steel									
.086-56 (#2-56)	S	CLS	SP	256	0	.030	.030	.166	.165	.250	.070	.19
					1	.038	.040					
					2	.054	.056					
.099-48 (#3-48)	S	CLS	-	348	0	.030	.030	.166	.165	.250	.070	.19
					1	.038	.040					
					2	.054	.056					
.112-40 (#4-40)	S	CLS	SP	440	0	.030	.030	.166	.165	.250	.070	.19
					1	.038	.040					
					2	.054	.056					
					3 <sup>(2)</sup>	.087	.090					
.138-32 (#6-32)	S	CLS	SP	632	0	.030	.030	.1875	.187	.280	.070	.22
					1	.038	.040					
					2	.054	.056					
					3 <sup>(2)</sup>	.087	.090					
.164-32 (#8-32)	S	CLS	SP	832	0	.030	.030	.213	.212	.310	.090	.27
					1	.038	.040					
					2	.054	.056					
					3 <sup>(2)</sup>	.087	.090					
.190-24 (#10-24)	SS	CLSS	SP	024	0	.030	.030	.250	.249	.340	.090	.28
					1	.038	.040					
					2	.054	.056					
					3 <sup>(2)</sup>	.087	.090					
.190-32 (#10-32)	SS	CLSS	SP	032	0	.030	.030	.250	.249	.340	.090	.28
					1	.038	.040					
					2	.054	.056					
					3 <sup>(2)</sup>	.087	.090					
.216-24 (#12-24)	S	CLS	-	1224	1	.038	.040	.277	.276	.370	.130	.31
					2	.054	.056					
					3	.087	.090					
.250-20 (1/4-20)	S <sup>(3)</sup>	CLS	SP	0420	0	.045	.047	.344	.343	.440	.170	.34
					1	.054	.056					
					2	.087	.090					
					3 <sup>(2)</sup>	.120	.125					
.250-28 (1/4-28)	S	CLS	-	0428	1	.054	.056	.344	.343	.440	.170	.34
					2	.087	.090					
					3	.120	.125					
.313-18 (5/16-18)	S <sup>(3)</sup>	CLS	SP	0518	1	.054	.056	.413	.412	.500	.230	.38
					2	.087	.090					
					3 <sup>(2)</sup>	.120	.125					
.313-24 (5/16-24)	S	CLS	SP	0524	1	.054	.056	.413	.412	.500	.230	.38
					2	.087	.090					
					3 <sup>(2)</sup>	.120	.125					
.375-16 (3/8-16)	S	CLS	SP	0616	1	.087	.090	.500	.499	.560	.270	.44
					2	.120	.125					
					3 <sup>(2)</sup>	.235	.250					
.375-24 (3/8-24)	S	CLS	SP	0624	1	.087	.090	.500	.499	.560	.270	.44
					2	.120	.125					
					3 <sup>(2)</sup>	.235	.250					
.438-20 (7/16-20)	S	-	-	0720	1	.087	.092	.562	.561	.687	.311	.562
.500-13 (1/2-13)	S	CLS	-	0813	1	.120	.125	.656	.655	.810	.360	.63
					2	.235	.250					
.500-20 (1/2-20)	S	CLS	-	0820	1	.120	.125	.656	.655	.810	.360	.63
					2	.235	.250					

- (1) For maximum performance, we recommend that you use the maximum shank length for your sheet thickness.
- (2) This shank code not available for SP nuts.
- (3) This thread size S nut, with a -2 shank code, can be installed successfully without the need to pre punch a mounting hole in a separate operation. See page 42 for more information.

The increased hardness of stainless steel panels requires careful consideration when installing self-clinching fasteners. See page 39 or refer to Fastener Installation [Dos and Don'ts](#) on our website.



# SELF-CLINCHING NUTS

## S™/SS™/CLS™/CLSS™/SP™ NUTS

(See drawing at top of page 28) All dimensions are in millimeters.

METRIC	Thread Size	Type			Thread Code	Shank Code	A (Shank) Max.	Rec. Min. Sheet Thickness (t)	Hole Size In Sheet +0.08	C Max.	E ±0.25	T ±0.25	Min. Dist. Hole To Edge
		Fastener Material											
		Carbon Steel	Stainless Steel	Hardened Stainless Steel									
M2 x 0.4	S	CLS	SP	M2	0 <sup>(2)</sup>	0.77	0.8	4.22	4.2	6.35	1.5	4.8	
					1	0.97	1						
					2	1.38	1.4						
M2.5 x 0.45	S	CLS	SP	M2.5	0	0.77	0.8	4.22	4.2	6.35	1.5	4.8	
					1	0.97	1						
					2	1.38	1.4						
M3 x 0.5	S	CLS	SP	M3	0	0.77	0.8	4.22	4.2	6.35	1.5	4.8	
					1	0.97	1						
					2	1.38	1.4						
M3.5 x 0.6	S	CLS	—	M3.5	0	0.77	0.8	4.75	4.73	7.11	1.5	5.6	
					1	0.97	1						
					2	1.38	1.4						
M4 x 0.7	S	CLS	SP	M4	0	0.77	0.8	5.41	5.38	7.87	2	6.9	
					1	0.97	1						
					2	1.38	1.4						
M5 x 0.8	SS	CLSS	SP	M5	0	0.77	0.8	6.35	6.33	8.64	2	7.1	
					1	0.97	1						
					2	1.38	1.4						
M6 x 1	S <sup>(3)</sup>	CLS	SP	M6	00 <sup>(2)</sup>	0.89	0.92	8.75	8.73	11.18	4.08	8.6	
					0 <sup>(2)</sup>	1.15	1.2						
					1	1.38	1.4						
					2	2.21	2.29						
M8 x 1.25	S <sup>(3)</sup>	CLS	SP	M8	1	1.38	1.4	10.5	10.47	12.7	5.47	9.7	
					2	2.21	2.29						
M10 x 1.5	S	CLS	SP	M10	1	2.21	2.29	14	13.97	17.35	7.48	13.5	
					2 <sup>(2)</sup>	3.05	3.18						
M12 x 1.75	S	—	—	M12	1	3.05	3.18	17	16.95	20.57	8.5	16	

## CLA™ NUTS (See drawing at top of page 28) All dimensions are in inches.

UNIFIED	Thread Size	Type		Thread Code	Shank Code	A (Shank) Max.	Min. Sheet Thickness (t)	Hole Size In Sheet ±.003 -.000	C Max.	E ±.010	T ±.010	Min. Dist. Hole To Edge
		Fastener Material										
		Aluminum										
.086-56 (#2-56)	CLA	256	1	.038	.040	.166	.165	.250	.070	.19		
			2	.054	.056							
.112-40 (#4-40)	CLA	440	1	.038	.040	.1875	.187	.250	.090	.22		
			2	.054	.056							
.138-32 (#6-32)	CLA	632	1	.038	.040	.213	.212	.280	.090	.27		
			2	.054	.056							
.164-32 (#8-32)	CLA	832	1	.038	.040	.234	.233	.310	.130	.28		
			2	.054	.056							
.190-24 (#10-24)	CLA	024	1	.038	.040	.296	.295	.370	.160	.31		
			2	.054	.056							
.190-32 (#10-32)	CLA	032	1	.038	.040	.296	.295	.370	.160	.31		
			2	.054	.056							
.250-20 (1/4-20)	CLA	0420	1	.054	.056	.344	.343	.440	.170	.34		
			2	.087	.091							
			3	.120	.125							

(See drawing at top of page 30) All dimensions are in millimeters.

METRIC	Thread Size x Pitch	Type		Thread Code	Shank Code	A (Shank) Max.	Min. Sheet Thickness (t)	Hole Size In Sheet +0.08	C Max.	E ±0.25	T ±0.25	Min. Dist. Hole To Edge
		Fastener Material										
		Aluminum										
M2 x 0.4	CLA	M2	1	0.98	1	4.22	4.2	6.35	1.5	4.8		
			2	1.38	1.4							
M3 x 0.5	CLA	M3	1	0.98	1	4.75	4.73	6.35	2	5.6		
			2	1.38	1.4							
M3.5 x 0.6	CLA	M3.5	1	0.98	1	5.41	5.38	7.11	2	6.9		
			2	1.38	1.4							
M4 x 0.7	CLA	M4	1	0.98	1	5.94	5.92	7.8	3	7.1		
			2	1.38	1.4							
M5 x 0.8	CLA	M5	1	0.98	1	7.52	7.49	9.4	3.8	7.9		
			2	1.38	1.4							
M6 x 1	CLA	M6	1	1.38	1.4	8.75	8.73	11.18	4.08	8.6		
			2	2.21	2.3							

(1) For maximum performance, we recommend that you use the maximum shank length for your sheet thickness.

(2) This shank code not available for SP nuts.

(3) This thread size S nut, with a -2 shank code, can be installed successfully without the need to pre punch a mounting hole in a separate operation. See page 39 for more information.



Get quote >>

Angic Global Solutions

1-888-872-0690 [www.angic.com](http://www.angic.com) 29

<https://www.AngicGlobal.com> Sales@AngicGlobal.com

# SELF-CLINCHING NUTS

**NEW**

## PEM RT® FREE-RUNNING LOCKNUTS

Free-running locking feature allows screw to turn freely until clamp load is applied. If the tightening force is removed, these nuts no longer provide any torsional resistance to rotation until clamp load is reapplied.

- Resistant to vibrational loosening.
- Back side of panel is flush or sub-flush for screw installation.
- Locking feature reusability is not affected by number of on/off cycles.
- Uses same mounting hole and installation tooling as standard S™ nuts.
- Recommended for use in steel or aluminum sheets HRB 80 / HB 150 or less.

### PART NUMBER DESIGNATION

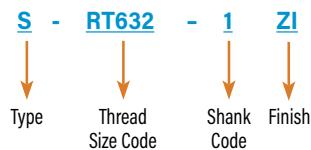

PEM RT® free-running locking feature can be added to other PEM® internally threaded nuts.

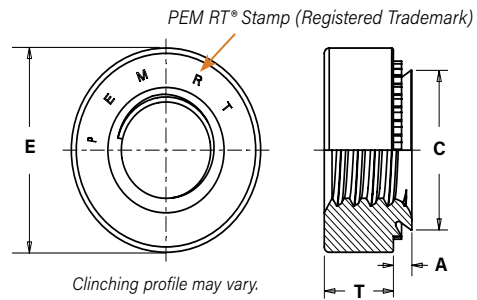

All dimensions are in inches.

UNIFIED	Thread Size	Type	Thread Code	Shank Code	A (Shank) Max.	Rec. Min. Sheet Thickness (t)	Hole Size In Sheet +.003 -.000	C Max.	E ±.010	T ±.010	Min. Dist Hole To Edge
	.112-40 (#4-40)	S	RT440	0	.030	.030	.166	.165	.250	.070	.19
1				.038	.040						
2				.054	.056						
.138-32 (#6-32)	S	RT632	0	.030	.030	.1875	.187	.280	.070	.22	
			1	.038	.040						
			2	.054	.056						
.164-32 (#8-32)	S	RT832	0	.030	.030	.213	.212	.310	.090	.27	
			1	.038	.040						
			2	.054	.056						
.190-32 (#10-32)	SS	RT032	0	.030	.030	.250	.249	.340	.090	.28	
			1	.038	.040						
			2	.054	.056						
.250-20 (1/4-20)	S	RT0420	0	.045	.047	.344	.343	.440	.170	.34	
			1	.054	.056						
			2	.087	.090						
.313-18 (5/16-18)	S	RT0518	0	.054	.056	.413	.412	.500	.230	.38	
			1	.054	.056						
			2	.087	.090						

All dimensions are in millimeters

METRIC	Thread Size x Pitch	Type	Thread Code	Shank Code	A (Shank) Max.	Rec. Min. Sheet Thickness (t)	Hole Size In Sheet +0.08	C Max.	E ±0.25	T ±0.25	Min. Dist Hole To Edge
	M3 x 0.5	S	RTM3	0	0.77	0.8	4.22	4.2	6.35	1.5	4.8
1				0.97	1						
2				1.38	1.4						
M4 x 0.7	S	RTM4	0	0.77	0.8	5.41	5.38	7.87	2	6.9	
			1	0.97	1						
			2	1.38	1.4						
M5 x 0.8	SS	RTM5	0	0.77	0.8	6.35	6.33	8.64	2	7.1	
			1	0.97	1						
			2	1.38	1.4						
M6 x 1	S	RTM6	00	0.89	0.92	8.75	8.73	11.18	4.08	8.6	
			0	1.15	1.2						
			1	1.38	1.4						
			2	2.21	2.29						
M8 x 1.25	S	RTM8	1	1.38	1.4	10.5	10.47	12.7	5.47	9.7	
			1	1.38	1.4						
			2	2.21	2.29						

(1) For maximum performance, we recommend that you use the maximum shank length for your sheet thickness.

The graph represents the clamp load of the joint versus the amount of cycles during transverse vibration testing for an PEM RT® free-running locknut, a standard S nut, a split ring lock washer and Loctite Red 271.

### Testing conditions:

- Transverse vibration testing.
- M6 thread size nuts, average of 30 pieces.
- Clamp load applied using metric property class 12.9 screws.
- Nuts tested until loss of clamp load or 2,000 cycles is reached.

Details on PEM RT® vibration resistant thread technology can be found on our web site at: [https://www.pemnet.com/files/design\\_info/techsheets/RT\\_Thread\\_Form.pdf](https://www.pemnet.com/files/design_info/techsheets/RT_Thread_Form.pdf)

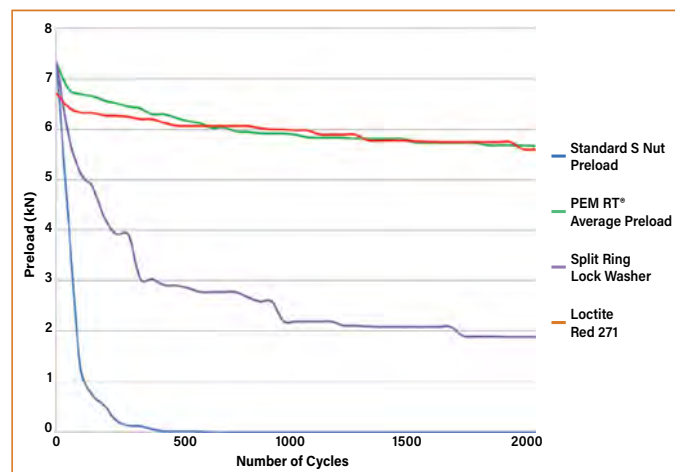

# SELF-CLINCHING NUTS

## SL™ TRI-DENT® PREVAILING TORQUE LOCKNUTS

Prevailing torque locking feature produces friction between threads of mated components thereby increasing the force needed to tighten as well as loosen the nut. Prevailing torque locknuts provide essentially the same torque value regardless of the amount axial load applied.

- 3 cycle locking performance. <sup>(1)</sup>
- Resistant to vibrational loosening.
- Back side of panel is flush or sub-flush for screw installation.
- Uses same mounting hole and installation tooling as standard S™ nuts.
- Recommended for use in sheets HRB 80 / HB 150 or less.

### PART NUMBER DESIGNATION

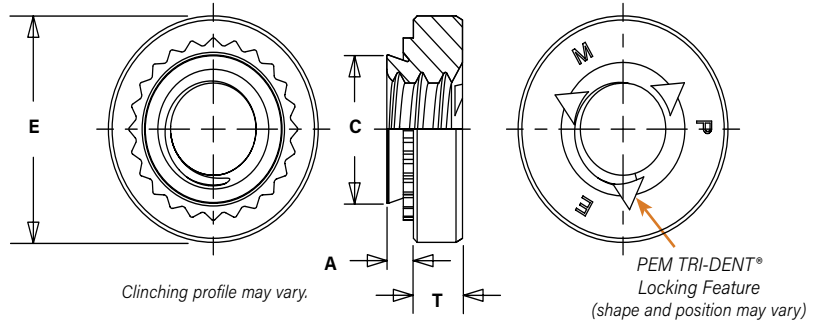
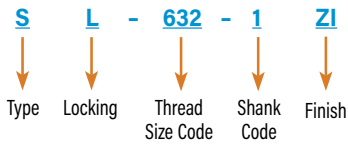

All dimensions are in inches.

UNIFIED	Thread Size	Type	Thread Code	Shank Code	A (Shank) Max.	Min. Sheet Thickness	Hole Size In Sheet +.003-.000	C Max.	E ±.010	T ±.010	Min. Dist. Hole $\varnothing$ To Edge
	.112-40 (#4-40)	SL	440	1	.038	.040	.166	.165	.250	.070	.19
				2	.054	.056					
				1	.038	.040					
				2	.054	.056					
				1	.038	.040					
				2	.054	.056					
				1	.038	.040					
				2	.087	.091					
				1	.054	.056					
				2	.087	.091					
				1	.054	.056					

All dimensions are in millimeters.

METRIC	Thread Size x Pitch	Type	Thread Code	Shank Code	A (Shank) Max.	Min. Sheet Thickness	Hole Size In Sheet +0.08	C Max.	E ±0.25	T ±0.25	Min. Dist. Hole $\varnothing$ To Edge
	M3 x 0.5	SL	M3		1	0.98	1	4.22	4.2	6.35	1.5
2					1.38	1.4					
M3.5 x 0.6	SL	M3.5		1	0.98	1	4.75	4.73	7.11	1.5	5.6
				2	1.38	1.4					
M4 x 0.7	SL	M4		1	0.98	1	5.41	5.38	7.87	2	6.9
				2	1.38	1.4					
M5 x 0.8	SL	M5		1	0.98	1	6.35	6.33	8.64	2	7.1
				2	1.38	1.4					
M6 x 1	SL	M6		1	1.38	1.4	8.75	8.73	11.18	4.08	8.6
				2	2.21	2.3					
M8 x 1.25	SL	M8		1	1.38	1.4	10.5	10.47	12.7	5.47	9.7
				2	2.21	2.3					
M10 x 1.5	SL	M10		1	2.21	2.29	14	13.97	17.35	7.48	13.5
				2	3.05	3.18					

(1) Achieved using steel socket head cap screws, 180 ksi / property class 12.9 with standard finish of thermal oxide and light oil.



Get quote >>

Angic Global Solutions

1-888-872-0690 [www.angic.com](http://www.angic.com) 31

<https://www.AngicGlobal.com> Sales@AngicGlobal.com

# SELF-CLINCHING NUTS

## H™ NUTS AND HNL™ PREVAILING TORQUE LOCKNUTS

- Meets prevailing torque requirements for IFI 100/107 Grade B (unified) and ANSI B18.16.1M (metric) locknuts.
- H nut is recommended for use in sheets HRB 80 / HB 150 or less.
- HNL nut is recommended for use in sheets HRB 60 / HB 107 or less.

### PART NUMBER DESIGNATION

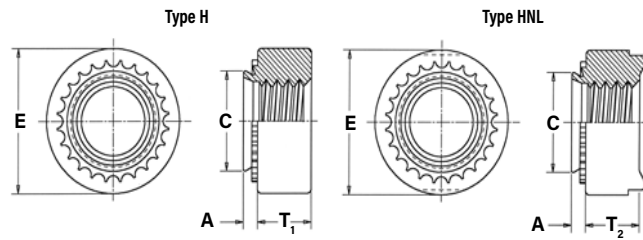
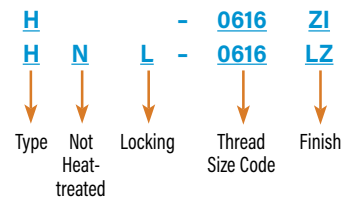

Clinching profile may vary.

All dimensions are in inches.

UNIFIED	Thread Size	Type		Thread Code	A (Shank) Max.	Min. Sheet Thickness	Hole Size In Sheet +.005 -.000	C Max.	E ±.010	T <sub>1</sub>	T <sub>2</sub>	Min. Dist. Hole $\varnothing$ To Edge
		Non-Locking	Self-Locking (1)							Non-locking	Self-locking	
										±.005	±.010	
.250-20 (1/4-20)	—	HNL	0420	.058	.058	.344	.343	.500	.189	.380		
.313-18 (5/16-18)	—	HNL	0518	.058	.058	.413	.412	.575	.240	.420		
.375-16 (3/8-16)	H	HNL	0616	.058	.058	.500	.499	.650	.300	.480		

All dimensions are in millimeters.

METRIC	Thread Size x Pitch	Type		Thread Code	A (Shank) Max.	Min. Sheet Thickness	Hole Size In Sheet +.013	C Max.	E ±0.25	T <sub>1</sub>	T <sub>2</sub>	Min. Dist. Hole $\varnothing$ To Edge
		Non-Locking	Self-Locking (1)							Non-locking	Self-locking	
										±0.13	±0.25	
M6 x 1	—	HNL	M6	1.48	1.48	8.75	8.72	12.7	5	10		
M8 x 1.25	—	HNL	M8	1.48	1.48	10.5	10.47	14.6	6.3	11		
M10 x 1.5	H	HNL	M10	1.48	1.48	12.7	12.67	16.5	7.9	12		

(1) During installation, the projections on the heads of HNL self-locking nuts may be flattened. This is not detrimental in any way and will not affect self-locking or self-clinching performance.

## SH™ HARD PANEL NUTS

- Installs into harder, high strength steel materials (high strength steel sheets up to 975MPa tensile strength).
- Hardened nut material provides stronger thread strength.

### PART NUMBER DESIGNATION

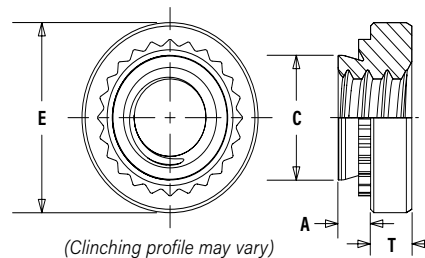
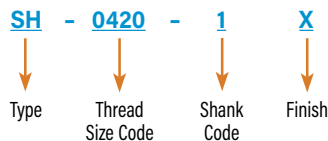

(Clinching profile may vary)  
Due to manufacturing procedure, parts may have a counterbore at shank end.

All dimensions are in inches.

UNIFIED	Thread Size	Type		Thread Code	Shank Code	A (Shank) Max.	Min. Sheet Thickness <sup>(1)</sup>	Hole Size in Sheet +.003 -.000	C Max.	E ±.010	T ±.010	Min. Dist. Hole $\varnothing$ To Edge
		Fastener Material										
		Hardened Alloy Steel										
.250-20 (1/4-20)	SH	0420	1	.054	.056	.344	.343	.440	.170	.34		
											2	.087
.313-18 (5/16-18)	SH	0518	1	.054	.056	.413	.412	.500	.230	.38		
											2	.087
.375-16 (3/8-16)	SH	0616	1	.087	.090	.500	.499	.623	.270	.44		

All dimensions are in millimeters.

METRIC	Thread Size x Pitch	Type		Thread Code	Shank Code	A (Shank) Max.	Min. Sheet Thickness <sup>(1)</sup>	Hole Size in Sheet +.008	C Max.	E ±0.25	T ±0.25	Min. Dist. Hole $\varnothing$ To Edge
		Fastener Material										
		Hardened Alloy Steel										
M6 x 1	SH	M6	1	1.38	1.4	8.75	8.73	11.8	4.08	8.6		
											2	2.21
M8 x 1.25	SH	M8	1	1.38	1.4	10.5	10.47	12.7	5.47	9.7		
											2	2.21
M10 x 1.5	SH	M10	1	2.21	2.29	14	13.97	17.35	7.48	13.5		

(1) For maximum performance, we recommend that you use the maximum shank length for your sheet thickness.

# SELF-CLINCHING NUTS

## SMPS™/SMPP™ NUTS

- Installs into sheets as thin as .025" / 0.64 mm.
- Reduced outer dimensions and thinner sheet capabilities compared to Type S/SP thread sizes.
- SMPS nut is recommended for use in sheets HRB 70 / HB 125 or less.
- SMPP nut is recommended for use in stainless steel sheets HRB 90 / HB 192 or less.

### PART NUMBER DESIGNATION

SMPS - 440  
SMPP - 440

Type                      Thread Size Code

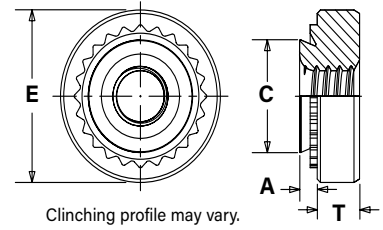

All dimensions are in inches.

UNIFIED	Thread Size	Type		Thread Code	A (Shank) Max.	Min. Sheet Thickness	Hole Size In Sheet +.003 -.000	C Max.	E ±.010	T ±.010	Min. Dist. Hole To Edge	
		Fastener Material									SMPS	SMPP
		Stainless Steel	Hardened Stainless Steel									
	.086-56 (#2-56)	SMPS	SMPP	256	.024	.025	.136	.135	.220	.065	.15	.16
	.112-40 (#4-40)	SMPS	SMPP	440	.024	.025	.166	.165	.220	.065	.17	.20
	.138-32 (#6-32)	SMPS	SMPP	632	.024	.025	.187	.186	.252	.065	.20	.22

All dimensions are in millimeters.

METRIC	Thread Size x Pitch	Type		Thread Code	A (Shank) Max.	Min. Sheet Thickness	Hole Size In Sheet +0.08	C Max.	E ±0.25	T ±0.25	Min. Dist. Hole To Edge	
		Fastener Material									SMPS	SMPP
		Stainless Steel	Hardened Stainless Steel									
	M2.5 x 0.45	SMPS	SMPP	M2.5	0.61	0.64	3.8	3.79	5.6	1.4	3.7	3.9
	M3 x 0.5	SMPS	SMPP	M3	0.61	0.64	4.24	4.22	5.6	1.4	4.3	5.1
	M3.5 x 0.6	SMPS	SMPP	M3.5	0.61	0.64	4.75	4.73	6.4	1.4	5.1	5.5

## MATERIAL AND FINISH SPECIFICATIONS

Type	Threads			Fastener Materials						Standard Finishes				Optional Finish	For use in Sheet Hardness (8)					
	Internal ASME B11.2B/ASME B11.3M, 6H	Meets Torque Requirements for I/F 100/107 Grade B (unified) and ANSI B18.16JIM (metric) Locknuts	3 Cycle Locking Performance	Hardened Carbon Steel	300 Series Stainless Steel	Aluminum	Carbon Steel	Hardened Alloy Steel	Age Hardened A286 Stainless Steel	Passivated and/or Tested per ASTM A380	Zinc Plated, per ASTM B633, SCI (5µm), Type II, Colorless (4)	Zinc Plated per ASTM B633, SCI (5µm), Type III, Colorless Plus Sealant/Lubricant (4)	No Finish (3)	Zinc Plated per ASTM B633, SCI (5µm), Type II, Yellow (1) (4)	HRC 30/ HB 277 or less	HRB 90/ HB 192 or less	HRB 80/ HB 150 or less	HRB 70/ HB 125 or less	HRB 60/ HB 107 or less	HRB 50/ HB 82 or less
S	.	.	.	.	.	.	.	.	.	.	.	.	.	.	.	.	.	.	.	.
SS	.	.	.	.	.	.	.	.	.	.	.	.	.	.	.	.	.	.	.	.
CLS	.	.	.	.	.	.	.	.	.	.	.	.	.	.	.	.	.	.	.	.
CLSS	.	.	.	.	.	.	.	.	.	.	.	.	.	.	.	.	.	.	.	.
CLA	.	.	.	.	.	.	.	.	.	.	.	.	.	. (2)	.	.	.	.	.	.
H	.	.	.	.	.	.	.	.	.	.	.	.	.	.	.	.	.	.	.	.
SP	.	.	.	.	.	.	.	.	.	.	.	.	.	.	.	.	.	.	.	.
PEM RT	. (9)	.	.	.	.	.	.	.	.	.	.	.	.	.	.	.	.	.	.	.
SL	.	.	.	.	.	.	.	.	.	.	.	.	.	.	.	.	.	.	.	.
HNL	.	.	.	.	.	.	.	.	.	.	.	.	.	.	.	.	.	.	.	.
SH	.	.	.	.	.	.	.	.	.	.	.	.	.	. (5)	.	.	.	.	.	.
SMPS	.	.	.	.	.	.	.	.	.	.	.	.	.	.	.	.	.	.	.	.
SMPP	.	.	.	.	.	.	.	.	.	.	.	.	.	.	.	.	.	.	.	.
Part number codes for finishes										None	ZI	LZ	X	ZC						

- Special order with additional charge.
- Part numbers for aluminum nuts have no plating suffix.
- Unplated threads are sized to accept a basic go gauge after .00025" / 0.0064 mm plating.
- See PEM® Technical Support section of our web site for related plating standards and specifications.
- With rust preventative oil.

- Panel material should be in the annealed condition.
- Fasteners should not be installed adjacent to bends or other highly cold-worked areas.
- HRB - Hardness Rockwell "B" Scale. HRC - Hardness Rockwell "C" Scale. HB - Hardness Brinell.
- Modified thread form on loaded flank. Will accept a maximum material 6g/2A screw.



Get quote >>

Angic Global Solutions

1-888-872-0690 [www.angic.com](http://www.angic.com) 33

<https://www.AngicGlobal.com> Sales@AngicGlobal.com

# SELF-CLINCHING NUTS

## INSTALLATION - S™/SL™/SMPS™/SS™/CLS™/CLSS™/CLA™/S-RT™/H™/HNL™ NUTS

1. Prepare properly sized mounting hole in sheet.  
Do not perform any secondary operations such as deburring.
2. Place fastener into the anvil hole and place the mounting hole (preferably the punch side) over the shank of the fastener as shown in diagram to the right.
3. With installation punch and anvil surfaces parallel, apply squeezing force until the head of the nut comes into contact with the sheet material.

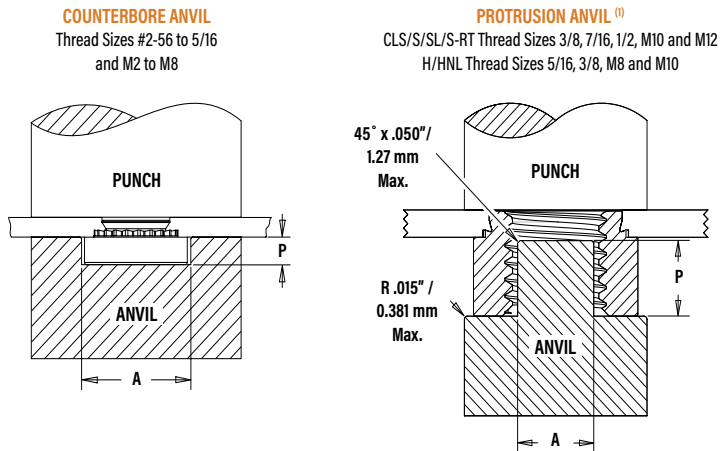

### PEMSERTER® Installation Tooling

#### CLS™/CLSS™/S™/SS™/PEM RT® NUTS

UNIFIED	Thread Code	Anvil Dimensions (in.)		Anvil Part Number	Punch Part Number
		A	P		
		±.002	±.005		
256/440/RT440	.267	.045	975200034	975200048	
632/RT632	.298	.045	975200035	975200048	
832/RT832	.330	.070	975200036	975200048	
024/032/RT032	.361	.070	975200037	975200048	
1224	.415	.080	975200786300	975200048	
0420/RT0420	.454	.150	975200038	975200048	
0518/RT0518	.517	.200	975200039	975200048	
0616	.280	.250	975200045 (1)	975200048	
0720	.338	.295	8020361 (1)	975200901400	
0813	.375	.345	975200900300 (1)	975200901400	

METRIC	Thread Code	Anvil Dimensions (mm)		Anvil Part Number	Punch Part Number
		A	P		
		±0.05	±0.13		
M2/M3/RTM3	6.78	1.14	975200034	975200048	
M3.5	7.57	1.14	975200035	975200048	
M4/RTM4	8.38	1.78	975200036	975200048	
M5/RTM5	9.17	1.78	975200037	975200048	
M6/RTM6	11.53	3.81	975200038	975200048	
M8/RTM8	13.08	5.08	975200039	975200048	
M10	7.62	6.35	8005682 (1)	975200901400	
M12	9.53	8.76	975200900300 (1)	975200901400	

#### CLA™ NUTS

UNIFIED	Thread Code	Anvil Dimensions (in.)		Anvil Part Number	Punch Part Number
		A	P		
		±.002	±.005		
256/440	.267	.045	975200034	975200048	
632	.298	.045	975200035	975200048	
832	.330	.070	975200036	975200048	
024/032	.392	.140	975200782300	975200048	
0420	.454	.150	975200038	975200048	

METRIC	Thread Code	Anvil Dimensions (mm)		Anvil Part Number	Punch Part Number
		A	P		
		±0.05	±0.13		
M3	6.78	1.14	975200034	975200048	
M3.5	7.57	1.14	975200035	975200048	
M4	8.38	1.78	975200036	975200048	
M5	9.96	3.56	975200782300	975200048	
M6	11.53	3.81	975200038	975200048	

(1) Large nut anvils use protrusion to locate part instead of counterbore.

#### SL™ NUTS

UNIFIED	Thread Code	Anvil Dimensions (in.)		Anvil Part Number	Punch Part Number
		A	P		
		±.002	±.005		
440	.267	.045	975200034	975200048	
632	.298	.045	975200035	975200048	
832	.330	.070	975200036	975200048	
032	.361	.070	975200037	975200048	
0420	.454	.150	975200038	975200048	
0518	.515	.200	975200039	975200048	

METRIC	Thread Code	Anvil Dimensions (mm)		Anvil Part Number	Punch Part Number
		A	P		
		±0.05	±0.13		
M3	6.78	1.14	975200034	975200048	
M3.5	7.57	1.14	975200035	975200048	
M4	8.38	1.78	975200036	975200048	
M5	9.17	1.78	975200037	975200048	
M6	11.53	3.81	975200038	975200048	
M8	13.08	5.08	975200039	975200048	
M10	7.62	6.35	8005682 (1)	975200901400	

#### SMPS™ NUTS

UNIFIED	Thread Code	Anvil Dimensions (in.)		Anvil Part Number	Punch Part Number
		A	P		
		±.002	±.005		
256/440	.236	.045	975200904300	975200048	
632	.267	.045	975200034	975200048	

METRIC	Thread Code	Anvil Dimensions (mm)		Anvil Part Number	Punch Part Number
		A	P		
		±0.05	±0.13		
M2.5/M3	5.99	1.14	975200904300	975200048	
M3.5	6.78	1.14	975200034	975200048	

#### H™/HNL™ NUTS

UNIFIED	Thread Code	Anvil Dimensions (in.)		Anvil Part Number	Punch Part Number
		A	P		
		±.002	±.005		
0420	.517	.200	975200039	975200048	
0518	.220	.250	975200783300 (1)	975200048	
0616	.280	.250	975201240 (1)	8003076	

METRIC	Thread Code	Anvil Dimensions (mm)		Anvil Part Number	Punch Part Number
		A	P		
		±0.05	±0.13		
M6	13.13	5.08	975200039	975200048	
M8	5.59	6.35	975200783300 (1)	975200048	
M10	7.62	6.35	8005682 (1)	8003076	

# SELF-CLINCHING NUTS

## INSTALLATION - SP™/SMPP™ NUTS (1)

1. Prepare properly sized mounting hole in sheet. Do not perform any secondary operations such as deburring.
2. Place fastener into the recommended counterbore anvil hole and place the mounting hole (preferably the punch side) over the shank of the fastener as shown in diagram.
3. With installation punch and anvil surfaces parallel, apply squeezing force until the head of the nut comes into contact with the sheet material.

### PEMSERTER® Installation Tooling

#### SP™ NUTS

UNIFIED	Thread Code	Anvil Dimensions (in.)				Anvil Part Number	Punch Part Number
		A ±.002	P +.000 -.001	R Max.	R <sub>i</sub> +.005		
	440	.255	.064	.010	.005	8012821	975200048
	632	.286	.064	.010	.005	8012822	
	832	.317	.082	.010	.005	8012823	
	024/032	.348	.082	.010	.005	8012824	8003076
	0420	.443	.163	.010	.005	8012825	
	0518	.505	.230	.010	.005	8015359	
	0616/0624	.570	.263	.010	.005	8015863	

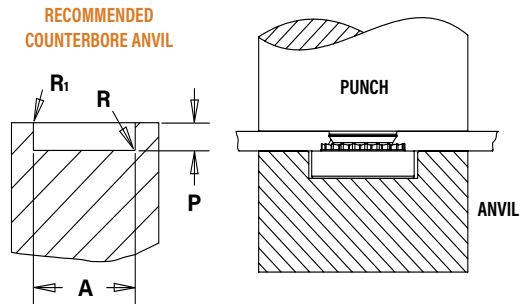

#### SMPP™ NUTS

UNIFIED	Thread Code	Anvil Dimensions (in.)				Anvil Part Number	Punch Part Number
		A ±.002	P +.000 -.001	R Max.	R <sub>i</sub> +.005		
	256	.223	.060	.010	.005	8020023	975200048
	440	.233	.060	.010	.005	8021386	
	632	.255	.060	.010	.005	8020024	

METRIC	Thread Code	Anvil Dimensions (mm)				Anvil Part Number	Punch Part Number
		A ±0.05	P -0.03	R Max.	R <sub>i</sub> +0.13		
	M2.5	5.66	1.27	0.25	0.13	8020025	975200048
	M3	5.9	1.27	0.25	0.13	8021474	
	M3.5	6.48	1.27	0.25	0.13	8020026	

(1) For best results, we recommend using the installation punch and anvil shown. Deviations from recommended installation tooling may result in sheet distortion and reduced performance.

**NOTE:** Variations in hole preparation, installation tooling, installation force, and sheet material type, thickness, and hardness will affect both performance and tooling life.

## INSTALLATION - SH™ NUTS

1. Prepare properly sized mounting hole in sheet. Do not perform any secondary operations such as deburring.
2. Place fastener into the anvil hole and place the mounting hole (preferably the punch side) over the shank of the fastener as shown in diagram to the right.
3. With installation punch and anvil surfaces parallel, apply squeezing force until the head of the nut comes into contact with the sheet material.

### PEMSERTER® Installation Tooling

UNIFIED	Thread Code	Anvil Dimensions (in.)		Anvil Part Number	Punch Part Number
		A ±.002	P ±.005		
	0420	.454	.150	975200038	975200048
	0518	.517	.200	975200039	975200048
	0616	.280	.250	8020084 <sup>(1)</sup>	9752000901400

METRIC	Thread Code	Anvil Dimensions (mm)		Anvil Part Number	Punch Part Number
		A ±0.05	P ±0.13		
	M6	11.53	3.81	975200038	975200048
	M8	13.13	5.08	975200039	975200048
	M10	7.62	6.35	8005682 <sup>(1)</sup>	9752000901400

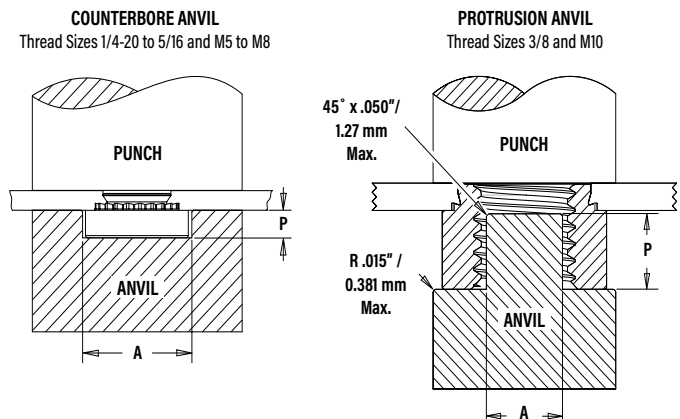

(1) Large nut anvils use protrusion to locate part instead of counterbore.

#### INSTALLATION NOTES

- For best results we recommend using a Haeger® or PEMSERTER® press for installation of PEM® self-clinching fasteners. Please check our website for more information.
- Visit the Animation Library on our website to view the installation process [for select products](#).



Get quote >>

Angic Global Solutions

1-888-872-0690 [www.angic.com](http://www.angic.com) 35

<https://www.AngicGlobal.com> Sales@AngicGlobal.com

# SELF-CLINCHING NUTS

## PERFORMANCE DATA<sup>(1)</sup>

Axial Strength and Mating Screw Recommended Tightening Torque data is available at:  
[www.pemnet.com/design\\_info/tightening-torque/](http://www.pemnet.com/design_info/tightening-torque/)

### S™/CLS™/CLSS™ NUTS

Type	Thread Code	Shank Code	Test Sheet Material <sup>(2)</sup>	Installation (lbs.)	Pushout (lbs.)	Torque-out (in. lbs.)	
S CLS	256 348 440	0	5052-H34 Aluminum	1500-2000	63	8	
		1			90	10	
		2			170	13	
		3			170	13	
		0	Cold-rolled Steel		105	13	
		1			125	15	
		2			230	18	
3	230	18					
S CLS	632	0	5052-H34 Aluminum	2500-3000	63	16	
		1			95	17	
		2			190	22	
		3			190	22	
		0	Cold-rolled Steel		110	16	
		1			130	20	
		2			275	28	
3	275	28					
S CLS	832	0	5052-H34 Aluminum	2500-3000	68	21	
		1			105	23	
		2			220	35	
		3			220	35	
		0	Cold-rolled Steel		110	26	
		1			145	35	
		2			285	45	
3	285	45					
SS CLSS	024 032	0	5052-H34 Aluminum	2500-3500	68	26	
		1			110	32	
		2			190	50	
		3			225	50	
		0	Cold-rolled Steel		120	32	
		1			180	40	
		2			320	60	
3	320	60					
S CLS	1224	1	5052-H34 Aluminum	2500-6500	120	63	
		2			285	70	
		3			285	70	
		1			Cold-rolled Steel	200	74
		2	350			80	
		3	350			80	
		S CLS	0420		0	5052-H34 Aluminum	4000-7000
1	360			90			
2	360			125			
3	360			125			
0	Cold-rolled Steel			315	115		
1				6000-8000	400	150	
2					400	150	
3	400	150					
S CLS	0518 0524	1	5052-H34 Aluminum	4000-7000	120	120	
		2			160	160	
		3			160	160	
		1	Cold-rolled Steel		165	165	
2	180	180					
3	180	180					
S CLS	0616 0624	1	5052-H34 Aluminum	5000-8000	400	270	
		2			400	270	
		3			400	270	
		1	Cold-rolled Steel		460	320	
2	460	320					
3	460	320					
S	0720	1	Cold-rolled Steel	9000-13000	450	340	
S CLS	0813 0820	1	5052-H34 Aluminum	7000-9000	475	350	
		2			475	350	
		1	Cold-rolled Steel		1050	735	
2	1050	735					

Type	Thread Code	Shank Code	Test Sheet Material <sup>(2)</sup>	Installation (kN)	Pushout (N)	Torque-out (N-m)	
S CLS	M2 M2.5 M3	0	5052-H34 Aluminum	6.7-8.9	280	0.9	
		1			400	1.13	
		2			750	1.47	
		0	Cold-rolled Steel		470	1.47	
		1			550	1.7	
		2			1010	2.03	
S CLS	M3.5	0	5052-H34 Aluminum	11.2-13.5	280	1.8	
		1			400	1.92	
		2			840	2.5	
		0	Cold-rolled Steel		480	1.8	
		1			570	2.3	
2	1210	2.3					
S CLS	M4	0	5052-H34 Aluminum	11.2-13.4	300	2.37	
		1			470	2.6	
		2			970	4	
		0	Cold-rolled Steel		490	2.95	
		1			645	4	
		2			1250	5.1	
SS CLSS	M5	0	5052-H34 Aluminum	11.2-15.6	300	3	
		1			480	3.6	
		2			845	5.7	
		0	Cold-rolled Steel		530	3.6	
		1			800	4.5	
		2			1420	6.8	
S CLS	M6	00	5052-H34 Aluminum	18-32	750	6.5	
		0			970	7.9	
		1			1580	10.2	
		2			14.1	14.1	
		00			Cold-rolled Steel	900	10
		0	1380			13	
		1	1760			17	
		2	1760			17	
		1	5052-H34 Aluminum			18-32	1570
		2			1870	18.1	
1	27-36	1870		18.7			
2	27-36	1870	20.3				
S CLS	M10	1	5052-H34 Aluminum	22-36	1760	32.7	
		2			1760	32.7	
		1	Cold-rolled Steel		32-50	2020	36.2
		2			32-50	2020	36.2
S	M12	1	5052-H34 Aluminum	31-40	2113	39.5	
		1	Cold-rolled Steel	44-67	4670	83.1	

### CLA™ NUTS

Type	Thread Code	Shank Code	Test Sheet Material	Installation (lbs.)	Pushout (lbs.)	Torque-out (in. lbs.)
CLA	440	1	5052-H34 Aluminum	800 - 1500	100	6
		2	5052-H34 Aluminum	800 - 1500	120	9
CLA	632	1	5052-H34 Aluminum	1000 - 1500	110	21
		2	5052-H34 Aluminum	1200 - 1700	155	24
CLA	832	1	5052-H34 Aluminum	1000 - 1500	120	27
		2	5052-H34 Aluminum	1300 - 1800	170	29
CLA	032	1	5052-H34 Aluminum	1700 - 2200	130	34
		2	5052-H34 Aluminum	2600 - 3100	200	50

Type	Thread Code	Shank Code	Test Sheet Material	Installation (kN)	Pushout (N)	Torque-out (N-m)
CLA	M2	2	5052-H34 Aluminum	3.56 - 6.67	500	0.4
CLA	M3	1	5052-H34 Aluminum	3.56 - 6.67	445	0.68
		2	5052-H34 Aluminum	3.56 - 6.67	534	1.02
CLA	M4	1	5052-H34 Aluminum	4.45 - 6.67	534	3.05
		2	5052-H34 Aluminum	5.78 - 8.01	756	3.27

(1) Published installation forces are for general reference. Actual set-up and confirmation of complete installation should be made by observing proper seating of fastener as described in the installation steps. Other performance values reported are averages when all proper installation parameters and procedures are followed. Variations in mounting hole size, sheet material, and installation procedure may affect performance. Performance testing this product in your application is recommended. We will be happy to provide technical assistance and/or samples for this purpose.

(2) See [tech sheet](#) on our website for performance data of PEM® Type S™ nuts installed into copper sheets.

# SELF-CLINCHING NUTS

## PERFORMANCE DATA

Axial Strength and Mating Screw Recommended Tightening Torque data is available at: [www.pemnet.com/design\\_info/tightening-torque/](http://www.pemnet.com/design_info/tightening-torque/)

### PEM RT® NUTS

Type	Thread Code	Shank Code	Test Sheet Material	Installation (lbs.)	Pushout (lbs.)	Torque-out (in. lbs.)
S	RT440	0	5052-H34 Aluminum	1500-2000	63	8
		1			90	10
		2			170	13
		0	Cold-rolled Steel	2500-3500	105	13
		1			125	15
		2			230	18
S	RT632	0	5052-H34 Aluminum	2500-3000	63	16
		1			95	17
		2			190	22
		0	Cold-rolled Steel	3000-6000	110	16
		1			130	20
		2			275	28
S	RT832	0	5052-H34 Aluminum	2500-3000	68	21
		1			105	23
		2			220	35
		0	Cold-rolled Steel	4000-6000	110	26
		1			145	35
		2			285	45
SS	RT032	0	5052-H34 Aluminum	2500-3500	68	26
		1			110	32
		2			190	50
		0	Cold-rolled Steel	4000-9000	120	32
		1			180	40
		2			320	60
S	RT0420	0	5052-H34 Aluminum	4000-7000	220	70
		1			360	90
		2			360	125
		0	Cold-rolled Steel	6000-8000	315	115
		1			400	150
		2				
S	RT0518	1	5052-H34 Aluminum	4000-7000	380	120
		2			160	
		1	Cold-rolled Steel	6000-8000	420	165
		2			180	

Type	Thread Code	Shank Code	Test Sheet Material	Installation (kN)	Pushout (N)	Torque-out (N-m)
S	RTM3	0	5052-H34 Aluminum	6.7-8.9	280	0.9
		1			400	1.13
		2			750	1.47
		0	Cold-rolled Steel	11.2-15.6	470	1.47
		1			550	1.7
		2			1010	2.03
S	RTM4	0	5052-H34 Aluminum	11.2-13.4	300	2.37
		1			470	2.6
		2			970	4
		0	Cold-rolled Steel	18-27	490	2.95
		1			645	4
		2			1250	5.1
SS	RTM5	0	5052-H34 Aluminum	11.2-15.6	300	3
		1			480	3.6
		2			845	5.7
		0	Cold-rolled Steel	18-38	530	3.6
		1			800	4.5
		2			1420	6.8
S	RTM6	00	5052-H34 Aluminum	18-32	750	6.5
		0			970	7.9
		1			1580	10.2
		2	Cold-rolled Steel	27-36	14.1	
		00			900	10
		0			1380	13
1		1760	17			
S	RTM8	1	5052-H34 Aluminum	18-32	1690	13.6
		2			18.1	
		1	Cold-rolled Steel	27-36	1865	18.7
		2			20.3	

### SL™ NUTS

Thread Code	Shank Code	Prevailing Torque Specifications (1)		Test Sheet Material					
		Max. Torque (1st thru 3rd) (in. lbs.)	Min. Torque (1st thru 3rd) (in. lbs.)	5052-H34 Aluminum			Cold-rolled Steel		
				Installation (lbs.)	Pushout (lbs.)	Torque-out (in. lbs.)	Installation (lbs.)	Pushout (lbs.)	Torque-out (in. lbs.)
440	1	5.75	0.4	1500 - 2000	90	10	2500 - 3500	125	15
	2				170	13		230	18
632	1	10.5	0.8	2500 - 3000	95	17	3000 - 6000	130	20
	2				190	22		275	28
832	1	18	1.2	2500 - 3000	105	23	4000 - 6000	145	35
	2				220	35		285	45
032	1	21	1.65	2500 - 3000	110	32	4000 - 9000	180	40
	2				190	50		250	60
0420	1	35	3.75	4000 - 7000	360	90	6000 - 9000	400	150
	2				360	125		400	150
0518	1	53	4.75	4000 - 7000	380	120	6000 - 8000	420	165
	2				380	160		420	180

Thread Code	Shank Code	Prevailing Torque Specifications (1)		Test Sheet Material					
		Max. Torque (1st thru 3rd) (N-m)	Min. Torque (1st thru 3rd) (N-m)	5052-H34 Aluminum			Cold-rolled Steel		
				Installation (kN)	Pushout (N)	Torque-out (N-m)	Installation (kN)	Pushout (N)	Torque-out (N-m)
M3	1	0.67	0.04	6.7 - 8.9	400	1.13	11.2 - 15.6	550	1.7
	2				750	1.47		1010	2.03
M3.5	1	1.2	0.08	11.2 - 13.5	400	1.92	13.4 - 26.7	570	2.3
	2				840	2.5		1210	2.3
M4	1	2.1	0.13	11.2 - 13.4	470	2.6	18 - 27	645	4
	2				970	4		1250	5.1
M5	1	2.4	0.18	11.2 - 15.6	480	3.6	18 - 38	800	4.5
	2				845	5.7		1112	6.8
M6	1	4	0.3	18 - 32	1580	10.2	27 - 36	1760	17
	2				1580	14.1		1760	17
M8	1	6	0.5	18 - 32	1570	13.6	27 - 36	1870	18.7
	2				1570	18.1		1870	20.3
M10	1	12	0.8	22 - 36	1760	32.7	32 - 50	2020	36.2
	2				1760	32.7		2020	36.2

(1) 3 cycle locking performance. Max. on / Min. off torque for 1st through 3rd cycles.



Get quote »

Angic Global Solutions

1-888-872-0690 [www.angic.com](http://www.angic.com) 37

<https://www.AngicGlobal.com> Sales@AngicGlobal.com

# SELF-CLINCHING NUTS

## PERFORMANCE DATA

Axial Strength and Mating Screw Recommended Tightening Torque data is available at: [www.pemnet.com/design\\_info/tightening-torque/](http://www.pemnet.com/design_info/tightening-torque/)

### SP™ NUTS

UNIFIED	Type	Thread Code	Shank Code	Test Sheet Material	Installation (lbs.)	Pushout (lbs.)	Torque-out (in. lbs.)
	SP	256	0 1 2	304 Stainless Steel	8000 9000 10000	130 165 290	14 17 18
SP	440	0 1 2	304 Stainless Steel	8000 9000 10000	130 165 290	14 17 18	
SP	632	0 1 2	304 Stainless Steel	8500 9500 10500	140 170 340	18 24 28	
SP	832	0 1 2	304 Stainless Steel	9000 10000 11000	145 180 360	30 37 45	
SP	024/032	0 1 2	304 Stainless Steel	9500 10500 11500	180 230 400	35 45 60	
SP	0420	1 2	304 Stainless Steel	13500 13500	450 600	150 170	
SP	0518	1 2	304 Stainless Steel	14800 14800	470 750	170 250	
SP	0524	1 2	304 Stainless Steel	14800 14800	470 750	170 250	
SP	0616/0624	1 2	304 Stainless Steel	16000 20000	600 700	300 370	

METRIC	Type	Thread Code	Shank Code	Test Sheet Material	Installation (kN)	Pushout (N)	Torque-out (N-m)
	SP	M2	1 2	304 Stainless Steel	40 44.5	725 1290	1.92 2.03
SP	M2.5	0 1 2	304 Stainless Steel	35.6 40 44.5	575 725 1290	1.58 1.92 2.03	
SP	M3	0 1 2	304 Stainless Steel	35.6 40 44.5	575 725 1290	1.58 1.92 2.03	
SP	M4	0 1 2	304 Stainless Steel	40 44.5 49	645 800 1600	3.38 4.18 5.08	
SP	M5	0 1 2	304 Stainless Steel	42.3 46.7 51.2	800 1025 1775	3.95 5.08 6.77	
SP	M6	1 2	304 Stainless Steel	60 60	2000 2600	17 19	
SP	M8	1 2	304 Stainless Steel	66 80	2100 4500	19 23	
SP	M10	1	304 Stainless Steel	80	2150	38	

### H™ NUTS

UNIFIED	Type	Thread Code	Test Sheet Thickness and Sheet Material	Installation (lbs.)	Pushout (lbs.)	Torque-out (in. lbs.)
	H	0616	.090" 5052-H34 Aluminum .088" Cold-rolled Steel	4900 7400	380 460	190 240

METRIC	Type	Thread Code	Test Sheet Thickness and Sheet Material	Installation (kN)	Pushout (N)	Torque-out (N-m)
	H	M10	2.29 mm 5052-H34 Aluminum 2.24 mm Cold-rolled Steel	22 33	1760 2020	21.5 27.1

### SH™ NUTS

UNIFIED	Thread Code	Shank Code	Test Sheet Thickness and Material (in.)	Sheet Hardness HRC	Installation (lbs.)	Pushout (lbs.)	Torque-out (in. lbs.)
	0420	1 2	.098" S700MC	23	11700 12900	950 1000	150 170
0518	1 2	.098" S700MC	23	12600 12900	1050 1100	265 265	
0616	1	.098" S700MC	23	15300	1200	500	

METRIC	Thread Code	Shank Code	Test Sheet Thickness and Material (mm)	Sheet Hardness HRC	Installation (kN)	Pushout (N)	Torque-out (N-m)
	M6	1 2	2.5 mm S700MC	23	52.1 57.4	4200 4500	17 19
M8	1 2	2.5 mm S700MC	23	56.1 57.4	4600 4900	30 30	
M10	1	2.5 mm S700MC	23	71.2	5400	56	



# SELF-CLINCHING NUTS

## PERFORMANCE DATA

Axial Strength and Mating Screw Recommended Tightening Torque data is available at: [www.pemnet.com/design\\_info/tightening-torque/](http://www.pemnet.com/design_info/tightening-torque/)

### SMPS™ NUTS

UNIFIED	Type	Thread Code	Test Sheet Material		
			Cold-rolled Steel		
			Installation (lbs.)	Pushout (lbs.)	Torque-out (in. lbs.)
SMPS	256	1500	35	8	
SMPS	440	1800	60	12	
SMPS	632	2000	65	14	

METRIC	Type	Thread Code	Test Sheet Material		
			Cold-rolled Steel		
			Installation (kN)	Pushout (N)	Torque-out (N-m)
SMPS	M2.5	6.7	156	1.13	
SMPS	M3	8	267	1.35	
SMPS	M3.5	8.8	289	1.58	

### SMPP™ NUTS

UNIFIED	Type	Thread Code	Test Sheet Material		
			.029" 304 Stainless Steel HRB 89		
			Installation <sup>(1)</sup> (lbs.)	Pushout (lbs.)	Torque-out (in. lbs.)
SMPP	256	4500	50	10	
SMPP	440	4500	75	15	
SMPP	632	6000	75	20	

METRIC	Type	Thread Code	Test Sheet Material		
			0.7 mm 304 Stainless Steel HRB 89		
			Installation <sup>(1)</sup> (kN)	Pushout (N)	Torque-out (N-m)
SMPP	M2.5	20	200	1.35	
SMPP	M3	20	300	1.85	
SMPP	M3.5	27	300	1.9	

(1) Installation controlled by proper cavity depth in installation tooling.

## PUSHOUT TEST

Pushout tests shall be performed from the grip or shank side of the installed fastener. An axial load shall be applied to the fastener as shown using a hardened test screw, while evenly supporting the test strip around the fastener. The typical position rate is .25" / 6.35 mm per minute. Dimensions are identified per PEM Bulletins where "E" equals head diameter and "T" (or "L") equals head height. The pushout force is measured using a force or compression tester with a range that will cover the expected forces.

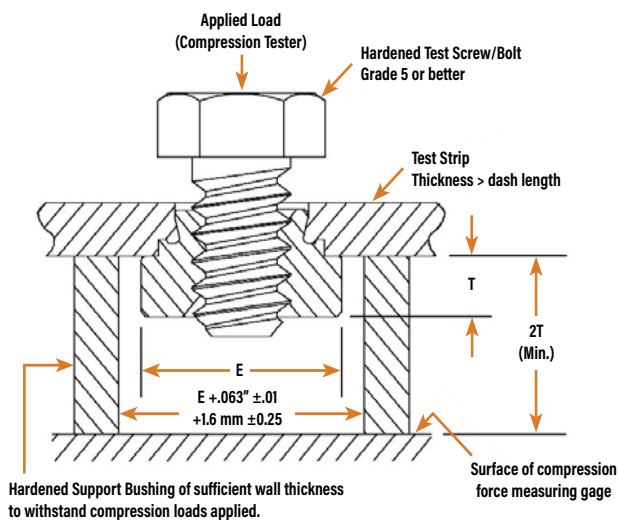

## TORQUE-OUT TEST

Torque-out tests shall be performed from the shoulder or head side of the installed fastener. Torque shall be applied to the fastener in the manner illustrated, using a hardened test screw and washer, while firmly holding the test strip. Test screws should be of sufficient tensile strength to resist thread stripping. A minimum of two screw threads must extend beyond the fastener.

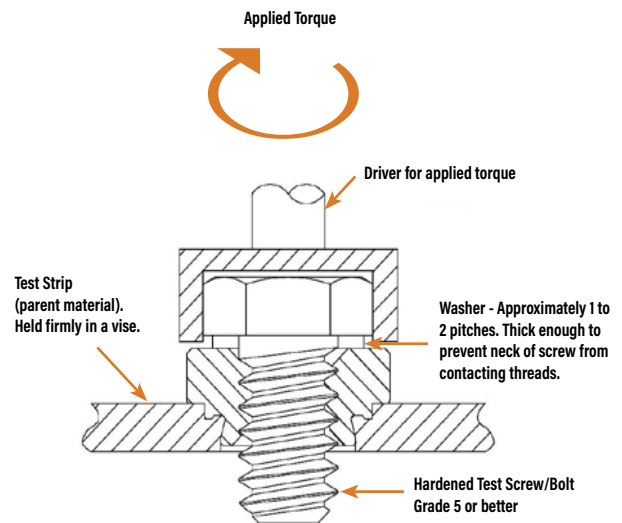

# SELF-CLINCHING NUTS

## SELF-PIERCING, SELF-CLINCHING TOOLING

Specialized PEMSERTER® tooling allows installation of S self-clinching nuts into aluminum sheets (sizes 1/4", 5/16", M6 and M8) in one pierce/press operation.

For more information, see our web site for Tech Sheet [PEM® - Ref / Self-piercing, self-clinching tooling](#).  
To locate, simply type "self-piercing" in site search box.

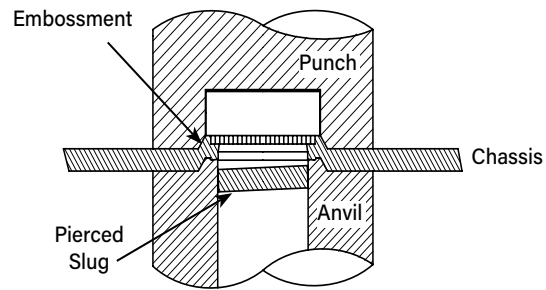

## SELF-CLINCHING NUT INSTALLATION DOS AND DON'TS

### "DOS"

- DO** select the proper fastener material to meet corrosion requirements.
- DO** make certain that panel material is in the annealed condition.
- DO** make certain that hole punch is kept sharp to minimize work hardening around hole.
- DO** provide mounting hole of specified size for each fastener.
- DO** maintain the hole punch diameter to no greater than +.001"/.025 mm over the minimum recommended mounting hole for type SP nuts into stainless steel sheets.
- DO** install fastener into hole punch side of sheet.
- DO** make certain that shank (or pilot) is within hole before applying installation force.
- DO** make certain that fastener is not installed adjacent to bends or other highly cold-worked areas.
- DO** apply squeezing force between parallel surfaces.
- DO** utilize recommended installation tooling when installing fasteners.
- DO** apply sufficient force to totally embed clinching ring around entire circumference and to bring shoulder squarely in contact with sheet.

### "DON'TS"

- DON'T** attempt to install any self-clinching nut other than types SP/SMPP fasteners into a stainless steel sheet.
- DON'T** install steel or stainless steel fasteners in aluminum panels before anodizing or finishing.
- DON'T** deburr mounting holes on either side of sheet before installing fasteners – deburring will remove metal required for clinching fastener into sheet.
- DON'T** install fastener closer to edge of sheet than minimum edge distance indicated by manufacturer – unless a special fixture is used to restrict bulging of sheet edge.
- DON'T** over-squeeze. It will crush the head, distort threads, and buckle the sheet. Approximate installation forces are listed in performance data tables. Use this info as a guide. Be certain to determine optimum installation force by test prior to production runs.
- DON'T** attempt to insert fastener with a hammer blow – under any circumstances. A hammer blow won't permit the sheet metal to flow and develop an interlock with the fastener's contour.
- DON'T** install screw in the head side of fastener. Install from opposite side so that the fastener load is toward sheet. The clinching force is designed only to hold the fastener during handling and to resist torque during assembly.
- DON'T** install fastener on pre-painted side of panel.



PEM® self-clinching flush nuts are flush with both sides of the sheet.

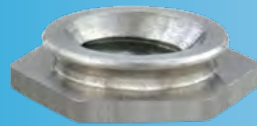

**F**<sup>TM</sup>

**PEMSERT®  
SELF-CLINCHING  
FASTENERS**

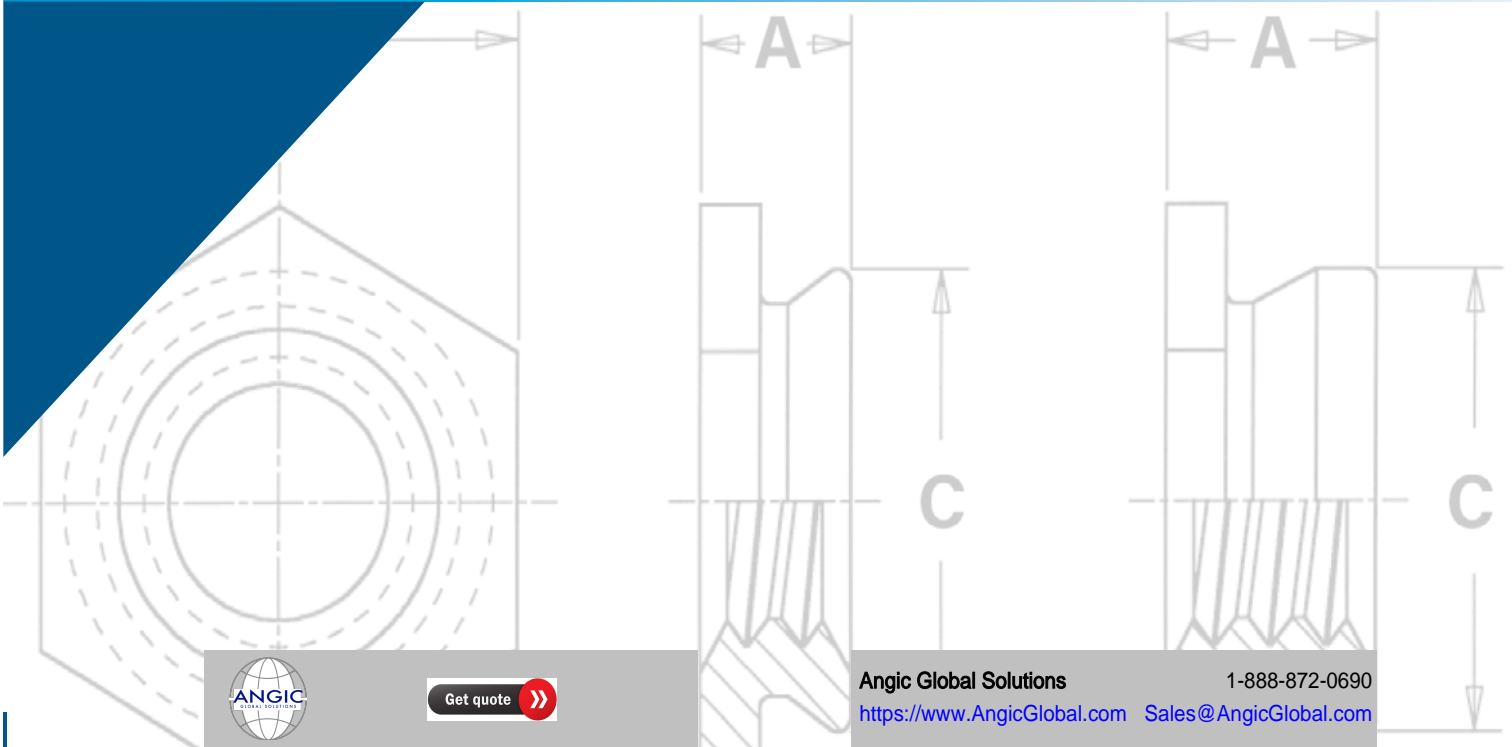

Get quote >>

Angic Global Solutions

1-888-872-0690

<https://www.AngicGlobal.com> [Sales@AngicGlobal.com](mailto:Sales@AngicGlobal.com)

# PEMSERT® SELF-CLINCHING FLUSH FASTENERS

**PEMSERT® self-clinching flush nuts are designed to be installed into sheets as thin as .060"/1.5 mm.**

F™ and F4™ fasteners are ideal for applications where a thin sheet requires threads stronger than a tapped hole but still must remain flat, with no protrusions on either surface, enhancing the functional and cosmetic qualities of the entire assembly.

PEMSERT® flush nuts are installed easily by squeezing them into a round hole in metal sheets. They can be installed before bending and forming to provide threads in places which would be inaccessible for installation after chassis are formed. The hexagonal head along with the proven PEM® self-clinching design ensures high axial and torsional strength.



F4™ flush nuts are specifically designed to be installed into stainless steel sheets.

PEMSERT® F™ fasteners can be ordered to conform to US NASM45938/4 specifications.\*

*\*To meet national aerospace standards and to obtain testing documentation, product must be ordered to NASM45938/4 specifications. Consult our Marketing department for a complete Military Specification and National Aerospace Standards Reference Guide (Bulletin NASM) or check our web site.*

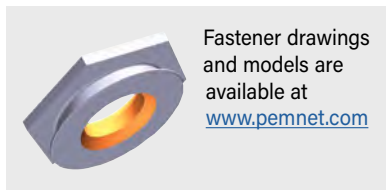

Fastener drawings  
and models are  
available at  
[www.pemnet.com](http://www.pemnet.com)

## A NOTE ABOUT HARDENED 400 SERIES STAINLESS STEEL

In order for self-clinching fasteners to work properly, the fastener must be harder than the sheet into which it is being installed. In the case of stainless steel panels, fasteners made from 300 Series Stainless Steel do not meet this hardness criteria. It is for this reason that 400 series F4™ fasteners are offered. However, while these 400 Series fasteners install and perform well in 300 Series stainless sheets they should not be used if the end product:

- Will be exposed to any appreciable corrosive environment.
- Requires non-magnetic fasteners.
- Will be exposed to any temperatures above 300° F (149° C)

If any of these are issues, please contact [techsupport@pemnet.com](mailto:techsupport@pemnet.com) for other options.

# PEMSERT® SELF-CLINCHING FLUSH FASTENERS

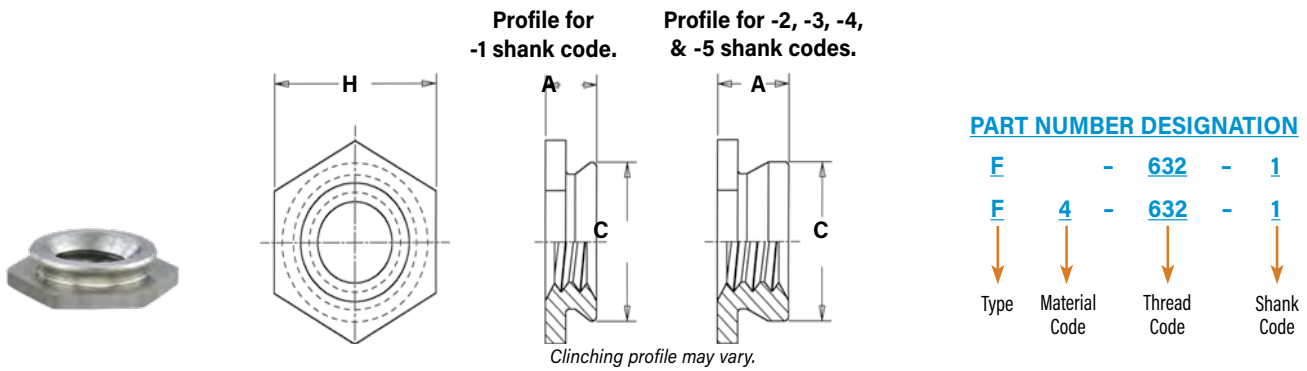

All dimensions are in inches.

UNIFIED	Thread Size	Type		Thread Code	Shank Code	A (Shank) Max.	Sheet Thickness	Hole Size In Sheet +.003 -.000	C Max.	H Nom.	Min. Dist. Hole $\varnothing$ To Edge
		Fastener Material									
		Stainless Steel	Hardened Stainless Steel								
.086-56 (#2-56)	F	F4	256	1	.060	.060 - .091	.172	.171	.188	.23	
				2	.090	.091 Min.					
.112-40 (#4-40)	F	F4	440	1	.060	.060 - .091	.172	.171	.188	.23	
				2	.090	.091 Min.					
.138-32 (#6-32)	F	F4	632	1	.060	.060 - .091	.213	.212	.250	.27	
				2	.090	.091 Min.					
.164-32 (#8-32)	F	F4	832	1	.060	.060 - .091	.290	.289	.312	.28	
				2	.090	.091 Min.					
.190-32 (#10-32)	F	F4	032	1	.060	.060 - .091	.312	.311	.343	.31	
				2	.090	.091 Min.					
.250-20 (1/4-20)	F	F4	0420	3	.120	.125 - .156	.344	.343	.375	.34	
				4	.151	.156 - .187					
				5	.182	.187 Min.					

All dimensions are in millimeters.

METRIC	Thread Size	Type		Thread Code	Shank Code	A (Shank) Max.	Sheet Thickness	Hole Size In Sheet +0.08	C Max.	H Nom.	Min. Dist. Hole $\varnothing$ To Edge
		Fastener Material									
		300 Series Stainless Steel	Hardened Stainless Steel								
M2 x 0.4	F	F4	M2	1	1.53	1.53 - 2.32	4.37	4.35	4.8	6	
				2	2.3	2.32 Min.					
M2.5 x 0.45	F	F4	M2.5	1	1.53	1.53 - 2.32	4.37	4.35	4.8	6	
				2	2.3	2.32 Min.					
M3 x 0.5	F	F4	M3	1	1.53	1.53 - 2.32	4.37	4.35	4.8	6	
				2	2.3	2.32 Min.					
M4 x 0.7	F	F4	M4	1	1.53	1.53 - 2.32	7.37	7.35	7.9	7.2	
				2	2.3	2.32 Min.					
M5 x 0.8	F	F4	M5	1	1.53	1.53 - 2.32	7.92	7.9	8.7	8	
				2	2.3	2.32 Min.					
M6 x 1	F	F4	M6	3	3.05	3.18 - 3.96	8.74	8.72	9.5	8.8	
				4	3.84	3.96 - 4.75					
				5	4.63	4.75 Min.					

## MATERIAL AND FINISH SPECIFICATIONS

Type	Threads	Fastener Materials		Standard Finish	For Use in Sheet Hardness: (1)	
	Internal, ASME B1.1, 2B / ASME B1.13M, 6H	300 Series Stainless Steel	Hardened 400 Series Stainless Steel	Passivated and/or Tested Per ASTM A380	HRB 88 / HB 183 or less	HRB 70 / HB 125 or less
F	▪	▪		▪		▪
F4	▪		▪	▪	▪	
Part Number Code For Finishes				None		

(1) HRB - Hardness Rockwell "B" Scale. HB - Hardness Brinell.



Get quote »

Angic Global Solutions

1-888-872-0690 [www.angic.com](http://www.angic.com) 43

<https://www.AngicGlobal.com> Sales@AngicGlobal.com

# PEMSERT® SELF-CLINCHING FLUSH FASTENERS

## INSTALLATION

1. Prepare properly sized round mounting hole in sheet. Do not perform any secondary operations such as deburring.
2. Place fastener onto the anvil and place the mounting hole (preferably the punch side) over the shank of the fastener as shown in the drawing.
3. With installation punch and anvil surfaces parallel, apply sufficient squeezing force only to embed hexagonal head flush in sheet. The metal displaced by the head flows evenly and smoothly around the back-tapered shank of the fastener, securely locking it into place with high pullout resistance while at the same time, the embedded hexagonal head provides high torque resistance.

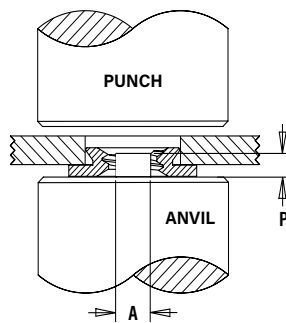

## PEMSERTER® Installation Tooling

Thread Code	Anvil Dimensions		Anvil Part Number	Punch Part Number
	A	P		
256/M2/M2.5	.060" / 1.52mm	.050" / 1.27mm	8006193	975200048
440/M3	.077" / 1.96mm	.050" / 1.27mm	975200040	
632	.092" / 2.34mm	.050" / 1.27mm	975200041	
832/M4	.124" / 3.15mm	.050" / 1.27mm	975200042	
032/M5	.139" / 3.53mm	.050" / 1.27mm	975200043	
0420/M6	.186" / 4.72mm	.100" / 2.54mm	975200044	

### INSTALLATION NOTES

- For best results we recommend using a Haeger® or PEMSERTER® machine for installation of PEM® self-clinching fasteners. Please check our [website](#) for more information.
- Visit the Animation Library on our website to view the installation process [for this product](#).

## PERFORMANCE DATA<sup>(1)</sup>

### F™ NUTS

UNIFIED	Thread Code	Shank Code	Axial Tensile Strength (lbs.) (2)	Rec. Tightening Torque (3) (in. lbs.)	Test Sheet Material							
					5052-H34 Aluminum		Cold-rolled Steel					
					Installation (lbs.)	Pushout (lbs.)	Installation (lbs.)	Pushout (lbs.)				
256	1	2	130	1.50	2000	150	3000	200				
440	1	2	165	2.50	2000	150	3000	200				
632	1	2	190	3.50	2000	200	3600	200				
832	1	2	230	5.25	2000	240	4000	240				
032	1	2	280	7.50	2500	240	5000	240				
0420	3	4	1035	36	3500	640	6000	840				

METRIC	Thread Code	Shank Code	Axial Tensile Strength (kN) (2)	Rec. Tightening Torque (3) (N-m)	Test Sheet Material							
					5052-H34 Aluminum		Cold-rolled Steel					
					Installation (kN)	Pushout (N)	Installation (kN)	Pushout (N)				
M2	1	2	0.57	0.16	8.9	665	13.3	890				
M2.5	1	2	0.68	0.23	8.9	665	13.3	890				
M3	1	2	0.85	0.36	8.9	665	13.3	890				
M4	1	2	1	0.58	8.9	1068	17.8	1068				
M5	1	2	1.3	0.88	11.1	1068	22.2	1068				
M6	3	4	4.5	3.7	15.6	2847	26.7	3736				

### F4™ NUTS

UNIFIED	Thread Code	Shank Code	Axial Tensile Strength (lbs.) (2)	Rec. Tightening Torque (3) (in. lbs.)	Test Sheet Material			
					300 Series Stainless Steel			
					Installation (lbs.)	Pushout (lbs.)		
256	1	2	130	1.50	7200	270		
440	1	2	165	2.50	7200	270		
632	1	2	190	3.50	7200	290		
832	1	2	230	5.25	9000	450		
032	1	2	280	7.50	9000	450		
0420	3	4	1035	36	14000	1000		

METRIC	Thread Code	Shank Code	Axial Tensile Strength (kN) (2)	Rec. Tightening Torque (3) (N-m)	Test Sheet Material			
					300 Series Stainless Steel			
					Installation (kN)	Pushout (N)		
M2	1	2	0.57	0.16	32	1200		
M2.5	1	2	0.68	0.23	32	1200		
M3	1	2	0.85	0.36	32	1200		
M4	1	2	1	0.58	40	2000		
M5	1	2	1.3	0.88	40	2000		
M6	3	4	4.5	3.7	65	4500		

- (1) Published installation forces are for general reference. Actual set-up and confirmation of complete installation should be made by observing proper seating of fastener as described in the installation steps. Other performance values reported are averages when all proper installation parameters and procedures are followed. Variations in mounting hole size, sheet material, and installation procedure may affect performance. Performance testing this product in your application is recommended. We will be happy to provide technical assistance and/or samples for this purpose.
- (2) Failure occurs in screw stripping using a 60 ksi screw and the shortest shank length fastener.
- (3) Torque values shown will produce a preload of 70% of axial tensile strength with nut factor "k" equal to .2. Threads may strip or head of the F nut may bend and/or fail if screw is over-torqued beyond these values or if actual k value is less than .2.



PEM® brand miniature fasteners fit into a minimal space and provide strong, reusable threads.



**FE™**

## MINIATURE SELF-CLINCHING FASTENERS

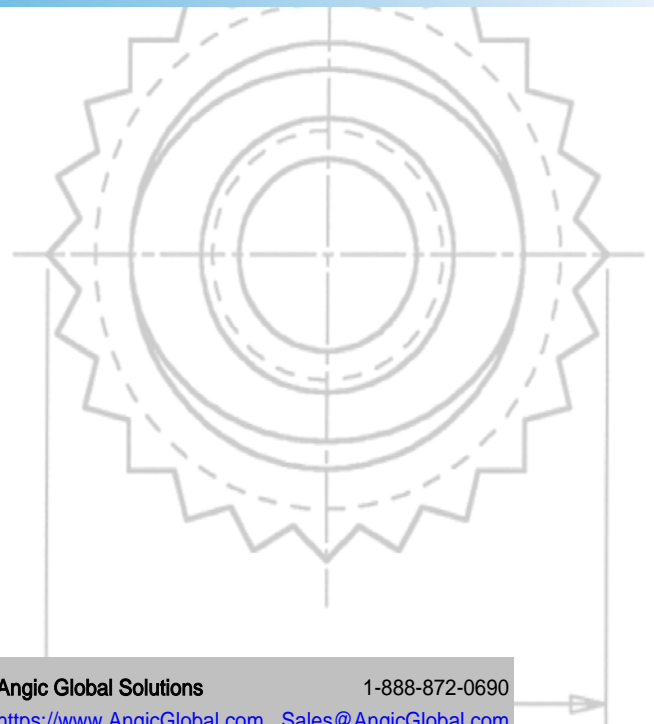

Get quote »

Angic Global Solutions

1-888-872-0690

<https://www.AngicGlobal.com> [Sales@AngicGlobal.com](mailto:Sales@AngicGlobal.com)

# MINIATURE SELF-CLINCHING FASTENERS

**PEM® brand miniature fasteners fit into a minimal space and provide strong, reusable threads.**

PEM miniature fasteners provide visual indication when proper installation has been accomplished.

A strong, knurled collar, which is embedded in the sheet, guarantees against rotation of the fastener in the sheet. The torque-out resistance of the knurl greatly exceeds the torque that can be exerted by the self-locking feature.

When this collar is embedded in the sheet, the undercut cavity beneath the collar is filled with displaced sheet material thereby developing pushout resistance.

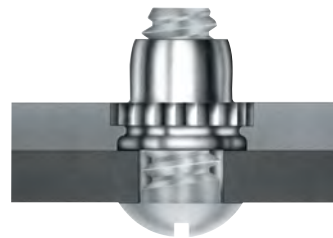

FE™/FEO™/UL™ prevailing torque locknuts provide ideal solutions to prevent mating hardware from loosening in service due to vibration or other application-related factors. A design feature of the lock nut produces friction between threads of mated components thereby increasing the force needed to tighten as well as loosen the nut. Prevailing torque locknuts provide essentially the same torque value regardless of the amount of axial load applied. Their use can save time and money compared with alternative chemical locking methods or patches.

A dry-film lubricant applied to locking FE™/FEO™/UL™ nuts provides the smooth, non-galling prevailing torque performance necessary for reliable locking and for reusability.<sup>(1)</sup> Screws for use with PEM self-clinching locking fasteners should be Class 3A/4h fit or no smaller than Class 2A/6g.

**FE™/FEO™/UL™** elliptically squeezed nuts are **self-locking**. FE/FEO nut thread locking torque performance is equivalent to applicable NASM25027 specifications. UL self-locking nuts meet locking torque requirements specified herein. Some sizes of FE/FEO/UL nuts can be ordered to NASM45938/7 specifications <sup>(2)</sup>. For more information on NASM25027 as applied to PEM self-clinching, self-locking nuts, check our web site for tech sheet PEM® - Ref/NASM25027.



**FEX™/FEOX™/U™** non-locking nuts have class 2B/6H strong reusable threads. These fasteners can be installed into thinner sheets and closer to the edge of a sheet than standard self-clinching nuts. Some sizes of FEX/FEOX/U nuts can be ordered to NASM45938/7 specifications <sup>(2)</sup>.



(1) Consult Bulletin LN for complete line of self-clinching, locking fasteners.

(2) To meet national aerospace standards and to obtain testing documentation, product must be ordered using appropriate NASM45938/7 part number. Check our web site for a complete Military Specification and National Aerospace Standards Reference Guide (Bulletin NASM).

## PART NUMBER DESIGNATION

<b>U</b>	-	<b>080</b>	-	<b>0</b>	
<b>UL</b>	-	<b>080</b>	-	<b>0</b>	<b>CW</b>
<b>FE</b>	-	<b>440</b>	-		<b>MD</b>
<b>FEX</b>	-	<b>440</b>	-		
<b>FEO</b>	-	<b>440</b>	-		<b>MD</b>
<b>FEOX</b>	-	<b>440</b>	-		
↓		↓		↓	↓
Type		Thread Code		Shank Code	Finish Code



# MINIATURE SELF-CLINCHING FASTENERS

## SPECIFICATIONS

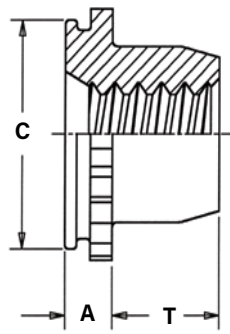

Clinching profile may vary.

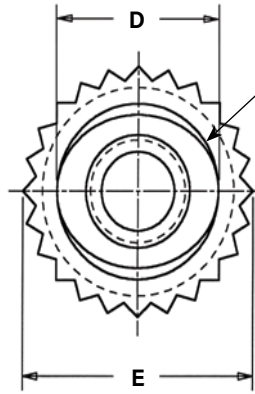

U™/FEX™/FEOX™ NUTS ARE ROUND  
TOPS OF UL™/FE™/FEO™ NUTS HAVE ELLIPTICALLY SQUEEZED LOCKING FEATURE

All dimensions are in inches.

Type	Thread Size	Type		Thread Code	Shank Code (2)	A (Shank) Max.	Sheet Thickness (3)	Hole Size In Sheet +.003 -0.000	C +.000 -0.005	D Max.	E ±.005	T +.015 -0.000	Min. Dist. Hole To Edge	Max. Hole In Attached Parts	
		Non-locking(1)	Self-locking												
UNIFIED	.060-80 (#0-80)	U	UL	080	0	.020	.019-.022	.110	.1095	.076	.125	.050	.09	.080	
	.073-64 (#1-64)	U	UL	164	0	.020	.019-.022	.110	.1095	.090	.125	.050	.09	.093	
	.086-56 (#2-56)	U	UL	256		0	.020	.019-.022	.144	.1435	.106	.160	.065	.11	.106
						1	.031	.030-.036							
	.112-40 (#4-40)	FEOX	FEO	440			.040	.039-.045	.172	.171	.145	.192	.065	.14	.132
							.060	.059-.070							
	.138-32 (#6-32)	FEOX	FEO	632			.040	.039-.045	.213	.212	.180	.244	.075	.17	.158
							.060	.059-.070							
	.164-32 (#8-32)	FEOX	FEO	832			.040	.039-.045	.290	.289	.215	.322	.090	.20	.184
							.060	.059-.070							
	.190-32 (#10-32)	FEOX	FEO	032			.040	.039-.045	.290	.289	.245	.322	.110	.20	.210
							.060	.059-.070							
	1/4-20	FEX	FE	0420			.060	.059-.070	.344	.343	.318	.384	.120	.28	.270
	1/4-28			0428											

All dimensions are in millimeters.

Type	Thread Size x Pitch	Type		Thread Code	Shank Code (2)	A (Shank) Max.	Sheet Thickness (3)	Hole Size In Sheet +0.08	C -0.13	D Max.	E ±0.13	T +0.4	Min. Dist. Hole To Edge	Max. Hole In Attached Parts	
		Non-locking(4)	Self-locking												
METRIC	M2 x 0.4	U	UL	M2	1	0.79	0.76-0.91	3.61	3.6	2.5	4.07	1.65	2.8	2.5	
	M3 x 0.5	FEOX	FEO	M3			1.02	0.99-1.14	4.39	4.37	3.96	4.88	1.9	3.6	3.5
							1.53	1.5-1.78							
	M4 x 0.7	FEOX	FEO	M4			1.02	0.99-1.14	7.39	7.37	5.23	8.17	2.55	5.2	4.5
							1.53	1.5-1.78							
	M5 x 0.8	FEOX	FEO	M5			1.02	0.99-1.14	7.39	7.37	6.48	8.17	3.05	5.2	5.5
							1.53	1.5-1.78							
	M6 x 1	FEX	FE	M6			1.53	1.5-1.78	8.74	8.72	7.72	9.74	3.3	7.1	6.5

- (1) 2B Go Gauge may stop at barrel end but class 3A screw will pass thru with finger torque.
- (2) Shank code applicable only to U and UL fasteners.
- (3) In applications between the sheet thicknesses for your thread size, see last paragraph of installation data on page 4. Knurled collar may fracture if fastener is used in sheets thicker than the specified range and the screw is tightened beyond maximum tightening torque.
- (4) 6H Go Gauge may stop at barrel end but class 4h screw will pass thru with finger torque.



Get quote >>

Angic Global Solutions

1-888-872-0690 [www.angic.com](http://www.angic.com) 47

<https://www.AngicGlobal.com> Sales@AngicGlobal.com

# MINIATURE SELF-CLINCHING FASTENERS

## MATERIAL AND FINISH SPECIFICATIONS

Type	Threads		Fastener Material	Standard Finishes			For Use In Sheet Hardness <sup>(1)</sup>	Locking Temperature Limit	Self-locking	Covered by M45938/7 <sup>(2)</sup>
	Internal, ASME B1.1, 2B / ASME B1.13M, 6H	Internal, UNJ Class 3B per ASME B1.15 / MJ Class 4H6H per ASME B1.21M (M6 thread 4H5H)		Passivated and/or Tested Per ASTM A380	Passivated Plus Clear Dry-film Lubricant	Black Dry-film Lubricant				
U	▪		▪	▪			▪		▪	
UL		▪	▪		▪		▪	400° F / 204° C	▪	
FE		▪	▪	▪		▪	▪	400° F / 204° C	▪	
FEX	▪		▪	▪			▪		▪	
FEO		▪	▪	▪		▪	▪	400° F / 204° C	▪	
FE0X	▪		▪	▪			▪		▪	
Part number codes for finishes				None	CW <sup>(3)</sup>	MD <sup>(4)</sup>				

(1) HRB - Hardness Rockwell "B" Scale. HB - Hardness Brinell.

(2) To meet national aerospace standards and to obtain testing documentation, product must be ordered using appropriate NASM45938 part number. Check our web site for a complete Military Specification and National Aerospace Standards Reference Guide (Bulletin NASM).

(3) See PEM Technical Support section of our web site for related plating standards and specifications.

(4) MD finish on stainless steel provides a minimum of 100 hours of salt spray resistance.

## INSTALLATION

1. Prepare properly sized mounting hole in sheet. Do not perform any secondary operations such as deburring.
2. Insert fastener into the anvil hole and place the mounting hole (preferably the punch side) over the shank of the fastener as shown in the drawing.
3. With installation punch and anvil surfaces parallel, apply squeezing force to the knurled collar until knurled collar is flush with top of the sheet for sheets .060"/1.5mm thick and up, or until shank is flush with the bottom of the sheet for sheets .040"/1mm to .060"/1.5mm thick for FE/FEO nuts.

PEM miniature fasteners must be installed by a force applied through parallel surfaces. Since force must not be applied to the barrel, a cavity must be used in either the punch or anvil so that the installation force is applied to the knurled collar. "D" dimensions for the punch or anvil cavity are given in the tables on page 49.

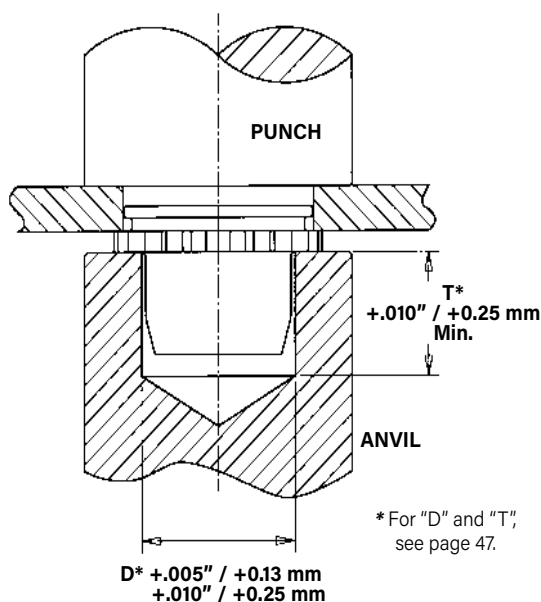

### INSTALLATION NOTES

- For best results we recommend using a PEMSERTER® or Haeger® machine for installation of PEM® self-clinching fasteners. Please check our website for more information.
- Visit the Animation Library on our website to view the installation process [for this product](#).

## PEMSERTER® Installation Tooling

Type	Thread	Anvil Part Number	Punch Part Number
U/UL	080	8008451	975200048
U/UL	164	970200300300	
U/UL	256/M2	975200020	
FE/FEO/FEX/FE0X	440/M3	975200021	
FE/FEO/FEX/FE0X	632	975200022	
FE/FEO/FEX/FE0X	832/M4	975200023	
FE/FEO/FEX/FE0X	032/M5	975200024	
FE/FEO/FEX/FE0X	0420	975200025	
FE/FEO/FEX/FE0X	M6	8013143	

## INSTALLATION RECOMMENDATION

In applications for sheet thicknesses between the two ranges (see "Sheet Thickness" on page 49) use the fastener with the larger "A" dimension. For example, if you want a #4-40 thread and your sheet thickness is between .045"/1.14 mm and .059"/1.49 mm, you should use FE or FEX nuts. This is not recommended installation practice, but in this case if it is necessary, you should install the fastener so that the bottom of the shank is flush with the underside of the sheet (instead of having the top of the knurled collar flush with the top of the sheet). When this method is used, care must be taken to protect the fastener against crushing which would damage the threads. This method will also result in reduced pushout and torque-out values.

# MINIATURE SELF-CLINCHING FASTENERS

## PERFORMANCE DATA FOR U™/UL™ FASTENERS<sup>(1)</sup>

UNIFIED	Type	Thread Code	Shank Code	Test Sheet Material					
				5052-H34 Aluminum			Cold-rolled Steel		
				Installation (lbs.)	Pushout (lbs.)	Torque-out (in. lbs.)	Installation (lbs.)	Pushout (lbs.)	Torque-out (in. lbs.)
U/UL	080	0		750	20	2	1000	30	2
	164	0		750	20	3	1000	30	3
	256	0		1000	20	4	1300	30	4
1									

METRIC	Type	Thread Code	Shank Code	Test Sheet Material					
				5052-H34 Aluminum			Cold-rolled Steel		
				Installation (kN)	Pushout (N)	Torque-out (N-m)	Installation (kN)	Pushout (N)	Torque-out (N-m)
U/UL	M2	1		4	89	0.45	5.8	133	0.45

## PERFORMANCE DATA FOR FE™/FEO™/FEX™/FEOX™ FASTENERS<sup>(1)(2)</sup>

UNIFIED	Type	Thread Code	Test Sheet Material					
			5052-H34 Aluminum			Cold-rolled Steel		
			Installation (lbs.)	Pushout (lbs.)	Torque-out (in. lbs.)	Installation (lbs.)	Pushout (lbs.)	Torque-out (in. lbs.)
FEO/FEOX	440	440	900	88	12	1500	140	12
FE/FEX				135			210	
FEO/FEOX	632	632	1200	105	20	2100	185	20
FE/FEX				1300			175	
FEO/FEOX	832	832	1500	155	48	2500	260	48
FE/FEX				255			360	
FEO/FEOX	032	032	1500	155	48	2500	260	48
FE/FEX				255			360	
FE/FEX	0420	0428	2100	320	110	3500	420	110
	0428							

METRIC	Type	Thread Code	Test Sheet Material					
			5052-H34 Aluminum			Cold-rolled Steel		
			Installation (kN)	Pushout (N)	Torque-out (N-m)	Installation (kN)	Pushout (N)	Torque-out (N-m)
FEO/FEOX	M3	M3	4	391	1.35	6.7	622	1.35
FE/FEX				600			934	
FEO/FEOX	M4	M4	6.7	689	5.42	11.1	1156	5.42
FE/FEX				1134			1601	
FEO/FEOX	M5	M5	6.7	689	5.42	11.1	1156	5.42
FE/FEX				1134			1601	
FE/FEX	M6	M6	9.4	1423	12.43	15.6	1868	12.43

(1) Published installation forces are for general reference. Actual set-up and confirmation of complete installation should be made by observing proper seating of fastener as described in the installation steps. Other performance values reported are averages when all proper installation parameters and procedures are followed. Variations in mounting hole size, sheet material, and installation procedure may affect performance. Performance testing this product in your application is recommended. We will be happy to provide technical assistance and/or samples for this purpose.

(2) For FE and FEO fasteners, thread locking performance is equivalent to applicable NASM25027 specifications. Consult technical sheet PEM-REF/NASM25027 on our web site for details.



Get quote >>

Angic Global Solutions

1-888-872-0690 [et.com](http://www.angic.com) 49

<https://www.AngicGlobal.com> Sales@AngicGlobal.com

# MINIATURE SELF-CLINCHING FASTENERS

## AXIAL STRENGTH AND TIGHTENING TORQUE COMPARISON

UNIFIED	Thread Code	Increasing Axial Strength →					
		U-0/UL-0/FE0X/FE0 Nuts			U-1/UL-1/FE1X/FE Nuts		
		Locknut Min. Axial Strength (lbs.) <sup>(1)</sup>	Mating Screw		Locknut Min. Axial Strength (lbs.) <sup>(1)</sup>	Mating Screw	
			Strength Level (ksi) <sup>(2)</sup>	Tightening Torque (in. lbs.) <sup>(3)</sup>		Strength Level (ksi) <sup>(2)</sup>	Tightening Torque (in. lbs.) <sup>(3)</sup>
080	125	69	1.0	—	—	—	
164	125	49	1.2	—	—	—	
256	169	46	1.9	316	85	3.5	
440	465	77	6.8	705	117	10.3	
632	546	60	9.8	847	93	15.2	
832	779	56	16.6	1,213	87	25.9	
032	779	39	19.2	1,213	61	30.0	
0420	—	—	—	1,412	44	45.9	

METRIC	Thread Code	Increasing Axial Strength →					
		U-0/UL-0/FE0X/FE0 Nuts			U-1/UL-1/FE1X/FE Nuts		
		Locknut Min. Axial Strength (kN) <sup>(1)</sup>	Mating Screw		Locknut Min. Axial Strength (kN) <sup>(1)</sup>	Mating Screw	
			Strength Level (MPa) <sup>(2)</sup>	Tightening Torque (N-m) <sup>(3)</sup>		Strength Level (MPa) <sup>(2)</sup>	Tightening Torque (N-m) <sup>(3)</sup>
M2	—	—	—	1.39	432	0.36	
M3	2.08	267	0.81	3.16	405	1.23	
M4	3.48	255	1.81	5.42	398	2.82	
M5	3.48	158	2.26	5.42	246	3.52	
M6	—	—	—	6.28	201	4.9	

(1) Axial strength for nuts is limited by knurled ring strength.

(2) Screw strength level shown is the minimum needed to develop full nut strength, higher strength screws may be used.

(3) Tightening torque shown will induce preload of 65% of locknut minimum axial strength with K or nut factor is equal to 0.20. In some applications tightening torque may need to be adjusted based on the actual K value. If screw strength is less than the value shown, tightening torque should be proportionately reduced by multiplying the torque shown by the actual screw strength over the screw strength shown. If higher strength screws are used, torque is not adjusted upward because assemble strength is still limited by locknut strength.

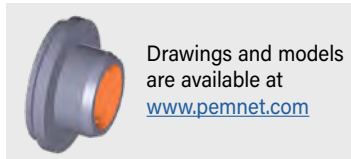



PEM® brand self-clinching studs and pins install permanently in aluminum, steel or stainless steel sheets.



**FH™**

**SELF-CLINCHING  
STUDS AND PINS**

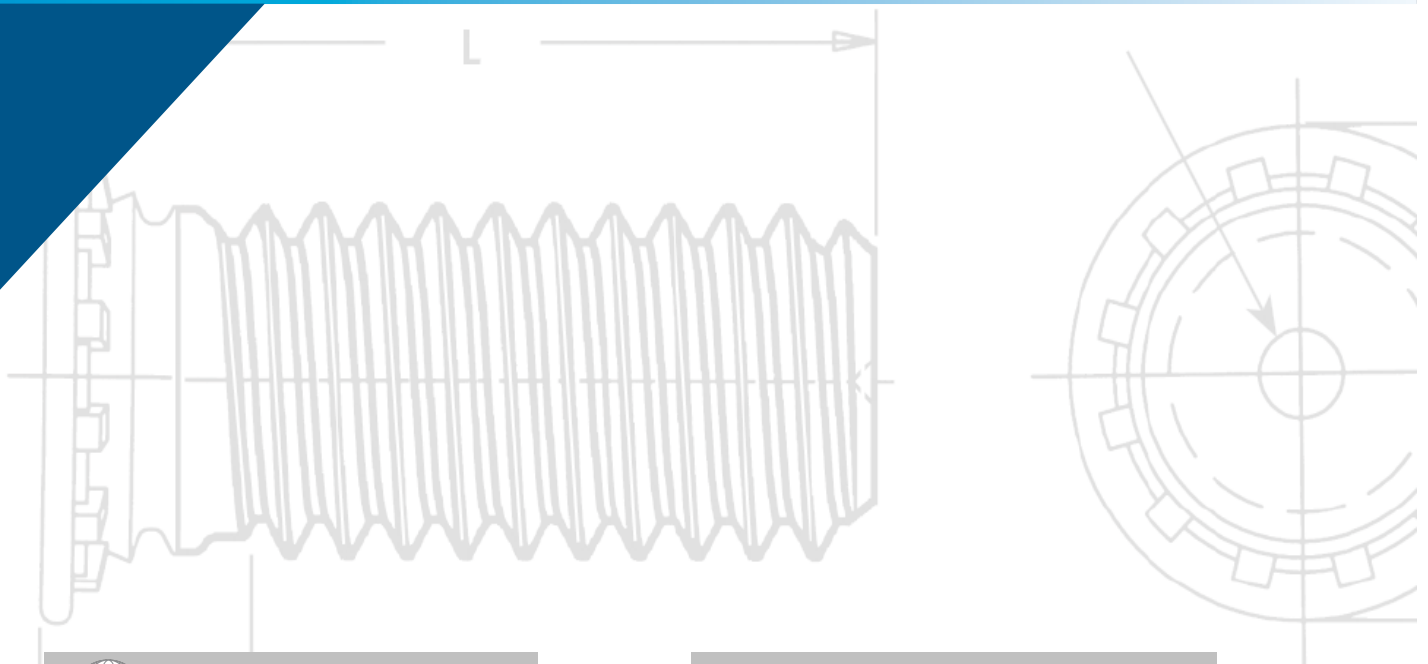

Get quote »

Angic Global Solutions















1-888-872-0690

<https://www.AngicGlobal.com> [Sales@AngicGlobal.com](mailto:Sales@AngicGlobal.com)

# SELF-CLINCHING STUDS AND PINS

**PEM® self-clinching studs are easily installed by placing them in properly sized holes in sheets and squeezing into place with any standard press:**

- Install permanently in aluminum, steel or stainless steel in sheets as thin as .020" / 0.51 mm.
- High torque-out and pushout resistances.

<p>Dog Point and Anti Cross-Thread Options - <b>PAGE 54</b></p>		<p><b>HFE™/THFE™ (heavy-duty) studs</b> Provides maximum pull through in sheets as thin as .031" / 0.8 mm - <b>PAGE 60</b></p>	
<p><b>FH™/FHS™/FHA™ (flush-head) studs</b> are available in aluminum, steel, or stainless steel - <b>PAGE 55</b></p>		<p><b>HFG8™/HF109™ (heavy-duty high tensile strength) studs</b> are manufactured for the most demanding applications from medium carbon alloy steel, then heat-treated to high strength and hardness qualities - <b>PAGE 61</b></p>	
<p><b>FH4™/FHP™ (flush-head) studs</b> are designed to provide strong threads in stainless steel sheets as thin as .040"/1 mm. FHP studs have high corrosion resistance - <b>PAGE 56</b></p>		<p><b>HFLH™ studs</b> are for installation into thin, harder, high-strength materials - <b>PAGE 62</b></p>	
<p><b>FHL™/FHLS™ (flush, low-displacement head) studs</b> have a smaller head diameter and install closer to the edge of a sheet than PEM FH/FHS studs - <b>PAGE 57</b></p>		<p><b>SGPC™ swaging collar studs</b> can install into most panel material and accommodate multiple panels as long as the total thickness does not exceed the maximum sheet thickness - <b>PAGE 63</b></p>	
<p><b>TFH™/TFHS™ (non-flush) studs</b> are for sheets as thin as .020" / 0.51 mm. The stud head will project above the sheet surface approximately .025"/0.64mm - <b>PAGE 58</b></p>		<p><b>FHX™ flush-head studs with X-Press™ thread profile</b> are typically used with push-on or other plastic fasteners - <b>PAGE 64</b></p>	
<p><b>HFH™/HFHS™ (heavy-duty) studs</b> have a large head which projects above the sheet material to distribute the axial tightening force over a large area thereby improving pull through resistance - <b>PAGE 59</b></p>		<p><b>FH™/FHS™/FHA™ (flush-head) Pins</b> are available on special order - <b>PAGE 65</b></p>	
<p><b>HFHB™ (heavy-duty BUSBAR®) studs</b> are ideal for applications which demand superior electrical/mechanical attachment points - <b>PAGE 59</b></p>		<p><b>TPS™/TP4™/TPXS™ (flush-head) pilot pins</b> satisfy a wide range of positioning, pivot, and alignment applications - <b>PAGE 66</b></p>	
<p><b>Material and finish specifications - PAGE 67</b></p>			
<p><b>Installation - PAGES 70 - 75</b></p>			
<p><b>Performance data - PAGES 76 - 82</b></p>			



Flush-head studs  
Types FH/FHA/FHS/FHP/FH4



Flush, low-displacement head studs  
Types FHL/FHLS



Thin sheet studs  
Types TFH/TFHS



Heavy-duty studs  
Types HFH/HFHS/HFHB



Heavy-duty studs for thin sheets  
Types HFE/THFE

# SELF-CLINCHING STUDS AND PINS

## STUD SELECTOR GUIDE

PEM Stud Type	Application Requires:											
	Flush-head	Heavy duty	Sheet thickness as thin as .020" / 0.51 mm	Superior electrical conductivity	Installation into stainless steel sheets	Compatibility with aluminum anodizing	Superior corrosion resistance	Closest centerline-to-edge distance	Unthreaded stud/pin	Largest hole in attached Panel	Non-magnetic	Max. panel hardness (2)
FH	▪											HRB 80 HB 150
FHA	▪					▪	▪				▪	HRB 50 HB 82
FHS	▪						▪				▪	HRB 70 HB 125
FH4	▪				▪							HRB 92 HB 202
FHP	▪				▪		▪				▪	HRB 92 HB 202
FHL	▪							▪				HRB 80 HB 150
FHLS	▪						▪	▪			▪	HRB 70 HB 125
TFH			▪									HRB 80 HB 150
TFHS			▪				▪				▪	HRB 70 HB 125
HFH		▪ <sup>(1)</sup>								▪		HRB 85 HB 165
HFHB		▪		▪			▪			▪	▪	HRB 55 HB 83
HFHS		▪					▪			▪	▪	HRB 70 HB 125
HFE		▪								▪		HRB 85 HB 165
THFE		▪								▪		HRB 85 HB 165
HFG8/HF109		▪ <sup>(3)</sup>								▪		HRB 89 HB 180
HFLH		▪								▪		HRB 96 HB 216
SGPC					▪			▪			▪	Any sheet hardness
FHX	▪											HRB 80 HB 150
FH Unthreaded	▪								▪			HRB 80 HB 150
FHA Unthreaded	▪					▪	▪		▪		▪	HRB 50 HB 82
FHS Unthreaded	▪						▪		▪		▪	HRB 70 HB 125
TPS	▪						▪		▪		▪	HRB 70 HB 125
TP4	▪				▪				▪			HRB 92 HB 202
TPXS	▪						▪		▪		▪	HRB 70 HB 125

(1) Meets grade 5 / property class 9.8 tensile requirements.

(2) HRB - Hardness Rockwell "B" Scale. HB - Hardness Brinell.

(3) Grade 8 / Property Class 10.9 thread strength.

Standard product features shown above. Studs can also be custom designed to meet your exact application requirements.



Heavy-duty, high tensile strength studs  
Types HFG8/HF109



Studs for hard panels  
Type HFLH



Swaging collar studs  
Type SGPC



Flush-head Studs with  
X-Press™ Thread Profile  
Type FHX



Flush-head pins  
Types TPS/TP4



Get quote »

Angic Global Solutions

1-888-872-0690 [www.AngicGlobal.com](http://www.AngicGlobal.com) 53

[www.AngicGlobal.com](http://www.AngicGlobal.com) Sales@AngicGlobal.com

# SELF-CLINCHING STUDS AND PINS

## OPTIONAL DOG POINT FEATURE

PEM® dog point lead-in option for studs allows quick location of the mating fastener during assembly and protects the first thread of the stud during nut engagement. This feature is available on Types FH, FHL, HFH, HFE, HF109, HFG8, TFH and THFE studs.

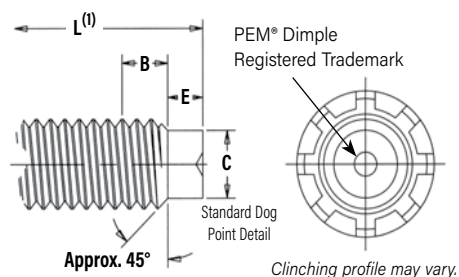

All dimensions are in inches.

Unified Thread Size	C ±.005 (2)	E ±.010	B Nom. Transitional Length to Full Thread
.138-32 (#6-32)	.086	.050	.098
.164-32 (#8-32)	.111	.055	.099
.190-24 (#10-24)	.124	.065	.127
.190-32 (#10-32)	.138	.065	.098
.250-20 (1/4-20)	.173	.085	.149
.250-28 (1/4-28)	.192	.085	.110
.313-18 (5/16-18)	.228	.105	.164
.313-24 (5/16-24)	.246	.105	.127
.375-16 (3/8-16)	.282	.125	.182
.375-24 (3/8-24)	.309	.125	.126

All dimensions are in millimeters.

Metric Thread Size	C ±0.13 (2)	E ±0.25	B nom. Transitional Length to Full Thread
M3.5 x 0.6	2.4	1.27	1.88
M4 x 0.7	2.79	1.4	2.26
M5 x 0.8	3.66	1.78	2.48
M6 x 1	4.37	2.03	3.05
M8 x 1.25	6.05	2.67	3.73
M10 x 1.5	7.72	3.43	4.37

### OPTIONAL PART NUMBER DESIGNATION

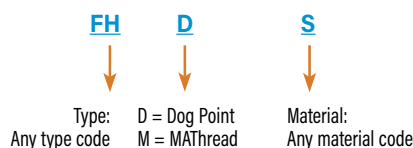

(1) For "L" refer to type stud lengths.

(2) Maximum dog point diameter is .003" / 0.08 mm less than minimum minor diameter of 2B or 6H nut threads.

## OPTIONAL MATHread® ANTI CROSS-THREAD FEATURE

PennEngineering is a licensee of MATHread® Anti Cross-Threading Technology. This unique design allows the threads to self-align and drive easily with reduced effort. This helps speed assembly, reduce or eliminate failures, repairs, scrap, downtime, and warranty service associated with thread damage. This option is available on most types of PEM® studs.



Anti Cross-Thread Feature

MATHread is a registered trademark of MATHread inc.

## OPTIONAL POINTED STUD FEATURE

A pointed lead-in option for studs allows quick location of mating fastener during assembly to speed assembly and significantly reduces the likelihood of cross threading. Clip grooves for snap rings can also be added. This feature can be added to most types of PEM® studs.

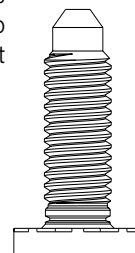

## OPTIONAL THREAD MASK

Thread mask is available for applications where hardware is installed prior to painting. During assembly, the threads of the mating hardware will remove paint, electro deposited automotive under coatings, and weld spatter upon application of torque. PEM® studs can be specially ordered with thread mask applied. [Click here](#) for more information.



"BC" suffix will be added to part number to designate thread mask to fastener.

Thread mask color may vary.

## AVAILABLE PEM® VARIMOUNT® FASTENING SYSTEM

The PEM® VariMount® fastening system (see PEM® Bulletin VM) utilizes a self-clinching stud paired with a round steel or stainless steel base plate to offer a clean and ready-made assembly for mounting into any rigid material or panel, including composites, plastics, and metals. Multiple radial holes in the base plate and a generous footprint provide effective mounting of the assembly. Mounting can be performed either on the front or through the back of a panel.



# SELF-CLINCHING STUDS AND PINS

## FH™/FHS™/FHA™ FLUSH-HEAD STUDS

- Flush-head for sheet thickness of .040" / 1 mm and greater.
- FH studs are recommended for use in steel or aluminum sheets HRB (Rockwell "B" scale) 80 / HB (Hardness Brinell) 150 or less.
- FHS studs are recommended for use in steel or aluminum sheets HRB (Rockwell "B" scale) 70 / HB (Hardness Brinell) 125 or less.
- FHA studs are recommended for use in aluminum sheets HRB (Rockwell "B" scale) 50 / HB (Hardness Brinell) 82 or less.

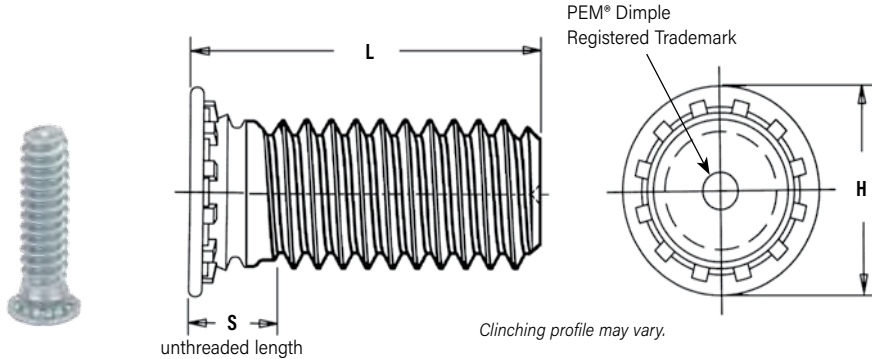

### PART NUMBER DESIGNATION

FH	-	632	-	6	ZI
FH	S	-	632	-	6
FH	A	-	632	-	6
↓	↓	↓	↓	↓	↓
Type	Material Code	Thread Code	Length Code	Finish Code	

All dimensions are in inches.

UNIFIED	Thread Size	Type			Thread Code	Length Code "L" ±.015 (Length Code in 16ths of an inch)										Min. Sheet Thickness (1)	Hole Size in Sheet +.003 -0.000	H ±.015	S Max. (2)	Max. Hole in Attached Parts	Min. Dist. Hole ⌀ to Edge
		Fastener Material				.250	.312	.375	.500	.625	.750	.875	1.00	1.25	1.50						
		Steel	Stainless Steel	Aluminum																	
	.086-56 (#2-56)	FH	FHS	-	256	4	5	6	8	10	12	-	-	-	-	.040	.085	.144	.075	.105	.187
	.112-40 (#4-40)	FH	FHS	FHA	440	4	5	6	8	10	12	14	16	20	-	.040	.111	.176	.085	.135	.219
	.138-32 (#6-32)	FH	FHS	FHA	632	4	5	6	8	10	12	14	16	20	24	.040	.137	.206	.090	.160	.250
	.164-32 (#8-32)	FH	FHS	FHA	832	4	5	6	8	10	12	14	16	20	24	.040	.163	.237	.090	.185	.281
	.190-24 (#10-24)	FH	FHS	FHA	024	-	5	6	8	10	12	14	16	20	24	.040	.189	.256	.100	.210	.281
	.190-32 (#10-32)	FH	FHS	FHA	032	-	5	6	8	10	12	14	16	20	24	.040	.189	.256	.100	.210	.281
	.250-20 (1/4-20)	FH	FHS	FHA	0420	-	-	6	8	10	12	14	16	20	24	.062	.249	.337	.135	.270	.312
	.313-18 (5/16-18)	FH	FHS	-	0518	-	-	-	8	10	12	14	16	20	24	.093	.311	.376	.160	.333	.375

All dimensions are in millimeters.

METRIC	Thread Size x Pitch	Type			Thread Code	Length Code "L" ±0.4 (Length Code in millimeters)										Min. Sheet Thickness (1)	Hole Size in Sheet +0.08	H ± 0.4	S Max. (2)	Max. Hole in Attached Parts	Dist. Hole ⌀ to Edge
		Fastener Material				6	8	10	12	15	18	20	25	30	35						
		Steel	Stainless Steel	Aluminum																	
	M2.5 x 0.45	FH	FHS	FHA	M2.5	6	8	10	12	15	18	-	-	-	-	1	2.5	4.1	1.95	3.1	5.4
	M3 x 0.5	FH	FHS	FHA	M3	6	8	10	12	15	18	20	25	-	-	1	3	4.6	2.1	3.6	5.6
	M3.5 x 0.6	FH	FHS	FHA	M3.5	6	8	10	12	15	18	20	25	30	-	1	3.5	5.3	2.25	4.1	6.4
	M4 x 0.7	FH	FHS	FHA	M4	6	8	10	12	15	18	20	25	30	35	1	4	5.9	2.4	4.6	7.2
	M5 x 0.8	FH	FHS	FHA	M5	-	8	10	12	15	18	20	25	30	35	1	5	6.5	2.7	5.6	7.2
	M6 x 1	FH	FHS	FHA	M6	-	-	10	12	15	18	20	25	30	35	1.6	6	8.2	3	6.6	7.9
	M8 x 1.25	FH	FHS	-	M8	-	-	-	12	15	18	20	25	30	35	2.4	8	9.6	3.7	8.6	9.6

(1) See page 68 for installation tool requirements.

(2) Threads are gaugeable to within 2 pitches of the "S" Max. dimension. A class 3B/5H maximum material commercial nut shall pass up to the "S" Max. dimension.



Get quote >>

Angic Global Solutions

1-888-872-0690 [www.angic.com](http://www.angic.com) 55

<https://www.AngicGlobal.com> Sales@AngicGlobal.com

# SELF-CLINCHING STUDS AND PINS

## FH4™/FHP™ FLUSH-HEAD STUDS FOR STAINLESS STEEL SHEETS

- FHP studs offer optimum corrosion resistance and are ideal for medical, foodservice, and marine applications.
- Recommended for use in stainless steel sheets HRB (Rockwell "B" Scale) 92 / HB (Hardness Brinell) 195 or less.

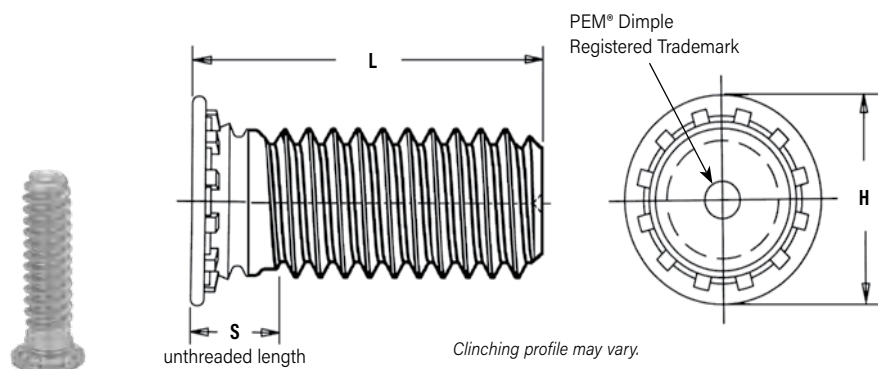

### PART NUMBER DESIGNATION

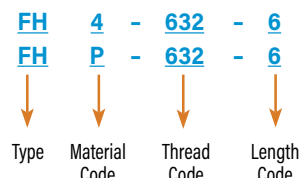

All dimensions are in inches.

UNIFIED	Thread Size	Type		Thread Code	Length Code "L" ±.015 (Length code in 16ths of an inch)										Sheet Thickness (2)	Hole Size in Sheet +.003 - .000	H ±.015	S Max. (3)	Max. Hole in Attached Parts	Min. Dist. Hole to Edge
		Fastener Material																		
		Stainless Steel (1)																		
	.112-40 (#4-40)	FH4	FHP	440	4	5	6	8	10	12	14	16	—	—	.040-.095	.111	.176	.085	.131	.219
	.138-32 (#6-32)	FH4	FHP	632	4	5	6	8	10	12	14	16	20	24	.040-.095	.137	.206	.090	.157	.250
	.164-32 (#8-32)	FH4	FHP	832	4	5	6	8	10	12	14	16	20	24	.040-.095	.163	.237	.090	.183	.281
	.190-32 (#10-32)	FH4	FHP	032	—	5	6	8	10	12	14	16	20	24	.040-.095	.189	.256	.100	.209	.281
	.250-20 (1/4-20)	FH4	—	0420	—	—	6	8	10	12	14	16	20	24	.062-.117	.249	.337	.135	.269	.312

All dimensions are in millimeters.

METRIC	Thread Size x Pitch	Type		Thread Code	Length Code "L" ±0.4 (Length Code in millimeters)										Sheet Thickness	Hole Size in Sheet +0.08	H ±0.4 (3)	S Max. Parts	Max. Hole in Attached	Min. Dist. Hole to Edge
		Fastener Material																		
		Stainless Steel (1)																		
	M3 x 0.5	FH4	FHP	M3	6	8	10	12	15	18	20	25	—	—	1 - 2.4	3	4.6	2.1	3.3	5.6
	M4 x 0.7	FH4	FHP	M4	6	8	10	12	15	18	20	25	30	35	1 - 2.4	4	5.9	2.4	4.7	7.2
	M5 x 0.8	FH4	FHP	M5	—	8	10	12	15	18	20	25	30	35	1 - 2.4	5	6.5	2.7	5.3	7.2
	M6 x 1	FH4	—	M6	—	—	10	12	15	18	20	25	30	35	1.6 - 3	6	8.2	3	6.8	7.9

(1) See material and finish specifications chart on page 67 for details.

(2) See page 69 for installation tool requirements. Performance may be reduced for studs installed into thicker sheets.

(3) Threads are gaugeable to within 2 pitches of the "S" Max. dimension. A class 3B/5H maximum material commercial nut shall pass up to the "S" Max. dimension.

### A NOTE ABOUT 400 SERIES FASTENERS FOR STAINLESS STEEL PANELS

In order for self-clinching fasteners to work properly, the fastener must be harder than the sheet into which it is being installed. In the case of stainless steel panels, fasteners made from 300 Series Stainless Steel do not meet this hardness criteria. For this reason, we offer FH4™ and TP4™ 400 series fasteners. However, while these 400 Series fasteners install and perform well in 300 Series stainless sheets they should not be used if the end product:

- Will be exposed to any appreciable corrosive presence.
- Requires non-magnetic fasteners.
- Will be exposed to any temperatures above 300°F (149°C)

If any of these are issues, please contact [techsupport@pemnet.com](mailto:techsupport@pemnet.com) for other options such as the FHP™ stud, made from precipitation hardened grade stainless steel which is not subject to these issues.

# SELF-CLINCHING STUDS AND PINS

## FHL™/FHLS™ FLUSH, LOW-DISPLACEMENT HEAD STUDS

- Installs closer to the edge of a sheet than PEM Type FH/FHS studs without causing that edge to bulge.
- Flush-head for sheet thickness .040" / 1 mm and greater.
- FHL studs are recommended for use in steel or aluminum sheets HRB (Rockwell "B" Scale) 80 / HB (Hardness Brinell) 150 or less.
- FHLS studs are recommended for use in steel or aluminum sheets HRB (Rockwell "B" Scale) 70 / HB (Hardness Brinell) 125 or less.

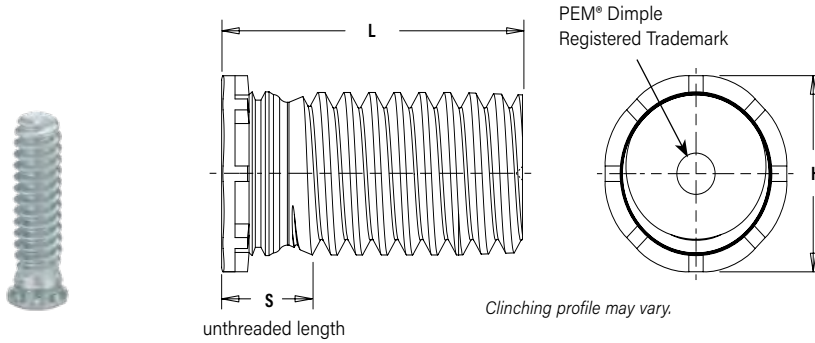

### PART NUMBER DESIGNATION

**FHL** - **632** - **6** **ZI**  
**FHL** **S** - **632** - **6**

↓   ↓   ↓   ↓   ↓  
 Type   Material Code   Thread Code   Length Code   Finish Code

All dimensions are in inches.

UNIFIED	Thread Size	Type		Thread Code	Length Code "L" ±.015 (Length Code in 16ths of an inch)									Min. Sheet Thickness (1)	Hole Size in Sheet +.003 -0.000	H ±.015	S Max. (2)	Max. Hole in Attached Parts	Min. Dist. Hole to Edge	
		Fastener Material			.250	.312	.375	.500	.625	.750	.875	1.00	1.25							1.50
		Steel	Stainless Steel																	
	.086-56 (#2-56)	FHL	FHLS	256	4	5	6	8	10	12	—	—	—	—	.040	.085	.112	.080	.100	.098
	.112-40 (#4-40)	FHL	FHLS	440	4	5	6	8	10	12	14	16	—	—	.040	.111	.138	.085	.126	.124
	.138-32 (#6-32)	FHL	FHLS	632	4	5	6	8	10	12	14	16	20	24	.040	.137	.164	.090	.152	.150
	.164-32 (#8-32)	FHL	FHLS	832	4	5	6	8	10	12	14	16	20	24	.040	.163	.190	.090	.178	.176
	.190-32 (#10-32)	FHL	FHLS	032	—	5	6	8	10	12	14	16	20	24	.040	.189	.225	.100	.204	.210

All dimensions are in millimeters.

METRIC	Thread Size x Pitch	Type		Thread Code	Length Code "L" ±0.4 (Length Code in millimeters)									Min. Sheet Thickness (1)	Hole Size in Sheet +0.08	H ±0.4	S Max. (2)	Max. Hole in Attached Parts	Min. Dist. Hole to Edge	
		Fastener Material			6	8	10	12	15	18	20	25	30							35
		Steel	Stainless Steel																	
	M2.5 x 0.45	FHL	FHLS	M2.5	6	8	10	12	15	18	—	—	—	—	1	2.5	3.15	2.1	2.9	2.8
	M3 x 0.5	FHL	FHLS	M3	6	8	10	12	15	18	20	25	—	—	1	3	3.65	2.1	3.2	3.3
	M3.5 x 0.6	FHL	FHLS	M3.5	6	8	10	12	15	18	20	25	30	—	1	3.5	4.15	2.3	3.9	3.8
	M4 x 0.7	FHL	FHLS	M4	6	8	10	12	15	18	20	25	30	35	1	4	4.65	2.4	4.5	4.3
	M5 x 0.8	FHL	FHLS	M5	—	8	10	12	15	18	20	25	30	35	1	5	5.9	2.7	5.2	5.6

(1) See page 69 for installation tool requirements.

(2) Threads are gaugeable to within 2 pitches of the "S" Max. dimension. A class 3B/5H maximum material commercial nut shall pass up to the "S" Max. dimension.

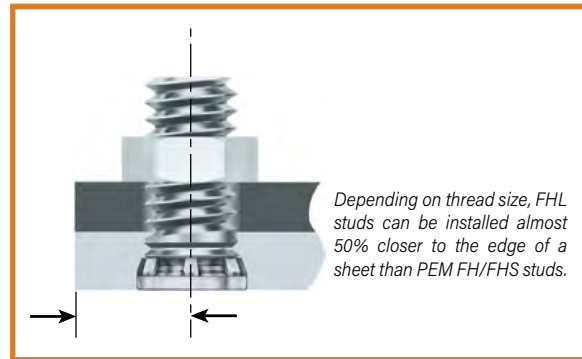

Get quote >>

Angic Global Solutions

1-888-872-0690 [www.angic.com](http://www.angic.com) 57

<https://www.AngicGlobal.com> Sales@AngicGlobal.com

# SELF-CLINCHING STUDS AND PINS

## TFH™/TFHS™ NON-FLUSH STUDS

- Non-flush for sheets as thin as .020" / 0.51 mm.
- TFH studs are recommended for use in steel or aluminum sheets HRB (Rockwell "B" Scale) 80 / HB (Hardness Brinell) 150 or less.
- TFHS studs are recommended for use in steel or aluminum sheets HRB (Rockwell "B" Scale) 70 / HB (Hardness Brinell) 125 or less.

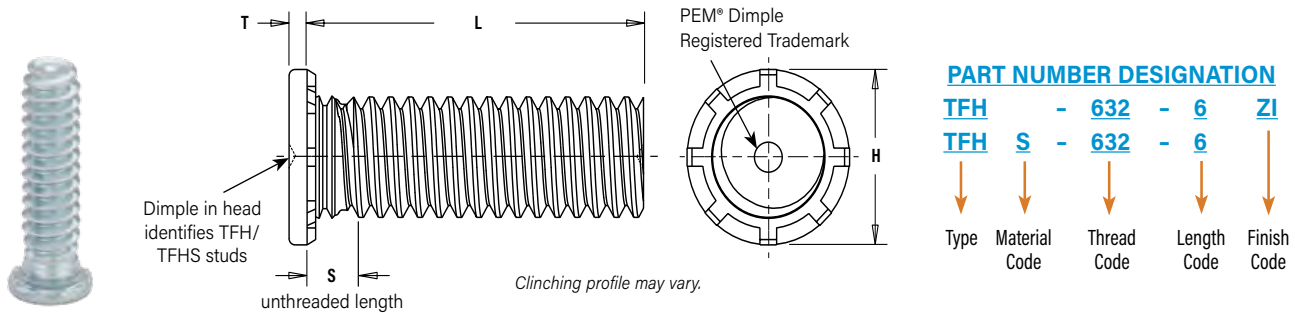

All dimensions are in inches.

UNIFIED	Thread Size	Type		Thread Code	Length Code "L" ±.015 (Length Code in 16ths of an inch)									Min. Sheet Thickness (t)	Hole Size in Sheet +.003 -0.00	H ±.015	S Max. (2)	T Max.	Max. Hole in Attached Parts	Min. Dist. Hole to Edge	
		Fastener Material			.250	.312	.375	.500	.625	.750	.875	1.00	1.25								1.50
		Steel	Stainless Steel																		
.086-56 (#2-56)	TFH	TFHS	256	4	5	6	8	10	12	-	-	-	.020	.085	.141	.070	.025	.105	.187		
.112-40 (#4-40)	TFH	TFHS	440	4	5	6	8	10	12	14	-	-	.020	.111	.176	.070	.025	.131	.219		
.138-32 (#6-32)	TFH	TFHS	632	4	5	6	8	10	12	14	16	20	24	.020	.137	.203	.070	.025	.157	.250	
.164-32 (#8-32)	TFH	TFHS	832	4	5	6	8	10	12	14	16	20	24	.020	.163	.234	.070	.025	.183	.281	
.190-24 (#10-24)	TFH	TFHS	024	-	5	6	8	10	12	14	16	20	24	.020	.189	.250	.090	.025	.209	.281	
.190-32 (#10-32)	TFH	TFHS	032	-	5	6	8	10	12	14	16	20	24	.020	.189	.250	.090	.025	.209	.281	

All dimensions are in millimeters.

METRIC	Thread Size x Pitch	Type		Thread Code	Length Code "L" ±0.4 (Length Code in millimeters)									Min. Sheet Thickness (t)	Hole Size in Sheet +0.08	H ±0.4	S Max. (2)	T Max.	Max. Hole in Attached Parts	Min. Dist. Hole to Edge	
		Fastener Material			6	8	10	12	15	18	20	25	30								35
		Steel	Stainless Steel																		
M3 x 0.5	TFH	TFHS	M3	6	8	10	12	15	18	20	25	-	-	0.51	3	4.5	1.8	0.64	3.3	5.6	
M4 x 0.7	TFH	TFHS	M4	-	8	10	12	15	18	20	25	30	35	0.51	4	5.8	1.8	0.64	4.7	7.2	
M5 x 0.8	TFH	TFHS	M5	-	8	10	12	15	18	20	25	30	35	0.51	5	6.4	2.3	0.64	5.3	7.2	

- (1) See page 70 for installation tool requirements.
- (2) Threads are gaugeable to within 2 pitches of the "S" Max. dimension. A class 3B/5H maximum material commercial nut shall pass up to the "S" Max. dimension.

# SELF-CLINCHING STUDS AND PINS

## HFH™/HFHS™/HFHB™ HEAVY-DUTY STUDS

- HFH studs are for high-strength applications in sheets as thin as .050" / 1.3 mm.
- HFHS studs offer high corrosion resistance.
- HFHB studs are for superior electrical/mechanical attachment in copper.
- HFH studs are recommended for use in steel or aluminum sheets HRB (Rockwell "B" Scale) 85 / HB (Hardness Brinell) 165 or less.
- HFHS studs are recommended for use in steel or aluminum sheets HRB (Rockwell "B" Scale) 70 / HB (Hardness Brinell) 125 or less.
- HFHB studs are recommended for use in copper sheets HRB (Rockwell "B" Scale) 55 / HB (Hardness Brinell) 83 or less.

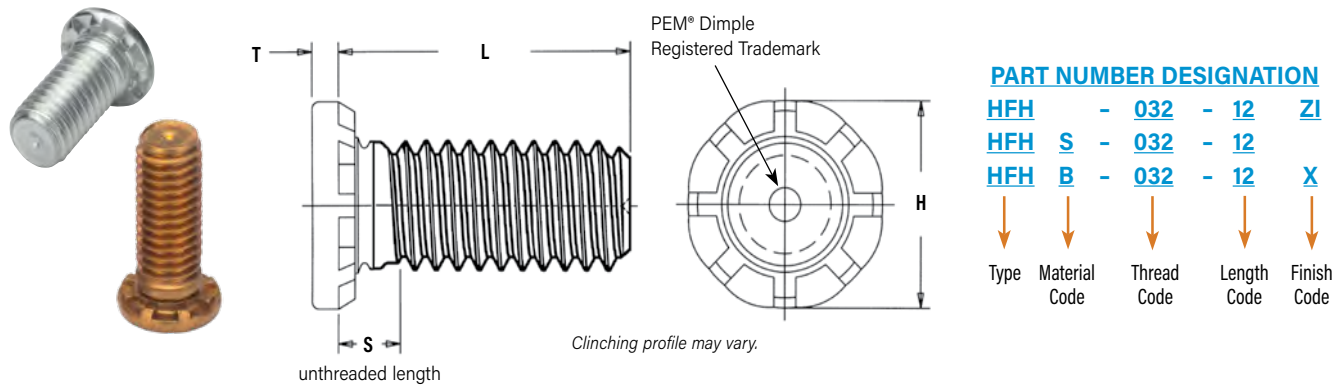

All dimensions are in inches.

UNIFIED	Thread Size	Type			Thread Code	Length Code "L" ±.015 (Length Code in 16ths of an inch)						Min. Sheet Thickness (2)	Hole Size in Sheet +.005 -0.000	H ±.01	S Max. (3)	T Max.	Max. Hole in Attached Parts	Min. Dist. Hole ⌀ to Edge	
		Fastener Material				.500	.750	1.00	1.25	1.50	1.75								2.00
		Steel	Stainless Steel	Phosphor Bronze (1)															
	.190-32 (#10-32)	HFH	HFHS	HFHB	032	8	12	16	20	24	28	32	.050	.190	.300	.105	.040	.252	.415
	.250-20 (1/4-20)	HFH	HFHS	HFHB	0420	8	12	16	20	24	28	32	.060	.250	.380	.125	.050	.312	.460
	.313-18 (5/16-18)	HFH	HFHS	HFHB	0518	8	12	16	20	24	28	32	.075	.312	.480	.140	.070	.374	.500
	.375-16 (3/8-16)	HFH	HFHS	HFHB	0616	—	12	16	20	24	28	32	.090	.375	.580	.155	.085	.437	.530

Tensile strength: HFH - 120 ksi / HFHS - 75 ksi / HFHB - 60 ksi.

All dimensions are in millimeters.

METRIC	Thread Size x Pitch	Type			Thread Code	Length code "L" ±0.4 (Length Code in millimeters)						Min. Sheet Thickness (2)	Hole Size in Sheet +0.13	H ±0.25	S Max. (3)	T Max.	Max. Hole in Attached Parts	Min. Dist. Hole ⌀ to Edge	
		Fastener Material				15	20	25	30	35	40								50
		Steel	Stainless Steel	Phosphor Bronze(1)															
	M5 x 0.8	HFH	HFHS	HFHB	M5	15	20	25	30	35	40	50	1.3	5	7.8	2.7	1.14	6.4	10.7
	M6 x 1	HFH	HFHS	HFHB	M6	15	20	25	30	35	40	50	1.5	6	9.4	2.8	1.27	7.5	11.5
	M8 x 1.25	HFH	HFHS	HFHB	M8	15	20	25	30	35	40	50	2	8	12.5	3.5	1.7	9.5	12.7
	M10 x 1.5	HFH	HFHS	HFHB	M10	15	20	25	30	35	40	50	2.3	10	15.7	4.1	2.29	11.5	13.7

Tensile strength: HFH - 900 MPa / HFHS - 515 MPa / HFHB - 415 MPa.

- The electrical resistance (tested at 10 amps DC) between phosphor bronze studs and copper busbars is below 104μ ohms and 62μ ohms for the #10-32 / M5 and 3/8-16 / M10 thread sizes respectively, after repeated thermal and mechanical cycling. For complete electrical resistance test data for type HFHB studs installed in copper, see bulletin entitled "Electrical Resistance of HFHB Studs Installed in Copper" on our website.
- See page 72 for installation tool requirements.
- Threads are gaugeable to within 2 pitches of the "S" Max. dimension. A class 3B/5H maximum material commercial nut shall pass up to the "S" Max. dimension.



Get quote >>

Angic Global Solutions

1-888-872-0690 [www.angic.com](http://www.angic.com) 59

<https://www.AngicGlobal.com> Sales@AngicGlobal.com

# SELF-CLINCHING STUDS AND PINS

## HFE™/THFE™ HEAVY DUTY STUDS FOR THIN SHEETS

- Enlarged head diameter reduces stress on panel.
- Thicker head allows for larger hole in attached panels.
- Clinch design provides high-strength in sheets as thin as .031" / 0.8 mm.
- Recommended for use in steel or aluminum sheets HRB (Rockwell "B" Scale) 85 / HB (Hardness Brinell) 165 or less.

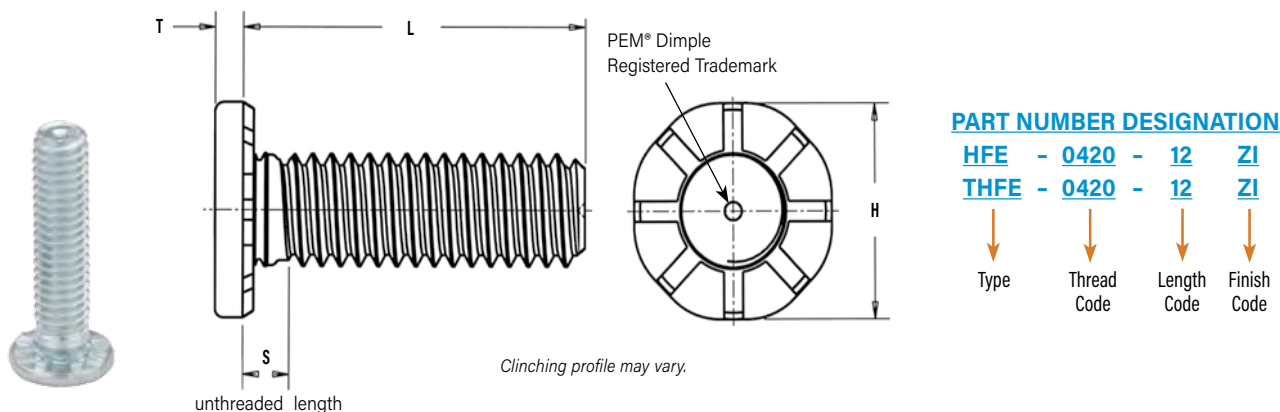

All dimensions are in inches.

UNIFIED	Thread Size (#10-32)	Type	Thread Code	Length Code "L" ±.015 (Length Code in 16ths of an inch)						Min. Sheet Thickness (1)	Hole Size In Sheet +.005 -.000	H ±.01	S Max. (2)	T Max.	Max. Hole in Attached Parts	Min. Dist. Hole To Edge	
		Fastener Material		.500	.750	1.00	1.25	1.50	1.75								2.00
		Steel															
	.190-32 (#10-32)	HFE	032	8	12	16	20	24	28	32	.040	.190	.357	.102	.048	.280	.360
	.250-20 (1/4-20)	HFE	0420	8	12	16	20	24	28	32	.040	.250	.462	.118	.060	.340	.470
		THFE									.031		.109	.069	.446		
	.313-18 (5/16-18)	HFE	0518	8	12	16	20	24	28	32	.060	.312	.586	.133	.083	.402	.560
		THFE									.031		.117	.099	.596		

Tensile strength: 120 ksi

All dimensions are in millimeters.

METRIC	Thread Size x Pitch	Type	Thread Code	Length Code "L" ±0.4 (Length Code in millimeters)						Min. Sheet Thickness (1)	Hole Size In Sheet +0.13	H ±0.25	S Max. (2)	T Max.	Max. Hole in Attached Parts	Min. Dist. Hole To Edge	
		Fastener Material		15	20	25	30	35	40								50
		Steel															
	M5 x 0.8	HFE	M5	15	20	25	30	35	40	50	1	5	9.6	2.6	1.35	7.3	10
	M6 x 1	HFE	M6	15	20	25	30	35	40	50	1	6	11.35	2.8	1.52	8.3	11.5
		THFE									0.8		2.62	1.7	10.5		
	M8 x 1.25	HFE	M8	15	20	25	30	35	40	50	1.5	8	15.3	3.3	2.13	10.3	14.5
		THFE									0.8		2.9	2.54	15		

Tensile strength: 900 MPa

- See page 71 for installation tool requirements.
- Threads are gaugeable to within 2 pitches of the "S" Max. dimension. A class 3B/5H maximum material commercial nut shall pass up to the "S" Max. dimension.

# SELF-CLINCHING STUDS AND PINS

## HFG8™/HF109™ HEAVY DUTY, HIGH TENSILE STRENGTH STUDS

- HFG8 and HF109 studs are for heavy-duty applications in sheets as thin as .040" / 1 mm.
- Grade 8 and property class 10.9 studs meeting 150 ksi/1040 MPa minimum.
- Recommended for use in steel or HSLA steel sheets HRB (Rockwell "B" Scale) 89 / HB (Hardness Brinell) 180 or less.
- Large head diameter spreads compressive stress on panel.

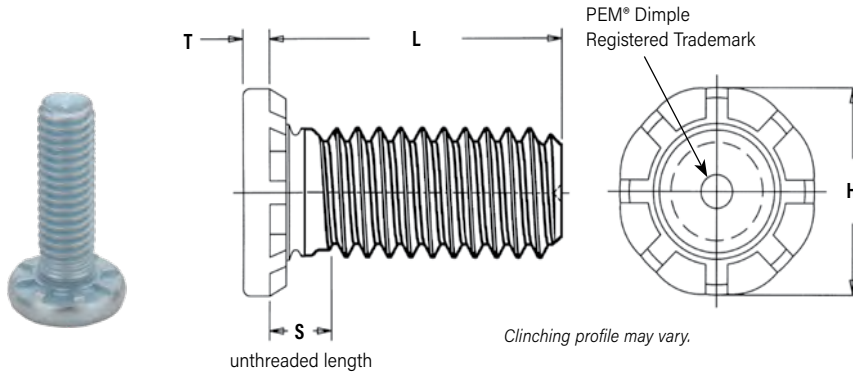

### PART NUMBER DESIGNATION

HF	G8	-	0420	-	12	ZI
HF	109	-	M6	-	20	ZI
↓	↓	↓	↓	↓	↓	↓
Type	Strength Code		Thread Code		Length Code	Finish Code

All dimensions are in inches.

UNIFIED	Thread Size	Type	Thread Code	Length Code "L" ±.015 (1) (Length Code in 16ths of an inch)			Min. Sheet Thickness (2)	Hole Size in Sheet +.005 -.000	H ±.01	S Max. (3)	T Max.	Max. Hole in Attached Parts	Min. Dist. Hole C/L To Edge
		Steel		.500	.750	1.00							
	.190-32 (#10-32)	HFG8	032	8	12	16	.040	.190	.391	.105	.077	.280	.469
.250-20 (1/4-20)	HFG8	0420	8	12	16	.040	.250	.507	.125	.090	.340	.709	
.313-18 (5/16-18)	HFG8	0518	—	12	16	.060	.312	.645	.140	.126	.402	.827	

Tensile strength: 150 ksi

All dimensions are in millimeters.

METRIC	Thread Size x Pitch	Type	Thread Code	Length Code "L" ±0.4 (1) (Length Code in millimeters)			Min. Sheet Thickness (2)	Hole Size in Sheet +.013	H ±0.25	S Max. (3)	T Max.	Max. Hole in Attached Parts	Min. Dist. Hole C/L To Edge
		Steel		15	20	25							
M5 x 0.8	HF109	M5	15	20	25	1	5	10.3	2.6	2.06	7.3	11.5	
M6 x 1	HF109	M6	15	20	25	1	6	12.1	2.7	2.29	8.3	18.0	
M8 x 1.25	HF109	M8	—	20	25	1.5	8	16.6	3.4	3.25	10.3	21.0	

Tensile strength: 1040 MPa

(1) Other lengths available up to a maximum of 1.5" (unified) and 40 mm (metric) on special order.

(2) See page 72 for installation tool requirements.

(3) Threads are gaugeable to within 2 pitches of the "S" Max. dimension. A class 3B/5H maximum material commercial nut shall pass up to the "S" Max. dimension.

To be sure that you are getting genuine PEM products, look for the PEM stamp. Studs within the size range of the SAE and ISO specs are also identified with the Grade 8 and 10.9 head markings respectively.

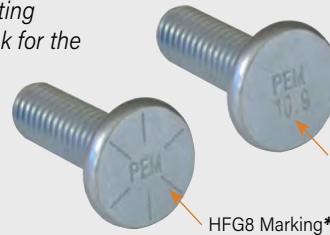

\* Thread size #10-32 does not have SAE head marking since it is technically not within the size range of the specification.



Get quote >>

Angic Global Solutions

1-888-872-0690 [www.angic.com](http://www.angic.com) 61

<https://www.AngicGlobal.com> Sales@AngicGlobal.com

# SELF-CLINCHING STUDS AND PINS

## HFLH™ HARD PANEL STUDS

- Installs into thinner, harder, high strength steel materials
- Recommended for use in HSLA sheets up to 700 MPa ultimate (hardness up to 96 HRB) such as s500 <sup>(1)</sup>

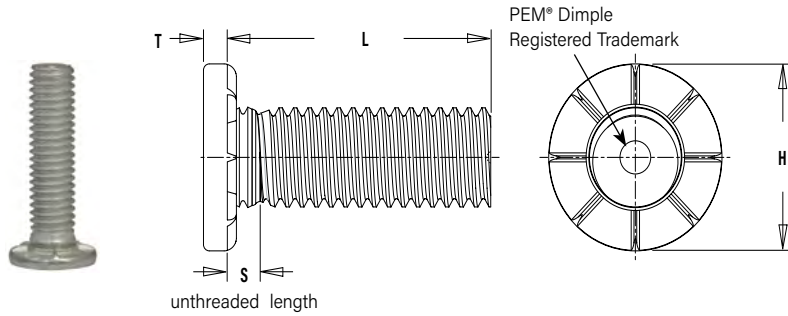

### PART NUMBER DESIGNATION

**HFLH - 0420 - 20 ZI**

↓                      ↓                      ↓                      ↓

Type                      Thread Code                      Length Code                      Finish Code

All dimensions are in inches.

UNIFIED	Thread Size	Type	Thread Code	Length Code "L" ±.015 (Length Code in 16ths of an inch)						Min. Sheet Thickness (2)	Hole Size In Sheet +.005 -.000	H ±.01	S Max. (3)	T Max.	Max. Hole in Attached Parts	Min. Dist. Hole $\varnothing$ To Edge	
		Fastener Material		.500	.750	1.00	1.25	1.50	1.75								2.00
		Hardened Alloy Steel															
	.190-32 (#10-32)	HFLH	032	8	12	16	20	24	28	32	.040	.190	.357	.102	.048	.280	.360
	.250-20 (1/4-20)	HFLH	0420	8	12	16	20	24	28	32	.040	.250	.462	.118	.060	.340	.470
	.313-18 (5/16-18)	HFLH	0518	8	12	16	20	24	28	32	.060	.312	.586	.133	.083	.402	.560

Tensile strength: 120 ksi

All dimensions are in millimeters.

METRIC	Thread Size x Pitch	Type	Thread Code	Length Code "L" ±.04 (Length Code in millimeters)						Min. Sheet Thickness (2)	Hole Size In Sheet +0.13	H ±0.25	S Max. (3)	T Max.	Max. Hole in Attached Parts	Min. Dist. Hole $\varnothing$ To Edge	
		Fastener Material		15	20	25	30	35	40								50
		Hardened Alloy Steel															
	M5 x 0.8	HFLH	M5	15	20	25	30	35	40	50	1	5	9.6	2.6	1.35	7.3	10
	M6 x 1	HFLH	M6	15	20	25	30	35	40	50	1	6	11.35	2.8	1.52	8.3	11.5
	M8 x 1.25	HFLH	M8	15	20	25	30	35	40	50	1.5	8	15.3	3.3	2.13	10.3	14.5

Tensile strength: 900 MPa

- Material meeting specification DIN EN 10149-2, grade S500MC with minimum yield of 500 MPa and max tensile of 700 MPa is a typical panel material in which type HFLH studs can be used.
- See page 71 for installation tool requirements.
- Threads are gaugeable to within 2 pitches of the "S" Max. dimension. A class 3B/5H maximum material commercial nut shall pass up to the "S" Max. dimension.

# SELF-CLINCHING STUDS AND PINS

## SGPC™ SWAGING COLLAR STUDS

- Installs into sheets as thin as .024" / 0.6 mm.
- Can be used to attach dissimilar materials.
- Can captivate multiple panels as long as the total thickness does not exceed the maximum sheet thickness.<sup>(1)</sup>
- Can be installed into most materials, including stainless steel and rigid non-metallic panels.
- Allows for close centerline-to-edge distance.

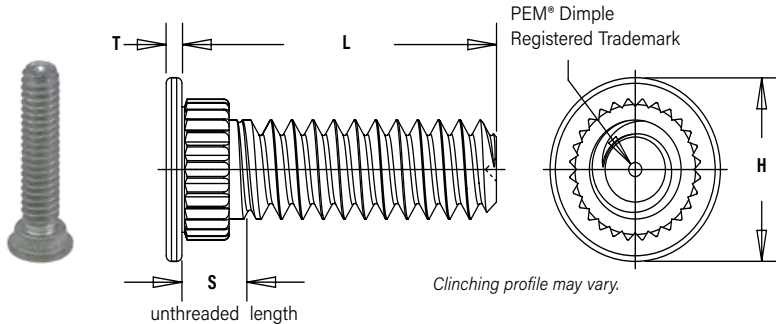

### PART NUMBER DESIGNATION

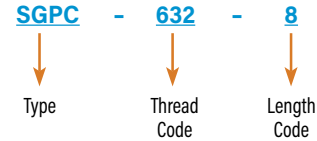

All dimensions are in inches.

UNIFIED	Thread Size	Type	Thread Code	Length Code "L" ±.015 (Length Code in 16ths of an inch)								Sheet Thickness (2)	Hole Size in Sheet +.003 -.000	H ±.010	S Max. (3)	T ±.004	Hole Dia. of Attached Panel +.005 -.000	Min. Dist. Hole ⌀ To Edge	
		Fastener Material		.312	.375	.500	.625	.750	.875	1.00	1.25								1.50
		Stainless Steel																	
	.086-56 (#2-56)	SGPC	256	5	6	8	10	12	—	—	—	.024 - .047	.145	.189	.093	.020	.182	.130	
	.112-40 (#4-40)	SGPC	440	5	6	8	10	12	14	16	20	.024 - .047	.171	.228	.101	.024	.205	.160	
	.138-32 (#6-32)	SGPC	632	5	6	8	10	12	14	16	20	24	.024 - .047	.196	.256	.109	.024	.229	.180
	.164-32 (#8-32)	SGPC	832	5	6	8	10	12	14	16	20	24	.024 - .047	.223	.279	.109	.024	.259	.200
	.190-32 (#10-32)	SGPC	032	5	6	8	10	12	14	16	20	24	.024 - .047	.249	.307	.109	.024	.280	.210
	.250-20 (1/4-20)	SGPC	0420	—	6	8	10	12	14	16	20	24	.024 - .047	.309	.366	.131	.028	.343	.250

All dimensions are in millimeters.

METRIC	Thread Size x Pitch	Type	Thread Code	Length Code "L" ±0.4 (Length Code in millimeters)								Sheet Thickness (2)	Hole Size in Sheet +0.08	H ±0.25	S Max. (3)	T ±0.1	Hole Dia. of Attached Panel +0.13	Min. Dist. Hole ⌀ To Edge	
		Fastener Material		8	10	12	15	18	—	—	—								—
		Stainless Steel																	
	M2.5 x 0.45	SGPC	M2.5	8	10	12	15	18	—	—	—	—	0.6 - 1.2	4	5	2.4	0.5	4.95	3.9
	M3 x 0.5	SGPC	M3	8	10	12	15	18	20	25	—	—	0.6 - 1.2	4.5	6	2.5	0.6	5.45	4.3
	M4 x 0.7	SGPC	M4	8	10	12	15	18	20	25	30	—	0.6 - 1.2	5.5	7	2.7	0.6	6.3	4.9
	M5 x 0.8	SGPC	M5	8	10	12	15	18	20	25	30	35	0.6 - 1.2	6.5	8	2.8	0.6	7.45	5.5
	M6 x 1	SGPC	M6	—	10	12	15	18	20	25	30	35	0.6 - 1.2	7.5	9	3	0.7	8.3	6.2

- When using the fastener to attach more than one sheet or panel, the stud may seem slightly loose after installation. This is a normal condition in some applications and will not effect the stud's performance.
- See page 73 for installation tooling requirements. Contact Technical Support (techsupport@pemnet.com) for other thicknesses.
- Threads are gaugeable to within 2 pitches on the "S" Max. dimension. A class 3B/5H maximum material commercial nut shall pass up to the "S" Max. dimension.



Get quote >>

Angic Global Solutions

1-888-872-0690 [www.angic.com](http://www.angic.com) 63

<https://www.AngicGlobal.com> Sales@AngicGlobal.com

# SELF-CLINCHING STUDS AND PINS

## FHX™ FLUSH-HEAD STUDS WITH X-PRESS™ THREAD PROFILE FOR USE WITH PUSH ON PLASTIC MATING FASTENERS

- Offers fast, reliable attachment.
- Coarse thread design of the thread reduces assembly time and provides high retention force.
- Allows for lighter assembly.
- Self-clinching stud mounts flush in metal sheets as thin as 1mm.
- Thread design accommodates paints and coatings without compromising performance.
- Self-clinching technology is cleaner and has a more attractive finished appearance than welding.
- Can be installed during the stamping process with PEMSERTER® in-die technology.

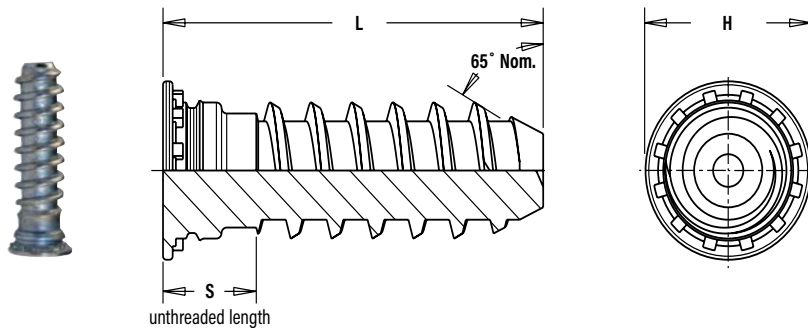

### PART NUMBER DESIGNATION

**FH** - **X5** - **10** **ZI**

↓                      ↓                      ↓                      ↓

Type                      Thread Code                      Length Code                      Finish Code

All dimensions are in millimeters.

Thread Size x Pitch	Type	Thread Code	Length Code "L" ±0.4 (Length Code in millimeters)				Min. Sheet Thickness	Hole Size in Sheet +0.08	H ±0.4	S Max.
			10	15	20	25				
5 mm x 1.6	FH	X5	10	15	20	25	1	5.2	6.5	4
6 mm x 1.6	FH	X6	10	15	20	25	1.6	6.2	8.2	4

(1) See page 73 for installation tool requirements.

**Examples of plastic nuts and wire tie products that can be used with PEM® X-Press™ studs.**

**Contact Tech Support for more information.**

**Press-on (kwik) nut can be used to hold down soft materials such as foam, cloth or insulation.**



# SELF-CLINCHING STUDS AND PINS

## FH™/FHS™/FHA™ FLUSH-HEAD PINS

- Flush-head for sheet thickness of .040" / 1 mm and greater.
- FH pins are recommended for use in steel or aluminum sheets HRB (Rockwell "B" Scale) 80 / HB (Hardness Brinell) 150 or less.
- FHS pins are recommended for use in steel or aluminum sheets HRB (Rockwell "B" Scale) 70 / HB (Hardness Brinell) 125 or less.
- FHA pins are recommended for use in aluminum sheets HRB (Rockwell "B" Scale) 50 / HB (Hardness Brinell) 82 or less.

These PEM® pins are only available on special order. See TPS, TP4, and TPXS pins on page 16 for standard diameter pins.

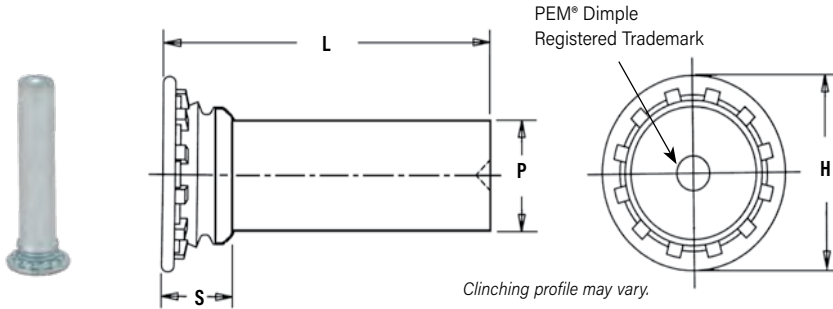

### PART NUMBER DESIGNATION

FH	-	094	-	6	ZI
FH	S	-	094	-	6
FH	A	-	094	-	6
↓	↓	↓	↓	↓	↓
Type	Material Code	Pin Diameter Code	Length Code	Finish Code	

All dimensions are in inches.

UNIFIED	Nominal Pin Diameter P±.002	Type			Pin Dia. Code	Length Code "L" ±.015 (Length Code in 16ths of an inch)										Min. Sheet Thickness (1)	Hole Size in Sheet +.003 -0.000	H ±.015	S Max. (2)	Min. Dist. Hole to Edge
		Fastener Material				.250	.312	.375	.500	.625	.750	.875	1.00	1.25	1.50					
		Steel	Stainless Steel	Aluminum																
.073	FH	FHS	FHA	073	4	5	6	8	10	-	-	-	-	-	.040	.085	.15	.075	.19	
.084	FH	FHS	FHA	084	4	5	6	8	10	12	-	-	-	-	.040	.099	.16	.085	.22	
.094	FH	FHS	FHA	094	4	5	6	8	10	12	-	-	-	-	.040	.111	.18	.085	.22	
.103	FH	FHS	FHA	103	4	5	6	8	10	12	-	-	-	-	.040	.118	.18	.085	.22	
.106	FH	FHS	FHA	106	4	5	6	8	10	12	14	16	20	-	.040	.125	.19	.090	.22	
.116	FH	FHS	FHA	116	4	5	6	8	10	12	14	16	20	-	.040	.137	.21	.090	.25	
.120	FH	FHS	FHA	120	4	5	6	8	10	12	14	16	20	24	.040	.137	.21	.090	.25	
.137	FH	FHS	FHA	137	4	5	6	8	10	12	14	16	20	24	.040	.157	.23	.090	.28	
.141	FH	FHS	FHA	141	4	5	6	8	10	12	14	16	20	24	.040	.163	.24	.090	.28	
.160	FH	FHS	FHA	160	4	5	6	8	10	12	14	16	20	24	.040	.189	.26	.100	.28	
.167	FH	FHS	FHA	167	-	5	6	8	10	12	14	16	20	24	.040	.189	.26	.100	.28	
.173	FH	FHS	FHA	173	-	5	6	8	10	12	14	16	20	24	.040	.197	.26	.100	.28	
.207	FH	FHS	FHA	207	-	5	6	8	10	12	14	16	20	24	.062	.236	.32	.135	.31	
.215	FH	FHS	FHA	215	-	-	-	8	10	12	14	16	20	24	.062	.250	.34	.135	.31	
.223	FH	FHS	FHA	223	-	-	-	8	10	12	14	16	20	24	.062	.250	.34	.135	.31	
.273	FH	FHS	FHA	273	-	-	-	8	10	12	14	16	20	24	.093	.312	.38	.160	.38	
.281	FH	FHS	FHA	281	-	-	-	8	10	12	14	16	20	24	.093	.312	.38	.160	.38	

All dimensions are in millimeters.

METRIC	Nominal Pin Diameter P±0.05	Type			Pin Dia. Code	Length Code "L" ±0.4 (Length Code in millimeters)										Min. Sheet Thickness (1)	Hole Size in Sheet +0.08	H ± 0.4	S Max. (2)	Min. Dist. Hole to Edge
		Fastener Material				6	8	10	12	15	18	20	25	30	35					
		Steel	Stainless Steel	Aluminum																
3	FH	FHS	FHA	3MM	6	8	10	12	15	18	20	25	30	-	1	3.5	5.3	2.3	6.4	
4	FH	FHS	FHA	4MM	-	8	10	12	15	18	20	25	30	35	1	4.1	6	2.3	7.1	
5	FH	FHS	FHA	5MM	-	8	10	12	15	18	20	25	30	35	1	5.5	7.5	2.55	7.6	

(1) See page 74 for installation tool requirements.

(2) Pin diameter may exceed max. in this region.



Get quote >>

Angic Global Solutions

1-888-872-0690 [www.angic.com](http://www.angic.com) 65

<https://www.AngicGlobal.com> Sales@AngicGlobal.com

# SELF-CLINCHING STUDS AND PINS

## TPS™/TP4™ FLUSH-HEAD PILOT PINS

- Flush-head for sheet thickness of .040" / 1 mm and greater.
- Satisfies a wide range of positioning, pivot, and alignment applications.
- Chamfered end makes mating hole location easy.
- TPS pins are recommended for use in steel or aluminum sheets HRB (Rockwell "B" Scale) 70 / HB (Hardness Brinell) 125 or less.
- TP4 pins are recommended for use in stainless steel sheets HRB (Rockwell "B" Scale) 92 / HB (Hardness Brinell) 195 or less.

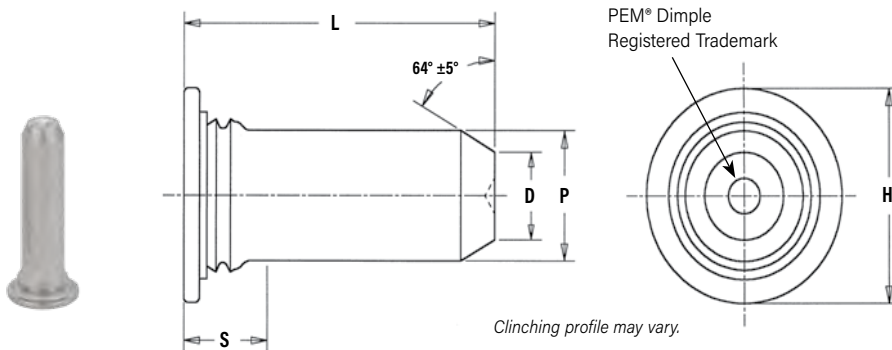

### PART NUMBER DESIGNATION

TP	S	-	187	-	8
TP	4	-	187	-	8
↓	↓		↓		↓
Type	Material Code		Pin Diameter Code		Length Code

All dimensions are in inches.

UNIFIED	Pin Diameter P ± .002	Type		Pin Diameter Code	Length Code "L" ± .015 (Length Code in 16ths of an inch)					Min. Sheet Thickness (1)	Hole Size in Sheet +.003 -.000	D ±.006	H ±.015	S Max. (2)	Min. Distance Hole $\varnothing$ to Edge
		Fastener Material			.375	.500	.625	.750	1.00						
		300 Series Stainless Steel	400 Series Stainless Steel												
	.125	TPS	TP4	125	6	8	10	12	—	.040	.144	.090	.205	.090	.250
	.187	TPS	TP4	187	6	8	10	12	16	.040	.205	.132	.270	.090	.280
	.250	TPS	TP4	250	—	8	10	12	16	.040	.272	.177	.335	.090	.310

All dimensions are in millimeters.

METRIC	Pin Diameter P ± 0.05	Type		Pin Diameter Code	Length Code "L" ± 0.4 (Length Code in millimeters)					Min. Sheet Thickness (1)	Hole Size in Sheet +0.08	D ±0.15	H ±0.4	S Max. (2)	Min. Distance Hole $\varnothing$ to Edge	
		Fastener Material			6	8	10	12	16							
		300 Series Stainless Steel	400 Series Stainless Steel													
	3	TPS	TP4	3MM	6	8	10	12	16	—	1	3.5	2.11	5.2	2.29	6.4
	4	TPS	TP4	4MM	6	8	10	12	16	—	1	4.5	2.82	6.12	2.29	7.1
	5	TPS	TP4	5MM	—	—	10	12	16	20	1	5.5	3.53	7.19	2.29	7.6
	6	TPS	TP4	6MM	—	—	—	12	16	20	1	6.5	4.24	8.13	2.29	7.9

- (1) See page 75 for installation tool requirements.  
 (2) Pin diameter may exceed max. in this region.

**If your application requires corrosion resistant fasteners, non-magnetic fasteners, or will be exposed to temperatures above 300° F (149° C), see note at bottom of page 6 about "400 series fasteners for stainless steel panels"**

## TPXS™ SELF-CLINCHING PILOT PINS

- Meets the ATCA PICMG 3.0 specification.
- 15° tapered point makes engaging the mating hole easy.



Min. Sheet Thickness: 1 mm  
 Hole Size In Sheet: 3.5 mm +0.08  
 Min. Dist. Hole C/L To Edge: 6.4 mm

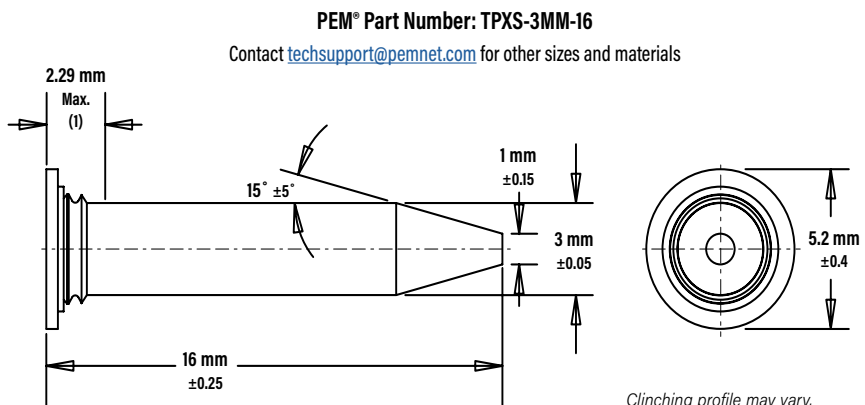

(1) Pin diameter may exceed max. in this region.

PEM® Part Number: TPXS-3MM-16

Contact [techsupport@pemnet.com](mailto:techsupport@pemnet.com) for other sizes and materials

# SELF-CLINCHING STUDS AND PINS

## MATERIAL AND FINISH SPECIFICATIONS

Type	Threads (1)	Fastener Materials							Standard Finishes			Optional Finishes (2)		
	External, ASME B1.1, 2A / ASME B1.13M, 6g	Hardened Carbon Steel	Hardened Medium Carbon Alloy Steel	Aluminum (plain finish)	CDA 510 Phosphor Bronze	Age Hardened A286 Stainless Steel	300 Series Stainless Steel	400 Series Stainless Steel	No Finish (4)	Zinc plated per ASTM B633, SC1 (5µm), Type III, Colorless, (5)	Passivated and/or Tested Per ASTM A380	Zinc Plated per ASTM B633, SC1 (5µm), Type II, Yellow, (5)	No Finish (4)	Rust Preventative Oil
FH	▪	▪								▪	▪			
FHS	▪						▪				▪			
FHA	▪			▪					▪ (3)					
FH4	▪							▪			▪			
FHP	▪					▪					▪			
FHL	▪	▪									▪			
FHLS	▪						▪				▪			
TFH	▪	▪									▪			
TFHS	▪						▪				▪			
HFE	▪	▪									▪			
THFE	▪	▪									▪			
HFH	▪	▪									▪			
HFHB	▪				▪					▪				
HFHS	▪						▪				▪			
HFG8	▪		▪								▪			
HF109	▪		▪								▪			
HFLH	▪		▪								▪	▪ (6)		
SGPC	▪						▪				▪			
FHX		▪									▪		▪	
TPS							▪				▪			
TP4								▪			▪			
TPXS							▪				▪			
Part Number Codes for Finishes									X	ZI	None	ZC	X	X

Type	For use in Sheet Hardness (7)								
	HRB 50 / HB 82 or Less	HRB 55 / HB 83 or Less	HRB 70 / HB 125 or Less	HRB 80 / HB 150 or Less	HRB 85 / HB 165 or Less	HRB 89 / HB 180 or Less	HRB 92 / HB 202 or Less	HRB 96 / HB 216 or Less	Any Sheet Hardness
FH				▪					
FHS			▪						
FHA	▪								
FH4							▪		
FHP							▪		
FHL				▪					
FHLS			▪						
TFH				▪					
TFHS			▪						
HFE					▪				
THFE					▪				
HFH					▪				
HFHB		▪							
HFHS			▪						
HFG8						▪			
HF109						▪			
HFLH								▪	
SGPC									▪
FHX				▪					
TPS			▪						
TP4							▪		
TPXS			▪						

- (1) For plated studs, Class 2A/6g, the maximum major and pitch diameter, after plating, may equal basic sizes and be gauged to Class 3A/4h. Per ASME B1.1, Section 7, Paragraph 7.2 and ASME B1.13M, Section 8, paragraph 8.2.
- (2) Special order with additional charge.
- (3) Part numbers for aluminum studs have no finish suffix.
- (4) "X" suffix studs may have pitch diameters and major diameters below 2A/6g minimum size, per ANSI B1.1, Section 7, and B1.13M, Section 8 to allow for minimum of 0.0002" / 0.0051 mm of plating.
- (5) See [PEM Technical Support](#) section of our web site for related plating standards and specifications.
- (6) With rust preventative oil.
- (7) HRB - Hardness Rockwell "B" Scale. HB - Hardness Brinell.



Get quote »

Angic Global Solutions

1-888-872-0690 [www.angic.com](http://www.angic.com) 67

<https://www.AngicGlobal.com> Sales@AngicGlobal.com

# SELF-CLINCHING STUDS AND PINS

## INSTALLATION - FH™/FHS™/FHA™ THREADED STUDS

1. Prepare properly sized mounting hole in sheet. Do not perform any secondary operations such as deburring.
2. Insert stud through mounting hole (punch side) of sheet and into anvil hole.
3. With punch and anvil surfaces parallel, apply squeezing force to embed the head of the stud flush in the sheet. In most cases, when using sheets .060" / 1.51 mm and thicker, the anvil requires only a straight thru hole to accommodate the stud (see illustrations below for details). For sheets less than .060 / 1.51 mm, the hole requires a countersink with dimension A at the top to provide for metal flow around the shank of the stud.

Tooling for sheet thicknesses less than .060 / 1.51 mm with #2 thru #10 / M2.5 thru M5 thread sizes and less than .093" / 2.36 mm for 1/4" / M6 threads.

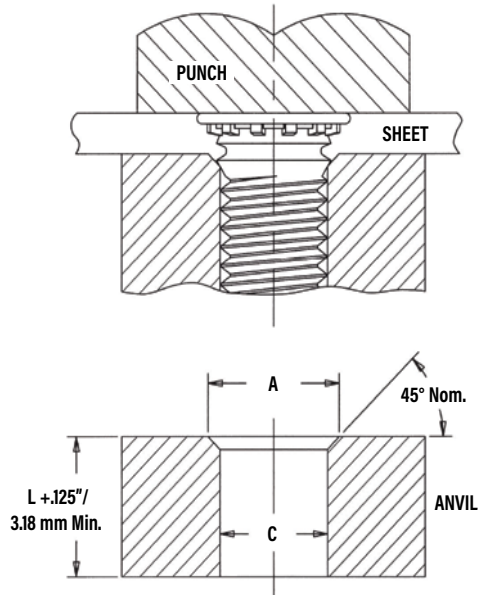

Tooling for sheet thicknesses .060" / 1.51 mm and greater with #2 thru #10 / M2.5 thru M5 thread sizes and .093" / 2.36 mm and greater for 1/4" and 5/16" / M6 and M8 threads.

See page 55 for "L"

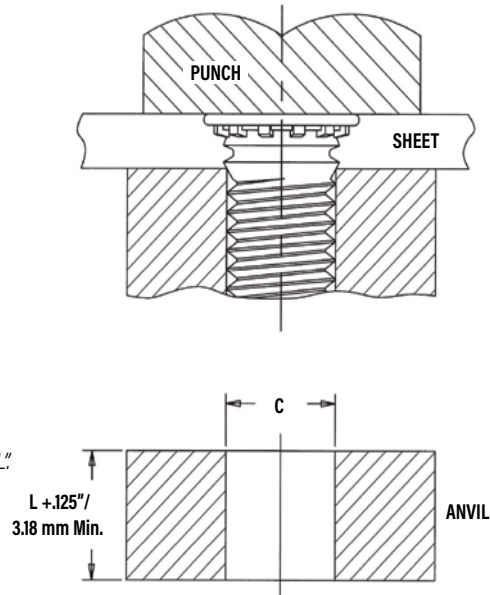

### PEMSERTER® Installation Tooling

	Thread Code	Anvil Dimensions (in.)		Anvil Part No. For Sheets > .060"	Anvil Part No. For Sheets ≤ .059"	Punch Part Number
		A	C			
UNIFIED	256	.110-.114	.087-.090	970200005300	970200240300	975200048
	440	.136-.140	.113-.116	970200006300	970200241300	
	632	.162-.166	.139-.142	970200007300	970200243300	
	832	.188-.192	.165-.168	970200008300	970200245300	
	024/032	.216-.220	.191-.194	970200009300	970200246300	
				For Sheets > .093"	For Sheets ≤ .092"	
	0420	.295-.300	.250-.253	970200010300	970200249300	975200048
	0518	.334-.338	.3125-.3155	970200011300	-	

	Thread Code	Anvil Dimensions (mm)		Anvil Part No. For Sheets > 1.51 mm	Anvil Part No. For Sheets ≤ 1.5 mm	Punch Part Number		
		A + 0.1	C + 0.08					
METRIC	M2.5	3.1	2.53	970200300300	970200493300	975200048		
	M3	3.6	3.03	970200229300	970200242300			
	M3.5	4.1	3.53	970200007300	970200243300			
	M4	4.6	4.03	970200019300	970200244300			
	M5	5.6	5.03	970200020300	970200247300			
				For Sheets > 2.36 mm	For Sheets ≤ 2.36 mm			
		M6	6.6	6.03	970200230300		970200248300	975200048
		M8	8.6	8.03	970200231300		-	

# SELF-CLINCHING STUDS AND PINS

## INSTALLATION - FH4™/FHP™ STUDS FOR STAINLESS STEEL SHEETS

1. Prepare properly sized mounting hole in sheet. Do not perform any secondary operations such as deburring.
2. Insert stud through mounting hole (punch side) of sheet and into anvil hole.
3. With punch and anvil surfaces parallel, apply squeezing force to embed the head of the stud flush in the sheet.

For FH4/FHP studs, a special anvil with a raised ring is required to create a proper installation. The raised ring acts as a second displacer of the stainless sheet material, thereby ensuring that the annular groove is filled. Please see page 56 for recommended sheet thickness range. The special anvils are available from PEM stock or can be machined from suitable tool steel. A hardness of HRC 55 / HB 547 minimum is required to provide long anvil life. We recommend measuring the "P" dimension every 5000 installations to ensure that the anvil remains within specification.

### PEMSERTER® Installation Tooling

UNIFIED	Thread Code	Anvil Dimensions (in.)						Anvil Part Number	Punch Part Number
		A	B	C	P	R <sub>1</sub> Max.	R <sub>2</sub> Max.		
	440	.113	.144	.174	.010	.003	.005	8001645	975200048
632	.140	.170	.200	.010	.003	.005	8001644		
832	.166	.202	.236	.010	.003	.005	8001643		
032	.191	.235	.275	.010	.003	.005	8001642		
0420	.252	.324	.360	.020	.003	.005	8002535		

METRIC	Thread Code	Anvil Dimensions (mm)						Anvil Part Number	Punch Part Number
		A	B	C	P	R <sub>1</sub> Max.	R <sub>2</sub> Max.		
	M3	3.05	3.81	4.57	0.25	0.08	0.13	8001678	975200048
M4	4.04	4.95	5.82	0.25	0.08	0.13	8001677		
M5	5.08	6.15	7.16	0.25	0.08	0.13	8001676		
M6	6.05	7.87	8.79	0.51	0.08	0.13	8002536		

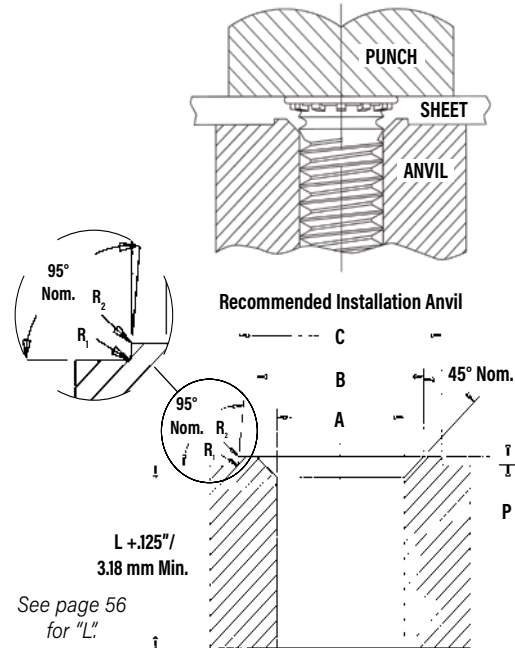

See page 56 for "L."

## INSTALLATION - FHL™/FHLs™ STUDS

1. Prepare properly sized mounting hole in sheet. Do not perform any secondary operations such as deburring.
2. Insert stud through mounting hole (punch side) of sheet and into anvil hole.
3. With punch and anvil surfaces parallel, apply squeezing force to embed the head of the stud flush in the sheet. For sheets .060" / 1.51 mm and thicker, the anvil requires only a straight thru hole to accommodate the stud. For sheets less than .060" / 1.51 mm, the hole requires a countersink with dimension A at the top to provide for metal flow around the shank of the stud.

Tooling for sheet thicknesses less than .060" / 1.51 mm.

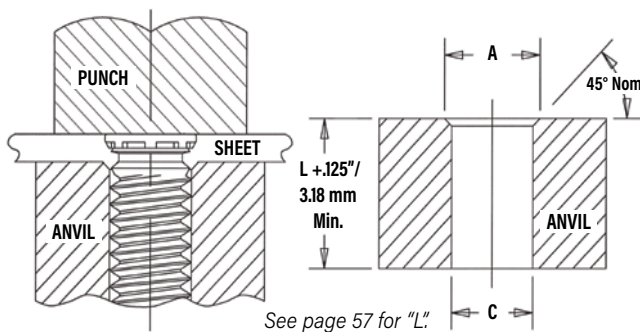

See page 57 for "L."

Tooling for sheet thicknesses .060" / 1.51 mm and greater.

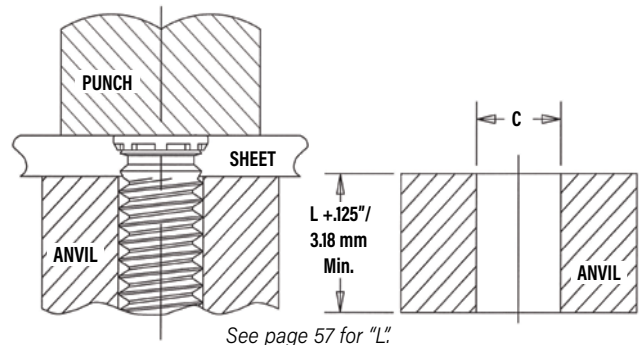

See page 57 for "L."

### PEMSERTER® Installation Tooling

UNIFIED	Thread Code	Anvil Dimensions (in.)		Anvil Part No. For Sheets > .060"	Anvil Part No. For Sheets ≤ .059"	Punch Part Number
		A	C			
	256	.110-.114	.087-.090	8003313	8003297	975200997
440	.136-.140	.113-.116	8003618	8003298		
632	.162-.166	.139-.142	8003314	8003299		
832	.188-.192	.165-.168	8003315	8003300		
032	.216-.220	.191-.194	8003619	8003301		

METRIC	Thread Code	Anvil Dimensions (mm)		Anvil Part No. For Sheets > 1.51 mm	Anvil Part No. For Sheets ≤ 1.5 mm	Punch Part Number
		A ±0.05	C +0.08			
	M2.5	3.1	2.53	8003316	8003302	975200997
M3	3.6	3.03	8003317	8003303		
M3.5	4.1	3.53	8003318	8003304		
M4	4.6	4.03	8003620	8003305		
M5	5.6	5.03	8003319	8003306		



Get quote

Angic Global Solutions

1-888-872-0690 [et.com](http://www.angic.com) 69

<https://www.AngicGlobal.com> Sales@AngicGlobal.com

# SELF-CLINCHING STUDS AND PINS

## INSTALLATION - TFH™/TFHS™ NON-FLUSH STUDS

1. Prepare properly sized mounting hole in sheet. Do not perform any secondary operations such as deburring.
2. Insert stud through mounting hole (punch side) of sheet and into anvil hole.
3. With punch and anvil surfaces parallel, apply squeezing force until the punch contacts the sheet. When installed, the stud head is not flush but will protrude approximately .025" / 0.64 mm. For sheets .030" / 0.76 mm and thicker, the anvil requires only a straight thru hole to accommodate the stud. For sheets less than .030" / 0.76 mm down to .020" / 0.51 mm, the hole requires a countersink with dimension A at the top to provide for metal flow around the shank of the stud. The standard punch design below provides clearance for the stud head and reduces chances of over squeezing the head of the stud into the sheet metal.

Tooling for sheet thicknesses less than .030" / 0.76 mm down to .020" / 0.51 mm.

Tooling for sheet thicknesses .030" / 0.76 mm and greater.

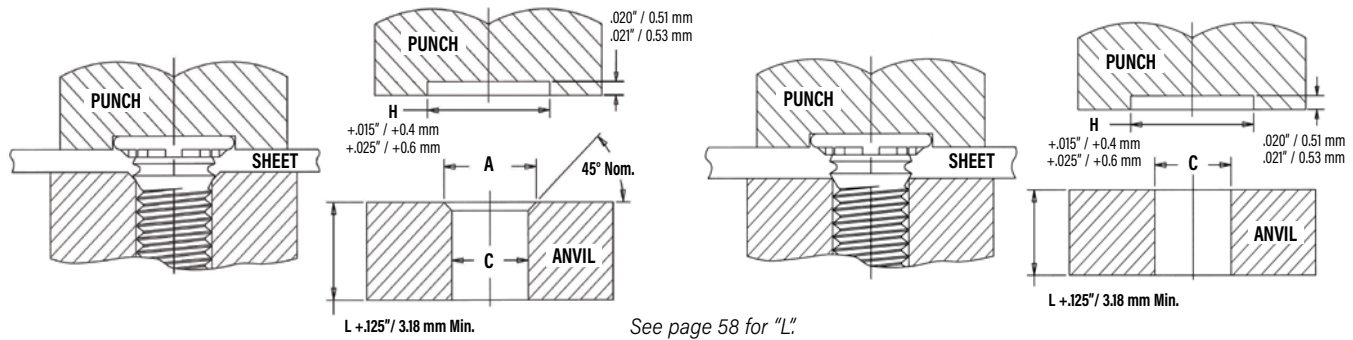

See page 58 for "L"

### PEMSERTER® Installation Tooling

UNIFIED	Thread Code	Anvil Dimensions (in.)		Anvil Part No. For Sheets > .030"	Anvil Part No. For Sheets .020" - .029"	Punch Part Number
		A	C			
	256	.110-.114	.087-.090	970200005300	970200240300	970200235400
	440	.136-.140	.113-.116	970200006300	970200241300	970200236400
	632	.162-.166	.139-.142	970200007300	970200243300	970200237400
	832	.188-.192	.165-.168	970200008300	970200245300	970200238400
	032	.216-.220	.191-.194	970200009300	970200246300	970200239400
	0420	.295-.300	.250-.253	970200010300	970200249300	970200496400

METRIC	Thread Code	Anvil Dimensions (mm)		Anvil Part No. For Sheets > 0.76 mm	Anvil Part No. For Sheets 0.51 - 0.75 mm	Punch Part Number
		A + 0.1	C + 0.08			
	M3	3.6	3.03	970200229300	970200242300	970200236400
	M3.5	4.1	3.53	970200007300	970200243300	970200237400
	M4	4.6	4.03	970200019300	970200244300	970200238400
	M5	5.6	5.03	970200020300	970200247300	970200239400
	M6	6.6	6.03	970200203000	970200248300	970200496400

## INSTALLATION - HFH™/HFHB™/HFHS™ STUDS

1. Prepare properly sized mounting hole in sheet. Do not perform any secondary operations such as deburring.
2. Insert stud through mounting hole (punch side) of sheet and into anvil hole.
3. With punch and anvil surfaces parallel, apply squeezing force on the punch sufficient only to embed the ribs on the head of the stud into the sheet. The standard punch design provides clearance for the stud head and reduces chances of over squeezing.

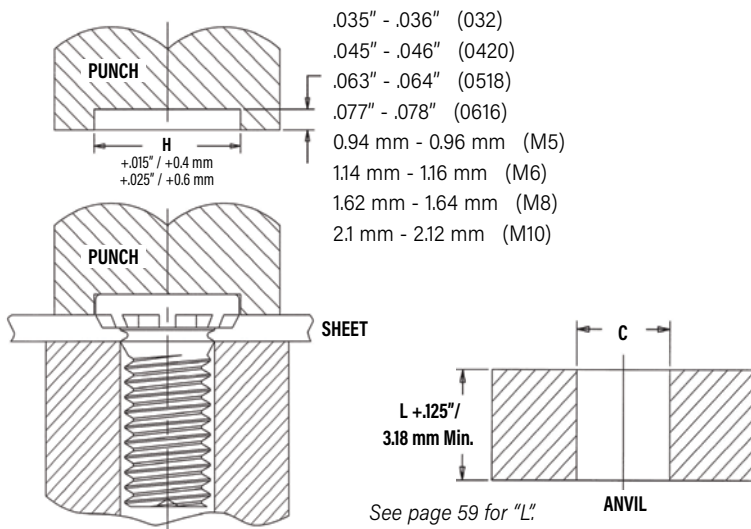

.035" - .036" (032)  
 .045" - .046" (0420)  
 .063" - .064" (0518)  
 .077" - .078" (0616)  
 0.94 mm - 0.96 mm (M5)  
 1.14 mm - 1.16 mm (M6)  
 1.62 mm - 1.64 mm (M8)  
 2.1 mm - 2.12 mm (M10)

See page 59 for "L"

### PEMSERTER® Installation Tooling

UNIFIED	Thread Code	Anvil Dimensions (in.)	Anvil Part Number	Punch Part Number
		C		
	032	.191 - .194	970200009300	970200311400
	0420	.250 - .253	970200010300	970200312400
	0518	.3125 - .3155	970200011300	970200313400
	0616	.375 - .378	970200004300	970200314400

METRIC	Thread Code	Anvil Dimensions (mm)	Anvil Part Number	Punch Part Number
		C + 0.08		
	M5	5.03	970200020300	970200311400
	M6	6.03	970200230300	970200312400
	M8	8.03	970200231300	970200313400
	M10	10.03	970200402300	970200491400

# SELF-CLINCHING STUDS AND PINS

## INSTALLATION - HFE™/THFE™/HFLH™ STUDS

### HFE™/HFLH™ STUDS

1. Prepare properly sized mounting hole in sheet. Do not perform any secondary operations such as deburring.
2. Insert stud through mounting hole (punch side) of sheet and into anvil hole.
3. With punch and anvil surfaces parallel, apply squeezing force on the punch sufficient only to embed the ribs on the head of the stud into the sheet.

Tooling for sheet thicknesses less than .060" / 1.51 mm with #10 / M5 and 1/4" / M6 thread sizes and less than .075" / 1.9 mm with 5/16" / M8 threads.

Tooling for sheet thicknesses .060" / 1.51 mm and greater with #10 / M5 and 1/4" / M6 thread sizes and .075" / 1.9 mm and greater with 5/16" / M8 threads.

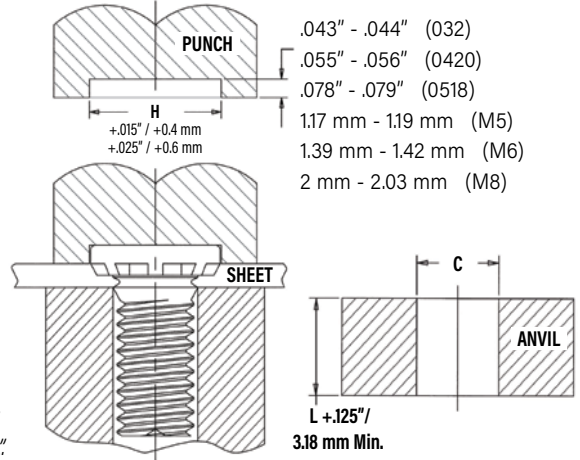
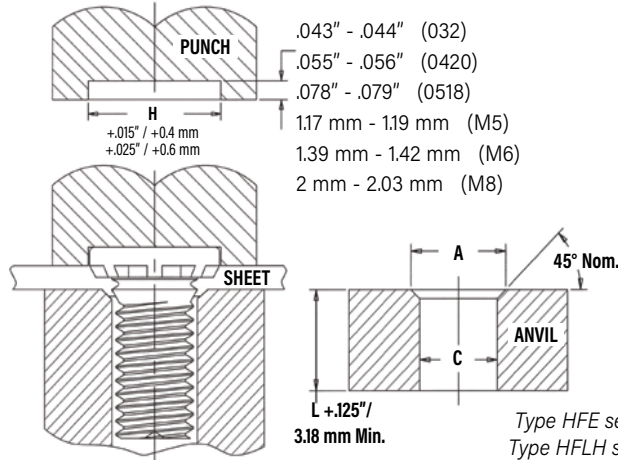

### PEMSERTER® Installation Tooling

UNIFIED	Thread Code	Anvil Dimensions (in.)		Anvil Part No. For Sheets > .060"	Anvil Part No. For Sheets .040" - .060"	Punch Part Number
		A	C			
	032	.216-.220	.191-.194	97020009300	970200246300	8003707
	0420	.295-.300	.250-.253	970200010300	8003702	8003708
				For Sheets > .075"	For Sheets .060" - .075"	
	0518	.334-.338	.3125-.3155	970200011300	8003703	8003709

METRIC	Thread Code	Anvil Dimensions (mm)		Anvil Part No. For Sheets > 1.51 mm	Anvil Part No. For Sheets 1 mm - 1.51 mm	Punch Part Number
		A + 0.1	C + 0.08			
	M5	5.6	5.03	970200020300	8003704	8003710
	M6	6.6	6.03	970200230300	8003705	8003711
				For Sheets > 1.9 mm	For Sheets 1.5 - 1.9 mm	
	M8	8.6	8.03	970200231300	8003706	8003712

### THFE™ STUDS

Tooling for sheet thicknesses less than .052" / 1.31 mm with 1/4" / M6 thread sizes, and less than .067" / 1.71 mm with 5/16" / M8 thread sizes.

Tooling for sheet thicknesses .052" / 1.31 mm and greater with 1/4" / M6 and .067" / 1.71 mm thread sizes and greater with 5/16" / M8 threads.

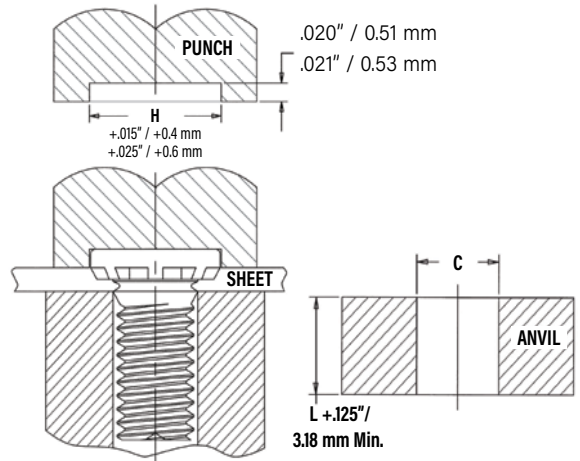
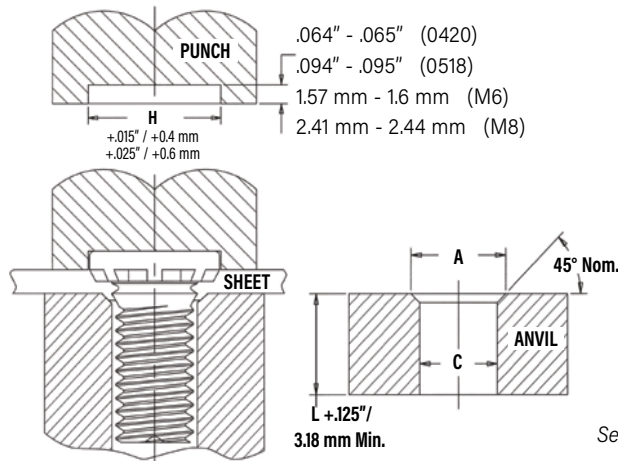

### PEMSERTER® Installation Tooling

UNIFIED	Thread Code	Anvil Dimensions (in.)		Anvil Part No. For Sheets > .051"	Anvil Part No. For Sheets .031" - .051"	Punch Part Number
		A	C			
	0420	.302-.306	.250-.253	970200010300	8019886	8019890
				For Sheets > .066"	For Sheets .031" - .066"	
	0518	.374-.378	.3125-.3155	970200011300	8019887	8019891

METRIC	Thread Code	Anvil Dimensions (mm)		Anvil Part No. For Sheets > 1.3 mm	Anvil Part No. For Sheets 0.8 - 1.3 mm	Punch Part Number
		A + 0.1	C + 0.08			
	M6	7.25	6.03	970200230300	8019888	8019892
				For Sheets > 1.7 mm	For Sheets 0.8 - 1.7 mm	
	M8	9.55	8.03	970200231300	8019889	8019893



Get quote

Angic Global Solutions

1-888-872-0690 [net.com](http://www.net.com) 71

<https://www.AngicGlobal.com> Sales@AngicGlobal.com

# SELF-CLINCHING STUDS AND PINS

## INSTALLATION - HFG8™/HF109™ STUDS

1. Prepare properly sized mounting hole in sheet. Do not perform any secondary operations such as deburring.
2. Insert stud through mounting hole (punch side) of sheet and into anvil hole.
3. With punch and anvil surfaces parallel, apply squeezing force on the punch sufficient only to embed the ribs on the head of the stud into the sheet. Note that for sheets .060" / 1.51 mm and thicker, the anvil requires only a straight thru hole to accommodate the stud. For sheets less than .060" / 1.51 mm to less than .075" / 1.9 mm, the hole requires a countersink with dimension A at the top to provide for metal flow around the shank of the stud.

Tooling for sheet thicknesses less than .060" / 1.51 mm with #10 / M5 and 1/4" / M6 thread sizes and less than .075" / 1.9 mm with 5/16" / M8 threads.

Tooling for sheet thicknesses .060" / 1.51 mm and greater with #10 / M5 and 1/4" / M6 thread sizes and .075" / 1.9 mm and greater with 5/16" / M8 threads.

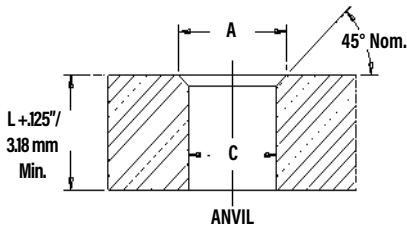
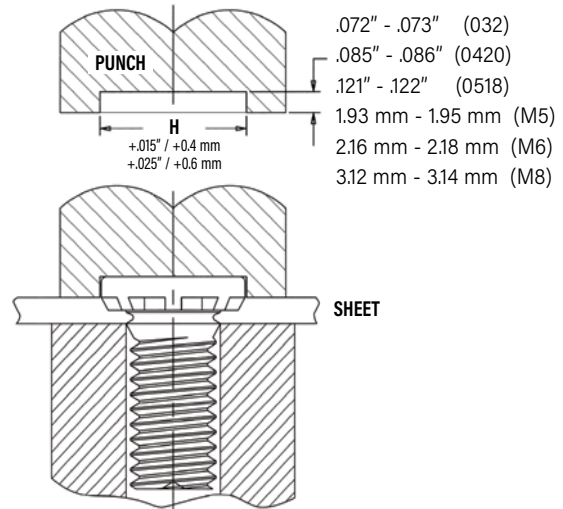
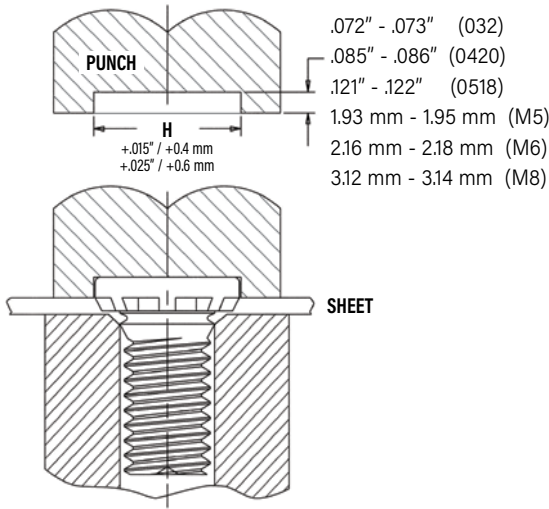

See page 61 for "L."

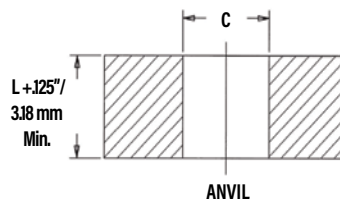

### PEMSERTER® Installation Tooling

UNIFIED	Thread Code	Anvil Dimensions (in.)		Anvil Part Number (Standard Sheet)	Anvil Part Number (Thin Sheet)	Punch Part Number
		A	C			
	032	.216 - .220	.191 - .194	970200009300	970200246300	8014456
	0420	.273 - .278	.250 - .253	8021609	8021613	8014458
	0518	.334 - .338	.3125 - .3155	8021610	8021614	8014460

METRIC	Thread Code	Anvil Dimensions (mm)		Anvil Part Number (Standard Sheet)	Anvil Part Number (Thin Sheet)	Punch Part Number
		A +0.1	C +0.08			
	M5	5.6	5.03	970200020300	8003704	8014457
	M6	6.6	6.03	8021611	8021615	8014459
	M8	8.6	8.03	8021612	8021616	8014461

# SELF-CLINCHING STUDS AND PINS

## INSTALLATION - SGPC™ SWAGING COLLAR STUDS

1. Prepare properly sized mounting hole in sheet.
2. Insert fastener through mounting hole (punch side) as shown in drawing.
3. With installation punch and anvil surfaces parallel, apply squeezing force until the punch pushes over the protruding knurls of the stud.

### PEMSERTER® Installation Tooling

UNIFIED	Thread Code	Punch Dimensions (in.)		Punch Part Number	Anvil Dimensions (in.)		Anvil Part Number
		A +.004 -.000	B +.000 -.001		C +.001	P +.000 -.002	
	256	.209	.019	8015111	.087	.014	8016983
440	.248	.022	8015112	.113	.014	8016984	
632	.276	.022	8015113	.139	.014	8016985	
832	.299	.022	8015114	.165	.014	8016986	
032	.327	.022	8015115	.191	.014	8016987	
0420	.386	.026	8015116	.251	.014	8016988	

METRIC	Thread Code	Punch Dimensions (mm)		Punch Part Number	Anvil Dimensions (mm)		Anvil Part Number
		A +.01	B -0.025		C +0.025	P -0.05	
	M2.5	5.5	0.47	8015117	2.53	0.35	8016989
M3	6.5	0.57	8015118	3.03	0.35	8016990	
M4	7.5	0.57	8015119	4.03	0.35	8016991	
M5	8.5	0.57	8015120	5.03	0.35	8016992	
M6	9.5	0.67	8015121	6.03	8016993		

NOTE: For panel design information, go to [http://www.pemnet.com/SGPC\\_Panel\\_Designs.pdf](http://www.pemnet.com/SGPC_Panel_Designs.pdf)

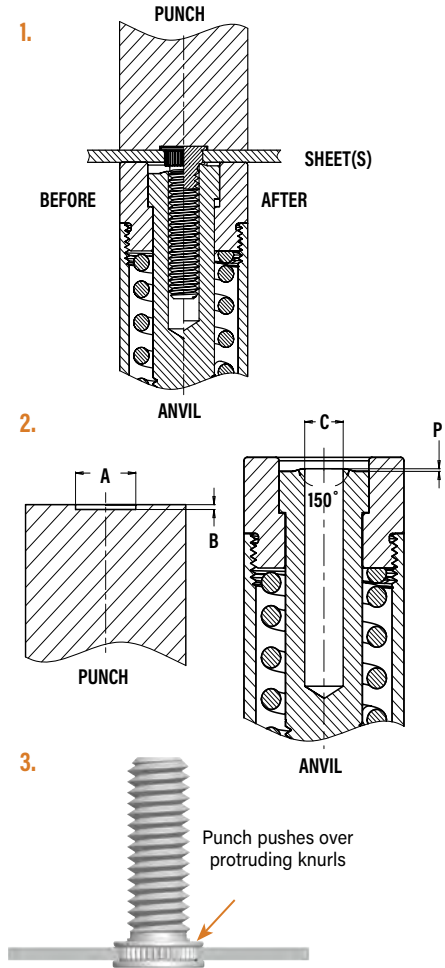

## INSTALLATION - FHX™ STUDS

1. Prepare properly sized mounting hole in sheet. Do not perform any secondary operations such as deburring.
2. Insert stud through mounting hole (punch side) of sheet and into anvil hole.
3. With punch and anvil surfaces parallel, apply squeezing force to embed the head of the stud flush in the sheet. In most cases, when using sheets 1.51 mm and thicker, the anvil requires only a straight thru hole to accommodate the stud (see illustrations below for details). For sheets less than 1.51 mm, the hole requires a countersink with dimension A at the top to provide for metal flow around the shank of the stud.

Tooling for sheet thicknesses less than 1.51 mm with 5 mm thread size and less than 2.4 mm for 6 mm thread size.

Tooling for sheet thicknesses 1.51 mm and greater with 5 mm thread size and 2.4 mm and greater for 6 mm thread size.

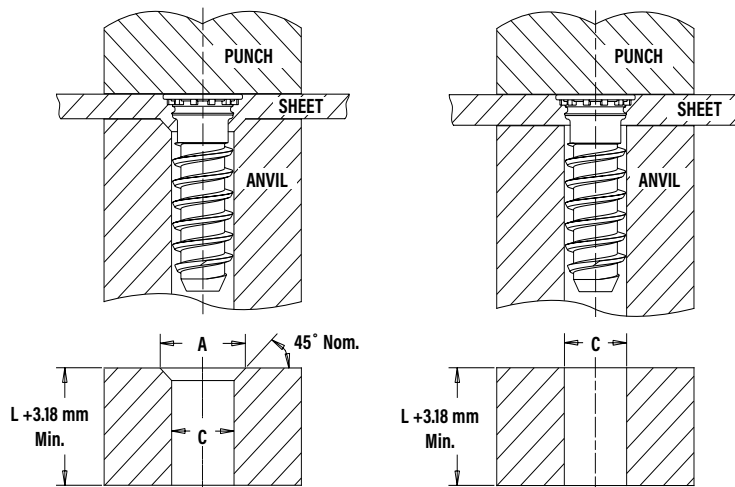

See page 64 for "L"

### PEMSERTER® Installation Tooling

Thread Code	Anvil Dimensions (mm)		Anvil Part No. For Sheets < 1.51	Anvil Part No. For Sheets ≥ 1.51	Punch Part Number
	A	C			
X5	6.12 - 6.22	5.23 - 5.31	8021189	8021188	975200048
				< 2.4	≥ 2.4
X6	7.04 - 7.14	6.25 - 6.33	8021191	8021190	975200048



Get quote >>

Angic Global Solutions

1-888-872-0690 [www.angic.com](http://www.angic.com) 73

<http://www.AngicGlobal.com> Sales@AngicGlobal.com

# SELF-CLINCHING STUDS AND PINS

## INSTALLATION - FH™/FHS™/FHA™ PINS

1. Prepare properly sized mounting hole in sheet. Do not perform any secondary operations such as deburring.
2. Insert pin through mounting hole (punch side) of sheet and into anvil hole.
3. With punch and anvil surfaces parallel, apply squeezing force to embed the head of the pin flush in the sheet. In most cases, when using sheets .060" / 1.51 mm and thicker, the anvil requires only a straight thru hole to accommodate the pin (see illustrations below for details). For sheets less than .060" / 1.51 mm, the hole requires a countersink with dimension A at the top to provide for metal flow around the shank of the pin.

Tooling for sheet thicknesses less than .060" / 1.52 mm with 073 thru 173 / 3 mm thru 5 mm pin diameter codes and for sheet thicknesses less than .093" / 2.36 mm with 207 thru 223 pin diameter codes.

Tooling for sheet thicknesses greater than .060" / 1.52 mm with 073 thru 173 / 3 mm thru 5 mm pin diameter codes and for sheet thicknesses greater than .093" / 2.36 mm with 207 thru 281 pin diameter codes.

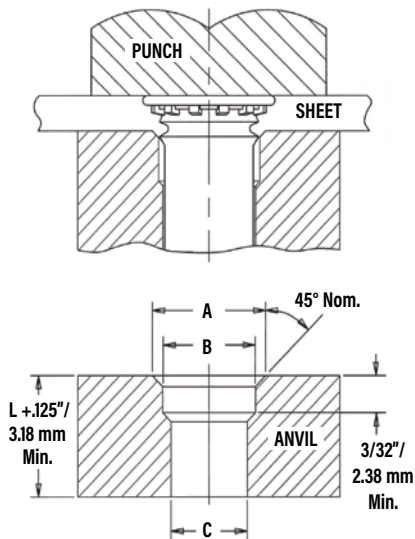

See page 65 for "L."

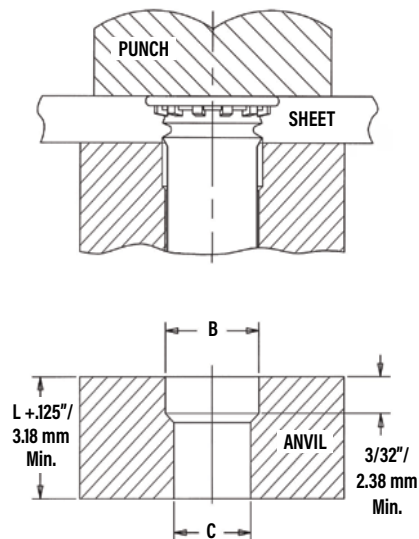

### PEMSERTER® Installation Tooling

UNIFIED	Pin Dia. Code	Anvil Dimensions (in.)		
		A +.004 -.000	B ±.002	C ±.002
	073	.116	.089	.078
	084	.133	.103	.089
	094	.162	.115	.099
	103	.166	.122	.109
	106	.168	.129	.111
	116	.191	.141	.121
	120	.191	.141	.125
	137	.215	.161	.144
	141	.216	.167	.147
	160	.244	.193	.166
	167	.244	.193	.172
	173	.250	.201	.180
	207	.286	.240	.213
	215	.290	.254	.221
	223	.298	.254	.228
	273	.325	.316	.277
	281	.320	.316	.290

METRIC	Pin Dia. Code	Anvil Dimensions (mm)		
		A +0.1	B ±0.05	C ±0.05
	3MM	4.9	3.61	3.1
	4MM	5.44	4.19	4.1
	5MM	6.93	5.61	5.1

# SELF-CLINCHING STUDS AND PINS

## INSTALLATION - TPS™/TP4™/TPXS™ PILOT PINS

1. Prepare properly sized mounting hole in sheet. Do not perform any secondary operations such as deburring.
2. Insert pin through mounting hole (punch side) of sheet and into anvil hole.
3. With punch and anvil surfaces parallel, apply squeezing force to embed the head of the pin flush in the sheet.

### PEMSERTER® Installation Tooling

UNIFIED	Pin Dia. Code	Test Sheet Thickness (in.)	Anvil Dimensions (in.)		Anvil Part Number	Punch Part Number
			A ±.002	C ±.002		
	125	.040 - .060 Over .060	.160 (1)	.130	8003284 8003278	975200048
187	.040 - .065 Over .065	.220 (1)	.192	8003285 8003279		
	250	.040 - .075 Over .075		.285 (1)	8003286 8003280	

METRIC	Pin Dia. Code	Test Sheet Thickness (mm)	Anvil Dimensions (mm)		Anvil Part Number	Punch Part Number
			A ±0.05	C ±0.05		
	3MM	1 - 1.7	3.88	3.11	8008096	975200048
Over 1.7		(1)	8008095			
4MM	1 - 1.7	4.88	4.11	8003287		
	Over 1.7	(1)		8003281		
5MM	1 - 1.8	5.89	5.13	8003288		
	Over 1.8	(1)		8003282		
6MM	1 - 1.9	6.89	6.12	8003289		
	Over 1.9	(1)		8003283		

(1) Chamfered anvil not required.

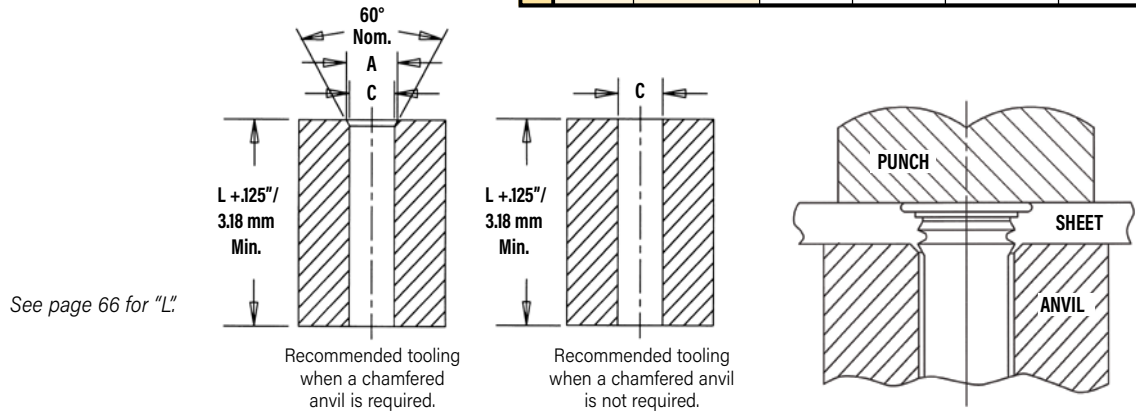

### INSTALLATION NOTES

- For best results we recommend using a Haeger® or PEMSERTER® machine for installation of PEM® self-clinching fasteners. Please check our website for more information.
- Visit the Animation Library on our website to view the installation process [for select products](#).



Get quote »

Angic Global Solutions

1-888-872-0690 [met.com](#) 75

<https://www.AngicGlobal.com> Sales@AngicGlobal.com

# SELF-CLINCHING STUDS AND PINS

Published installation forces are for general reference. Actual set-up and confirmation of complete installation should be made by observing proper seating of fastener as described in the installation steps. Other performance values reported are averages when all proper installation parameters and procedures are followed. Variations in mounting hole size, sheet material, and installation procedure may affect performance. Performance testing this product in your application is recommended. We will be happy to provide technical assistance and/or samples for this purpose.

## PERFORMANCE DATA - FH™/FHS™ FLUSH-HEAD STUDS

UNIFIED	Thread Code	Rec. Nut Tightening Torque (in. lbs.) (1)	Type	Test Sheet Thickness & Material	Sheet Hardness HRB	Installation (lbs.)	Pushout (lbs.)	Torque-out (in. lbs.)	Pull Thru (lbs.)
	256	4.4	FH	.062" Aluminum	29	2000	100	5	425
		2.7	FHS	.062" Aluminum	29	2000	100	4.5	300
	440	4.4	FH	.060" Steel	59	2500	180	5	425
		2.7	FHS	.060" Steel	59	2500	180	4.5	300
	632	8.7	FH	.064" Aluminum	29	3800	170	10	650
		5.9	FHS	.064" Aluminum	29	3200	170	8	500
		8.7	FH	.060" Steel	59	4300	275	10	650
	832	5.9	FHS	.060" Steel	59	4700	275	8	500
		14	FH	.064" Aluminum	29	3800	180	17	850
11		FHS	.064" Aluminum	29	3500	180	16	775	
032/024	14	FH	.060" Steel	59	4700	300	20	850	
	11	FHS	.060" Steel	59	5000	300	16	775	
	20	FH	.064" Aluminum	29	4800	220	28	1000	
0420	16	FHS	.064" Aluminum	29	4500	220	28	940	
	25	FH	.060" Steel	59	6800	375	40	1270	
	19	FHS	.060" Steel	59	5500	375	28	1130	
0518	28	FH	.064" Aluminum	29	5500	270	30	1220	
	24	FHS	.064" Aluminum	29	5500	270	30	1220	
	32	FH	.060" Steel	59	7500	450	60	1410	
0420	28	FHS	.060" Steel	59	6800	450	50	1410	
	69	FH	.093" Aluminum	28	6500	310	65	2300	
	55	FHS	.093" Aluminum	28	6500	310	65	2100	
0518	77	FH	.088" Steel	46	9500	575	100	2550	
	67	FHS	.088" Steel	46	10000	575	100	2550	
	85	FH	.093" Aluminum	28	6500	430	100	2260	
0518	74	FHS	.093" Aluminum	28	6700	430	100	2260	
	130	FH	.093" Steel	46	10000	650	175	3475	
	102	FHS	.093" Steel	46	11200	650	175	3120	

METRIC	Thread Code	Rec. Nut Tightening Torque (N-m) (1)	Type	Test Sheet Thickness & Material	Sheet Hardness HRB	Installation (kN)	Pushout (N)	Torque-out (N-m)	Pull Thru (N)
	M2.5	0.78	FH	1.6 mm Aluminum	29	8.9	465	1.0	2600
		0.48	FHS	1.6 mm Aluminum	29	11.6	465	0.8	1820
		0.84	FH	1.5 mm Steel	59	11.1	740	1.0	2800
		0.48	FHS	1.5 mm Steel	59	13.8	740	0.8	1820
	M3	1.1	FH	1.6 mm Aluminum	29	12.9	600	1.7	3150
		0.81	FHS	1.6 mm Aluminum	29	12.9	600	1.3	2570
		1.4	FH	1.5 mm Steel	59	14.7	820	1.7	3840
		0.77	FHS	1.5 mm Steel	59	14.7	820	1.3	2440
	M3.5	1.6	FH	1.6 mm Aluminum	29	15.6	800	1.7	3780
1.3		FHS	1.6 mm Aluminum	29	15.6	800	1.7	3445	
1.6		FH	1.5 mm Steel	59	22.3	1335	2.8	3780	
1.3		FHS	1.5 mm Steel	59	22.3	1335	2.0	3445	
M4	2.1	FH	1.6 mm Aluminum	29	20	975	2.9	4448	
	1.8	FHS	1.6 mm Aluminum	29	22.3	975	2.9	4180	
	2.7	FH	1.5 mm Steel	59	28.9	1780	4.2	5650	
	2	FHS	1.5 mm Steel	59	26.7	1780	2.9	4775	
M5	3.1	FH	1.6 mm Aluminum	29	24.5	1070	3.5	5170	
	2.5	FHS	1.6 mm Aluminum	29	24.5	1070	3.5	4760	
	3.8	FH	1.5 mm Steel	59	33.4	2000	6.5	6270	
	3.2	FHS	1.5 mm Steel	59	32.5	2000	6.3	6000	
M6	7.3	FH	2.4 mm Aluminum	28	28.9	1660	7.3	10200	
	5.7	FHS	2.4 mm Aluminum	28	28.9	1660	7.3	9090	
	8.1	FH	2.2 mm Steel	46	44.5	2560	11.3	11300	
	6.7	FHS	2.2 mm Steel	46	44.5	2560	10.1	10600	
M8	10	FH	2.4 mm Aluminum	28	29.8	1910	11.3	10500	
	8	FHS	2.4 mm Aluminum	28	29.8	1910	11.3	9540	
	15	FH	2.4 mm Steel	46	44.5	2890	19.2	15450	
	11	FHS	2.4 mm Steel	46	49.8	2890	17.5	13630	

(1) Tightening torque shown is a theoretical value calculated to induce a load of 75% of minimum axial yield strength of the stud with an assumed K value or nut factor equal to 0.20. In some applications tightening torque may need to be adjusted based on the actual K value.



# SELF-CLINCHING STUDS AND PINS

## PERFORMANCE DATA - FHA™ FLUSH-HEAD STUDS

UNIFIED	Thread Code	Rec. Nut Tightening Torque (in. lbs.) <sup>(1)</sup>	Type	Test Sheet Thickness & Material	Sheet Hardness HRI5T	Installation (lbs.)	Pushout (lbs.)	Torque-out (in. lbs.)	Pull Thru (lbs.)
	440	3.6	FHA	.061" 5052-H34 Aluminum	75	2500	155	4	270
	632	6.3	FHA	.061" 5052-H34 Aluminum	75	2600	180	8	380
	832	9.8	FHA	.061" 5052-H34 Aluminum	73	3200	190	15	500
	032	14	FHA	.061" 5052-H34 Aluminum	75	3200	220	28	600
	0420	32	FHA	.062" 5052-H34 Aluminum	75	5500	300	55	1050

METRIC	Thread Code	Rec. Nut Tightening Torque (N-m) <sup>(1)</sup>	Type	Test Sheet Thickness & Material	Sheet Hardness HRI5T	Installation (kN)	Pushout (N)	Torque-out (N-m)	Pull Thru (N)
	M3	0.54	FHA	1.55 mm 5052-H34 Aluminum	74	10.7	575	0.5	1500
	M4	0.96	FHA	1.55 mm 5052-H34 Aluminum	75	14.3	775	1.35	2000
	M5	1.5	FHA	1.55 mm 5052-H34 Aluminum	75	15.2	900	2.6	2500
	M6	3.2	FHA	1.6 mm 5052-H34 Aluminum	75	24.5	1500	5.3	4500

## PERFORMANCE DATA - FH4™ STUDS<sup>(2)</sup>

UNIFIED	Thread Code	Rec. Nut Tightening Torque (in. lbs.) <sup>(1)</sup>	Test Sheet Thickness and Material <sup>(3)</sup>	Sheet Hardness HRB	Installation (lbs.)	Pushout (lbs.)	Torque-out (in. lbs.)	Pull Thru (lbs.)
	440	11	.060" Stainless Steel	87	9000	450	16	800
	632	22	.060" Stainless Steel	87	9500	540	27	1350
	832	35	.060" Stainless Steel	86	11200	780	58	1800
	032	51	.060" Stainless Steel	86	12000	800	95	2250
	0420	117	.062" Stainless Steel	88	23000	1600	156	3900

METRIC	Thread Code	Rec. Nut Tightening Torque (N-m) <sup>(1)</sup>	Test Sheet Thickness and Material <sup>(3)</sup>	Sheet Hardness HRB	Installation (kN)	Pushout (N)	Torque-out (N-m)	Pull Thru (N)
	M3	1.3	1.5 mm Stainless Steel	87	40	2220	1.8	3500
	M4	3.8	1.5 mm Stainless Steel	86	50	3210	6.5	8000
	M5	6	1.5 mm Stainless Steel	86	53	3560	10.7	10000
	M6	11	1.6 mm Stainless Steel	88	100	4200	15.9	14900

## PERFORMANCE DATA - FHP™ STUDS<sup>(2)</sup>

UNIFIED	Thread Code	Rec. Nut Tightening Torque (in. lbs.) <sup>(1)</sup>	Test Sheet Thickness and Material <sup>(3)</sup>	Sheet Hardness HRB	Installation (lbs.)	Pushout (lbs.)	Torque-out (in. lbs.)	Pull Thru (lbs.)
	440	8.1	.045" Stainless Steel	86	9000	520	10.6	605
	632	16	.045" Stainless Steel	86	9500	670	19.5	940
	832	28	.045" Stainless Steel	86	11200	785	37.5	1415
	032	34	.045" Stainless Steel	86	12000	800	59.5	1500

METRIC	Thread Code	Rec. Nut Tightening Torque (N-m) <sup>(1)</sup>	Test Sheet Thickness and Material <sup>(3)</sup>	Sheet Hardness HRB	Installation (kN)	Pushout (N)	Torque-out (N-m)	Pull Thru (N)
	M3	1.3	2 mm Stainless Steel	86	40	2500	1.6	3500
	M4	2.9	1.14 mm Stainless Steel	86	50	3000	3.9	6000
	M5	4.4	1.14 mm Stainless Steel	86	53	3560	7.35	7320

- (1) Tightening torque shown is a theoretical value calculated to induce a load of 75% of minimum axial yield strength of the stud with an assumed K value or nut factor equal to 0.20. In some applications tightening torque may need to be adjusted based on the actual K value.
- (2) Performance values shown are typical for fasteners properly installed using raised ring tooling in good condition. We recommend replacing installation tooling when the height of the "P" falls out of tolerance (see page 71). Reductions in performance may occur as the height of the protrusion wears. Variations in hole preparation, installation force, and sheet material type, thickness, and hardness will affect both performance and tooling life.
- (3) Performance may be reduced for studs installed into thicker sheets.



# SELF-CLINCHING STUDS AND PINS

## PERFORMANCE DATA - FHL™/FHLS™ STUDS

UNIFIED	Thread Code	Rec. Nut Tightening Torque (in. lbs.) <sup>(1)</sup>	Type	Test Sheet Thickness and Material	Sheet Hardness HRB	Installation (lbs.)	Pushout (lbs.)	Torque-out (in. lbs.)	Pull Thru (lbs.)	Pull Thru Test Bushing Hole Size (in.)
	256	2.1	FHL / FHLS	.047" Aluminum	33	700	55	4	230	.106
3.8		FHL / FHLS	.045" Steel	54	1200	85	8	425	.106	
440	3.5	FHL / FHLS	.047" Aluminum	33	1000	60	5	300	.132	
	6.8	FHL / FHLS	.045" Steel	54	1200	105	11	580	.132	
632	4.7	FHL / FHLS	.047" Aluminum	33	1000	65	6.5	325	.158	
	9	FHL / FHLS	.045" Steel	54	1500	110	15	650	.158	
832	6	FHL / FHLS	.047" Aluminum	33	1200	80	9	350	.184	
	13	FHL / FHLS	.045" Steel	54	1500	125	18	740	.184	
032	7.9	FHL / FHLS	.047" Aluminum	33	2500	115	18	395	.210	
	16	FHL / FHLS	.045" Steel	54	4500	210	38	800	.210	

METRIC	Thread Code	Rec. Nut Tightening Torque (N-m) <sup>(1)</sup>	Type	Test Sheet Thickness and Material	Sheet Hardness HRB	Installation (kN)	Pushout (N)	Torque-out (N-m)	Pull Thru (N)	Pull Thru Test Bushing Hole Size (mm)
	M2.5	0.32	FHL / FHLS	1.2 mm Aluminum	33	3.1	285	0.55	1200	3
0.59		FHL / FHLS	1.1 mm Steel	54	5.3	450	1.1	2250	3	
M3	0.41	FHL / FHLS	1.2 mm Aluminum	33	4.4	285	0.65	1300	3.5	
	0.79	FHL / FHLS	1.1 mm Steel	54	5.3	475	1.25	2500	3.5	
M3.5	0.51	FHL / FHLS	1.2 mm Aluminum	33	4.4	290	0.76	1400	4	
	1.03	FHL / FHLS	1.1 mm Steel	54	6.6	500	1.75	2800	4	
M4	0.65	FHL / FHLS	1.2 mm Aluminum	33	5.3	365	1.1	1550	4.5	
	1.39	FHL / FHLS	1.1 mm Steel	54	6.6	550	2.1	3300	4.5	
M5	0.97	FHL / FHLS	1.2 mm Aluminum	33	11.1	530	2.2	1850	5.5	
	1.97	FHL / FHLS	1.1 mm Steel	54	20	1000	4.4	3750	5.5	

## PERFORMANCE DATA - TFH™/TFHS™ NON-FLUSH STUDS

UNIFIED	Thread Code	Rec. Nut Tightening Torque (in. lbs.) <sup>(1)</sup>	Type	Test Sheet Thickness and Material	Sheet Hardness HRB	Installation (lbs.) <sup>(2)</sup>	Pushout (lbs.)	Torque-out (in. lbs.)	Pull Thru (lbs.)	Pull Thru Test Bushing Hole Size (in.)
	440	9.2	TFH	.025" Aluminum	38	1300	75	10	683	.132
6.2		TFHS	.025" Aluminum	38	1200	75	8	527	.132	
9.2		TFH	.022" Steel	57	2800	85	10	684	.132	
6.2		TFHS	.022" Steel	57	1500	80	9	531	.132	
632	13	TFH	.025" Aluminum	41	2400	87	9	791	.158	
	11	TFHS	.025" Aluminum	41	2400	88	12	748	.158	
	15	TFH	.022" Steel	57	2800	97	14	906	.158	
	11	TFHS	.022" Steel	57	2800	100	16	750	.158	
832	19	TFH	.025" Aluminum	41	2100	94	14	943	.184	
	17	TFHS	.025" Aluminum	41	2200	94	17	963	.184	
	21	TFH	.022" Steel	57	3500	111	23	1065	.184	
	19	TFHS	.022" Steel	57	2700	113	26	1109	.184	
024/032	24	TFH	.025" Aluminum	38	2300	98	13	1033	.210	
	21	TFHS	.025" Aluminum	38	2500	101	12	1040	.210	
	28	TFH	.022" Steel	57	3900	121	25	1214	.210	
	24	TFHS	.022" Steel	57	3200	112	23	1184	.210	

METRIC	Thread Code	Rec. Nut Tightening Torque (N-m) <sup>(1)</sup>	Type	Test Sheet Thickness and Material	Sheet Hardness HRB	Installation (kN) <sup>(2)</sup>	Pushout (N)	Torque-out (N-m)	Pull Thru (N)	Pull Thru Test Bushing Hole Size (mm)
	M3	1.1	TFH	0.65 mm Aluminum	42	5.8	370	0.72	3091	3.51
0.93		TFHS	0.65 mm Aluminum	43	5.8	255	0.19	2962	3.51	
1.3		TFH	0.57 mm Steel	57	8	419	1.32	3477	3.51	
0.94		TFHS	0.57 mm Steel	57	6.7	394	0.84	2971	3.51	
M4	1.9	TFH	0.65 mm Aluminum	42	14.2	396	1.29	3963	4.5	
	1.7	TFHS	0.65 mm Aluminum	40	9.8	391	1.83	4126	4.5	
	2.1	TFH	0.57 mm Steel	57	17.8	453	1.69	4380	4.5	
	2	TFHS	0.57 mm Steel	57	13.4	460	2.49	4701	4.5	
M5	2.8	TFH	0.64 mm Aluminum	42	3.2	499	1.71	4720	5.51	
	2.6	TFHS	0.64 mm Aluminum	42	3.2	518	2.29	4977	5.51	
	3.4	TFH	0.56 mm Steel	57	12.1	570	2.77	5654	5.51	
	2.8	TFHS	0.57 mm Steel	57	12.9	582	2.9	5328	5.51	

(1) Tightening torque shown is a theoretical value calculated to induce a load of 75% of minimum axial yield strength of the stud with an assumed K value or nut factor equal to 0.20. In some applications tightening torque may need to be adjusted based on the actual K value.  
 (2) Installation controlled by proper cavity depth in punch.

# SELF-CLINCHING STUDS AND PINS

## PERFORMANCE DATA - HFE™ STUDS

UNIFIED	Thread Code	Rec. Nut Tightening Torque (ft. lbs.) <sup>(1)</sup>	Test Sheet Thickness and Material <sup>(2)</sup> (in.)	Sheet Hardness HRB	Installation (lbs.) <sup>(3)</sup>	Pushout (lbs.)	Torque-out (in. lbs.)	Tensile Strength (lbs.) <sup>(4)</sup>	Pull Thru (lbs.)	Test Bushing Hole Size For Pull Thru Tests
	032	3.6	.040" Aluminum	27	7500	170	60	2400	1900	.279
4.2		.040" Cold-rolled Steel	67	9500	300	60	2400	2200		
0420	8	.040" Aluminum	27	8000	180	120	3820	3200	.335	
	9	.040" Cold-rolled Steel	67	13500	340	130	3820	3600		
0518	19	.060" Aluminum	22	9000	275	240	6280	6000	.407	
	20	.060" Cold-rolled Steel	65	15500	575	290	6280	6280		

METRIC	Thread Code	Rec. Nut Tightening Torque (N-m) <sup>(1)</sup>	Test Sheet Thickness and Material <sup>(2)</sup> (mm)	Sheet Hardness HRB	Installation (kN) <sup>(3)</sup>	Pushout (N)	Torque-out (N-m)	Tensile Strength (kN) <sup>(4)</sup>	Pull Thru (kN)	Test Bushing Hole Size For Pull Thru Tests
	M5	5.8	1 mm Aluminum	27	377	690	8.1	12.8	9.7	7.4
6.4		1 mm Cold-rolled Steel	67	51.1	1350	8.1	12.8	10.6		
M6	10	1 mm Aluminum	27	39	750	11.8	18.1	14.2	8.2	
	11	1 mm Cold-rolled Steel	67	60	1400	14.4	18.1	15.5		
M8	24	1.5 mm Aluminum	22	42	1230	23.5	32.9	25	10.3	
	26	1.5 mm Cold-rolled Steel	65	71.1	2400	33.9	32.9	27.5		

## PERFORMANCE DATA - THFE™ STUDS

UNIFIED	Thread Code	Rec. Nut Tightening Torque (ft. lbs.) <sup>(1)</sup>	Test Sheet Thickness and Material <sup>(2)</sup> (in.)	Sheet Hardness HRB	Installation (lbs.) <sup>(3)</sup>	Pushout (lbs.)	Torque-out (in. lbs.)	Tensile Strength (lbs.) <sup>(4)</sup>	Pull Thru (lbs.)	Test Bushing Hole Size For Pull Thru Tests
	0420	8.1	.031" Aluminum	35	8800	116	71	3820	3249	.340
8.5		.031" Cold-rolled Steel	47	13500	197	116	3820	3388		
0518	18	.031" Aluminum	44	11700	131	103	6280	5701	.402	
	18	.031" Cold-rolled Steel	47	16000	187	124	6280	5772		

METRIC	Thread Code	Rec. Nut Tightening Torque (N-m) <sup>(1)</sup>	Test Sheet Thickness and Material <sup>(2)</sup> (mm)	Sheet Hardness HRB	Installation (kN) <sup>(3)</sup>	Pushout (N)	Torque-out (N-m)	Tensile Strength (kN) <sup>(4)</sup>	Pull Thru (kN)	Test Bushing Hole Size For Pull Thru Tests
	M6	9	0.8 mm Aluminum	38	39.2	550	7.3	18.1	13	8.3
10		0.8 mm Cold-rolled Steel	47	60.1	886	13.4	18.1	14.3		
M8	27	0.8 mm Aluminum	44	56	582	12.2	32.9	27.8	10.3	
	27	0.8 mm Cold-rolled Steel	47	71.2	881	13.1	32.9	28.1		

- (1) Tightening torque shown is a theoretical value calculated to induce a load of 75% of minimum axial yield strength of the stud with an assumed K value or nut factor equal to 0.20. In some applications tightening torque may need to be adjusted based on the actual K value.
- (2) See [tech sheet](#) on our website for performance data of PEM® Types HFE™ and THFE™ studs installed into copper sheets.
- (3) Installation controlled by proper cavity depth in punch.
- (4) Head size is adequate to ensure failure in threaded area when tested with industry standard tensile bushing diameter.



Get quote >>

Angic Global Solutions

1-888-872-0690 [let.com](#) 79

<https://www.AngicGlobal.com> Sales@AngicGlobal.com

# SELF-CLINCHING STUDS AND PINS

## PERFORMANCE DATA - HFH™/HFHS™/HFHB™ STUDS

UNIFIED	Thread Code	Type	Rec. Nut Tightening Torque (ft. lbs.) <sup>(1)</sup>	Test Sheet Thickness and Material	Sheet Hardness HRB	Installation (lbs.) <sup>(2)</sup>	Pushout (lbs.)	Torque-out (ft. lbs.)	Tensile Strength (lbs.)
	032	HFH	4.6	.060" Aluminum	15	3000	180	4	2400
		HFH	4.6	.060" Steel	65	6000	375	5	2400
		HFHS	2.5	.050" Aluminum	38	3000	180	4	1500
		HFHS	2.5	.058" Steel	52	4500	325	4	1500
		HFHB	1.7	.061" Copper CDA-110	28	3400	150	2.9	1200
	0420	HFH	9.6	.060" Aluminum	43	5500	285	11	3820
		HFH	9.6	.060" Steel	59	7000	480	11	3820
		HFHS	5.2	.064" Aluminum	32	4000	285	8	2385
		HFHS	5.2	.072" Steel	43	6500	480	8	2385
HFHB		3.6	.061" Copper CDA-110	28	6000	380	5	1908	
0518	HFH	20	.091" Aluminum	39	8000	380	22	6280	
	HFH	20	.090" Steel	58	10000	590	22	6280	
	HFHS	11	.087" Aluminum	41	5500	380	15	3930	
	HFHS	11	.099" Steel	44	7500	590	15	3930	
	HFHB	7	.126" Copper CDA-110	32	7500	500	11	3140	
0616	HFH	35	.091" Aluminum	39	12000	550	25	9300	
	HFH	35	.090" Steel	58	16000	780	36	9300	
	HFHS	19	.123" Aluminum	44	10000	560	25	5810	
	HFHS	19	.099" Steel	44	13000	780	25	5810	
	HFHB	13	.126" Copper CDA-110	32	12000	560	18	4650	

METRIC	Thread Code	Type	Rec. Nut Tightening Torque (N-m) <sup>(1)</sup>	Test Sheet Thickness and Material	Sheet Hardness HRB	Installation (kN) <sup>(2)</sup>	Pushout (N)	Torque-out (N-m)	Tensile Strength (kN)
	M5	HFH	7.7	1.5 mm Aluminum	15	13	800	5.4	12.8
		HFH	7.7	1.5 mm Steel	65	26	1500	7.6	12.8
		HFHS	3.8	1.62 mm Aluminum	35	12.4	800	5.4	7.3
		HFHS	3.8	1.47 mm Steel	54	21.7	1500	6.4	7.3
		HFHB	2.7	1.5 mm Copper CDA-110	28	15.6	1115	3.4	5.9
	M6	HFH	13	1.5 mm Aluminum	43	29	1270	14	18.1
		HFH	13	1.5 mm Steel	59	33	1750	14	18.1
		HFHS	6.5	1.62 mm Aluminum	35	15.4	1270	11	10.3
		HFHS	6.5	1.6 mm Steel	45	24.6	1750	11	10.3
HFHB		4.5	1.5 mm Copper CDA-110	28	25.3	1600	6.7	8.3	
M8	HFH	32	2.3 mm Aluminum	39	36.6	1700	30	32.9	
	HFH	32	2.3 mm Steel	58	44.5	2200	30	32.9	
	HFHS	16	2.23 mm Aluminum	44	24.4	1700	20	18.8	
	HFHS	16	2.48 mm Steel	43	37.8	2100	20	18.8	
	HFHB	11	3.2 mm Copper CDA-110	32	33	2250	15.3	15.1	
M10	HFH	63	2.3 mm Aluminum	39	53.3	2445	36	52.2	
	HFH	63	2.3 mm Steel	58	71.2	3470	49	52.2	
	HFHS	31	2.3 mm Aluminum	44	44.4	2445	36	29.9	
	HFHS	31	2.3 mm Steel	44	57.7	3470	36	29.9	
	HFHB	22	3.2 mm Copper CDA-110	32	53.3	2500	25	24	

## PERFORMANCE DATA - HFG8™/HF109™ HIGH TENSILE STRENGTH STUDS

UNIFIED	Thread Code	Rec. Nut Tightening Torque (ft. lbs.)	Tensile Strength (lbs.) <sup>(3)</sup>	Test Sheet Material	Sheet Hardness HRB	Installation (lbs.) <sup>(2)</sup>	Pushout (lbs.)	Torque-out (ft. lbs.)	Test Sheet Material	Sheet Hardness HRB	Installation (lbs.) <sup>(2)</sup>	Pushout (lbs.)	Torque-out (ft. lbs.)
	032	6.4	3000	.047" HSLA Steel	85.5	14000	483	6.2	.040" Cold-rolled Steel	45.0	9900	249	5.9
	0420	13	4750	.047" HSLA Steel	85.7	21400	592	11.5	.040" Cold-rolled Steel	45.0	14100	248	11.5
	0518	28	7850	.060" HSLA Steel	84.9	32600	667	25.6	.060" Cold-rolled Steel	55.2	19100	447	25.2

METRIC	Thread Code	Rec. Nut Tightening Torque (N-m)	Tensile Strength (kN) <sup>(3)</sup>	Test Sheet Material	Sheet Hardness HRB	Installation (kN) <sup>(2)</sup>	Pushout (N)	Torque-out (N-m)	Test Sheet Material	Sheet Hardness HRB	Installation (kN) <sup>(2)</sup>	Pushout (N)	Torque-out (N-m)
	M5	10	14.8	1.2 mm HSLA Steel	86.1	60.1	2084	9	1 mm Cold-rolled Steel	45.3	43.2	978	9
	M6	17	20.9	1.2 mm HSLA Steel	85.6	90	2454	15.6	1 mm Cold-rolled Steel	45.5	60	1072	14.4
	M8	41	38.1	1.5 mm HSLA Steel	84	145	3026	38.4	1.5 mm Cold-rolled Steel	55	85	1992	37.7

- (1) Tightening torque shown is a theoretical value calculated to induce a load of 75% of minimum axial yield strength of the stud with an assumed K value or nut factor equal to 0.20. In some applications tightening torque may need to be adjusted based on the actual K value.
- (2) Installation controlled by proper cavity depth in punch.
- (3) Head size is adequate to ensure failure in threaded area when tested with industry standard tensile bushing diameter.

# SELF-CLINCHING STUDS AND PINS

## PERFORMANCE DATA - HFLH™ STUDS

UNIFIED	Thread Code	Rec. Nut Tightening Torque (ft. lbs.) <sup>(1)</sup>	Test Sheet Thickness and Material (in.)	Sheet Hardness HRB	Installation (lbs.) <sup>(2)</sup>	Pushout (lbs.)	Torque-out (in. lbs.)	Tensile Strength (lbs.) <sup>(3)</sup>	Pull Thru (lbs.)	Test Bushing Hole Size For Pull Thru Tests
	032	4.2	.040" HC500LA	89	9500	300	60	2400	2200	.279
	0420	10	.040" HC500LA	89	13500	340	130	3820	3600	.335
	0518	23	.060" HC500LA	91	16000	575	290	6280	6280	.407

METRIC	Thread Code	Rec. Nut Tightening Torque (N-m) <sup>(1)</sup>	Test Sheet Thickness and Material (mm)	Sheet Hardness HRB	Installation (kN) <sup>(2)</sup>	Pushout (N)	Torque-out (N-m)	Tensile Strength (kN) <sup>(3)</sup>	Pull Thru (kN)	Test Bushing Hole Size For Pull Thru Tests
	M5	6.4	1 mm HC500LA	89	51.1	1350	8.1	12.8	10.6	7.4
	M6	11	1 mm HC500LA	89	60	1400	14.4	18.1	15.5	8.2
	M8	26	1.5 mm HC500LA	91	71.1	2400	33.9	32.9	27.5	10.3

## PERFORMANCE DATA - SGPC™ SWAGING COLLAR STUDS

UNIFIED	Thread Code	Rec. Nut Tightening Torque (in. lbs.) <sup>(1)</sup>	Test Sheet Material			
			Single sheet of .039" 300 Series Stainless Steel			
			Installation (lbs.)	Pushout (lbs.)	Torque-out (in. lbs.)	Pull-thru (lbs.)
	256	3.7	4000	425	5.2	415
440	6	5000	450	8	512	
632	12	5500	460	15.8	811	
832	20	6500	480	29.3	1133	
032	25	7300	545	42.8	1273	
0420	45	10000	565	76.7	1721	

METRIC	Thread Code	Rec. Nut Tightening Torque (N-m) <sup>(1)</sup>	Test Sheet Material			
			Single sheet of 1 mm 300 Series Stainless Steel			
			Installation (kN)	Pushout (N)	Torque-out (N-m)	Pull-thru (N)
	M2.5	0.67	20.1	2546	0.86	2561
M3	0.9	21.8	2051	1.35	2851	
M4	2.5	28.5	2396	2.66	4000	
M5	3.3	35.6	3200	5.96	4284	
M6	3.3	42.3	3262	9.19	6311	

## PERFORMANCE DATA - FHX™ STUDS WITH X-PRESS™ THREAD PROFILE

Thread Code	Test Sheet Material (4)	Installation kN	Pushout N	Torque-out N-m
X5	1.1 mm Steel HRB 58 / HB 104	24.9	1519	4.7
	1.2 mm Aluminum HRB 44 / HB 66	19.2	1070	3.2
X6	1.6 mm Steel HRB 58 / HB 104	35.6	2964	13.3
	1.6 mm Aluminum HRB 44 / HB 66	29.4	1623	7

- (1) Tightening torque shown is a theoretical value calculated to induce a load of 75% of minimum axial yield strength of the stud with an assumed K value or nut factor equal to 0.20. In some applications tightening torque may need to be adjusted based on the actual K value.
- (2) Installation controlled by proper cavity depth in punch.
- (3) Head size is adequate to ensure failure in threaded area when tested with industry standard tensile bushing diameter.
- (4) HRB - Hardness Rockwell "B" Scale. HB - Hardness Brinell.



Get quote >>

Angic Global Solutions

1-888-872-0690 [www.AngicGlobal.com](https://www.AngicGlobal.com) 81

<https://www.AngicGlobal.com> Sales@AngicGlobal.com

# SELF-CLINCHING STUDS AND PINS

## PERFORMANCE DATA - TPS™ PILOT PINS

UNIFIED	Pin Dia. Code	Test Sheet Material	Sheet Hardness HRB	Installation (lbs.)	Pushout (lbs.)
	125	Aluminum	20	4500	150
		Steel	62	6500	250
	187	Aluminum	18	6500	230
		Steel	60	8000	400
	250	Aluminum	18	7000	270
Steel		62	9000	500	

METRIC	Pin Dia. Code	Test Sheet Material	Sheet Hardness HRB	Installation (kN)	Pushout (kN)
	3MM	Aluminum	22	12	0.56
		Steel	65	22	0.98
	4MM	Aluminum	19	22	0.89
		Steel	66	26.4	1.54
	5MM	Aluminum	18	28.6	1.01
Steel		60	35.2	1.76	
6MM	Aluminum	18	30.8	1.1	
	Steel	62	39.6	2.1	

## PERFORMANCE DATA - TP4™ PILOT PINS

UNIFIED	Pin Dia. Code	Test Sheet Material	Installation (lbs.)	Pushout (lbs.)
	125	300 Series Stainless Steel	8000	350
	187	300 Series Stainless Steel	12000	570
	250	300 Series Stainless Steel	14000	650

METRIC	Pin Dia. Code	Test Sheet Material	Installation (kN)	Pushout (N)
	3MM	300 Series Stainless Steel	35	1556
	4MM	300 Series Stainless Steel	45	2335
	5MM	300 Series Stainless Steel	54	2535
	6MM	300 Series Stainless Steel	60	2891

## PERFORMANCE DATA - TPXS™ PILOT PINS

METRIC	Pin Dia. Code	Test Sheet Material	Sheet Hardness HRB	Installation (kN)	Pushout (kN)
	3MM	Aluminum	22	12	0.56
		Steel	65	22	0.98

**PEM® Dimple**  
(Registered Trademark)

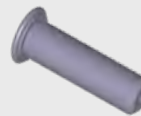

Fastener drawings and models are available at [www.pemnet.com](http://www.pemnet.com)



PEM® brand fasteners that utilize, surface-mount, broaching and flaring technology for use with PC boards



**K**<sup>TM</sup>

## FASTENERS FOR USE WITH PC BOARDS

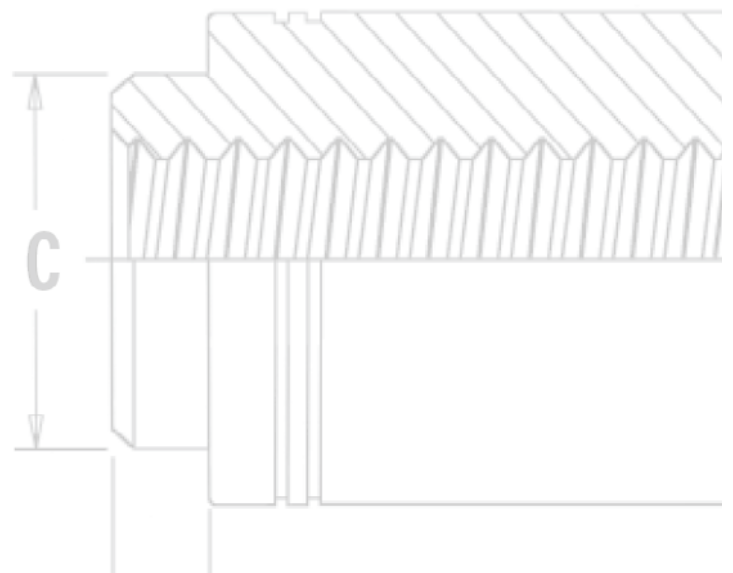
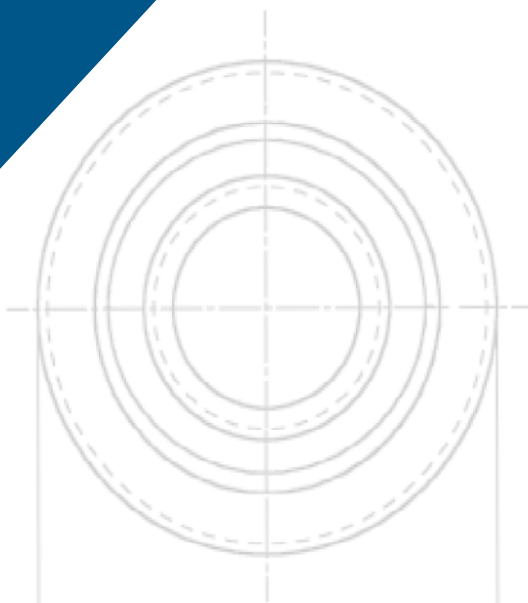

Get quote >>

Angic Global Solutions

1-888-872-0690

<https://www.AngicGlobal.com> [Sales@AngicGlobal.com](mailto:Sales@AngicGlobal.com)











# FASTENERS FOR USE WITH PC BOARDS

No matter how sophisticated or advanced, electronic components must be attached reliably and securely if they are to deliver optimum performance. We offer several fastener products for use with PC boards to satisfy component-to-board, board-to-board, and board-to-chassis attachment needs.

**ReelFast® surface mount fasteners** mount on PC boards in the same manner and at the same time as other surface mount components prior to the automated reflow solder process. The fasteners simply become another board component. This alleviates concerns about potential damage to PC boards due to improper secondary installation operations. The fasteners are provided on tape and reel compatible with existing SMT automated installation equipment. The benefits of using ReelFast® SMT fasteners are: faster assembly; reduced scrap; reduced handling; and reduced risk of board damage.

**Broaching fasteners** can also offer practical alternatives to “loose” hardware. A broaching fastener is a knurled-shank fastening device that can be pressed into a hole to provide a permanent, strong, threaded or unthreaded attachment point in PC boards. They can also be used in aluminum, acrylic, casting and polycarbonate components. Specially formed axial grooves around the shank of the fastener “broach” or cut into the material, creating a firm, interference-type fit resistant to rotation. In PC boards, broaching fasteners are recommended for use in non-plated holes.

**Broach/flare-mount standoffs** (KFB3™) offer a combined broach/flare feature for even greater pullout performance in PC board materials.

<p><b>NUTS AND SPACERS/STANDOFFS</b></p> <p><b>SMTSO™/SMTSOB™</b> - ReelFast® surface mount nuts and standoffs are available threaded and unthreaded - <b>PAGE 86</b></p> 	<p><b>PFK™</b> - Broaching panel fastener assemblies for mounting on PC boards - <b>PAGE 94</b></p> 
<p><b>SMTSS™</b> - ReelFast® SNAP-TOP® standoffs feature a spring action to hold PC board securely without screws or threaded hardware - <b>PAGE 87</b></p> 	<p><b>STUDS</b></p> <p><b>KFH™</b> - Threaded broaching studs for use as solderable connectors or as permanently mounted studs on PC boards - <b>PAGE 94</b></p> 
<p><b>SMTSK™</b> - <b>NEW</b> ReelFast® KEYHOLE® standoffs eliminate the need for attaching screws - <b>PAGE 88</b></p> 	<p><b>RIGHT ANGLE FASTENERS</b></p> <p><b>SMTRA™</b> - ReelFast® R'ANGLE® surface mount fasteners provide strong re-usable threads at right angles to PC boards - <b>PAGE 95</b></p> 
<p><b>KF2™/KFS2™</b> - Broaching nuts, internally threaded for mounting on PC boards - <b>PAGE 89</b></p> 	<p><b>SHEET JOINING FASTENERS</b></p> <p><b>SFK™</b> - SpotFast® clinch/broach mount fasteners for joining metal to PCB/plastic panels - <b>PAGE 96</b></p> 
<p><b>KFE™/KFSE™</b> - Broaching standoffs, threaded or unthreaded for stacking or spacing - <b>PAGE 90</b></p> 	<p><b>MATERIAL AND FINISH SPECIFICATIONS - PAGE 97</b></p>
<p><b>KFB3™</b> - Broach/flare-mount standoffs with greater pullout performance - <b>PAGE 90</b></p> 	<p><b>INSTALLATION - PAGES 98-100</b></p>
<p><b>KSSB™</b> - Broaching, SNAP-TOP® standoffs feature a spring action to hold PC board securely without screws or threaded hardware - <b>PAGE 91</b></p> 	<p><b>PERFORMANCE DATA - PAGES 101-102</b></p>
<p><b>CAPTIVE PANEL SCREWS</b></p> <p><b>SMTPFSLM™</b> - ReelFast® surface mount spring-loaded captive panel screws - <b>PAGE 92</b></p> 	<p><b>OTHER FASTENERS FOR USE WITH PC BOARDS - PAGE 103</b></p>
<p><b>SMTPF™</b> - ReelFast® surface mount captive panel screws - <b>PAGE 93</b></p> 	

# FASTENERS FOR USE WITH PC BOARDS

## QUICK REFERENCE CHART

PEM® Fastener	Page No.	Mounting Types				Primary Use								
		Broach	Broach/Flare	Surface Mount	Clinch/Broach	Nut	Spacer/Standoff	Snap Attachment	Stud	Captive Screw	Color Coding	Right Angle Attachment	Sheet to Sheet Joining	
SMTSO/SMTSOB	86			▪		▪	▪							
SMTSS	87			▪			▪	▪						
SMTSK	88			▪			▪							
KF2/KFS2	89	▪				▪								
KFE/KFSE	90	▪					▪							
KFB3	90		▪				▪							
KSSB	91	▪					▪	▪						
SMTPLSM	92			▪						▪				
SMTPF	93			▪						▪	▪			
PFK	94	▪								▪				
KFH	94	▪							▪					
SMTRA	95			▪								▪		
SFK	98				▪								▪	

**PEM® Dimple (Registered Trademark)**



**PEM® TRADEMARKS**

**PEM® Double Notch (Registered Trademark)**



**PEM® "Two Groove" (Registered Trademark)**



**PEM® Blue Nylon Ring (Trademark)**



To be sure that you are getting genuine PEM® brand fasteners, look for the unique PEM® product markings and identifiers.



Fastener drawings and models are available at [www.pemnet.com](http://www.pemnet.com)



Get quote »

Angic Global Solutions

1-888-872-0690

[www.angic.com](http://www.angic.com) 85

<https://www.AngicGlobal.com> Sales@AngicGlobal.com

# FASTENERS FOR USE WITH PC BOARDS

## SMTSO™/SMTSOB™ ReelFast® SURFACE MOUNT NUTS AND SPACERS/STANDOFFS

**Thread/thru hole sizes** 2-56, 4-40, 6-32, 8-32, 116, 143, M2, M2.5, M3, M3.5, M4, 3.1, 3.6, and 4.2

**microPEM® SMTSO NUTS**

**Stencil Masking Examples**

**Solder Pad**  
Mounting hole does not need to be plated through.

**PART NUMBER DESIGNATION**

SMTSO - 440 - 8 ET  
SMTSOB - 440 - 8 ET

Type and Material      Thread or Thru Hole Code      Length Code      Finish

**NOTE:** Standoffs are available on special order without a pilot that do not require a thru hole for installation. Contact [techsupport@pemnet.com](mailto:techsupport@pemnet.com) for more information

All dimensions are in inches.

UNIFIED	Thread Size	Thru Hole +.004 -.003	Type		Thread or Thru Hole Code	Length Code "L" ±.005 (Length code in 32nds of an inch)				Min. Sheet Thickness	A Max.	C Max.	E		H Nom.	ØH Hole Size In Sheet +.003 -.000	ØD Min. Solder Pad
			Fastener Material			.062	.125	.250	.375				Ref.	±.005			
			Steel	Brass													
	.060-80 (#0-80)	-	SMTSO	-	080	2	4	-	-	.020	.019	.095	.144		.125	.098	.165
	.086-56 (#2-56)	-	SMTSO	SMTSOB	256	2	4	8 <sup>(1)</sup>	12 <sup>(1)</sup>	.060	.060	.142	-	.219	-	.147	.244
	.112-40 (#4-40)	-	SMTSO	SMTSOB	440	2	4	8 <sup>(1)</sup>	12 <sup>(1)</sup>	.060	.060	.161	-	.219	-	.166	.244
	.138-32 (#6-32)	-	SMTSO	SMTSOB	632	2	4	8 <sup>(1)</sup>	12 <sup>(1)</sup>	.060	.060	.208	-	.281	-	.213	.306
	.164-32 (#8-32)	-	SMTSO	SMTSOB	832	2	4	8 <sup>(1)</sup>	12 <sup>(1)</sup>	.060	.060	.245	-	.344	-	.250	.369
	-	.116	SMTSO	SMTSOB	116	2	4	8	12	.060	.060	.161	-	.219	-	.166	.244
	-	.143	SMTSO	SMTSOB	143	2	4	8	12	.060	.060	.208	-	.281	-	.213	.306

All dimensions are in millimeters.

METRIC	Thread Size x Pitch	Thru Hole +.010 -0.08	Type		Thread or Thru Hole Code	Length Code "L" ±0.13 (Length code in millimeters)								Min. Sheet Thickness	A Max.	C Max.	E		H Nom.	ØH Hole Size In Sheet +0.08	ØD Min. Solder Pad
			Fastener Material			1	2	3	4	6	8	10	Ref.				±0.13				
			Steel	Brass																	
	S1	-	SMTSO	-	M1	1	2	3	-	-	-	-	0.5	0.48	2.41	3.66	-	3.18	2.5	4.19	
	S1.2	-	SMTSO	-	M1.2	1	2	3	-	-	-	-	0.5	0.48	2.41	3.66	-	3.18	2.5	4.19	
	S1.4	-	SMTSO	-	M1.4	1	2	3	-	-	-	-	0.5	0.48	2.41	3.66	-	3.18	2.5	4.19	
	M1.6 x 0.35	-	SMTSO	-	M1.6	1	2	3	-	-	-	-	0.5	0.48	2.41	3.66	-	3.18	2.5	4.19	
	M2 x 0.4	-	SMTSO	SMTSOB	M2	-	2	3	4 <sup>(1)</sup>	6 <sup>(1)</sup>	8 <sup>(1)</sup>	10 <sup>(1)</sup>	1.53	1.53	3.6	-	5.56	-	3.73	6.2	
	M2.5 x 0.45	-	SMTSO	SMTSOB	M2.5	-	2	3	4 <sup>(1)</sup>	6 <sup>(1)</sup>	8 <sup>(1)</sup>	10 <sup>(1)</sup>	1.53	1.53	4.09	-	5.56	-	4.22	6.2	
	M3 x 0.5	-	SMTSO	SMTSOB	M3	-	2	3	4 <sup>(1)</sup>	6 <sup>(1)</sup>	8 <sup>(1)</sup>	10 <sup>(1)</sup>	1.53	1.53	4.09	-	5.56	-	4.22	6.2	
	M3.5 x 0.6	-	SMTSO	SMTSOB	M3.5	-	2	3	4 <sup>(1)</sup>	6 <sup>(1)</sup>	8 <sup>(1)</sup>	10 <sup>(1)</sup>	1.53	1.53	5.28	-	7.14	-	5.41	7.77	
	M4 x 0.7	-	SMTSO	SMTSOB	M4	-	2	3	4	6 <sup>(1)</sup>	8 <sup>(1)</sup>	10 <sup>(1)</sup>	1.53	1.53	6.22	-	8.74	-	6.35	9.37	
	-	3.1	SMTSO	SMTSOB	3.1	-	2	3	4	6	8	10	1.53	1.53	4.09	-	5.56	-	4.22	6.2	
	-	3.6	SMTSO	SMTSOB	3.6	-	2	3	4	6	8	10	1.53	1.53	5.28	-	7.14	-	5.41	7.77	
	-	4.2	SMTSO	SMTSOB	4.2	-	2	3	4	6	8	10	1.53	1.53	6.22	-	8.74	-	6.35	9.37	

(1) SMTSOB fasteners with this length code have a shank counterbore.

### NUMBER OF PARTS PER REEL / PITCH (MM) FOR EACH SIZE

Thread/Thru-Hole Size	Length Code							
	1	2	3	4	6	8	10	12
080	-	3500 / 8	-	2000 / 8	-	-	-	-
256, 440, 632, 116, 143	-	1500 / 12	-	1000 / 12	-	650 / 12	-	300 / 16
832	-	1100 / 16	-	800 / 16	-	500 / 16	-	300 / 16
M1, M1.2, M1.4, M1.6	3500 / 8	2500 / 8	2000 / 8	-	-	-	-	-
M2, M2.5, M3, M3.5, 3.1, 3.6	-	1500 / 12	1000 / 12	900 / 12	650 / 12	375 / 16	300 / 16	-
M4, 4.2	-	1100 / 16	800 / 16	675 / 16	500 / 16	375 / 16	300 / 16	-

A polyimide patch is supplied to allow for reliable vacuum pickup. Fasteners are also available without a patch which may provide a lower cost alternative, depending on your installation methods/requirements.

Packaged on 330 mm recyclable reels. Tape width is 24 mm. Reels conform to EIA-481.

# FASTENERS FOR USE WITH PC BOARDS

## SMTSS™ REELFAST® SNAP-TOP® STANDOFFS

**NOTE: REELFAST® SNAP-TOP® SMTSS™ standoffs are for on-only applications. For removal applications, mounting hole A can be increased to reduce removal force.**

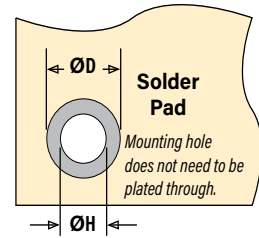
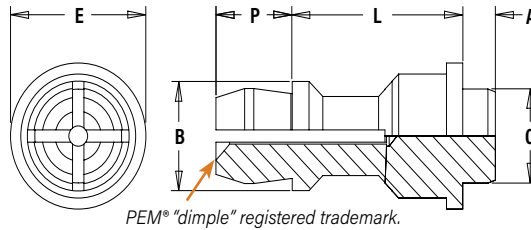
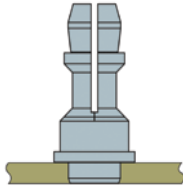

### PART NUMBER DESIGNATION

**SMTSS S - 156 - 12 ET**  
 ↓ ↓ ↓ ↓ ↓  
 Type Material Top Board Mounting Hole A Diameter Code Length Code Finish Code

### Stencil Masking Examples

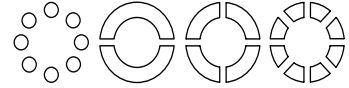

All dimensions are in inches.

UNIFIED	Top Board Mounting Hole A Diameter Code	Type and Material	Length Code "L" ±.005 (Length Code in 32nds of an inch)		Min. Sheet Thickness	A Max.	C Max.	E ±.005	B ±.005	P ±.005	ØH Hole Size in Sheet +.003 -.000	ØD Min. Solder Pad
			.250	.375								
	156	SMTSSS	8	12	.060	.060	.161	.250	.188	.141	.166	.276

All dimensions are in millimeters.

METRIC	Top Board Mounting Hole A Diameter Code	Type and Material	Length Code "L" ±0.13 (Length Code in millimeters)			Min. Sheet Thickness	A Max.	C Max.	E ±0.13	B ±0.13	P ±0.13	ØH Hole Size in Sheet +0.08	ØD Min. Solder Pad
			6	8	10								
	4MM	SMTSSS	6	8	10	1.53	1.53	4.09	6.35	4.8	3.58	4.22	7

### NUMBER OF PARTS PER REEL

Type, Material and Size	Length Code / Number of Parts per Reel		
SMTSSS-156	-8 / 280	-12 / 220	
SMTSSS-4MM	-6 / 300	-8 / 250	-10 / 200



Packaged on 330 mm recyclable reels. Tape width is 24 mm. Supplied with polyimide patch for vacuum pick up. Reels conform to EIA-481.

### SMTSS™ APPLICATION DATA

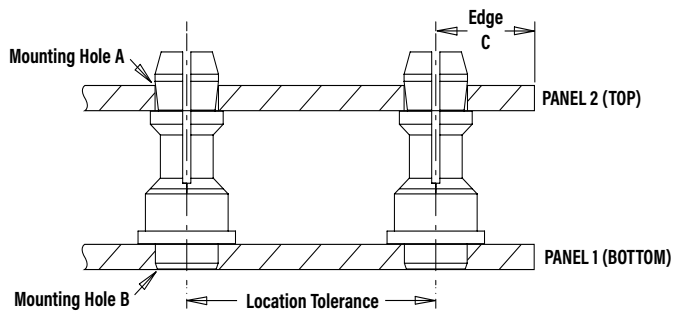

All dimensions are in inches.

UNIFIED	Type	Panel 1				Panel 2					
		Hardness Max.	Bottom Mounting Hole B +.003 -.000	Panel Material	Thickness Min.	Location Tolerance	Hardness Max.	Top Mounting Hole A +.003 -.000	Panel Material	Thickness Range	Edge Distance C Min.
	SMTSS	No Limit	.166	PC board	.060	±.005	No Limit	.156	PC board or Metal	.040 - .070	.100

All dimensions are in millimeters.

METRIC	Type	Panel 1				Panel 2					
		Hardness Max.	Bottom Mounting Hole B +0.08	Panel Material	Thickness Min.	Location Tolerance	Hardness Max.	Top Mounting Hole A +0.08	Panel Material	Thickness Range	Edge Distance C Min.
	SMTSS	No Limit	4.22	PC board	1.53	±0.13	No Limit	4	PC board or Metal	1 - 1.8	2.54



Get quote >>

Angic Global Solutions

1-888-872-0690 [www.angic.com](http://www.angic.com) 87

<https://www.AngicGlobal.com> Sales@AngicGlobal.com

# FASTENERS FOR USE WITH PC BOARDS

**NEW**

## SMTSK™ REELFAST® KEYHOLE® STANDOFFS

- Unique barrel design allows for quick attachment and detachment.
- Makes horizontal or vertical component mounting possible.

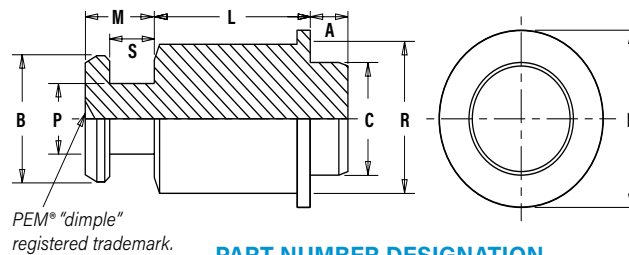
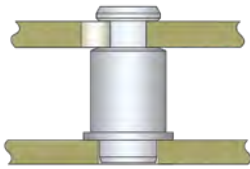

PEM® "dimple" registered trademark.

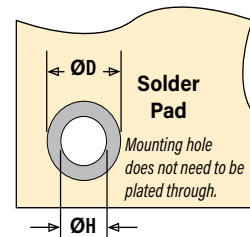

### PART NUMBER DESIGNATION

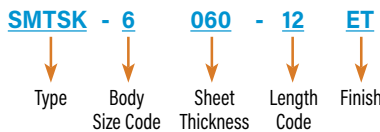

All dimensions are in inches.

UNIFIED	Type	Body Size - Sheet Code	Length "L" ± .005 (Length Code in 32nds of an inch)			Min. Sheet Thickness	A Max.	C Max.	E ±.005	B ±.003	P ±.003	R Max.	S ±.003	M Max.	ØH Hole Size in Sheet +.003 -.000	ØD Min. Solder Pad
			.125	.250	.375											
SMTSK	6060		4	8	12	.060	.060	.161	.250	.177	.099	.212	.068	.108	.166	.276

All dimensions are in millimeters.

METRIC	Type	Body Size - Sheet Code	Length "L" ± 0.13 (Length Code in millimeters)					Min. Sheet Thickness	A Max.	C Max.	E ±0.13	B ±0.08	P ±0.08	R Max.	S ±0.08	M Max.	ØH Hole Size in Sheet +0.08	ØD Min. Solder Pad
			3	4	6	8	10											
SMTSK	61.5		3	4	6	8	10	1.53	1.53	4.09	6.35	4.5	2.51	5.39	1.73	2.75	4.22	7

### NUMBER OF PARTS PER REEL

Part Number	Length Code "L"		
	.125	.250	.375
SMTSK-6060	4	8	12
	630	440	230

Part Number	Length Code "L"				
	3	4	6	8	10
SMTSK-61.5	640	540	440	260	220

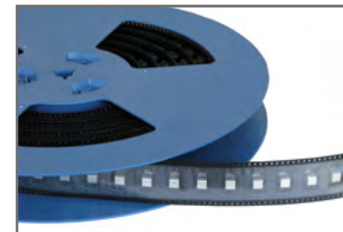

Packaged on 13" recyclable reels. Tape width is 24mm and 16mm. Pitch is 16mm and 12mm. Reels conform to EIA-481.

### APPLICATION DATA

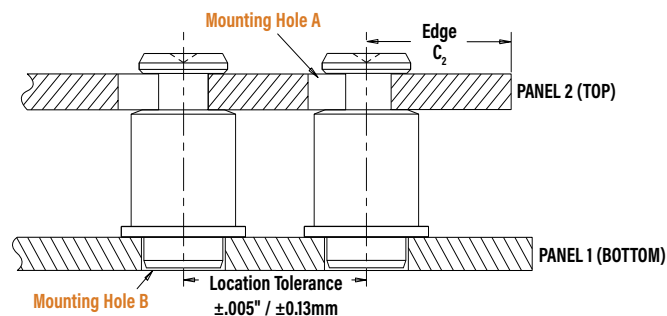
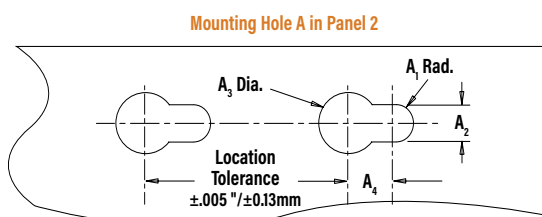

All dimensions are in inches.

UNIFIED	Type	Panel 1				Panel 2							
		Hardness Max.	Bottom Mounting Hole B +.003 -.000	Panel Material	Thickness Min.	Location Tolerance	Top Mounting Hole A				Panel Material	Thickness Range	Edge Distance C <sub>2</sub> Min.
							A <sub>1</sub> Nom.	A <sub>2</sub> ±.003	A <sub>3</sub> ±.003	A <sub>4</sub> Min.			
SMTSK	No Limit	.166	PC board	.060	±.005	.059	.118	.197	.148	ANY	.057 - .064	.160	

All dimensions are in millimeters.

METRIC	Type	Panel 1				Panel 2							
		Hardness Max.	Bottom Mounting Hole B +0.08	Panel Material	Thickness Min.	Location Tolerance	Top Mounting Hole A				Panel Material	Thickness Range	Edge Distance C <sub>2</sub> Min.
							A <sub>1</sub> Nom.	A <sub>2</sub> ±0.08	A <sub>3</sub> ±0.08	A <sub>4</sub> Min.			
SMTSK	No Limit	4.22	PC board	1.53	±0.13	1.5	3	5	3.75	ANY	1.45 - 1.62	4.1	



# FASTENERS FOR USE WITH PC BOARDS

## NOTE ABOUT PLATED AND UNPLATED MOUNTING HOLES FOR BROACHING FASTENERS

Broaching and broach/flare types are designed for unplated mounting hole applications. If used in plated mounting holes, the stresses involved can damage the plating, push out the plating entirely, or break any traces inside the board that might be connected to the plated hole. When installing into non-plated mounting holes there may even be issues with delamination, measeling or crazing in some instances.

Increasing the mounting hole size +.005" to +.008" / +0.13 mm to +0.2 mm may relieve these conditions. If increasing the mounting hole does not correct the issue then we recommend our surface-mount type fasteners.

It is always recommended that you try the fasteners in your specific application before full production begins. We are happy to provide samples for this purpose.

General recommendations for "Keep Out" areas are the same as our "Min. Distance Hole C/L to Edge" dimensions stated in the dimensional charts of our bulletin.

## KF2™/KFS2™ BROACHING NUTS

- Can be used in aluminum, acrylic, casting and polycarbonate components

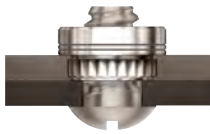

### PART NUMBER DESIGNATION

**KFS2** - **832**

**KF2** - **832** - **ET**

Type and Material

Thread Code

Finish

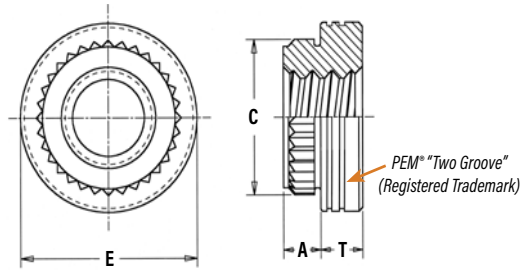

All dimensions are in inches.

UNIFIED	Thread Size	Type		Thread Code	A (Shank) Max.	Min. Sheet Thickness	Hole Size In Sheet +.003-.000	C ±.003	E ±.005	T ±.005	Min. Dist. Hole To Edge
		Carbon Steel	Stainless Steel								
	.086-56 (#2-56)	KF2	KFS2	256	.060	.060	.147	.165	.219	.065	0.16
	.112-40 (#4-40)	KF2	KFS2	440	.060	.060	.166	.184	.219	.065	0.17
	.138-32 (#6-32)	KF2	KFS2	632	.060	.060	.213	.231	.281	.065	0.22
	.164-32 (#8-32)	KF2	KFS2	832	.060	.060	.250	.268	.344	.096	0.25
	.190-32 (#10-32)	KF2	KFS2	032	.060	.060	.272	.290	.375	.127	0.28

All dimensions are in millimeters.

METRIC	Thread Size x Pitch	Type		Thread Code	A (Shank) Max.	Min. Sheet Thickness	Hole Size In Sheet +0.08	C ±0.08	E ±0.13	T ±0.13	Min. Dist. Hole To Edge
		Carbon Steel	Stainless Steel								
	M2 x 0.4	KF2	KFS2	M2	1.53	1.53	3.73	4.19	5.56	1.5	4.2
	M2.5 x 0.45	KF2	KFS2	M2.5	1.53	1.53	4.22	4.68	5.56	1.5	4.4
	M3 x 0.5	KF2	KFS2	M3	1.53	1.53	4.22	4.68	5.56	1.5	4.4
	M4 x 0.7	KF2	KFS2	M4	1.53	1.53	6.4	6.81	8.74	2	6.4
	M5 x 0.8	KF2	KFS2	M5	1.53	1.53	6.9	7.37	9.53	3	7.1



Get quote »

Angic Global Solutions

1-888-872-0690 [www.angic.com](http://www.angic.com) 89

<https://www.AngicGlobal.com> Sales@AngicGlobal.com

# FASTENERS FOR USE WITH PC BOARDS

## KFE™/KFSE™ BROACHING STANDOFFS



### PART NUMBER DESIGNATION

**KFSE** - **632** - **12**      **ET**  
 ↓                                      ↓                                      ↓  
 Type and                              Thread                                      Length  
 Material                              or Thru Hole                              Code  
 Code                                      Finish

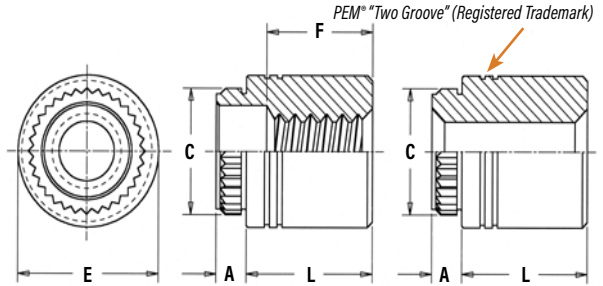

All dimensions are in inches.

UNIFIED	Thread Size	Thru Hole +0.04 -0.03	Type		Thread or Thru Hole Code	Length "L" ±.005 (Length Code is in 32nds of an inch)								A (Shank) Max.	Min. Sheet Thickness	Hole Size In Sheet +0.03 -0.00	C ±.003	E ±.005	Min. Dist. Hole To Edge
			Carbon Steel	Stainless Steel		.125	.250	.375	.500	.625	(1) .750	(1) .875	(1) 1.00						
						Full			.375 ± .016		.375 Blind								
.112-40 (#4-40)	-	-	KFE	KFSE	440	4	8	12	16	20	24	-	-	.060	.060	.166	.184	.219	.17
.138-32 (#6-32)	-	-	KFE	KFSE	632	4	8	12	16	20	24	28	32	.060	.060	.213	.231	.281	.22
-	.116	-	KFE	KFSE	116	4	8	12	16	20	24	-	-	.060	.060	.166	.184	.219	.17
-	.143	-	KFE	KFSE	143	4	8	12	16	20	24	28	32	.060	.060	.213	.231	.281	.22

All dimensions are in millimeters.

METRIC	Thread Size x Pitch	Thru Hole +0.10 -0.08	Type		Thread or Thru Hole Code	Length "L" ±0.13 (Length Code is in millimeters)								A (Shank) Max.	Min. Sheet Thickness	Hole Size In Sheet +0.08	C ±0.08	E ±0.13	Min. Dist. Hole To Edge
			Carbon Steel	Stainless Steel		3	4	6	8	10	12	14	16						
						Full			9.5 ± 0.4										
M3 x 0.5	-	-	KFE	KFSE	M3	3	4	6	8	10	12	14	16	1.53	1.53	4.22	4.68	5.56	4.4
-	3.6	-	KFE	KFSE	3.6	3	4	6	8	10	12	14	16	1.53	1.53	5.41	5.87	7.14	5.5
-	4.2	-	KFE	KFSE	4.2	3	4	6	8	10	12	14	16	1.53	1.53	6.4	6.81	8.74	7.1

## KFB3™ BROACH/FLARE-MOUNT STANDOFFS



### PART NUMBER DESIGNATION

**KFB3** - **632** - **12**      **ET**  
 ↓                                      ↓                                      ↓                                      ↓  
 Type and                              Thread                                      Length                                      Finish  
 Material                              Code                                      Code

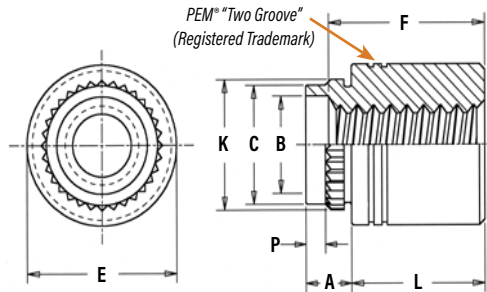

All dimensions are in inches.

UNIFIED	Thread Size	Type	Thread Code	Length "L" ±.005 (Length Code is in 32nds of an inch)										A (Shank) Max.	Sheet Thickness	Hole Size in Sheet +0.05 -0.01	B ±.003	C Max.	E ±.005	K ±.003	P ±.010	Min. Dist. Hole To Edge
				.062	.125	.187	.250	.312	.375	.500	.625	(1) .750	(1) 1.00									
						Full			.375 Blind													
.112-40 (#4-40)	KFB3	440	2	4	6	8	10	12	16	20	-	-	.09	.050-.065	.166	.122	.165	.219	.179	.040	.17	
.138-32 (#6-32)	KFB3	632	2	4	6	8	10	12	16	20	24	32	.09	.050-.065	.213	.171	.212	.280	.226	.040	.22	

All dimensions are in millimeters.

METRIC	Thread Size x Pitch	Type	Thread Code	Length "L" ±0.13 (Length Code is in millimeters)										A (Shank) Max.	Sheet Thickness	Hole Size in Sheet +0.13 -0.03	B ±0.08	C Max.	E ±0.13	K ±0.08	P ±0.25	Min. Dist. Hole To Edge
				2	3	4	6	8	10	12	14	16										
						Full			9.5 ± 0.4													
M3 x 0.5	KFB3	M3	2	3	4	6	8	10	12	14	16	2.29	1.27-1.65	4.22	3.23	4.2	5.56	4.55	1	4.33		
M4 x 0.7	KFB3	M4	2	3	4	6	8	10	12	14	16	2.29	1.27-1.65	6.4	5.23	6.33	8.74	6.68	1	6.36		

(1) Blind at shank end with .375" minimum thread length from head end.

# FASTENERS FOR USE WITH PC BOARDS

## KSSB™ BROACHING SNAP-TOP® STANDOFFS



### PART NUMBER DESIGNATION

**KSSB - 156 - 12 X**

↓                      ↓                      ↓                      ↓

Type and          Top Board          Length          Finish

Material          Mounting          Code          Code

Hole A          Diameter

Code

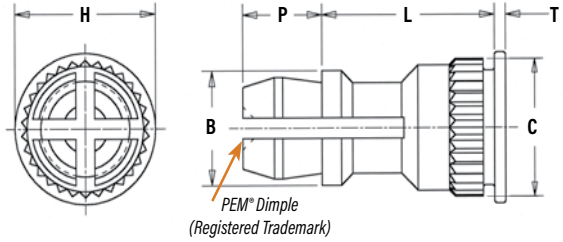

All dimensions are in inches.

UNIFIED	Type	Top Board Mounting Hole A Diameter Code	Length "L" ±.005 (Length Code is in 32nds of an inch)										B ±.005	C ±.003	H ±.005	P ±.005	T ±.005
			.250	.312	.375	.437	.500	.562	.625	.750	.875	1.00					
KSSB	156	8	10	12	14	16	18	20	24	28	32	.188	.226	.250	.141	.020	

All dimensions are in millimeters.

METRIC	Type	Top Board Mounting Hole A Diameter Code	Length "L" ±0.13 (Length Code is in millimeters)										B ±0.13	C ±0.08	H ±0.13	P ±0.13	T ±0.13
			8	10	12	14	16	18	20	22	25						
KSSB	4MM	8	10	12	14	16	18	20	22	25	4.8	5.74	6.35	3.58	0.51		

## KSSB™ APPLICATION DATA

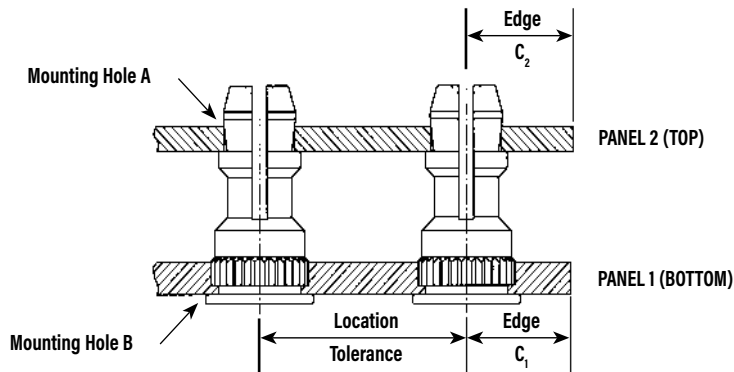

All dimensions are in inches.

UNIFIED	Type	Panel 1					Panel 2					
		Hardness Max. (1)	Bottom Mounting Hole B +.003 -.000	Panel Material	Thickness Min.	Edge Distance C, Min.	Location Tolerance	Hardness Max.	Top Mounting Hole A +.003 -.000	Panel Material	Thickness Range (2)	Edge Distance C, Min.
KSSB		HRB 65 / HB 116	.213	PC board	.050	.220	±.005	No Limit	.156	PC board or Metal	.040 - .070	.100

All dimensions are in millimeters.

METRIC	Type	Panel 1					Panel 2					
		Hardness Max. (1)	Bottom Mounting Hole B +0.08	Panel Material	Thickness Min.	Edge Distance C, Min.	Location Tolerance	Hardness Max.	Top Mounting Hole A +0.08	Panel Material	Thickness Range (2)	Edge Distance C, Min.
KSSB		HRB 65 / HB 116	5.41	PC board	1.27	5.59	±0.13	No Limit	4	PC board or Metal	1 - 1.8	2.54

(1) HRB - Hardness Rockwell "B" Scale. HB - Hardness Brinell.

(2) Available for thicker boards on special order.



Get quote >>

Angic Global Solutions

1-888-872-0690 [www.angic.com](http://www.angic.com) 91

<https://www.AngicGlobal.com> Sales@AngicGlobal.com

# FASTENERS FOR USE WITH PC BOARDS

## SMTPF LSM™ ReelFast® SURFACE MOUNT CAPTIVE PANEL SCREWS

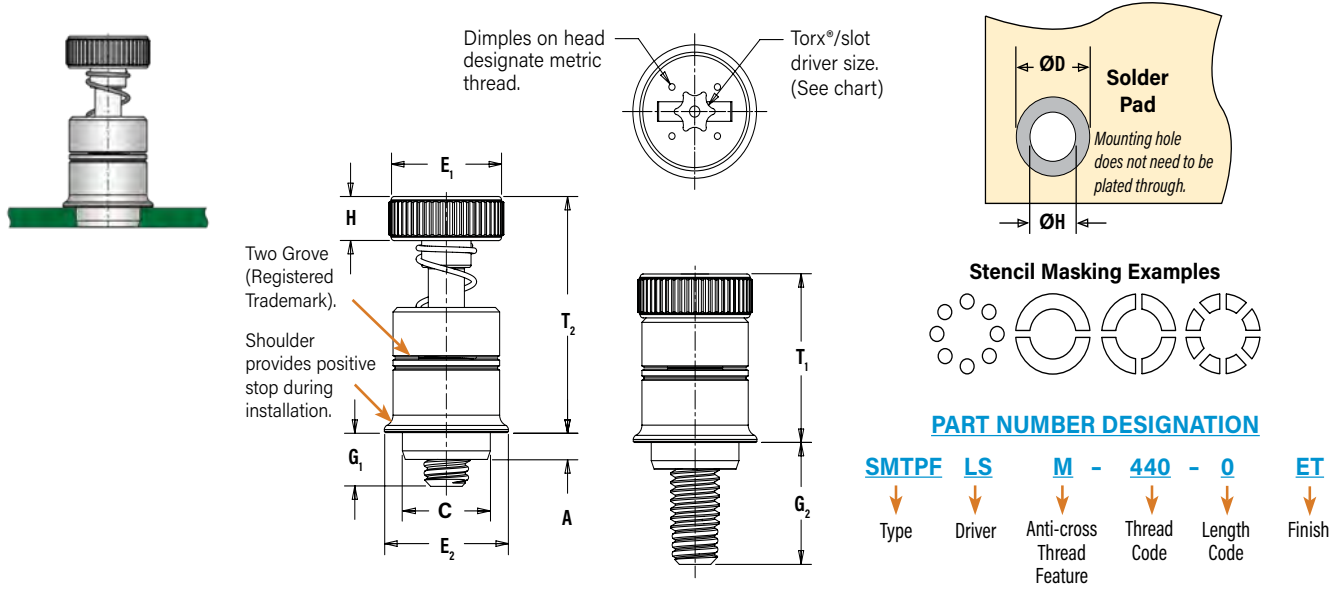

All dimensions are in inches.

UNIFIED	Thread Size	Type	Thread Code	Screw Length Code	A (Shank) Max.	Min. Sheet Thickness	C Max.	E <sub>1</sub> ±.010	E <sub>2</sub> Nom.	G <sub>1</sub> ±.025	G <sub>2</sub> ±.025	H ±.010	T <sub>1</sub> Nom.	T <sub>2</sub> Nom.	ØK Hole Size in Sheet +.003 -.000	ØD Min. Solder Pad	Driver Size
	.112-40 (#4-40)	SMTPF LSM	440	0 1	.063	.063	.215	.280	.300	.040 .100	.210 .270	.100	.38	.55	.220	.340	T15
.138-32 (#6-32)	SMTPF LSM	632	0 1	.063	.063	.247	.310	.320	.040 .100	.240 .300	.100	.42	.62	.252	.400	T15	

All dimensions are in millimeters.

METRIC	Thread Size	Type	Thread Code	Screw Length Code	A (Shank) Max.	Min. Sheet Thickness	C Max.	E <sub>1</sub> ±0.25	E <sub>2</sub> Nom.	G <sub>1</sub> ±0.64	G <sub>2</sub> ±0.64	H ±0.25	T <sub>1</sub> Nom.	T <sub>2</sub> Nom.	ØK Hole Size in Sheet +0.08	ØD Min. Solder Pad	Driver Size
	M3 x 0.5	SMTPF LSM	M3	0 1	1.6	1.6	5.46	7	76	1 2.5	5.3 6.8	2.5	9.6	14	5.6	8.6	T15
M3.5 x 0.6	SMTPF LSM	M3.5	0 1	1.6	1.6	6.27	7.9	8.13	1 2.5	6.1 7.62	2.5	10.7	15.7	6.4	10.2	T15	

### NUMBER OF PARTS PER REEL

Thread Size	Parts Per Reel
440	200
632	150
M3	200
M3.5	150



Packaged on 330 mm recyclable reels. Tape width is 24 mm. Supplied with polyimide patch for vacuum pick up. Reels conform to EIA-481.

# FASTENERS FOR USE WITH PC BOARDS

## SMTPF™ ReelFast® SURFACE MOUNT CAPTIVE PANEL SCREWS

Patented.

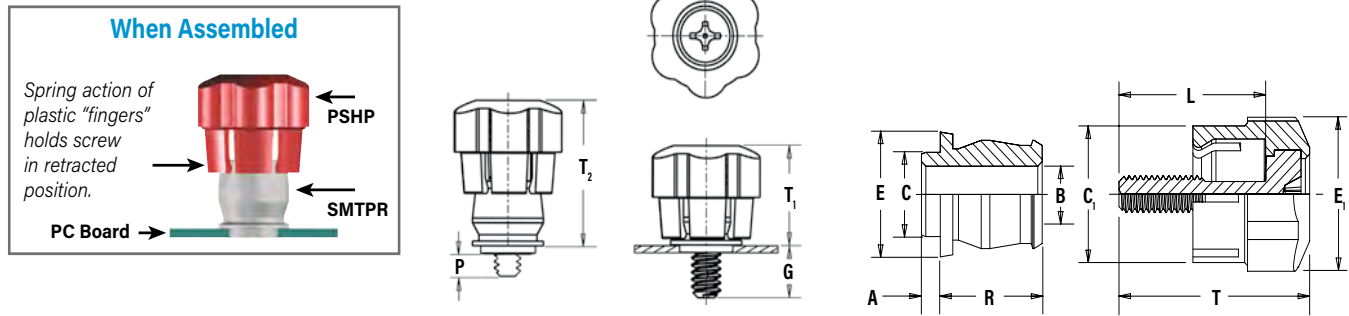

All dimensions are in inches.

UNIFIED	Screw Part Number				Retainer Part Number	Assembly Dimensions					Screw Dimensions				Retainer Dimensions					
	Thread Size	Type	Thread Code	Screw Length Code		G	P	T <sub>1</sub>	T <sub>2</sub>	Total Radial Float	C <sub>1</sub>	E <sub>1</sub>	L	T	A (Shank) Max.	Min. Sheet Thick.	B ±.003	C Max.	E Nom.	R ±.005
						±.025	±.025	Nom.	Nom.		±.010	±.010	±.015	Nom.						
	.112-40 (#4-40)	PSHP	440	0	.188	.000	.478	.646	.015	.440	.542	.510	.663	.060	.060	.167	.249	.375	.325	
				1																SMTPR-6-1
	.138-32 (#6-32)	PSHP	632	0	.188	.000	.478	.646	.020	.440	.542	.510	.663	.060	.060	.167	.249	.375	.325	
				1																SMTPR-6-1

All dimensions are in millimeters.

METRIC	Screw Part Number				Retainer Part Number	Assembly Dimensions					Screw Dimensions				Retainer Dimensions					
	Thread Size x Pitch	Type	Thread Code	Screw Length Code		G	P	T <sub>1</sub>	T <sub>2</sub>	Total Radial Float	C <sub>1</sub>	E <sub>1</sub>	L	T	A (Shank) Max.	Min. Sheet Thick.	B ±.008	C Max.	E Nom.	R ±.013
						±.064	±.064	Nom.	Nom.		±.025	±.025	±.038	Nom.						
	M3 x 0.5	PSHP	M3	0	4.78	0	12.14	16.41	.38	11.18	13.77	12.95	16.84	1.53	1.53	4.24	6.33	9.53	8.26	
				1																SMTPR-6-1
	M3.5 x 0.6	PSHP	M3.5	0	4.78	0	12.14	16.41	.51	11.18	13.77	12.95	16.84	1.53	1.53	4.24	6.33	9.53	8.26	
				1																SMTPR-6-1

**RETAINER** - Packaged on 330 mm recyclable reels of 400 pieces. Tape width is 24 mm. Supplied with Kapton® patch for vacuum pick up. Reels conform to EIA-481.

**SCREW** - Packaged in bags. Retainers and screws are sold separately.

### PART NUMBER DESIGNATION FOR SCREW

**PSHP - 632 - 0 L 001**

Type      Thread Code      Length Code      Cap Style (Lobed)      Color Code (Standard Black)

### PART NUMBER DESIGNATION FOR RETAINER

**SMTPR - 6 - 1 ET**

Type      Retainer Size      Shank Code      Finish

### COLOR CAPABILITIES FOR TYPE PSHP SCREW

The colors shown here (codes #002 thru #007) are non-stocked standards and available on special order. Since actual cap colors may vary slightly from those shown here, we recommend that you request samples for color verification. If you require a custom color or you need a "color matched" cap, please contact us.

Std. Black #001    Red #002    Orange #003    Yellow #004



Non-flammable UL 94-V0 plastic caps are available on special order.

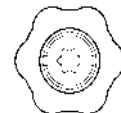

Available with Torx® recess on special order.

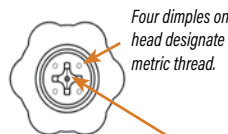

Four dimples on head designate metric thread.

**Metal Phillips Recess**  
#4-40 & M3 = #1  
#6-32 & M3.5 = #2

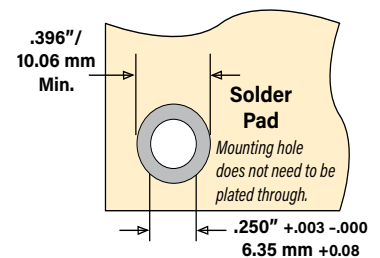

### Stencil Masking Examples



Get quote >>

Angic Global Solutions

1-888-872-0690 [www.angic.com](http://www.angic.com) 93

<https://www.AngicGlobal.com> Sales@AngicGlobal.com

# FASTENERS FOR USE WITH PC BOARDS

## PFK™ BROACHING CAPTIVE PANEL SCREWS

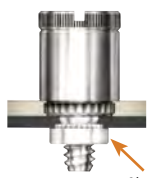

Shown here with self-clinching mating nut

### PART NUMBER DESIGNATION

**PFK** - **632** - **62**

Type                      Thread Code                      Screw Length Code

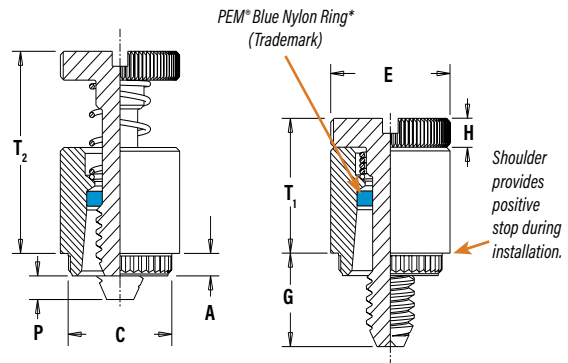
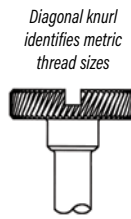

All dimensions are in inches.

UNIFIED	Thread Size	Type	Thread Code	Screw Length Code	A (Shank) Max.	Min. Sheet Thickness	Hole Size In Sheet +.003 -.000	C ±.003	E ±.010	G ±.016	H ±.005	P ±.025	T <sub>1</sub> Max.	T <sub>2</sub> Nom.	Min. Dist. Hole $\varnothing$ To Edge
	.112-40 (#4-40)	PFK	440	40	.060	.060	.265	.283	.312	.250	.072	.000	.36	.54	.20
			62						.375		.125				
			84						.500		.250				
.138-32 (#6-32)	PFK	632	40	.060	.060	.281	.299	.344	.250	.072	.000	.36	.54	.26	
			62						.375		.125				
			84						.500		.250				

All dimensions are in millimeters.

METRIC	Thread Size x Pitch	Type	Thread Code	Screw Length Code	A (Shank) Max.	Min. Sheet Thickness	Hole Size In Sheet +0.08	C ±0.08	E ±0.25	G ±0.4	H ±0.13	P ±0.64	T <sub>1</sub> Max.	T <sub>2</sub> Nom.	Min. Dist. Hole $\varnothing$ To Edge
	M3 x 0.5	PFK	M3	40	1.53	1.53	6.73	7.19	7.92	6.4	1.83	0	9.14	13.72	5.08
			62						9.5		3.2				
			84						12.7		6.4				

\*Retaining rings are plastic with normal 250°F / 120°C temperature limit.

## KFH™ BROACHING STUDS



### PART NUMBER DESIGNATION

**KFH** - **632** - **8** **ET**

Type and Material                      Thread Code                      Length Code                      Finish

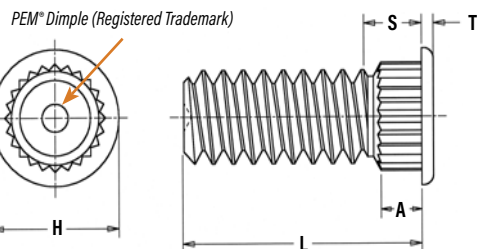

All dimensions are in inches.

UNIFIED	Thread Size	Type	Thread Code	Length "L" ±.010 (Length Code is in 16ths of an inch)					A (Shank) Max.	Min. Sheet Thickness	Hole Size in Sheet +.003 -.000	Max. Hole Size in Attached Parts	H ±.010	S Max. (I)	T ±.005	Min. Dist. Hole $\varnothing$ To Edge
				.250	.312	.375	.500	.625								
.112-40 (#4-40)	KFH	440	4	5	6	8	10	12	.065	.060	.120	.145	.180	.09	.020	.15
.138-32 (#6-32)	KFH	632	4	5	6	8	10	12	.065	.060	.140	.170	.200	.09	.020	.19
.164-32 (#8-32)	KFH	832	4	5	6	8	10	12	.065	.060	.166	.195	.225	.09	.020	.20
.190-32 (#10-32)	KFH	032	4	5	6	8	10	12	.065	.060	.189	.220	.250	.09	.020	.20

All dimensions are in millimeters.

METRIC	Thread Size x Pitch	Type	Thread Code	Length "L" ±0.25 (Length Code is in millimeters)					A (Shank) Max.	Min. Sheet Thickness	Hole Size in Sheet +0.08	Max. Hole Size in Attached Parts	H ±0.25	S Max. (I)	T ±0.13	Min. Dist. Hole $\varnothing$ To Edge
				6	8	10	12	15								
M3 x 0.5	KFH	M3	6	8	10	12	15	18	1.65	1.53	3	3.7	4.58	2.3	0.51	3.8
M4 x 0.7	KFH	M4	6	8	10	12	15	18	1.65	1.53	4.2	4.8	5.74	2.3	0.51	5.1
M5 x 0.8	KFH	M5	6	8	10	12	15	18	1.65	1.53	5	5.8	6.6	2.3	0.51	5.3

(1) Threads are gaugeable to within 2 pitches of the "S" Max. dimension. A class 3B/5H maximum material commercial nut shall pass up to the "S" Max. dimension.

# FASTENERS FOR USE WITH PC BOARDS

## SMTRA™ ReelFast® SURFACE MOUNT RIGHT ANGLE (R'ANGLE®) FASTENERS

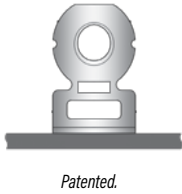

### PART NUMBER DESIGNATION

**SMTRA**   **256** - **8** - **6**   **ET**  
 ↓            ↓            ↓            ↓            ↓  
 Type        Thread Code    Height Code    Length Code    Finish

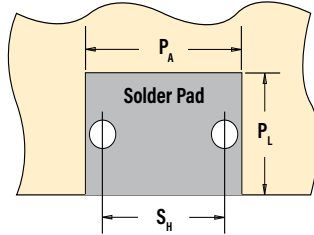

Solder pad can be flush to edge.  
 Mounting holes do not need to be plated through.

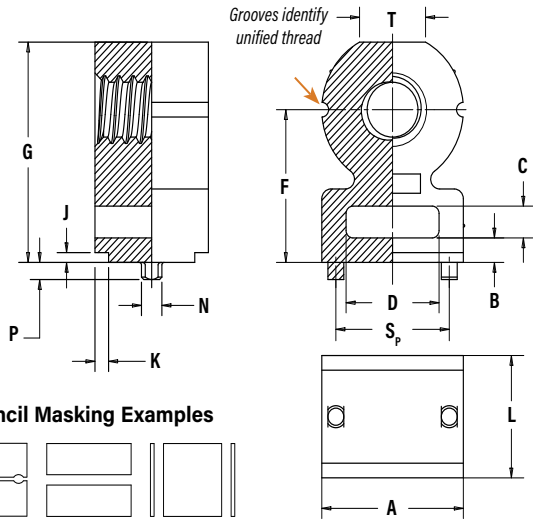

### Stencil Masking Examples

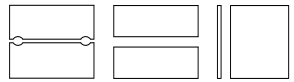

All dimensions are in inches.

UNIFIED	Thread Size	Type	Thread Code	Height Code	Length Code	Length L ±.005	Min. Sheet Thickness	Hole Size In Sheet +.003 -.000	A ±.006	B ±.006	C ±.006	D ±.006	Height F ±.006	G ±.006	J Nom.	K Nom.	N Max.	P Max.	S <sub>p</sub> ±.003	T Nom.
	.086-56 (#2-56)	SMTRA	256	8	6	.188	.040	.053	.218	.040	.060	.140	.250	.345	.020	.030	.048	.040	.157	.105
.112-40 (#4-40)	SMTRA	440	9	6	.188	.040	.053	.250	.050	.065	.160	.281	.390	.020	.030	.048	.040	.188	.125	
.138-32 (#6-32)	SMTRA	632	10	8	.250	.040	.053	.312	.050	.065	.205	.312	.450	.020	.030	.048	.040	.250	.145	
.164-32 (#8-32)	SMTRA	832	12	9	.281	.040	.053	.375	.050	.075	.250	.375	.535	.020	.030	.048	.040	.312	.195	

All dimensions are in millimeters.

METRIC	Thread Size x Pitch	Type	Thread Code	Height Code	Length Code	Length L ±0.13	Min. Sheet Thickness	Hole Size In Sheet +0.08	A ±0.15	B ±0.15	C ±0.15	D ±0.15	Height F ±0.15	G ±0.15	J Nom.	K Nom.	N Max.	P Max.	S <sub>p</sub> ±0.08	T Nom.
	M2 x 0.4	SMTRA	M2	6	5	5	1	1.35	5.5	1	1.5	3.5	6	8.4	0.5	0.75	1.22	1	4	2.65
M2.5 x 0.45	SMTRA	M25	6	5	5	1	1.35	5.5	1	1.5	3.5	6	8.4	0.5	0.75	1.22	1	4	2.65	
M3 x 0.5	SMTRA	M3	7	5	5	1	1.35	6.35	1.25	1.65	4	7	9.75	0.5	0.75	1.22	1	4.75	3.2	
M4 x 0.7	SMTRA	M4	9	7	7	1	1.35	9.53	1.25	1.65	6.35	9	13.1	0.5	0.75	1.22	1	7.9	4.8	

UNIFIED	Thread Code	Pad Width P <sub>A</sub> Min.	Pad Length P <sub>L</sub> Min.	Hole Spacing S <sub>H</sub> ±.002	Hole Size In Sheet +.003 -.000
	256	.262	.171	.157	.053
	440	.294	.171	.188	.053
	632	.356	.233	.250	.053
	832	.419	.264	.312	.053

METRIC	Thread Code	Pad Width P <sub>A</sub> Min.	Pad Length P <sub>L</sub> Min.	Hole Spacing S <sub>H</sub> ±0.05	Hole Size In Sheet +0.08
	M2	6.62	4.57	4	1.35
	M25	6.62	4.57	4	1.35
	M3	7.47	4.57	4.75	1.35
M4	10.65	6.57	7.9	1.35	

Part Number	Parts Per Reel	Pitch (mm)	Tape Width (mm)
SMTRA256-8-6	375	16	24
SMTRA440-9-6	300	16	24
SMTRA632-10-8	200	20	32
SMTRA832-12-9	200	20	32
SMTRAM2-6-5	375	16	24
SMTRAM25-6-5	375	16	24
SMTRAM3-7-5	300	16	24
SMTRAM4-9-7	200	20	32



Get quote >>

Angic Global Solutions

1-888-872-0690 [www.angic.com](http://www.angic.com) 95

<https://www.AngicGlobal.com> Sales@AngicGlobal.com

# FASTENERS FOR USE WITH PC BOARDS

## SFK™ SpotFast® CLINCH/BROACH MOUNT FASTENERS

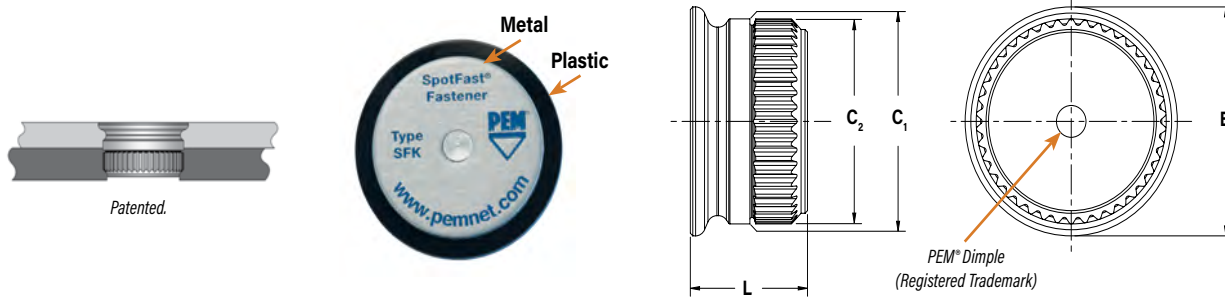

Type and Size	Thickness Code	Panel 1				Panel 2				C <sub>1</sub> Max.		C <sub>2</sub> ±0.08 mm / ±.003"		E Max.		L Max.		Min. Dist Hole ⌀ To Edge	
		Thickness ±0.08 mm / ±.003"		Mounting Hole +0.08 mm / +.003" - .000"		Thickness Min. (1)		Mounting Hole +0.08 mm / +.003" - .000"											
		mm	in.	mm	in.	mm	in.	mm	in.	mm	in.	mm	in.	mm	in.	mm	in.	mm	in.
SFK-3	0.8	0.8	.031	3	.118	1.6	.063	2.5	.098	2.98	.117	2.9	.114	3.53	.139	2.31	.091	3	0.12
SFK-3	1.0	1	.039	3	.118	1.6	.063	2.5	.098	2.98	.117	2.9	.114	3.76	.148	2.51	.099	3	0.12
SFK-3	1.2	1.2	.047	3	.118	1.6	.063	2.5	.098	2.98	.117	2.9	.114	3.76	.148	2.72	.107	3	0.12
SFK-3	1.6	1.6	.063	3	.118	1.6	.063	2.5	.098	2.98	.117	2.9	.114	3.76	.148	3.12	.123	3	0.12
SFK-5	0.8	0.8	.031	5	.197	1.6	.063	4.5	.177	4.98	.196	4.9	.193	5.56	.219	2.31	.091	5.1	0.20
SFK-5	1.0	1	.039	5	.197	1.6	.063	4.5	.177	4.98	.196	4.9	.193	5.56	.219	2.51	.099	5.1	0.20
SFK-5	1.2	1.2	.047	5	.197	1.6	.063	4.5	.177	4.98	.196	4.9	.193	5.56	.219	2.72	.107	5.1	0.20
SFK-5	1.6	1.6	.063	5	.197	1.6	.063	4.5	.177	4.98	.196	4.9	.193	5.56	.219	3.12	.123	5.1	0.20

(1) Fastener will provide flush application at minimum sheet thickness.

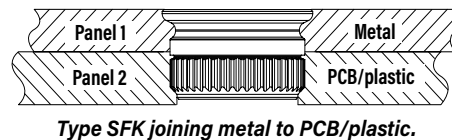

Type SFK joining metal to PCB/plastic.

### PART NUMBER DESIGNATION

SFK - 3 - 0.8 - Z1

↓                      ↓                      ↓                      ↓

Type                      Panel 1 Mounting Hole Code                      Thickness Code                      Finish

# FASTENERS FOR USE WITH PC BOARDS

## MATERIAL AND FINISH SPECIFICATIONS

Type	Threads <sup>(1)</sup>		Fastener Materials					Standard Finishes			Optional Finish		For Use in Sheet Hardness: <sup>(3)</sup>				
	Internal, ASME B1.1 2B/ ASME B1.13M 6H	External, ASME B1.1 2A/ ASME B1.13M 6g	Lead-Free Carbon Steel	300 Series Stainless Steel	CDA-510 Phosphor Bronze	Brass	Nylon, Temp. Limit 200° F/ 93° C	Passivated and/or Tested Per ASTM A380	Electro-Plated Tin ASTM B 545, Class B With Clear Preservative Coating, annealed <sup>(4)</sup>	No Finish	Electro-Plated Tin ASTM B 545, Class B With Clear Preservative Coating, annealed <sup>(4)</sup>	Black Nitride	HRB 70 / HB 125 or Less	HRB 65 / HB 116 or Less	HRB 60 / HB 107 or Less	HRB 55 / HB 96 or Less	Aluminum, Acrylic, Castings, Polycarbonate, and PC board
KF2	•		•					•							•		•
KFS2	•			•				•									•
KFE	•		•					•									•
KFSE	•			•				•									•
KFB3	•						•			•							•
KSSB							•			•							•
KFH		•			•					•						•	•
PFK																	
Retainer				•				•								•	•
Screw		•		•				•									•
Spring				•													
Retaining Ring																	
Part Number Codes For Finishes								None	ET	X	ET	BN					

Type	Threads <sup>(1)</sup>		Fastener Materials					Standard Finishes <sup>(2)</sup>			For Use in Sheet Hardness: <sup>(3)</sup>		
	Miniature ISO 1501, 4H6	Internal, ASME B1.1 2B/ ASME B1.13M 6H	External, ASME B1.1 2A/ ASME B1.13M 6g	Lead-Free Carbon Steel	Hardened Carbon Steel	300 Series Stainless Steel	Brass	Zinc Diecast	Zinc Plated per ASTM B633, SCl (5µm), Type II, Colorless	Electro-Plated Tin ASTM B 545, Class A With Clear Preservative Coating, annealed <sup>(4)</sup>	Bright Nickel Over Copper Flash	HRB 80 / HB 150 or less	PC board
SMTSO	• S1 to S1.4	• 0-80 to 8-32/ M1.6 to M4		•					•				•
SMTSOB		•					•		(6)				•
SMTRA		•						•					•
SMPFLSM													
Retainer				•					•				•
Screw				•					•				•
Spring													
PSHP <sup>(5)</sup>				•							•		
SMTPR				•					•				•
SFK				•					•			•	•
SMTSSS				•					•				•
SMTSK				•					•				•
Part Number Codes For Finishes								ZI	ET	CN			

- (1) For plated studs, Class 2A/6g, the maximum major and pitch diameter, after plating, may equal basic sizes and can be gauged to Class 3A/6h, per ASME B1.1 Section 7, Paragraph 2 and ASME B1.13M, Section 8, Paragraph 8.2.
- (2) See PEM Technical Support section of our web site for related plating standards and specifications.
- (3) HRB - Hardness Rockwell "B" Scale. HB - Hardness Brinell.
- (4) Optimal solderability life noted on packaging.
- (5) ABS cap on PSHP screw has a temperature limit of 200° F / 93° C.
- (6) The tin deposit on type SMTSOB meets the requirements of ASTM B545, Class A and although the copper and nickel barrier layers used under the tin do not strictly comply with ASTM B545 thickness requirements they have proven effective at preventing zinc migration and providing the specified solderable shelf life.



Get quote >>

Angic Global Solutions

1-888-872-0690 [www.angic.com](http://www.angic.com) 97

<https://www.AngicGlobal.com> Sales@AngicGlobal.com

# FASTENERS FOR USE WITH PC BOARDS

## INSTALLATION

### KF2™/KFS2™/KFE™/KFSE™/PFK™ FASTENERS

1. Prepare properly sized mounting hole in board.
2. Place fastener into the anvil hole and place the mounting hole over the shank of the fastener as shown in drawing.
3. With installation punch and anvil surfaces parallel, apply squeezing force until shoulder contacts the board.

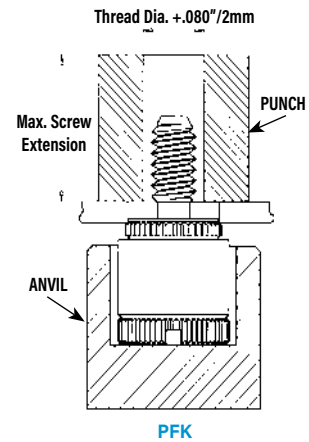

### PEMSERTER® Installation Tooling

Type	Thread Code	Anvil Part Number	Punch Part Number
KFE/KFSE	440/116 -4 to -8	975200846300	975200048
KFE/KFSE	440/116 -10 to -12	975200847300	
KFE/KFSE	440/116 -16 to -20	975200848300	
KFE/KFSE	440/116 -20 to -24	975200882300	
KFE/KFSE	M3 -3 to -6	975200846300	
KFE/KFSE	M3 -8 to -10	975200847300	
KFE/KFSE	M3 -12 to -14	975201223200	
KFE/KFSE	M3 -14 to -16	975200848300	
KFE/KFSE	632/143 -4 to -8	975200849300	
KFE/KFSE	632/143 -10 to -12	975200850300	
KFE/KFSE	632/143 -16 to -20	975200851300	
KFE/KFSE	632/143 -22 to -24	975200883300	
KFE/KFSE	632/143 -28 to -32	975200884300	
KFE/KFSE	3.6 -3 to -6	975200849300	975200048
KFE/KFSE	3.6 -8 to -10	975200850300	
KFE/KFSE	3.6 -12 to -16	975200851300	
KFE/KFSE	4.2 -2	975201216300	
KFE/KFSE	4.2 -3 to -6	975201217300	
KFE/KFSE	4.2 -8 to -10	975201218300	
KFE/KFSE	4.2 -12 to -14	975201220300	
KFE/KFSE	4.2 -14 to -16	975201219300	

### PEMSERTER® Installation Tooling

Type	Thread Code	Anvil Part Number	Punch Part Number
PFK	440/M3	975200026	975200060
PFK	632	975200027	975200061

### PEMSERTER® Installation Tooling

Type	Thread Code	Anvil Part Number	Punch Part Number
KF2/KFS2	080	8015899	975200048
KF2/KFS2	256/440/M2/M2.5/M3	975200904300	
KF2/KFS2	632/M3.5	975200035	
KF2/KFS2	832/M4	975200037	
KF2/KFS2	032/M5	975200905300	

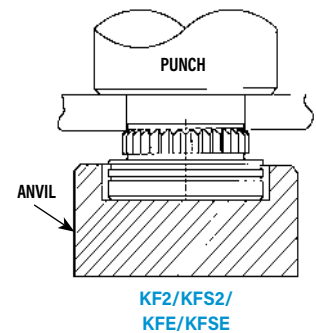

### KSSB™/KFH™ FASTENERS

1. Prepare properly sized mounting hole in board.
2. Place fastener into mounting hole as shown.
3. With installation punch and anvil surfaces parallel, apply squeezing force until head contacts the board.

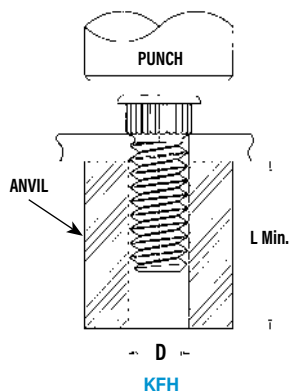

### PEMSERTER® Installation Tooling

Part Number	D +.003" -.000"	Punch Part No.	Anvil Part No.*
KFH-440-L	.113"	975200048	970200006300
KFH-632-L	.140"		970200007300
KFH-832-L	.166"		970200008300
KFH-032-L	.191"		970200009300

Part Number	D +0.08mm	Punch Part No.	Anvil Part No.*
KFH-M3-L	3.1mm	975200048	970200229300
KFH-M4-L	4.1mm		970200019300
KFH-M5-L	5.1mm		970200008300

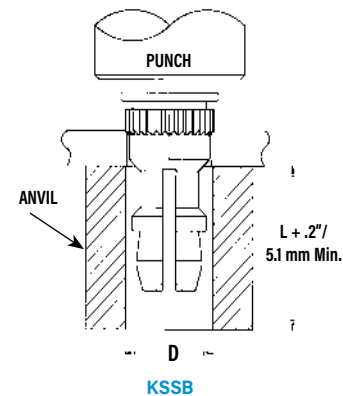

### PEMSERTER® Installation Tooling

Part Number	D +.003" -.000"/ +0.08mm	Punch Part No.	Anvil for material .050" / 1.27mm to .065" / 1.65mm	Anvil for material greater than .065" / 1.65mm
KSSB-156-L	.216"	975200048	8022167	970200015300
KSSB-4mm-L	5.49mm			

# FASTENERS FOR USE WITH PC BOARDS

## KFB3™ FASTENERS

1. Prepare properly sized mounting hole in board.
2. Place fastener into the anvil hole and place the mounting hole over the shank of the fastener as shown in diagram to the left.
3. Using a punch flaring tool and a recessed anvil, apply squeezing force until the shoulder of the fastener contacts the board. As the fastener seats itself in the proper position, the punch tool will flare the extended portion of the shank outward to complete the installation. The combination of broaching and flaring provides high pushout performance.

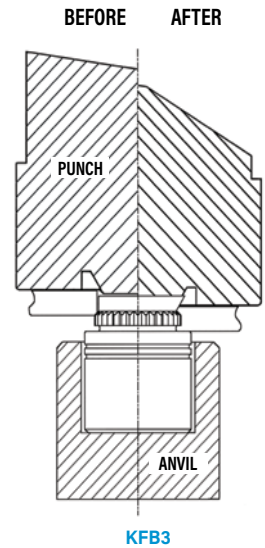

## PEMSERTER® Installation Tooling<sup>(1)</sup>

Thread Code	Length Code	Anvil	Punch (Flaring Tool)
#4-40	-2	975201213300	975201231400
#4-40	-4 to -8	975200846300	
#4-40	-10 to -12	975200847300	
#4-40	-16 to -20	975200848300	
#4-40	-20 to -24	975200882300	
#6-32	-2	975201215300	975201232400
#6-32	-4 to -8	975200849300	
#6-32	-10 to -12	975200850300	
#6-32	-16 to -20	975200851300	
#6-32	-22 to -24	975200883300	
#6-32	-28 to -32	975200884300	

Thread Code	Length Code	Anvil	Punch (Flaring Tool)
M3	-2	975201213300	975201231400
M3	-3 to -6	975200846300	
M3	-8 to -10	975200847300	
M3	-12 to -14	975201222300	
M3	-14 to -16	975200848300	
M4	-2	975201216300	975201221400
M4	-3 to -6	975201217300	
M4	-8 to -10	975201218300	
M4	-12 to -14	975201220300	
M4	-14 to -16	975201219300	

(1) PennEngineering manufactures and stocks the installation tooling for KFB3 fasteners.

## SFK™ FASTENERS

- Step 1.** Prepare properly sized mounting hole in both panels.
- Step 2.** Using only Panel 1, with the punch and anvil surfaces parallel, apply squeezing force until the fastener is flush with the top of Panel 1.
- Step 3.** Place Panel 2 over fastener and apply squeezing force.

## PEMSERTER® Installation Tooling<sup>(1)</sup>

Size	C ±0.13/±.003 (mm) / (in.)	Punch Part No.	Anvil Part No.*
SFK-3	3.05 / .120	975200048	970200229300
SFK-5	5.05 / .199	975200048	970200020300

\* Part number for anvil used in Step 2

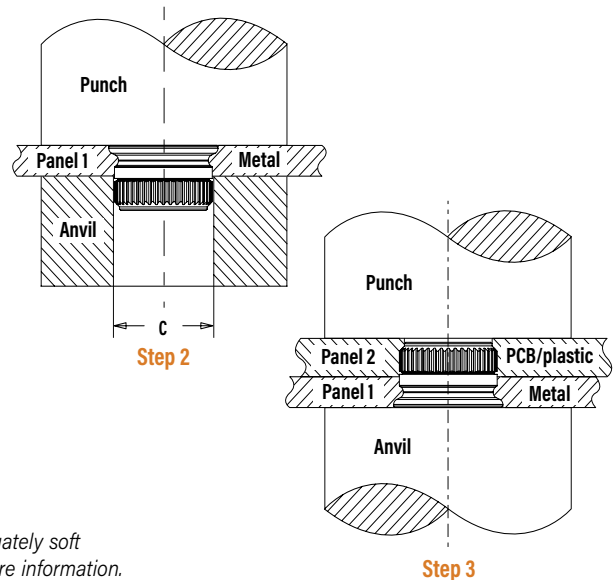

**NOTE:** Fastener can be installed in both sheets at once when metal panel is adequately soft compared to the non-metal panel. E-mail [techsupport@pemnet.com](mailto:techsupport@pemnet.com) for more information.

### INSTALLATION NOTES

- For best results we recommend using a Haeger® or PEMSERTER® machine for installation of PEM® self-clinching fasteners. Please check our website for more information.
- Visit the Animation Library on our website to view the installation process [for select products](#).



Get quote >>

Angic Global Solutions

1-888-872-0690 [www.angic.com](http://www.angic.com) 99

<https://www.AngicGlobal.com> Sales@AngicGlobal.com

# FASTENERS FOR USE WITH PC BOARDS

## INSTALLATION

### SMTSO™ NUTS AND STANDOFFS

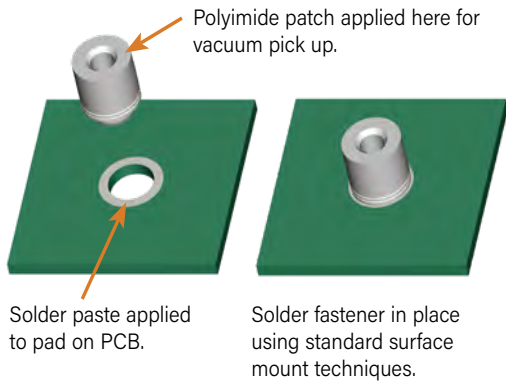

### SMTRA™ R'ANGLE® FASTENERS

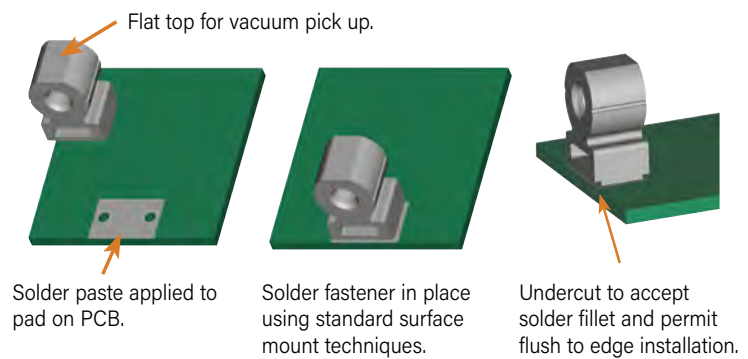

### SMTPF™ CAPTIVE PANEL SCREWS

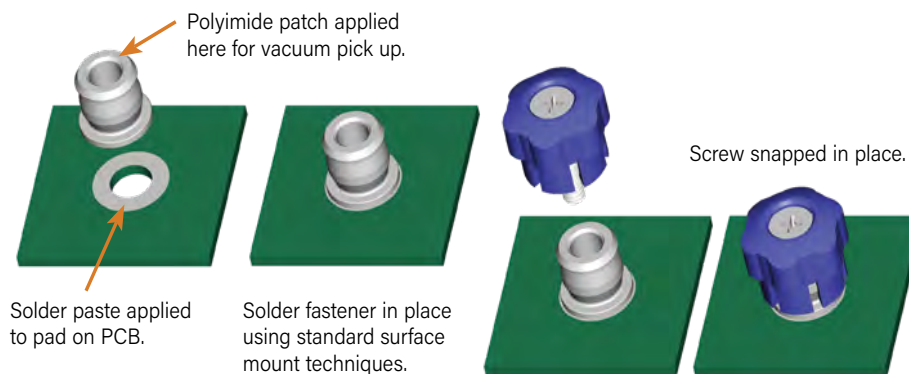

### SMTPLSM™ CAPTIVE PANEL SCREWS

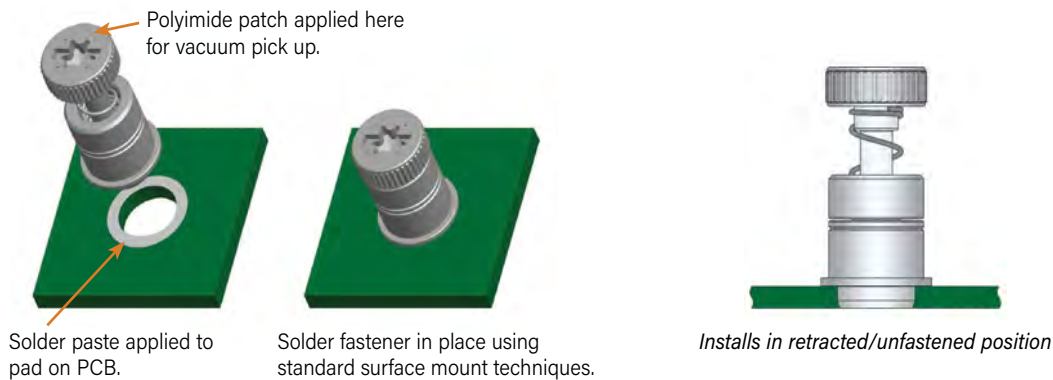

### SMTSS™ STANDOFFS

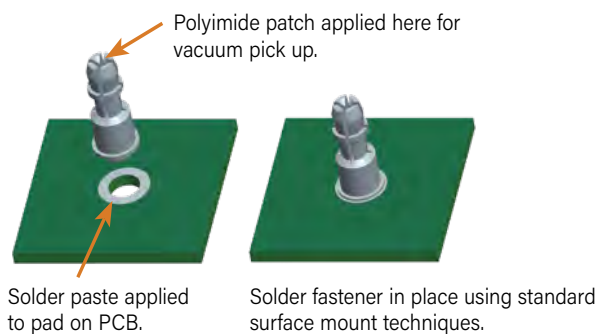

### SMTSK™ STANDOFFS

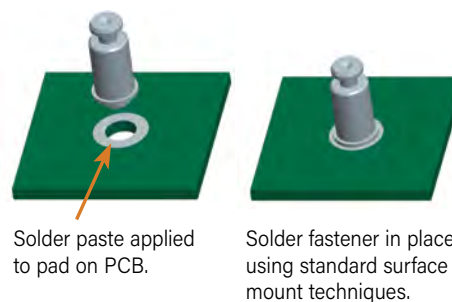

# FASTENERS FOR USE WITH PC BOARDS

## PERFORMANCE DATA<sup>(1)</sup>

### KF2™/KFS2™/KFE™/KFSE™/KFB3™/KFH™/PFK™ BROACHING AND BROACH/FLARE MOUNT FASTENERS

UNIFIED	Type	Thread Code	Max. Nut Tightening Torque (in. lbs.)	Test Sheet Thickness & Test Sheet Material	Installation (lbs.)	Pushout <sup>(2)</sup> (lbs.)	Torque-out (in. lbs.)
	KF2, KFS2 KFE, KFSE	256	(3)	.060" FR-4 Panel	400	60	6
		440	(3)	.060" FR-4 Panel	400	65	15
		632	(3)	.060" FR-4 Panel	500	80	30
		832	(3)	.060" FR-4 Panel	700	95	35
		032	(3)	.060" FR-4 Panel	700	100	40
	KFB3	440	(3)	.060" FR-4 Panel	1,000	140	18
		632	(3)	.060" FR-4 Panel	1,500	170	28
	KFH	440	4	.060" FR-4 Panel	400	65	7
		632	8	.060" FR-4 Panel	400	70	11
832		15	.060" FR-4 Panel	400	80	16	
032		18	.060" FR-4 Panel	400	90	17	
PFK	440	(3)	.060" FR-4 Panel	250	55	(3)	
	632	(3)	.060" FR-4 Panel	400	60	(3)	

METRIC	Type	Thread Code	Max. Nut Tightening Torque (N·m)	Test Sheet Thickness & Test Sheet Material	Installation (kN)	Pushout <sup>(2)</sup> (N)	Torque-out (N·m)
	KF2, KFS2 KFE, KFSE	M2	(3)	1.5 mm FR-4 Panel	2.2	267	0.68
		M3	(3)	1.5 mm FR-4 Panel	2.2	290	1.7
		M4	(3)	1.5 mm FR-4 Panel	2.2	420	3.4
		M5	(3)	1.5 mm FR-4 Panel	2.9	440	4.5
	KFB3	M3	(3)	1.5 mm FR-4 Panel	4.4	560	2.03
		M4	(3)	1.5 mm FR-4 Panel	6	680	3.2
	KFH	M3	0.45	1.5 mm FR-4 Panel	1.8	285	0.79
		M4	1.6	1.5 mm FR-4 Panel	1.8	355	1.8
		M5	2.1	1.5 mm FR-4 Panel	1.8	400	1.92
PFK	M3	(3)	1.5 mm FR-4 Panel	1.1	245	(3)	

### KSSB™ BROACHING SNAP-TOP® STANDOFFS

UNIFIED	Type	Panel 1 (.060" FR-4 Fiberglass) <sup>(4)</sup>		Panel 2 (Removable) <sup>(4)</sup>		
		Installation (lbs.)	Pushout (lbs.)	Max. First On Force (lbs.)	Min. First Off Force (lbs.)	Min. 15th Off Force (lbs.)
	KSSB	500	110	13	3.0	1.0

METRIC	Type	Panel 1 (1.5 mm FR-4 Fiberglass) <sup>(4)</sup>		Panel 2 (Removable) <sup>(4)</sup>		
		Installation (kN)	Pushout (N)	Max. First On Force (N)	Min. First Off Force (N)	Min. 15th Off Force (N)
	KSSB	2.2	484	57.7	13.3	4.4

(1) Published installation forces are for general reference. Actual set-up and confirmation of complete installation should be made by observing proper seating of fastener as described in the installation steps. Other performance values reported are averages when all proper installation parameters and procedures are followed. Variations in mounting hole size, sheet material, and installation procedure may affect performance. Performance testing this product in your application is recommended. We will be happy to provide technical assistance and/or samples for this purpose.

(2) These are typical values for parts installed in drilled mounting holes. Punched mounting holes yield values approximately 15% less.

(3) Not applicable.

(4) See Application Data drawing on page 91.



Get quote »

Angic Global Solutions

1-888-872-0690 [www.AngicGlobal.com](http://www.AngicGlobal.com) 101

<https://www.AngicGlobal.com> Sales@AngicGlobal.com

# FASTENERS FOR USE WITH PC BOARDS

## SFK™ SpotFast® CLINCH/BROACH MOUNT FASTENERS

Type and Size	Thick-ness Code	Installation into Panel 1		Installation into Panel 2		Pushout of Panel 2 <sup>(3)</sup>	
		Cold-rolled Steel		FR-4 Fiberglass		N      lbs.	
		kN	lbs.	kN	lbs.		
SFK-3	0.8	6.2	1400	1.8	400	200	45
SFK-3	1.0	8	1800	1.8	400	200	45
SFK-3	1.2	8.9	2000	1.8	400	200	45
SFK-3	1.6	10.2	2300	1.8	400	200	45
SFK-5	0.8	11.1	2500	1.8	400	400	90
SFK-5	1.0	13.5	3000	1.8	400	400	90
SFK-5	1.2	15.6	3500	1.8	400	400	90
SFK-5	1.6	17.8	4000	1.8	400	400	90

## SMTSO™/SMTSOB™ FASTENERS<sup>(1)(2)</sup>

Type	Thread/Thru-hole Code	Test Sheet Material - .062" Single Layer FR-4				Rated Current Amps <sup>(6)</sup>
		Pushout (lbs.)	Pushout (N)	Torque-out (in. lbs.)	Torque-out (N-m)	
SMTSO	080	85.1	378.7	4.94	0.56	11
SMTSOB						—
SMTSO	256	56.5	251	8.56	1	25
SMTSOB						40
SMTSO	440	56.5	251	8.56	1	22
SMTSOB						36
SMTSO	632	93.5	416	13.83	1.6	34
SMTSOB						55
SMTSO	832	151.1	672	26.96	3	47
SMTSOB						76
SMTSO	116	—	—	—	—	22
SMTSOB						37
SMTSO	143	—	—	—	—	33
SMTSOB						55
SMTSO	M1	85.1	378.7	4.94	0.56	11
SMTSOB						—
SMTSO	M1.2	85.1	378.7	4.94	0.56	10
SMTSOB						—
SMTSO	M1.4	85.1	378.7	4.94	0.56	10
SMTSOB						—
SMTSO	M1.6	85.1	378.7	4.94	0.56	10
SMTSOB						—
SMTSO	M3	56.5	251	8.56	1	22
SMTSOB						36
SMTSO	M3.5	93.5	416	13.83	1.6	34
SMTSOB						55
SMTSO	M4	151.1	672	26.96	3	47
SMTSOB						76
SMTSO	3.1	—	—	—	—	22
SMTSOB						36
SMTSO	3.6	—	—	—	—	33
SMTSOB						55
SMTSO	4.2	—	—	—	—	46
SMTSOB						75

## TESTING CONDITIONS FOR SURFACE MOUNTED FASTENERS

<b>Oven</b>	Quad ZCR convection oven w/ 4 zones	<b>Spokes</b>	2 Spoke Pattern
<b>High Temp</b>	473 °F / 245 °C	<b>Paste</b>	Amtech NC559LF Sn96.5/3.0Ag/0.5Cu (SAC305) (SMTSO, SMTRA, SMTPR)
<b>Board Finish</b>	62% Sn, 38% Pb		Alpha CVP-390 Sn96.5/3.0Ag/0.5Cu (SAC305) (SMTPFLSM, SMTSS, SMTSK)
<b>Screen Printer</b>	Ragin Manual Printer	<b>Stencil</b>	.0067" / 0.17 mm thick (SMTSO, SMTRA, SMTPR, SMTSS, SMTSK)
<b>Vias</b>	None		.005" / 0.13 mm thick (SMTPFLSM)

- (1) With lead-free paste. Average values of 30 test points. The data presented here is for general comparison purposes only. Actual performance is dependent upon application variables. We will be happy to provide samples for you to install. If required, we can also test your installed hardware and provide you with the performance data specific to your application.
- (2) Further testing details can be found in our website's literature section.
- (3) In most applications, pullout strength of the SFK fastener in Panel 1 exceeds pushout strength of Panel 2.
- (4) Torque values shown will produce a preload of 70% minimum tensile with a nut factor "k" equal to .1.
- (5) Failure occurred at the solder joint. Screw retention strength is greater than the retainer.
- (6) The maximum carrying current for each of the above fasteners is calculated based on a heat transfer coefficient of 20 W/m<sup>2</sup> °K and a maximum temperature rise of 15°C / 27°F above ambient.

## SMTSS™ ReelFast® SNAP-TOP® STANDOFFS<sup>(1)(2)</sup>

Type, Material and Size	Panel 1 (Bottom)		Panel 2 (Top)
	Test Sheet Material	Pushout	Max. Snap-on Force
	SMTSS-156	.062" Single Layer FR-4	113 lbs.
SMTSS-4MM	1.58 mm Single Layer FR-4	500 N	89 N

## SMTSK™ KEYHOLE® STANDOFFS<sup>(1)(2)</sup>

Type and Size	Panel 1 (Bottom)	
	Test Sheet Material	Pushout
	SMTSK-6060	.062" Single Layer FR-4
SMTSK-61.5	1.58 mm Single Layer FR-4	500 N

## SMTRA™ R'ANGLE® FASTENERS<sup>(1)(2)</sup>

UNIFIED	Part Number	Test Sheet Material - .062" Single Layer FR-4	
		Pushout (lbs.)	Side Load (lbs.)
	SMTRA256-8-6	51.7	7.1
SMTRA440-9-6	89.5	10.8	
SMTRA632-10-8	110.3	8.4	
SMTRA832-12-9	137.2	21.2	

METRIC	Part Number	Test Sheet Material - 1.58 mm Single Layer FR-4	
		Pushout (N)	Side Load (N)
	SMTRAM2-6-5	418.2	56.8
SMTRAM25-6-5	216.5	36.9	
SMTRAM3-7-5	257.6	41.3	
SMTRAM4-9-7	369.3	73.3	

## SMTPFLSM™ FASTENERS<sup>(1)</sup>

UNIFIED	Type and Thread Size	Min. Tensile Strength (lbs.)	Rec. Tightening Torque (in. lbs.) <sup>(4)</sup>	Test Sheet Material
				.060" P.C. Board Pull-off (lbs.) <sup>(5)</sup>
	SMTPFLSM-440	556	4.4	100
SMTPFLSM-632	724	7.0	105	

METRIC	Type and Thread Size	Min. Tensile Strength (N)	Rec. Tightening Torque (N-m) <sup>(4)</sup>	Test Sheet Material
				1.5 mm P.C. Board Pull-off (N) <sup>(5)</sup>
	SMTPFLSM-M3	2900	0.61	445
SMTPFLSM-M3.5	3269	0.8	465	

## SMTPR™ RETAINERS<sup>(1)</sup>

Part Number	Test Sheet Material - .062" Single Layer FR-4	
	Pushout (lbs.)	Pushout (N)
SMTPR-6-1ET	161.4	718

# FASTENERS FOR USE WITH PC BOARDS

## SMTSO™ REFLOW CURVE

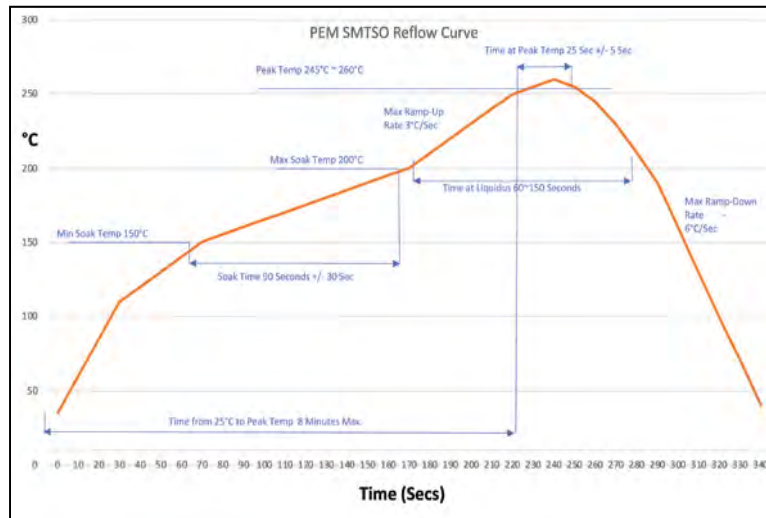

## OTHER FASTENERS FOR CONSIDERATION TO USE WITH PC BOARDS

### PF11MW™ FLOATING CAPTIVE PANEL SCREWS

(See PEM® Bulletin PF)

Unique flare mount feature allow fasteners to “float” in mounting hole.

- Compensates for mating thread misalignment.
- Installs into any panel material.
- Appropriate for close center-line-to-edge applications.
- Color coded knobs available.



Can install into PC Board, plastic or metal

### PF11MF™ FLARE-MOUNTED CAPTIVE PANEL SCREWS

(See PEM® Bulletin PF)

- Appropriate for close centerline-to-edge applications.
- Doesn't require high installation force.
- Installs into any panel material.
- Installs flush on back side of panel.
- Color coded knobs available.



Can install into PC Board, plastic or metal

### SGPC™ SWAGING COLLAR STUDS

(See PEM® Bulletin FH)

- Can be installed into most materials, including stainless steel and rigid non-metallic panels.
- Can be used to attach dissimilar materials.
- Can accommodate multiple panels as long as the total thickness does not exceed the maximum sheet thickness.
- Appropriate for close center-line-to-edge applications.



Can install into PC Board, plastic or metal

### SOAG™/SOSG™ GROUNDING STANDOFFS

(See PEM® Bulletin SO)

- Designed for clinching into steel or aluminum chassis.
- “Gripping teeth” on opposite side of standoff makes firm electrical contact with mating PC Board.



PC Board plastic or metal

Metal

### SKC™ KEYHOLE® STANDOFFS

(See PEM® Bulletin SK)

- Clinch feature mounts fastener permanently into metal sheet.
- Allows for quick attachment and detachment of PC Board.
- Head is flush or sub-flush in metal sheet.
- Makes horizontal or vertical component mounting possible.



PC Board plastic or metal

Metal

### SSA™/SSC™/SSS™ SNAP-TOP® STANDOFFS

(See PEM® Bulletin SSA)

- Spring action holds PC Boards and subassemblies securely, while allowing for quick removal.
- Screws and other threaded hardware are eliminated.



PC Board plastic or metal

Metal



Get quote >>

Angic Global Solutions

1-888-872-0690

et.com 103

<https://www.AngicGlobal.com> Sales@AngicGlobal.com



PEM® self-clinching locknuts prevent mating hardware from loosening.



**LN™**

**SELF-LOCKING  
FASTENERS**

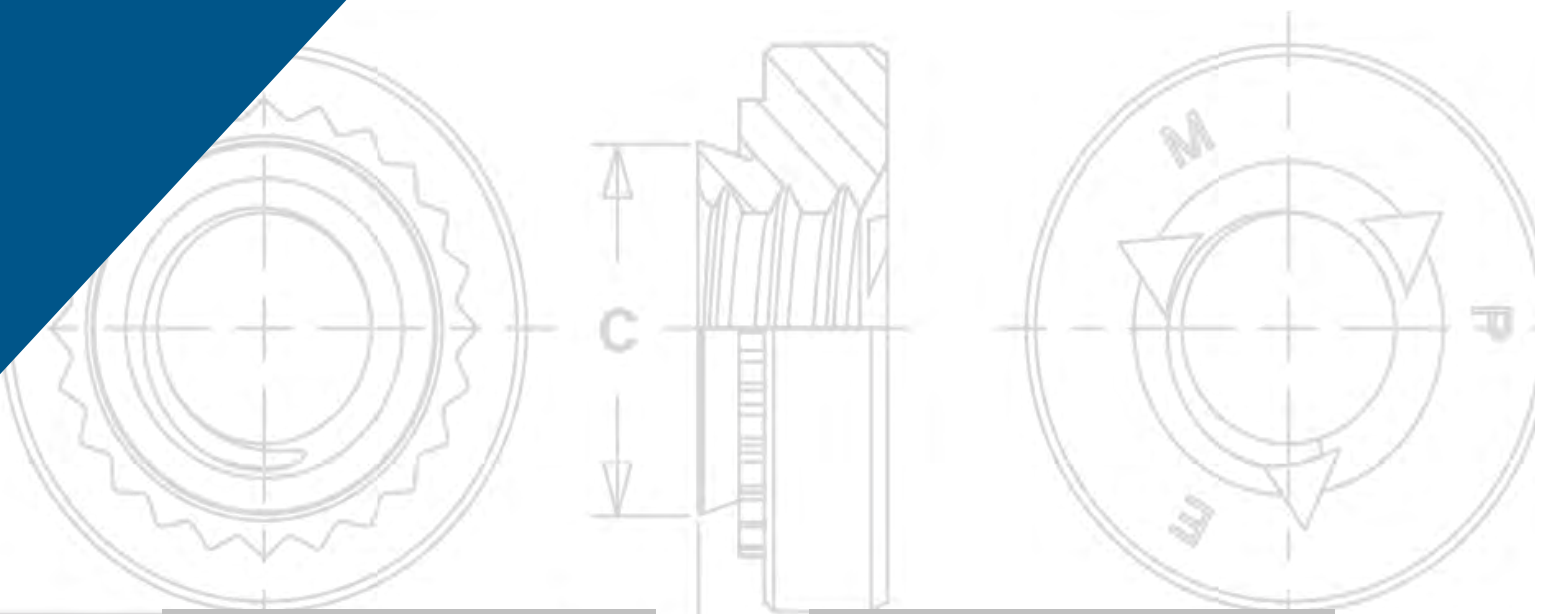

Get quote >>

Angic Global Solutions

1-888-872-0690

<https://www.AngicGlobal.com> [Sales@AngicGlobal.com](mailto:Sales@AngicGlobal.com)

# SELF-LOCKING FASTENERS

## PEM® SELF-CLINCHING LOCKNUTS PREVENT MATING HARDWARE FROM LOOSENING

PEM® self-clinching locknuts provide ideal solutions to prevent mating hardware from loosening in service due to vibration or other application-related factors. This family of fasteners includes a variety of types and different locking-feature styles to satisfy a wide range of applications. Their use can save time and money compared with alternative chemical locking methods or patches.

### ABOUT LOCKING THREADS

PEM® locknuts include two locking designs:

**1) PREVAILING TORQUE** (CFN™, FE™, FEO™, UL™, LAS™, LAC™, LA4™, LK™, LKS™, LKA™, PL™, PLC™ and SL™ locknuts) – a design feature of the lock nut produces friction between threads of mated components thereby increasing the force needed to tighten as well as loosen the nut. Prevailing torque locknuts provide essentially the same torque value regardless of the amount of axial load applied.

Available in two types:

▪ **All metal –**

All PEM metal prevailing torque type locknuts achieve their prevailing torque by altering the shape of the nut in some way - most commonly by distorting the threads of the nut, which then grips the mating part during tightening. Screws for use with PEM prevailing torque locknuts should be Class 3A/4h fit or no smaller than Class 2A/6g.

Available in three styles:

- **Elliptically squeezed threads** (UL™, FE™, FEO™, LAC™, LAS™ and LA4™ locknuts) – the thread barrel is slightly deformed into an elliptical shape.
- **Flexing jaws** (LK™, LKS™ and LKA™ locknuts) – the thread barrel is vertically slit and then the two sections are squeezed together.
- **One or two deformed threads** (SL™ locknuts) – the last threads on the head side of the nut are deformed.

Typically prevailing torque locknuts utilizing a metal locking feature are treated with a dry film lubricant coating to afford some level of lubricity to reduce damage to the threads from repeated installation and removal of the screw and reduce required tightening torque. Care should be taken to be sure that lubricant is not removed in any post installed finishing operations.

▪ **Nylon insert**

The PL™, PLC™ and CFN™ locknuts use a plastic insert, typically made from nylon to generate the torque resistance. A nylon ring is attached to the self-clinching body on the screw exit side with an ID approximately at the screw pitch diameter. As the screw enters this ring, there is interference at the major diameter generating a prevailing torque. The major advantage of this locking method is the greatly reduced chance of any conductive debris being generated by repeated installation and removal of the screw.

**2) FREE-RUNNING** (PEM RT® locknuts) – a nut that requires tightening against a bearing surface in order for the locking mechanism to function. If the tightening force (clamp load) is removed for any reason, these nuts no longer provide any torsional resistance to rotation. The **modified thread formation** allows mating screws to spin freely during the attachment process until clamp load is induced during the screw-tightening process.

PEM free-running locknuts will accept a maximum material 6g/2A screw.



Fastener drawings and models are available at [www.pemnet.com](http://www.pemnet.com)









Get quote »

Angic Global Solutions

1-888-872-0690 [www.angic.com](http://www.angic.com) 105

<https://www.AngicGlobal.com> Sales@AngicGlobal.com

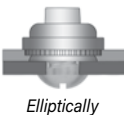
# SELF-LOCKING FASTENERS

<p><b>CFN™</b> broaching fasteners are available for thinner sheet, close-to-edge applications. The nylon locking element provides prevailing torque to eliminate loosening of mating threaded hardware - <b>PAGE 107</b></p>	 <p>Nylon Insert</p>	<p><b>PL™/PLC™</b> PEMHEX® nuts with a nylon hexagonal element provide a locking option for applications where a metal on metal locking feature is not desired - <b>PAGE 111</b></p>	 <p>Nylon Insert</p>
<p><b>FE™/FEO™/UL™</b> miniature locking nuts, provide a smaller body for tight space, lightweight applications - <b>PAGE 108</b></p>	 <p>Elliptically Squeezed Threads</p>	<p><b>SL™</b> locknuts offer a cost effective TRI-DENT® locking feature and effective prevailing locking torque - <b>PAGE 112</b></p>	 <p>Deformed Threads</p>
<p><b>LAS™/LAC™/LA4™</b> nuts with self-locking, floating threads that permit up to .030"/0.76 mm adjustment for mating hole misalignment - <b>PAGE 109</b></p>	 <p>Elliptically Squeezed Threads</p>	<p><b>PEM RT®</b> locknuts are free-running until clamp load is induced. A modified thread angle on the loaded flank provides the vibration resistant locking feature- <b>PAGE 113</b></p>	<p><b>NEW</b></p>  <p>Free-running Threads</p>
<p><b>LK™/LKS™/LKA™</b> nuts have a rugged PEMFLEX® self-locking feature which meets demanding locking performance requirements - <b>PAGE 110</b></p>	 <p>Flexing Jaws</p>	<p><b>Material and finish specifications - PAGES 114</b></p> <p><b>Installation - PAGES 115 - 118</b></p> <p><b>Performance data - PAGES 119 - 123</b></p>	

## LOCKING NUT SELECTOR GUIDE

PEM Locking Nut	Page No.	Locking Performance Cycles	Application Features				Locking Performance Temperature Limit	Non-metal on Metal Locking Feature	Locking Style	Covered by <sup>(1)</sup>	
			High Clamp Strength	Floating Threads	Light Weight	Close-to-edge Applications				M45938/7	M45938/11
CFN	107	1	▪			▪	(6)	▪	Nylon Insert		
FE	108	15 <sup>(3)</sup>			▪	▪	(7)		Elliptically Squeezed	▪	
FEO	108	15 <sup>(3)</sup>			▪	▪	(7)		Elliptically Squeezed	▪	
UL	108	5 <sup>(4)</sup>			▪	▪	(7)		Elliptically Squeezed	▪	
LAS	109	15 <sup>(3)</sup>	▪	▪			(7)		Elliptically Squeezed		▪
LAC	109	15 <sup>(3)</sup>	▪	▪			(7)		Elliptically Squeezed		▪
LA4 <sup>(2)</sup>	109	15 <sup>(3)</sup>	▪	▪			(7)		Elliptically Squeezed		▪
LK	110	15 <sup>(3)</sup>	▪				(7)		Flexing Jaws		
LKS	110	15 <sup>(3)</sup>	▪				(7)		Flexing Jaws		
LKA	110	15 <sup>(3)</sup>	▪				(9)		Flexing Jaws		
PL	111	15 <sup>(3)</sup>					(6)	▪	Nylon Insert		
PLC	111	15 <sup>(3)</sup>					(6)	▪	Nylon Insert		
SL	112	3	▪				(8)		Deformed Threads		
PEM RT®	113	(5)	▪				(8)		Free-running Threads		

- (1) To meet national aerospace standards and to obtain testing documentation, product must be ordered using appropriate NASM45938 part number. Check our web site for a complete Military Specification and National Aerospace Standards Reference Guide (Bulletin NASM).
- (2) Specifically designed to be installed into stainless steel sheets.
- (3) See page 125 for information on NASM25027 as applied to PEM self-clinching, self-locking nuts.
- (4) Meets torque requirements for NASM25027 through five cycles.
- (5) Locking performance is not affected by the number of on/off cycles.
- (6) Nylon locking element temperature limit is 250° F / 120° C.
- (7) Dry film lubricant rated for use up to 400° F / 204° C.
- (8) The fastening strength of the locknut is maintained up to 800° F / 426° C. Temperatures above 300° F / 149° C will dehydrate the conversion coating.
- (9) Aluminum material temperature limit is 250° F / 120° C.

# SELF-LOCKING FASTENERS

## CFN™ BROACHING LOCKNUT



- For thinner sheets, close-to-edge applications.
- Prevailing torque locking element provides torque to eliminate loosening of mating threaded hardware.

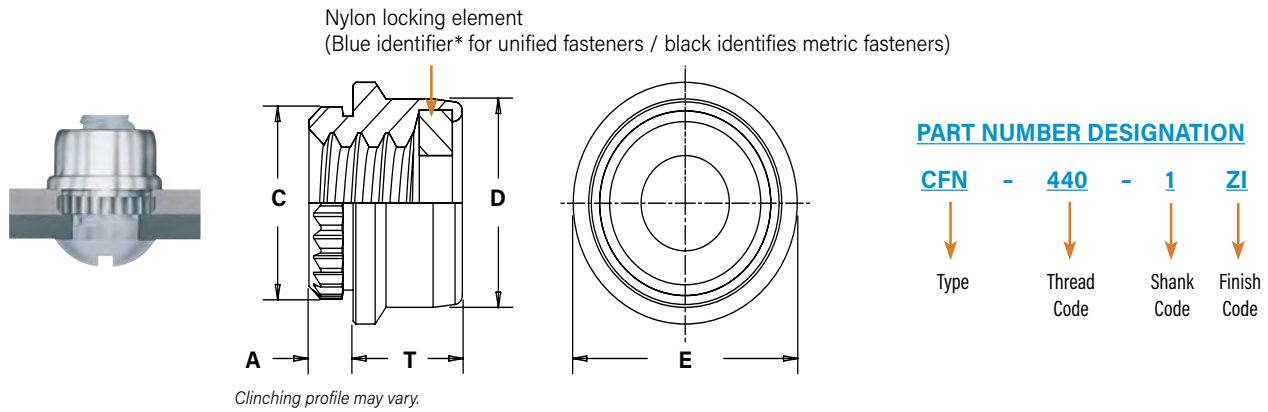

All dimensions are in inches.

UNIFIED	Thread Size	Type	Thread Code	Shank Code	A (Shank) ±.003	Min. Sheet Thickness	Hole Size In Sheet +.003 -.000	C ±.002	D ±.004	E +.001 -.004	T Max.	Min. Dist. Hole to Edge
	.112-40 (#4-40)	CFN	440	1	.040	.043	.152	.162	.175	.203	.104	.115

All dimensions are in millimeters.

METRIC	Thread Size x Pitch	Type	Thread Code	Shank Code	A (Shank) ±0.08	Min. Sheet Thickness	Hole Size In Sheet +0.08	C ±0.05	D ±0.1	E +0.03 -0.1	T Max.	Min. Dist. Hole to Edge
	M3 x 0.5	CFN	M3	1	1.02	1.1	3.86	4.11	4.45	5.16	2.65	2.93

\*PEM Trademark.



Get quote »

Angic Global Solutions

1-888-872-0690 [www.angic.com](http://www.angic.com) 107

<https://www.AngicGlobal.com> Sales@AngicGlobal.com

# SELF-LOCKING FASTENERS

## FE™/FEO™/UL™ LOCKNUTS



- Strong, knurled collar guarantees against rotation of the fastener in the sheet.
- The torque-out resistance of the embedded knurl greatly exceeds the torque that can be exerted by the self-locking feature.

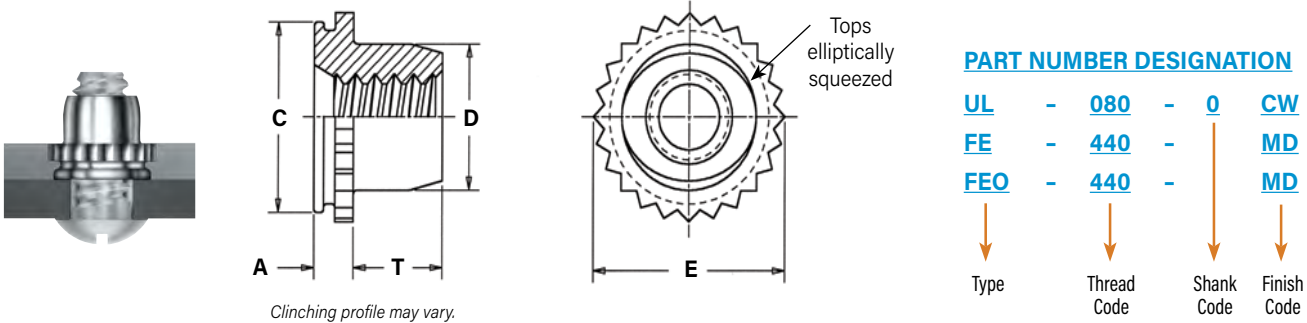

Clinching profile may vary.

All dimensions are in inches.

UNIFIED	Thread Size	Type	Thread Code	Shank Code (1)	A (Shank) Max.	Sheet Thickness (2)	Hole Size In Sheet +.003 - .000	C +.000 - .005	D Max.	E ±.005	T +.015 - .000	Min. Dist. Hole to Edge	Max. Hole In Attached Parts
	.060-80 (#0-80)	UL	080	0	.020	.019 - .022	.110	.1095	.076	.125	.050	.09	.080
	.073-64 (#1-64)	UL	164	0	.020	.019 - .022	.110	.1095	.090	.125	.050	.09	.093
	.086-56 (#2-56)	UL	256	0	.020	.019 - .022	.144	.1435	.106	.160	.065	.11	.106
				1	.031	.030 - .036							
	.112-40 (#4-40)	FEO	440		.040	.039 - .045	.172	.171	.145	.192	.065	.14	.132
		FE		.060	.059 - .070								
	.138-32 (#6-32)	FEO	632		.040	.039 - .045	.213	.212	.180	.244	.075	.17	.158
		FE		.060	.059 - .070								
	.164-32 (#8-32)	FEO	832		.040	.039 - .045	.290	.289	.215	.322	.090	.20	.184
		FE		.060	.059 - .070								
	.190-32 (#10-32)	FEO	032		.040	.039 - .045	.290	.289	.245	.322	.110	.20	.210
		FE		.060	.059 - .070								
1/4-20	FE	0420		.060	.059 - .070	.344	.343	.318	.384	.120	.28	.270	
1/4-28		0428											

All dimensions are in millimeters.

METRIC	Thread Size x Pitch	Type	Thread Code	Shank Code (1)	A (Shank) Max.	Sheet Thickness (2)	Hole Size In Sheet +0.08	C -0.13	D Max.	E ±0.13	T +0.4	Min. Dist. Hole to Edge	Max. Hole In Attached Parts
	M2 x 0.4	UL	M2	1	0.76	0.76 - 0.91	3.61	3.6	2.5	4.07	1.65	2.8	2.5
	M3 x 0.5	FEO	M3		1.02	0.99 - 1.14	4.39	4.37	3.96	4.88	1.9	3.6	3.5
		FE		1.53	1.5 - 1.78								
	M4 x 0.7	FEO	M4		1.02	0.99 - 1.14	7.39	7.37	5.23	8.17	2.55	5.2	4.5
		FE		1.53	1.5 - 1.78								
	M5 x 0.8	FEO	M5		1.02	0.99 - 1.14	7.39	7.37	6.48	8.17	3.05	5.2	5.5
		FE		1.53	1.5 - 1.78								
M6 x 1	FE	M6		1.53	1.5 - 1.78	8.74	8.72	7.72	9.74	3.3	7.1	6.5	

(1) Shank code applicable only to UL fasteners.

(2) In applications between the sheet thicknesses for your thread size, see last paragraph of installation data on page 115. Knurled collar may fracture if fastener is used in sheets thicker than the specified range and the screw is tightened beyond maximum tightening torque.

# SELF-LOCKING FASTENERS

## LAS™/LAC™/LA4™ LOCKNUTS



- Provide load-bearing threads in thin sheets and permit a minimum of .030"/0.76 mm adjustment for mating hole misalignment.
- Extra strength and support in assembly is obtained by the threads of the floating nut extending into the retainer shank.
- Thread locking torque performance is equivalent to applicable NASM25027 specifications.
- LA4 floating fasteners are specifically designed to be installed into stainless steel sheets.

To meet national aerospace standards and to obtain testing documentation, product must be ordered to US NASM45938/11 specifications. Check our web site for a complete Military Specification and National Aerospace Standards Reference Guide (Bulletin NASM)

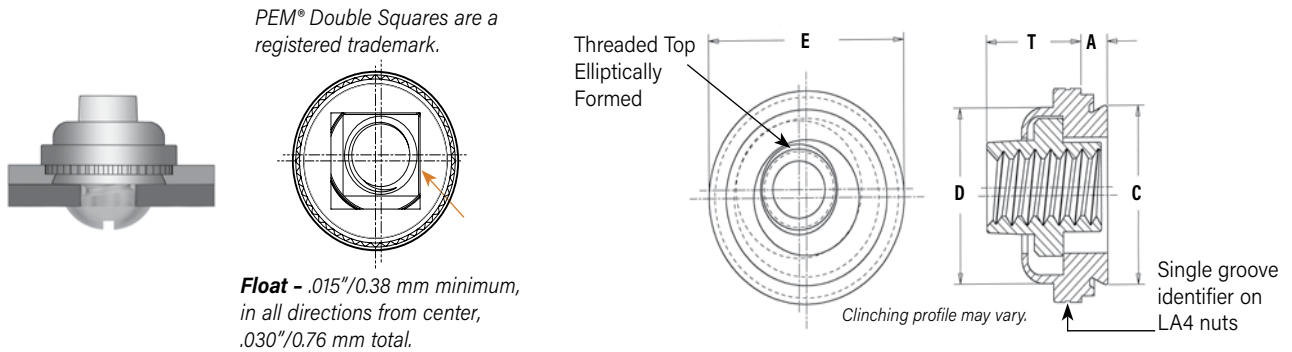

All dimensions are in inches.

UNIFIED	Thread Size	Type			Thread Code	Shank Code	A (shank) Max.	Min. Sheet Thickness	Hole Size in Sheet +.003 - .000	C Max.	D Max.	E ±.015	T <sub>2</sub> Max.	Min. Dist. Hole to Edge
		Fastener Material												
		Steel	300 Series Stainless	400 Series Stainless										
.112-40 (#4-40)	LAS	LAC	LA4	440	1	.038	.038	.290	.289	.290	.360	.190	.30	
					2 <sup>(1)</sup>	.054	.054							
.138-32 (#6-32)	LAS	LAC	LA4	632	1	.038	.038	.328	.327	.335	.390	.200	.32	
					2 <sup>(1)</sup>	.054	.054							
.164-32 (#8-32)	LAS	LAC	LA4	832	1	.038	.038	.368	.367	.365	.440	.210	.34	
					2 <sup>(1)</sup>	.054	.054							
.190-24 (#10-24)	LAS	LAC	LA4	024	1	.038	.038	.406	.405	.405	.470	.270	.36	
					2 <sup>(1)</sup>	.054	.054							
.190-32 (#10-32)	LAS	LAC	LA4	032	1	.038	.038	.406	.405	.405	.470	.270	.36	
					2 <sup>(1)</sup>	.054	.054							
.250-20 (1/4-20)	LAS	LAC	-	0420	2	.054	.054	.515	.514	.510	.600	.310	.42	
.250-28 (1/4-28)	LAS	LAC	-	0428	2	.054	.054	.515	.514	.510	.600	.310	.42	

All dimensions are in millimeters.

METRIC	Thread Size x Pitch	Type			Thread Code	Shank Code	A (shank) Max.	Min. Sheet Thickness	Hole Size in Sheet +0.08	C Max.	D Max.	E ±0.38	T <sub>2</sub> Max.	Min. Dist. Hole to Edge
		Fastener Material												
		Steel	300 Series Stainless	400 Series Stainless										
M3 x 0.5	LAS	LAC	LA4	M3	1	0.97	0.97	7.37	7.35	7.37	9.14	4.83	7.62	
					2 <sup>(1)</sup>	1.38	1.38							
M4 x 0.7	LAS	LAC	LA4	M4	1	0.97	0.97	9.35	9.33	9.28	11.18	5.34	8.64	
					2 <sup>(1)</sup>	1.38	1.38							
M5 x 0.8	LAS	LAC	LA4	M5	1	0.97	0.97	10.31	10.29	10.29	11.94	6.86	9.14	
					2 <sup>(1)</sup>	1.38	1.38							
M6 x 1	LAS	LAC	-	M6	2	1.38	1.38	13.08	13.06	12.96	15.24	7.88	10.67	

(1) This shank code is not available for LA4 nuts.

### PART NUMBER DESIGNATION

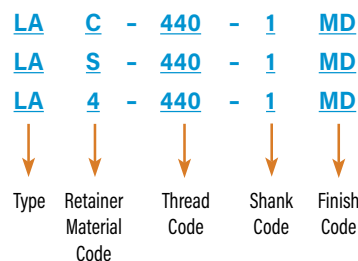

Get quote >>

Angic Global Solutions

1-888-872-0690 [www.angic.com](http://www.angic.com) 109

<https://www.AngicGlobal.com> Sales@AngicGlobal.com

# SELF-LOCKING FASTENERS

## LK™/LKS™/LKA™ PEMFLEX® LOCKNUTS



The PEM design utilizes two rugged, semicircular flexing jaws instead of several less-supported segments. The greater ruggedness and retention of this PEMFLEX® action prevents relaxation and loosening of the fastener in severe service. This design also protects the screw threads. Clearances obtained by only two interruptions of a full circumference, together with the spreading of the jaws by the entering screw, minimize the possibility of thread damage.

- Hex shoulder provides increased pull-through performance and a positive stop during installation.
- The flexing action of locking feature permits repeated use and effective locking torque.
- Thread locking performance of LK and LKS fasteners (with MD finish) and LKA fasteners (lubricated) are equivalent to applicable NASM25027 specifications.

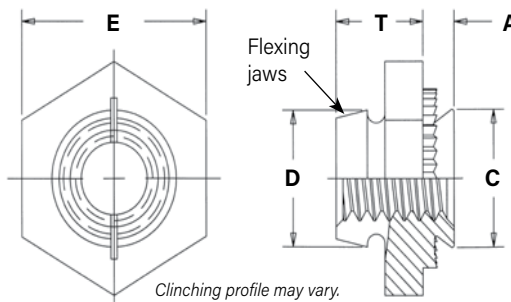
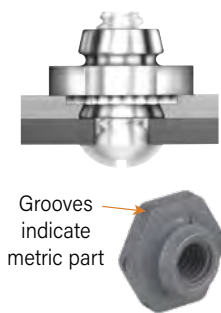

### PART NUMBER DESIGNATION

LK	-	632	-	1	MD
LK	S	632	-	1	MD
LK	A	632	-	1	
↓	↓	↓	↓	↓	↓
Type	Fastener Material Code	Thread Size Code	Shank Code	Finish Code	

All dimensions are in inches.

UNIFIED	Thread Size	Type			Thread Code	Shank Code	A (Shank) Max.	Min. Sheet Thickness	Hole Size In Sheet +.003 -.000	C Max.	D Max.	E Nom.	T ±.010	Min. Dist. Hole to Edge
		Fastener Material												
		Carbon Steel	Stainless Steel	Aluminum										
	.086-56 (#2-56)	LK	LKS	LKA	256	1	.038	.040	.172	.171	.165	.250	.135	.156
						2	.054	.056						
	.112-40 (#4-40)	LK	LKS	LKA	440	1	.038	.040	.187	.186	.185	.250	.135	.156
						2	.054	.056						
	.138-32 (#6-32)	LK	LKS	LKA	632	1	.038	.040	.219	.218	.220	.312	.145	.187
						2	.054	.056						
	.164-32 (#8-32)	LK	LKS	LKA	832	1	.038	.040	.266	.265	.250	.343	.175	.203
						2	.054	.056						
	.190-32 (#10-32)	LK	LKS	LKA	032	1	.038	.040	.312	.311	.285	.375	.205	.218
						2	.054	.056						

All dimensions are in millimeters.

METRIC	Thread Size x Pitch	Type			Thread Code	Shank Code	A (Shank) Max.	Min. Sheet Thickness	Hole Size In Sheet +0.08	C Max.	D Max.	E Nom.	T ±0.25	Min. Dist. Hole to Edge
		Fastener Material												
		Carbon Steel	Stainless Steel	Aluminum										
	M2.5 X 0.45	LK	LKS	LKA	M2.5	1	0.97	1	4.37	4.35	4.45	6.35	3.43	3.9
						2	1.38	1.4						
	M3 X 0.5	LK	LKS	LKA	M3	1	0.97	1	4.75	4.73	4.85	6.35	3.43	4
						2	1.38	1.4						
	M4 X 0.7	LK	LKS	LKA	M4	1	0.97	1	6.76	6.73	6.2	8.73	4.45	5.2
						2	1.38	1.4						
	M5 X 0.8	LK	LKS	LKA	M5	1	0.97	1	7.92	7.9	7.4	9.53	5.21	5.6
						2	1.38	1.4						

# SELF-LOCKING FASTENERS

## PL™/PLC™ PEMHEX® LOCKNUTS



- Thread locking torque performance is equivalent to applicable NASM25027 specifications.
- The strong knurled collar receives the installation force and resists torque.
- The spin resistance of the knurl greatly exceeds the torque that can be exerted by the self-locking feature.

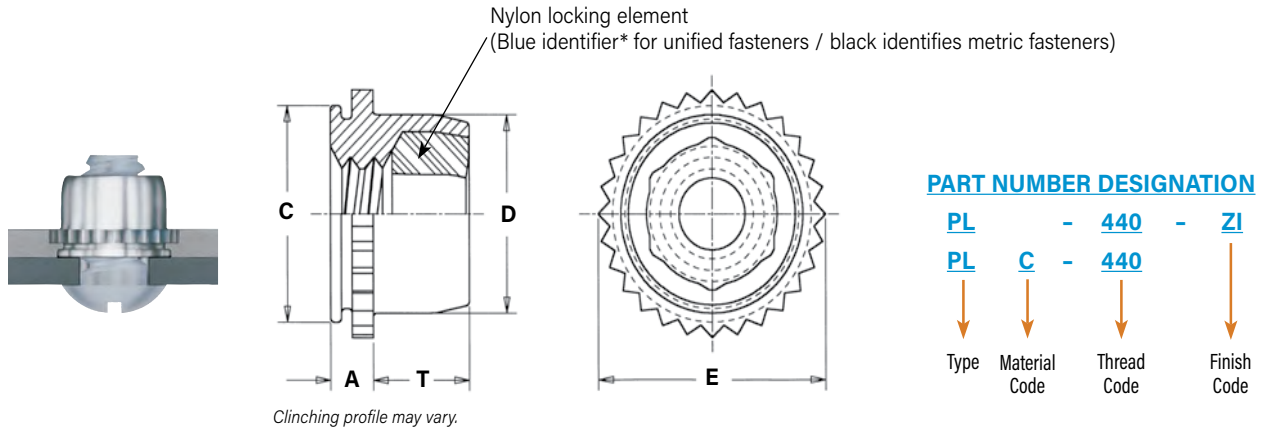

All dimensions are in inches.

UNIFIED	Thread Size	Type		Thread Code	A (Shank) Max.	Sheet Thickness (1) (2)	Hole Size In Sheet +.003 -.000	C Max.	D Max.	E Max.	T Max.	Min. Dist. Hole $\varnothing$ to Edge	Max. Hole In Attached Parts
		Fastener Material											
		Steel	Stainless Steel										
.112-40 (#4-40)	PL	PLC	440	.060	.040 - .070	.234	.233	.215	.274	.130	.170	.132	
.138-32 (#6-32)	PL	PLC	632	.060	.040 - .070	.265	.264	.246	.305	.130	.190	.158	
.164-32 (#8-32)	PL	PLC	832	.060	.040 - .070	.297	.296	.278	.338	.155	.220	.184	
.190-32 (#10-32)	PL	PLC	032	.060	.040 - .070	.312	.311	.293	.353	.165	.250	.210	

All dimensions are in millimeters.

METRIC	Thread Size x Pitch	Type		Thread Code	A (Shank) Max.	Sheet Thickness (1) (2)	Hole Size In Sheet +0.08	C Max.	D Max.	E Max.	T Max.	Min. Dist. Hole $\varnothing$ to Edge	Max. Hole In Attached Parts
		Fastener Material											
		Steel	Stainless Steel										
M3 x 0.5	PL	PLC	M3	1.53	1 - 1.78	6	5.98	5.52	7.01	3.56	4.32	3.5	
M4 x 0.7	PL	PLC	M4	1.53	1 - 1.78	7.5	7.48	7.01	8.54	4.2	5.59	4.5	
M5 x 0.8	PL	PLC	M5	1.53	1 - 1.78	8	7.98	7.52	9	4.45	6.35	5.5	

(1) Can be used in panel thickness of .040" to .060"/1 mm to 1.53 mm provided the fastener is not fully installed. The knurled collar must be left protruding above the sheet to the degree that the sheet thickness is less than .060"/1.53 mm. See installation instructions.

(2) Knurled collar may fracture if fastener is used in sheets thicker than .070"/1.78 mm and screw is tightened beyond maximum tightening torque.

\*PEM Trademark.



Get quote »

Angic Global Solutions

1-888-872-0690 [www.angic.com](http://www.angic.com) 111

<https://www.AngicGlobal.com> Sales@AngicGlobal.com

# SELF-LOCKING FASTENERS

## SL™ TRI-DENT® LOCKNUTS



- SL locknuts meet 3 cycle locking performance <sup>(1)</sup>.
- Recommended for use in sheets HRB (Rockwell "B" scale) 80 or less and HB (Hardness Brinell) 150 or less.

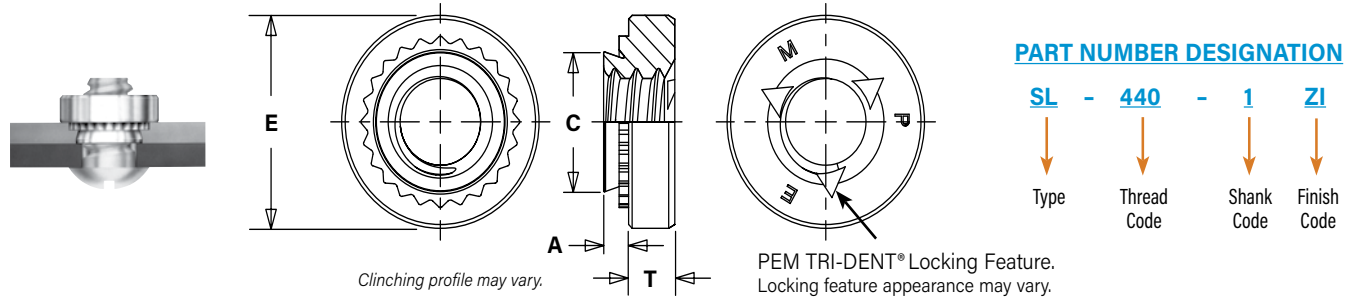

All dimensions are in inches.

UNIFIED	Thread Size	Type	Thread Code	Shank Code	A (Shank) Max.	Min. Sheet Thickness	Hole Size In Sheet +.003 -.000	C Max.	E ±.010	T ±.010	Min. Dist. Hole $\varnothing$ to Edge
	.112-40 (#4-40)	SL	440	1	.038	.040	.166	.165	.250	.070	.19
				2	.054	.056					
	.138-32 (#6-32)	SL	632	1	.038	.040	.1875	.187	.280	.070	.22
				2	.054	.056					
	.164-32 (#8-32)	SL	832	1	.038	.040	.213	.212	.310	.090	.27
				2	.054	.056					
	.190-32 (#10-32)	SL	032	1	.038	.040	.250	.249	.340	.090	.28
				2	.054	.056					
	.250-20 (1/4-20)	SL	0420	1	.054	.056	.344	.343	.440	.170	.34
				2	.087	.091					
	.313-18 (5/16-18)	SL	0518	1	.054	.056	.413	.412	.500	.230	.38
2				.087	.091						

All dimensions are in millimeters.

METRIC	Thread Size x Pitch	Type	Thread Code	Shank Code	A (Shank) Max.	Min. Sheet Thickness	Hole Size In Sheet +0.08	C Max.	E ±0.25	T ±0.25	Min. Dist. Hole $\varnothing$ to Edge
	M3 x 0.5	SL	M3	1	0.98	1	4.22	4.2	6.35	1.5	4.8
				2	1.38	1.4					
	M3.5 x 0.6	SL	M3.5	1	0.98	1	4.75	4.73	7.11	1.5	5.6
				2	1.38	1.4					
	M4 x 0.7	SL	M4	1	0.98	1	5.41	5.38	7.87	2	6.9
				2	1.38	1.4					
	M5 x 0.8	SL	M5	1	0.98	1	6.35	6.33	8.64	2	7.1
				2	1.38	1.4					
	M6 x 1	SL	M6	1	1.38	1.4	8.75	8.73	11.18	4.08	8.6
				2	2.21	2.3					
	M8 x 1.25	SL	M8	1	1.38	1.4	10.5	10.47	12.7	5.47	9.7
2				2.21	2.3						
M10 x 1.5	SL	M10	1	2.21	2.29	14	13.97	17.35	7.48	13.5	
			2	3.05	3.18						

(1) Achieved using steel socket head cap screws, 180 ksi / property class 12.9 with standard finish of thermal oxide and light oil.

# SELF-LOCKING FASTENERS

## PEM RT® FREE-RUNNING LOCKNUTS

Free-running locking feature allows screw to turn freely until clamp load is applied. If the tightening force is removed, these nuts no longer provide any torsional resistance to rotation until clamp load is reapplied.

- Resistant to vibrational loosening.
- Back side of panel is flush or sub-flush for screw installation.
- Locking feature reusability is not affected by number of on/off cycles.
- Uses same mounting hole and installation tooling as standard S™ nuts.
- Recommended for use in steel or aluminum sheets HRB 80 / HB 150 or less.

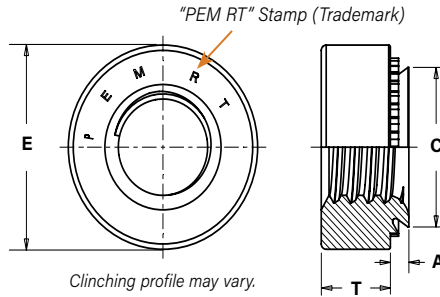

### PART NUMBER DESIGNATION

**S** - **RT632** - **1** **ZI**  
 ↓                      ↓                      ↓                      ↓  
 Type                      Thread Size Code                      Shank Code                      Finish

All dimensions are in inches.

UNIFIED	Thread Size	Type	Thread Code	Shank Code	A (Shank) Max.	Rec. Min. Sheet Thickness (t)	Hole Size In Sheet +.003 -.000	C Max.	E ±.010	T ±.010	Min. Dist Hole To Edge
	.112-40 (#4-40)	S	RT440	0	.030	.030	.166	.165	.250	.070	.19
			1	.038	.040						
			2	.054	.056						
.138-32 (#6-32)	S	RT632	0	.030	.030	.1875	.187	.280	.070	.22	
			1	.038	.040						
			2	.054	.056						
.164-32 (#8-32)	S	RT832	0	.030	.030	.213	.212	.310	.090	.27	
			1	.038	.040						
			2	.054	.056						
.190-32 (#10-32)	SS	RT032	0	.030	.030	.250	.249	.340	.090	.28	
			1	.038	.040						
			2	.054	.056						
.250-20 (1/4-20)	S	RT0420	0	.045	.047	.344	.343	.440	.170	.34	
			1	.054	.056						
			2	.087	.090						
.313-18 (5/16-18)	S	RT0518	1	.054	.056	.413	.412	500	.230	.38	
			2	.087	.090						

All dimensions are in millimeters

METRIC	Thread Size x Pitch	Type	Thread Code	Shank Code	A (Shank) Max.	Rec. Min. Sheet Thickness (t)	Hole Size In Sheet +0.08	C Max.	E ±0.25	T ±0.25	Min. Dist Hole To Edge
	M3 x 0.5	S	RTM3	0	0.77	0.8	4.22	4.2	6.35	1.5	4.8
1				0.97	1						
2				1.38	1.4						
M4 x 0.7	S	RTM4	0	0.77	0.8	5.41	5.38	7.87	2	6.9	
			1	0.97	1						
			2	1.38	1.4						
M5 x 0.8	SS	RTM5	0	0.77	0.8	6.35	6.33	8.64	2	7.1	
			1	0.97	1						
			2	1.38	1.4						
M6 x 1	S	RTM6	00	0.89	0.92	8.75	8.73	11.18	4.08	8.6	
			0	1.15	1.2						
			1	1.38	1.4						
			2	2.21	2.29						
M8 x 1.25	S	RTM8	1	1.38	1.4	10.49	10.47	12.7	5.47	9.7	
			2	2.21	2.29						

The graph represents the clamp load of the joint versus the amount of cycles during transverse vibration testing for a PEM RT® free-running locknut, a standard S nut, a split ring lock washer and Loctite Red 271.

### Testing conditions:

Transverse vibration testing.  
 M6 thread size nuts, average of 30 pieces.  
 Clamp load applied using metric property class 10.9 screws.  
 Nuts tested until loss of clamp load or 2,000 cycles is reached.

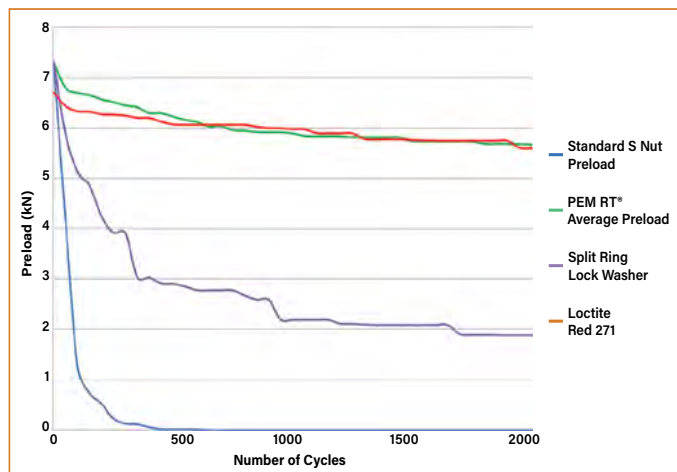

Details on PEM RT® vibration resistant thread technology can be found on our web site at:

[https://www.pemnet.com/files/design\\_info/techsheets/RT\\_Thread\\_Form.pdf](https://www.pemnet.com/files/design_info/techsheets/RT_Thread_Form.pdf)



Get quote >>

Angic Global Solutions

1-888-872-0690 [www.angic.com](http://www.angic.com) 113

<https://www.AngicGlobal.com> Sales@AngicGlobal.com

# SELF-LOCKING FASTENERS

## MATERIAL AND FINISH SPECIFICATIONS

Type	Threads				Fastener Material									
	Internal, ASME B1.1, 2B / ASME B1.13M, 6H	Internal, ASME B1.1, 3B / ASME B1.13M, 6H	Internal, UNJ Class 3B per ASME B1.15 / MJ Class 4H6H per ASME B1.21M (M6 thread 4H5H)	(1) Modified Thread Form on Loaded Flank	Hardened Carbon Steel	Carbon Steel	300 Series Stainless Steel	(2) 7075-T6 Aluminum	Nylon Locking Element Blue or Black Temperature Limit 250° F / 120° C	Floating Fastener				
										Retainer	Retainer	Retainer	Nut	
CFN	▪					▪			▪					
FE			▪											
FEO			▪											
UL			▪											
LAS			▪							▪				▪
LAC			▪										▪	▪
LA4			▪									▪		▪
LK		▪				▪								
LKS		▪									▪			
LKA		▪								▪				
PL	▪									▪				
PLC	▪									▪				
SL	▪													
PEM RT®				▪	▪									

Type	Standard Finishes (3)							Optional Finish (3)(4)	For Use In Sheet Hardness: (5)							
	Zinc Plated per ASTM B633, SC1 (5µm), Type III, Colorless	Passivated and/or Tested Per ASTM A380	Passivated Plus Clear Dry-film Lubricant	(6) Black Dry-film Lubricant	(7) Black Dry-film Lubricant Over Phosphate	Plain	Floating Fastener			Zinc Plated per ASTM B633, SC1 (5µm), Type III, Yellow	HRB 88/ HB 183 or Less	HRB 80/ HB 150 or Less	HRB 70/ HB 125 or Less	HRB 60/ HB 107 or Less	HRB 50/ HB 89 or Less	
							Retainer		Retainer							Nut
CFN	▪								▪					▪		
FE				▪										▪		
FEO				▪										▪		
UL			▪											▪		
LAS										▪				▪		
LAC											▪			▪		
LA4												▪		▪		
LK					▪									▪		
LKS				▪										▪		
LKA															▪	
PL	▪													▪		
PLC		▪												▪		
SL	▪													▪		
PEM RT®	▪													▪		
<b>Finish Codes</b>	ZI	None	CW	MD	MD				MD	ZC						

- (1) Will accept a maximum material 6g/2A screw.
- (2) Mating screws must be lubricated.
- (3) See PEM Technical Support section of our web site for related plating standards and specifications.
- (4) Special order with additional charge.
- (5) HRB - Hardness Rockwell "B" Scale. HB - Hardness Brinell.
- (6) MD finish on stainless steel provides a minimum of 100 hours of salt spray resistance.
- (7) MD finish on steel provides a minimum of 24 hours of salt spray resistance.

# SELF-LOCKING FASTENERS

## INSTALLATION

### INSTALLATION NOTES

- For best results we recommend using a Haeger® or PEMSERTER® machine for installation of PEM® self-clinching fasteners. Please check our website for more information.
- Visit the Animation Library on our website to view the installation process [for select products](#).

### CFN™ NUTS

- Prepare properly sized mounting hole in sheet. Do not perform any secondary operations such as deburring.
- Insert fastener into the anvil hole and place the mounting hole over the shank of the fastener (preferably the punch side) as shown in drawing.
- With installation punch and anvil surfaces parallel, apply squeezing force until the shoulder of the fastener contacts the sheet.

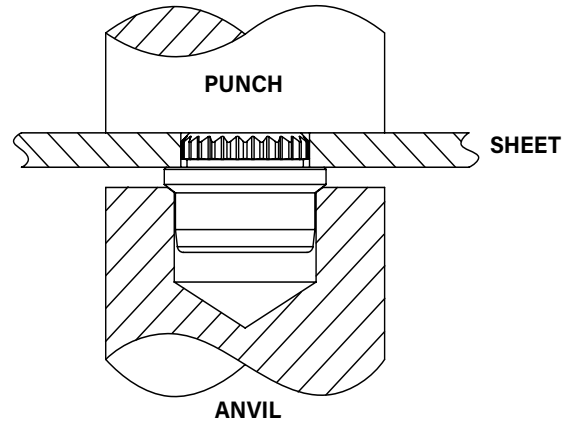

### PEMSERTER® Installation Tooling

Type	Thread Code	Anvil Part Number	Punch Part Number
CFN	440/M3	8012038	975200048

### FE™/FEO™/UL™ NUTS

- Prepare properly sized mounting hole in sheet. Do not perform any secondary operations such as deburring.
- Insert fastener into the anvil hole and place the mounting hole (preferably the punch side) over the shank of the fastener as shown in the drawing.
- With installation punch and anvil surfaces parallel, apply squeezing force to the knurled collar until knurled collar is flush with top of the sheet for sheets .060"/1.5 mm thick and up, or until shank is flush with the bottom of the sheet for sheets .040" / 1 mm to .060"/1.5 mm thick for FE/FEO nuts.

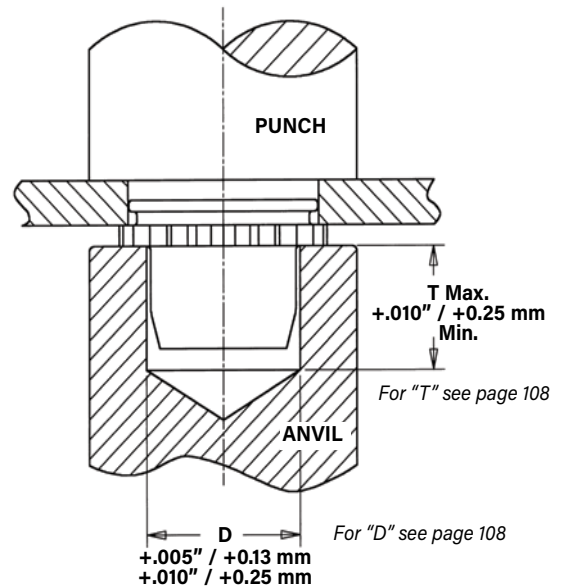

PEM miniature fasteners must be installed by a force applied through parallel surfaces. Since force must not be applied to the barrel, a cavity must be used in either the punch or anvil so that the installation force is applied to the knurled collar. "D" dimensions for the punch or anvil cavity are given in the tables on page 5.

## INSTALLATION RECOMMENDATION

In applications for sheet thicknesses between the two ranges (see "Sheet Thickness" on page 5) use the fastener with the larger "A" dimension. For example, if you want a #4-40 thread and your sheet thickness is between .045"/1.14 mm and .059"/1.49 mm, you should use FE or FEX nuts. This is not recommended installation practice, but in this case if it is necessary, you should install the fastener so that the bottom of the shank is flush with the underside of the sheet (instead of having the top of the knurled collar flush with the top of the sheet). When this method is used, care must be taken to protect the fastener against crushing which would damage the threads. This method will also result in reduced pushout and torque-out values.

### PEMSERTER® Installation Tooling

Type	Thread Code	Anvil Part Number	Punch Part Number
UL	256/M2	975200020	975200048
FE/FEO	440/M3	975200021	975200048
FE/FEO	632/M3.5	975200022	975200048
FE/FEO	832/M4	975200023	975200048
FE/FEO	032/M5	975200024	975200048
FE/FEO	0420	975200025	975200048
FE/FEO	M6	8013143	975200048



Get quote »

Angic Global Solutions

1-888-872-0690 [et.com 115](#)

<https://www.AngicGlobal.com> [Sales@AngicGlobal.com](mailto:Sales@AngicGlobal.com)

# SELF-LOCKING FASTENERS

## LAS™/LAC™/LA4™ NUTS

1. Prepare properly sized mounting hole in sheet. Do not perform any secondary operations such as deburring.
2. Place fastener into the anvil hole and place the mounting hole (preferably the punch side) over the shank of the fastener.
3. With installation punch and anvil surfaces parallel, apply sufficient squeezing force until flange contacts mounting sheet (LAC/LAS) or until anvil contacts the mounting sheet (LA4). Drawings show suggested tooling for applying these forces.

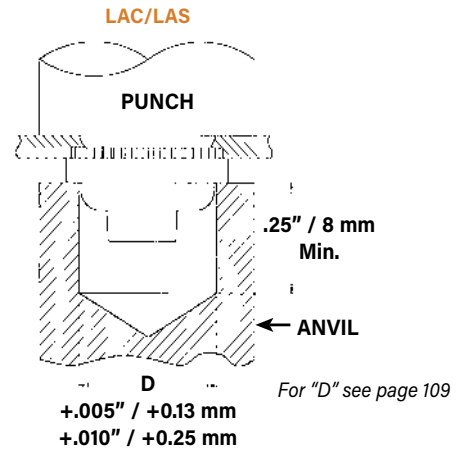

## PEMSERTER® Installation Tooling

Type	Thread Code	Anvil Part Number	Punch Part Number
LAC/LAS	440/M3	975200006	975200048
LAC/LAS	632	8013890	975200048
LAC/LAS	832/M4	8013891	975200048
LAC/LAS	032/M5	8013892	975200048
LAC/LAS	0420/M6	975200010	975200048

Type	Thread Code	Anvil Part Number	Punch Part Number
LA4	440/M3	8013889	975200048
LA4	632	8013890	975200048
LA4	832/M4	8013891	975200048
LA4	032/M5	8013892	975200048

## LA4 Tooling for installation into stainless steel sheets

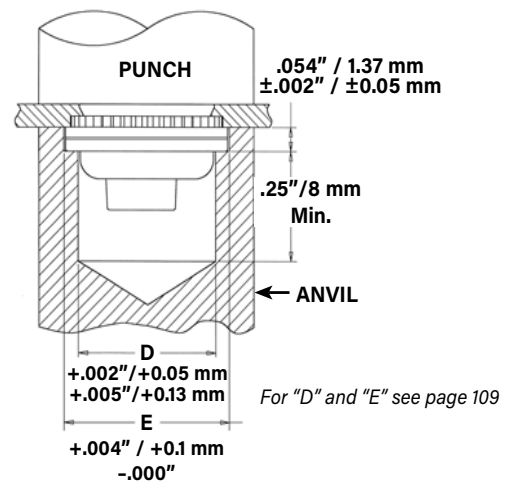

## LK™/LKS™/LKA™ NUTS

1. Prepare properly sized mounting hole in sheet. Do not perform any secondary operations such as deburring.
2. Insert fastener into the anvil hole and place the mounting hole over the shank of fastener (preferably the punch side) as shown in drawing.
3. With installation punch and anvil surfaces parallel, apply squeezing force until hexagonal shoulder contacts mounting sheet. Sketch at the right shows suggested tooling for applying these forces. Installation force and performance data shown below.

## PEMSERTER® Installation Tooling

Type	Thread Code	Anvil Part Number	Punch Part Number
LK/LKS/LKA	256/M2.5	975200015	975200048
LK/LKS/LKA	440/M3	975200016	975200048
LK/LKS/LKA	632	975201242	975200048
LK/LKS/LKA	832/M4	975201241	975200048
LK/LKS/LKA	032/M5	975200019	975200048

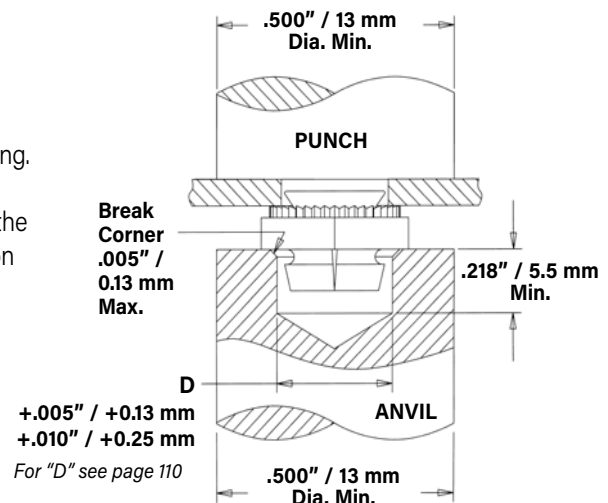

# SELF-LOCKING FASTENERS

## PL™/PLC™ NUTS

Sheet thickness .060" to .070" / 1.53 mm to 1.78 mm

1. Prepare properly sized mounting hole in sheet. Do not perform any secondary operations such as deburring.
2. Insert fastener into the anvil hole and place the mounting hole over the shank of the fastener (preferably the punch side) as shown in drawing.
3. With the punch and anvil surfaces parallel, apply a squeezing force until the knurled collar is flush with the top sheet.

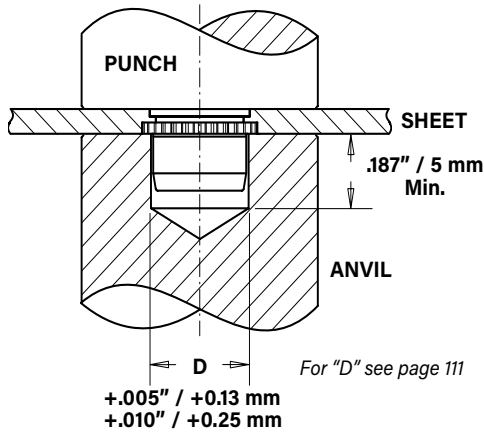

## PEMSERTER® Installation Tooling

Type	Thread Code	Anvil Part Number	Punch Part Number
PL/PLC	440/M3	975200011	975200048
PL/PLC	632	975200012	975200048
PL/PLC	832/M4	975200013	975200048
PL/PLC	032/M5	975200014	975200048

Sheet thickness .040" to .060" / 1 mm to 1.53 mm

1. Prepare properly sized mounting hole in sheet. Do not perform any secondary operations such as deburring.
2. Insert fastener into the anvil hole and place the mounting hole over the shank of the fastener (preferably the punch side) as shown in drawing.
3. With the punch and anvil surfaces parallel, apply a squeezing force until the fastener shank is flush with the underside of the sheet. This should be accomplished by setting the depth of the counterbore in the anvil to the difference between the "A" dimension and the sheet thickness\*. When this method is used, care must be taken to protect the fastener against crushing which would damage the threads. This method will also result in reduced pushout and torque-out values.

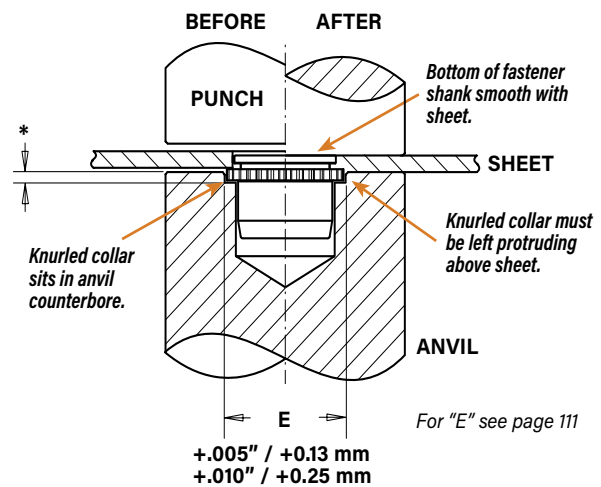

# SELF-LOCKING FASTENERS

## SL™ NUTS

1. Prepare properly sized mounting hole in sheet. Do not perform any secondary operations such as deburring.
2. Insert fastener into the anvil hole and place the mounting hole over the shank of the fastener (preferably the punch side) as shown in drawing.
3. With installation punch and anvil surfaces parallel, apply squeezing force until the head of the nut comes into contact with the sheet material.

**COUNTERBORE ANVIL**  
Thread Sizes #2-56 to 5/16  
and M2 to M8

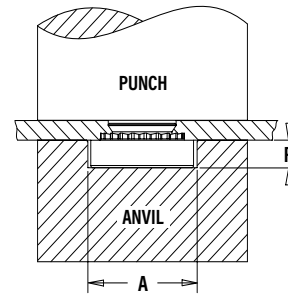

**PROTRUSION ANVIL**  
CLS/S Nuts Thread Sizes 3/8, 1/2, M10 and M12

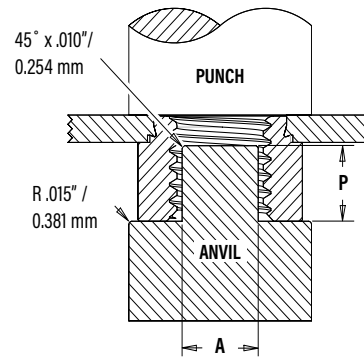

## PEMSERTER® Installation Tooling

UNIFIED	Thread Code	Anvil Dimensions (in.)		Anvil Part Number	Punch Part Number
		A ±.002	P ±.005		
	440	.267	.045	975200034	975200048
	632	.298	.045	975200035	975200048
	832	.330	.070	975200036	975200048
	032	.361	.070	975200037	975200048
	0420	.454	.150	975200038	975200048
	0518	.515	.200	975200039	975200048
	0616	.280	.250	975200045 <sup>(1)</sup>	975200048

METRIC	Thread Code	Anvil Dimensions (mm)		Anvil Part Number	Punch Part Number
		A ±0.05	P ±0.13		
	M3	6.78	1.14	975200034	975200048
	M3.5	7.57	1.14	975200035	975200048
	M4	8.38	1.78	975200036	975200048
	M5	9.17	1.78	975200037	975200048
	M6	11.53	3.81	975200038	975200048
	M8	13.08	5.08	975200039	975200048
	M10	7.62	6.35	8005682 <sup>(1)</sup>	975200901400

(1) Large nut anvils use protrusion to locate part instead of counterbore.

## PEM RT® NUTS

1. Prepare properly sized mounting hole in sheet. Do not perform any secondary operations such as deburring.
2. Place fastener into the anvil hole and place the mounting hole (preferably the punch side) over the shank of the fastener as shown in diagram to the right.
3. With installation punch and anvil surfaces parallel, apply squeezing force until the head of the nut comes into contact with the sheet material.

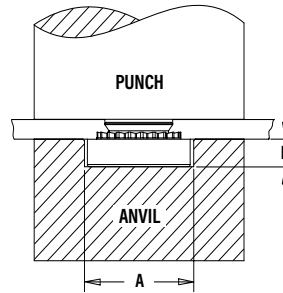

## PEMSERTER® Installation Tooling

UNIFIED	Thread Code	Anvil Dimensions (in.)		Anvil Part Number	Punch Part Number
		A ±.002	P ±.005		
	RT440	.267	.045	975200034	975200048
	RT632	.298	.045	975200035	975200048
	RT832	.330	.070	975200036	975200048
	RT032	.361	.070	975200037	975200048
	RT0420	.454	.150	975200038	975200048
	RT0518	.517	.200	975200039	975200048

METRIC	Thread Code	Anvil Dimensions (mm)		Anvil Part Number	Punch Part Number
		A ±0.05	P ±0.13		
	RTM3	6.78	1.14	975200034	975200048
	RTM4	8.38	1.78	975200036	975200048
	RTM5	9.17	1.78	975200037	975200048
	RTM6	11.53	3.81	975200038	975200048
	RTM8	13.08	5.08	975200039	975200048

# SELF-LOCKING FASTENERS

## CLINCH FASTENER PERFORMANCE DATA

### CFN™ NUTS (1)

UNIFIED	Thread Code	Thread Locking Specifications		Test Sheet Material		
		Max. First On Prevailing Torque (in. lbs.)	Min. First Off Prevailing Torque (in. lbs.)	.040" Cold-rolled Steel		
				Installation (lbs.)	Pushout (lbs.)	Torque-out (in. lbs.)
	440	3	0.38	1000	10	4

METRIC	Thread Code	Thread Locking Specifications		Test Sheet Material		
		Max. First On Prevailing Torque (N-m)	Min. First Off Prevailing Torque (N-m)	1 mm Cold-rolled Steel		
				Installation (kN)	Pushout (N)	Torque-out (N-m)
	M3	0.339	0.042	4.45	44.5	0.45

### FE™/FEO™/UL™ NUTS (1)(2)

UNIFIED	Type	Thread Code	Test Sheet Material					
			5052-H34 Aluminum			Cold-rolled Steel		
			Installation (lbs.)	Pushout (lbs.)	Torque-out (in. lbs.)	Installation (lbs.)	Pushout (lbs.)	Torque-out (in. lbs.)
	FEO	440	900	88	12	1500	140	12
	FE			135	12		210	12
	FEO	632	1200	105	20	2100	185	20
	FE			1300			175	
	FEO	832	1500	155	48	2500	260	48
	FE			255			360	
	FEO	032	1500	155	48	2500	260	48
	FE			255			360	
	FE	0420	2100	320	110	3500	420	110
		0428						

METRIC	Type	Thread Code	Test Sheet Material					
			5052-H34 Aluminum			Cold-rolled Steel		
			Installation (kN)	Pushout (N)	Torque-out (N-m)	Installation (kN)	Pushout (N)	Torque-out (N-m)
	FEO	M3	4	391	1.35	6.7	622	1.35
	FE			600			934	
	FEO	M4	6.7	689	5.42	11.1	1156	5.42
	FE			1134			1601	
	FEO	M5	6.7	689	5.42	11.1	1156	5.42
	FE			1134			1601	
	FE	M6	9.4	1423	12.43	15.6	1868	12.43

UNIFIED	Type	Thread Code	Shank Code	Test Sheet Material					
				5052-H34 Aluminum			Cold-rolled Steel		
				Installation (lbs.)	Pushout (lbs.)	Torque-out (in. lbs.)	Installation (lbs.)	Pushout (lbs.)	Torque-out (in. lbs.)
	UL	080	0	750	20	2	1000	30	2
		164	0	750	20	3	1000	30	3
		256	0 1	1000	20	4	1300	30	4

METRIC	Type	Thread Code	Shank Code	Test Sheet Material					
				5052-H34 Aluminum			Cold-rolled Steel		
				Installation (kN)	Pushout (N)	Torque-out (N-m)	Installation (kN)	Pushout (N)	Torque-out (N-m)
	UL	M2	1	4	89	0.45	5.8	133	0.45

- (1) Published installation forces are for general reference. Actual set-up and confirmation of complete installation should be made by observing proper seating of fastener as described in the installation steps. Other performance values reported are averages when all proper installation parameters and procedures are followed. Variations in mounting hole size, sheet material, and installation procedure may affect performance. Performance testing this product in your application is recommended. We will be happy to provide technical assistance and/or samples for this purpose.
- (2) For FE and FEO fasteners, thread locking performance is equivalent to applicable NASM25027 specifications. For details, see chart on page 124.



Get quote >>

Angic Global Solutions

1-888-872-0690 [et.com](http://www.AngicGlobal.com) 119

<https://www.AngicGlobal.com> Sales@AngicGlobal.com

# SELF-LOCKING FASTENERS

## LAS™/LAC™ NUTS <sup>(1)(2)</sup>

UNIFIED	Thread Code	Shank Code	Test Sheet Material								
			2024-T3 Aluminum			5052-H34 Aluminum			Cold-Rolled Steel		
			Installation (lbs.)	Retainer Pushout (lbs.)	Retainer Torque-out (in. lbs.)	Installation (lbs.)	Retainer Pushout (lbs.)	Retainer Torque-out (in. lbs.)	Installation (lbs.)	Retainer Pushout (lbs.)	Retainer Torque-out (in. lbs.)
440	1	3000	220	65	1500	215	65	3000	300	85	
	2		225	150	2000	225	80			150	
632	1	3000	235	110	2000	240	140	3000	300	150	
	2		275	150		250	150			175	
832	1	3000	240	110	2000	250	140	3000	300	150	
	2		300	150		265	150		400	200	
032	1	3500	300	150	2000	300	150	3500	400	150	
	2			200		350	175		450	200	
0420 0428	2	5000	300	325	3000	400	325	5000	500	325	

METRIC	Thread Code	Shank Code	Test Sheet Material								
			2024-T3 Aluminum			5052-H34 Aluminum			Cold-Rolled Steel		
			Installation (kN)	Retainer Pushout (N)	Retainer Torque-out (N-m)	Installation (kN)	Retainer Pushout (N)	Retainer Torque-out (N-m)	Installation (kN)	Retainer Pushout (N)	Retainer Torque-out (N-m)
M3	1		13.3	978	7.3	6.7	956	7.3	13.3	1334	9.6
	2		13.3	1000	16.9	8.9	1000	9	13.3	1334	16.9
M4	1		13.3	1067	12.4	8.9	1112	15.8	13.3	1334	16.9
	2		15.6	1334	16.9	8.9	1178	16.9	13.3	1779	22.6
M5	1		15.6	1334	16.9	8.9	1334	16.9	15.6	1779	16.9
	2		16.6	1334	22.6	8.9	1556	19.7	15.6	2001	22.6
M6	2		22.2	1334	36.7	13.3	1779	36.7	22.2	2224	36.7

## LA4™ NUTS <sup>(1)(2)</sup>

UNIFIED	Thread Code	Test Sheet Material		
		300 Series Stainless Steel		
		Installation (lbs.)	Retainer Pushout (lbs.)	Retainer Torque-out (in. lbs.)
440		9000	200	85
632		10000	200	85
832		12000	200	85
032		13000	250	125

METRIC	Thread Code	Test Sheet Material		
		300 Series Stainless Steel		
		Installation (kN)	Retainer Pushout (N)	Retainer Torque-out (N-m)
M3		40	890	9.6
M4		53	890	9.6
M5		57	1100	14.1

(1) Published installation forces are for general reference. Actual set-up and confirmation of complete installation should be made by observing proper seating of fastener as described in the installation steps. Other performance values reported are averages when all proper installation parameters and procedures are followed. Variations in mounting hole size, sheet material, and installation procedure may affect performance. Performance testing this product in your application is recommended. We will be happy to provide technical assistance and/or samples for this purpose.

(2) Thread locking performance is equivalent to applicable NASM25027 specifications. For details, see chart on page 124.

# SELF-LOCKING FASTENERS

## LK™/LKS™/LKA™ NUTS (1)(2)

UNIFIED	Thread Code	Shank Code	Test Sheet Material					
			5052-H34 Aluminum			Cold-rolled Steel		
			Installation (lbs.)	Pushout (lbs.)	Torque-out (in. lbs.)	Installation (lbs.)	Pushout (lbs.)	Torque-out (in. lbs.)
256	1	1600	130	20	3000	150	20	
	2	2000	150	30	3000	160	20	
440	1	1600	130	25	3000	150	30	
	2	2000	200	35	3000	250	40	
632	1	2400	130	25	4000	150	45	
	2	2700	225	45	4300	275	50	
832	1	2700	150	45	4000	190	50	
	2	3000	250	50	4300	300	70	
032	1	3200	150	90	4000	250	100	
	2	3200	250	105	4300	300	120	

METRIC	Thread Code	Shank Code	Test Sheet Material					
			5052-H34 Aluminum			Cold-rolled Steel		
			Installation (kN)	Pushout (N)	Torque-out (N-m)	Installation (kN)	Pushout (N)	Torque-out (N-m)
M2.5	1	7.1	578	2.3	13.3	667	2.3	
	2	8.9	667	3.4	13.3	711	2.3	
M3	1	7.1	578	2.8	13.3	667	3.4	
	2	8.9	890	4	13.3	1112	4.5	
M4	1	12	667	5.1	17.8	845	5.6	
	2	13.3	1112	5.7	19.1	1334	7.9	
M5	1	14.2	667	10.2	17.8	1112	11.3	
	2	14.2	1112	11.9	19.1	1334	13.6	

## PL™/PLC™ NUTS (1)(2)

UNIFIED	Thread Code	Test Sheet Material											
		.060" 5052-H34 Aluminum			.040" 5052-H34 Aluminum			.060" Cold-rolled Steel			.048" Cold-rolled Steel		
		Installation (lbs.)	Pushout (lbs.)	Torque-out (in. lbs.)	Installation (lbs.)	Pushout (lbs.)	Torque-out (in. lbs.)	Installation (lbs.)	Pushout (lbs.)	Torque-out (in. lbs.)	Installation (lbs.)	Pushout (lbs.)	Torque-out (in. lbs.)
440	2000	225	20	1500	160	20	3000	260	20	3000	225	20	
632	2000	285	30	1500	180	25	3000	290	30	3000	270	30	
832	2000	290	60	1500	180	28	3000	290	60	3000	270	60	
032	2000	300	70	1500	180	40	3000	350	70	3000	310	70	

METRIC	Thread Code	Test Sheet Material											
		1.5 mm 5052-H34 Aluminum			1 mm 5052-H34 Aluminum			1.5 mm Cold-rolled Steel			1.2 mm Cold-rolled Steel		
		Installation (kN)	Pushout (N)	Torque-out (N · m)	Installation (kN)	Pushout (N)	Torque-out (N · m)	Installation (kN)	Pushout (N)	Torque-out (N · m)	Installation (kN)	Pushout (N)	Torque-out (N · m)
M3	8.9	1000	2.25	6.67	710	2.25	13.34	1156	2.25	13.34	1000	2.25	
M4	8.9	1290	6.77	6.67	800	3.16	13.34	1290	6.77	13.34	1200	6.77	
M5	8.9	1330	7.9	6.67	800	4.51	13.34	1557	7.9	13.34	1380	7.9	

(1) Published installation forces are for general reference. Actual set-up and confirmation of complete installation should be made by observing proper seating of fastener as described in the installation steps. Other performance values reported are averages when all proper installation parameters and procedures are followed. Variations in mounting hole size, sheet material, and installation procedure may affect performance. Performance testing this product in your application is recommended. We will be happy to provide technical assistance and/or samples for this purpose.

(2) Thread locking performance is equivalent to applicable NASM25027 specifications. For details, see chart on page 124.



Get quote »

Angic Global Solutions

1-888-872-0690 [et.com](https://www.AngicGlobal.com) 121

<https://www.AngicGlobal.com> Sales@AngicGlobal.com

# SELF-LOCKING FASTENERS

## SL™ NUTS (1)

UNIFIED	Thread Code	Shank Code	Thread Locking Specifications		Test Sheet Material					
			Max. Prevailing Torque (1st thru 3rd) (in. lbs.)	Min. Prevailing Torque (1st thru 3rd) (in. lbs.)	5052-H34 Aluminum			Cold-rolled Steel		
					Installation (lbs.)	Pushout (lbs.)	Torque-out (in. lbs.)	Installation (lbs.)	Pushout (lbs.)	Torque-out (in. lbs.)
440	1	2	5.75	0.4	1500 - 2000	90	10	2500 - 3500	125	15
	2					170	13		230	18
632	1	2	10.5	0.8	2500 - 3000	95	17	3000 - 6000	130	20
	2					190	22		275	28
832	1	2	18	1.2	2500 - 3000	105	23	4000 - 6000	145	35
	2					220	35		285	45
032	1	2	21	1.65	2500 - 3000	110	32	4000 - 9000	180	40
	2					190	50		250	60
0420	1	2	35	3.75	4000 - 7000	360	90	6000 - 9000	400	150
	2					360	125		400	150
0518	1	2	53	4.75	4000 - 7000	380	120	6000 - 8000	420	165
	2					380	160		420	180
0616	1	2	95	6.3	5000 - 8000	400	270	7000 - 11000	460	320
	2					400	270		460	320

METRIC	Thread Code	Shank Code	Thread Locking Specifications		Test Sheet Material					
			Max. Prevailing Torque (1st thru 3rd) (N-m)	Min. Prevailing Torque (1st thru 3rd) (N-m)	5052-H34 Aluminum			Cold-rolled Steel		
					Installation (kN)	Pushout (N)	Torque-out (N-m)	Installation (kN)	Pushout (N)	Torque-out (N-m)
M3	1	2	0.67	0.04	6.7 - 8.9	400	1.13	11.2 - 15.6	550	1.7
	2					750	1.47		1010	2.03
M3.5	1	2	1.2	0.08	11.2 - 13.5	400	1.92	13.4 - 26.7	570	2.3
	2					840	2.5		1210	2.3
M4	1	2	2.1	0.13	11.2 - 13.4	470	2.6	18 - 27	645	4
	2					970	4		1250	5.1
M5	1	2	2.4	0.18	11.2 - 15.6	480	3.6	18 - 38	800	4.5
	2					845	5.7		1112	6.8
M6	1	2	4	0.3	18 - 32	1580	10.2	27 - 36	1760	17
	2					1580	14.1		1760	17
M8	1	2	6	0.5	18 - 32	1570	13.6	27 - 36	1870	18.7
	2					1570	18.1		1870	20.3
M10	1	2	12	0.8	22 - 36	1760	32.7	32 - 50	2020	36.2
	2					1760	32.7		2020	36.2

(1) Published installation forces are for general reference. Actual set-up and confirmation of complete installation should be made by observing proper seating of fastener as described in the installation steps. Other performance values reported are averages when all proper installation parameters and procedures are followed. Variations in mounting hole size, sheet material, and installation procedure may affect performance. Performance testing this product in your application is recommended. We will be happy to provide technical assistance and/or samples for this purpose.

# SELF-LOCKING FASTENERS

## PEM RT® NUTS (1)

UNIFIED	Type	Thread Code	Shank Code	Test Sheet Material	Installation (lbs.)	Pushout (lbs.)	Torque-out (in. lbs.)	
	S	RT440	0	5052-H34 Aluminum	1500-2000	63	8	
						1	90	10
						2	170	13
			1	Cold-rolled Steel		105	13	
						125	15	
						230	18	
	S	RT632	0	5052-H34 Aluminum	2500-3000	63	16	
						1	95	17
						2	190	22
1			Cold-rolled Steel	110		16		
				130		20		
				275		28		
S	RT832	0	5052-H34 Aluminum	2500-3000	68	21		
					1	105	23	
					2	220	35	
		1	Cold-rolled Steel		110	26		
					145	35		
					285	45		
SS	RT032	0	5052-H34 Aluminum	2500-3500	68	26		
					1	110	32	
					2	190	50	
		1	Cold-rolled Steel		120	32		
					180	40		
					320	60		
S	RT0420	0	5052-H34 Aluminum	4000-7000	220	70		
					1	360	90	
					2	125	125	
		1	Cold-rolled Steel		315	115		
					400	150		
S	RT0518	1	5052-H34 Aluminum	4000-7000	380	120		
		2				160		
		1	Cold-rolled Steel			6000-8000	165	
		2					180	

METRIC	Type	Thread Code	Shank Code	Test Sheet Material	Installation (kN)	Pushout (N)	Torque-out (N-m)	
	S	RTM3	0	5052-H34 Aluminum	6.7-8.9	280	0.9	
						1	400	1.13
						2	750	1.47
			1	Cold-rolled Steel		470	1.47	
						550	1.7	
						1010	2.03	
	S	RTM4	0	5052-H34 Aluminum	11.2-13.4	300	2.37	
						1	470	2.6
						2	970	4
1			Cold-rolled Steel	490		2.95		
				645		4		
				1250		5.1		
SS	RTM5	0	5052-H34 Aluminum	11.2-15.6	300	3		
					1	480	3.6	
					2	845	5.7	
		1	Cold-rolled Steel		530	3.6		
					800	4.5		
					1112	6.8		
S	RTM6	00	5052-H34 Aluminum	18-32	750	6.5		
					0	970	7.9	
					1	1580	10.2	
		1	Cold-rolled Steel		14.1	14.1		
					900	10		
					1380	13		
			1760	17				

(1) Published installation forces are for general reference. Actual set-up and confirmation of complete installation should be made by observing proper seating of fastener as described in the installation steps. Other performance values reported are averages when all proper installation parameters and procedures are followed. Variations in mounting hole size, sheet material, and installation procedure may affect performance. Performance testing this product in your application is recommended. We will be happy to provide technical assistance and/or samples for this purpose.



Get quote »

Angic Global Solutions

1-888-872-0690 [www.AngicGlobal.com](http://www.AngicGlobal.com) 123

<https://www.AngicGlobal.com> Sales@AngicGlobal.com

# SELF-LOCKING FASTENERS

## AXIAL STRENGTH AND TIGHTENING TORQUE COMPARISON

Thread Code	Increasing Axial Strength →														
	Types UL-0/FEO			Types UL-1/FE			Types PL/PLC			Type SL			Types LK/LKA/LKS/LAC/LAS/LA4		
	Locknut Min. Axial Strength (lbs.) <sup>(1)</sup>	Mating Screw		Locknut Min. Axial Strength (lbs.) <sup>(1)</sup>	Mating Screw		Locknut Min. Axial Strength (lbs.) <sup>(1)</sup>	Mating Screw		Locknut Min. Axial Strength (lbs.) <sup>(4)</sup>	Mating Screw		Locknut Min. Axial Strength (lbs.) <sup>(7)</sup>	Mating Screw	
	Strength Level (ksi) <sup>(2)</sup>	Tightening Torque (in. lbs.) <sup>(3)</sup>		Strength Level (ksi) <sup>(2)</sup>	Tightening Torque (in. lbs.) <sup>(3)</sup>		Strength Level (ksi) <sup>(2)</sup>	Tightening Torque (in. lbs.) <sup>(3)</sup>		Strength Level (ksi) <sup>(4)</sup>	Tightening Torque (in. lbs.) <sup>(5)</sup>		Strength Level (ksi) <sup>(7)</sup>	Tightening Torque (in. lbs.) <sup>(5)</sup>	
080	125	69	1.0	—	—	—	—	—	—	—	—	—	—	—	
164	125	49	1.2	—	—	—	—	—	—	—	—	—	—	—	
256	169	46	1.9	316	85	3.5	—	—	—	—	—	—	—	—	
440	465	77	6.8	705	117	10.3	897	149	13.1	1,085	180	15.8	1,085	180	15.8
632	546	60	9.8	847	93	15.2	1,036	114	18.6	1,636	180	29.4	1,636	180	29.4
832	779	56	16.6	1,213	87	25.9	1,179	84	25.1	2,270 <sup>(6)</sup>	180	48.4	2,522	180	53.8
032	779	39	19.2	1,213	61	30.0	1,246	62	30.8	2,880 <sup>(6)</sup>	180	71.1	3,600	180	88.9
0420	—	—	—	1,412	44	45.9	—	—	—	5,728	180	186	5,728	180	186
0518	—	—	—	—	—	—	—	—	—	9,437	180	383	—	—	—
0616	—	—	—	—	—	—	—	—	—	13,948	180	680	—	—	—

Thread Code	Increasing Axial Strength →														
	Types UL-0/FEO			Types UL-1/FE			Types PL/PLC			Type SL			Types LK/LKA/LKS/LAC/LAS/LA4		
	Locknut Min. Axial Strength (kN) <sup>(1)</sup>	Mating Screw		Locknut Min. Axial Strength (kN) <sup>(1)</sup>	Mating Screw		Locknut Min. Axial Strength (kN) <sup>(1)</sup>	Mating Screw		Locknut Min. Axial Strength (kN) <sup>(4)</sup>	Mating Screw		Locknut Min. Axial Strength (kN) <sup>(7)</sup>	Mating Screw	
	Strength Level (MPa) <sup>(2)</sup>	Tightening Torque (N-m) <sup>(3)</sup>		Strength Level (MPa) <sup>(2)</sup>	Tightening Torque (N-m) <sup>(3)</sup>		Strength Level (MPa) <sup>(2)</sup>	Tightening Torque (N-m) <sup>(3)</sup>		Strength Level (MPa) <sup>(4)</sup>	Tightening Torque (N-m) <sup>(5)</sup>		Strength Level (MPa) <sup>(7)</sup>	Tightening Torque (N-m) <sup>(5)</sup>	
M2	—	—	—	1.39	432	0.36	—	—	—	—	—	—	—	—	—
M3	2.08	267	0.81	3.16	405	1.23	4.03	517	1.57	6.14	1220	2.39	6.14	1220	2.39
M4	3.48	255	1.81	5.42	398	2.82	5.21	382	2.71	9.64 <sup>(6)</sup>	1220	5.01	10.71	1220	5.57
M5	3.48	158	2.26	5.42	246	3.52	5.6	255	3.64	12.63 <sup>(6)</sup>	1220	8.21	17.3	1220	11.2
M6	—	—	—	6.28	201	4.9	—	—	—	24.55	1220	19.1	24.55	1220	19.1
M8	—	—	—	—	—	—	—	—	—	44.66	1220	46.5	—	—	—
M10	—	—	—	—	—	—	—	—	—	70.75	1220	92	—	—	—

- (1) Axial strength for UL, FEO, FE, PL and PLC locknuts are limited by knurled ring strength.
- (2) Screw strength level shown is the minimum needed to develop full nut strength, higher strength screws may be used.
- (3) Tightening torque shown will induce preload of 65% of locknut min axial strength with K or nut factor is equal to 0.20. In some applications tightening torque may need to be adjusted based on the actual K value. If heat treated steel screw strength is less than the value shown, tightening torque should be proportionately reduced by multiplying the torque shown by the actual screw strength over the screw strength shown. For screws of other materials, never exceed the lower of this reduced torque or the tightening torque recommended for the screw. If higher strength screws are used, torque is not adjusted upward because assemble strength is still limited by locknut strength.
- (4) Unless otherwise noted, (see note 6) SL locknuts have axial strength exceeding the min tensile strength of 180 ksi/Property Class 12.9 screws. Contact tech support regarding assemble strength for higher strength screws.
- (5) Tightening torque shown will induce preload of 65% of locknut min axial strength with K or nut factor is equal to 0.20. In some applications tightening torque may need to be adjusted based on the actual K value. All tightening torques shown are based on 180 ksi/ Property Class 12.9 screws. For lower strength heat treated steel screws the tightening torque is proportionately less. For example, for 120 ksi screws (Grade 5), torque is 67% of value shown. For 900 MPa screws (Property Class 9.8) torque value is 74% of value shown. For screws of other materials, never exceed the lower of this reduced torque or the tightening torque recommended for the screw.
- (6) Due to limited nut height in this size, failure mode is screw stripping and axial strength value shown is slightly less than min tensile strength of 180 ksi/ Property class 12.9 screw.
- (7) All LK, LKS, LKA, LAC, LAS and LA4 locknuts have axial strength exceeding the min tensile strength of 180 ksi/Property Class 12.9 screws. Contact tech support regarding assemble strength for higher strength screws.

# SELF-LOCKING FASTENERS

## NASM25027 AS APPLIED TO PEM® SELF-CLINCHING, SELF-LOCKING NUTS

PEM FE, FEO, LAS, LAC, LA4, LK, LKS, LKA, PL and PLC locknuts are produced to meet the prevailing locking torque requirements of NASM25027. Specification NASM25027 is a rather lengthy spec which includes many requirements for attributes such as tensile strength and wrenching strength which are not applicable to PEM self-clinching, self-locking nuts. It is difficult for those not familiar with the specification to determine exactly which portions of it apply to the locking torque of PEM self-clinching, self-locking nuts. This matter is further complicated by the fact that many of the requirements in the specification that do apply, apply only to qualification and are not so called "quality conformance inspections" which need to be applied to every lot of product. The fact of the matter is that only one test (room ambient temperature locking torque per the first row of Table IV) needs to be applied on a regular basis of PEM self-clinching, self-locking nuts. This requirement is defined by Table XIV and the permanent set test is not required per footnote 1. The requirements for this test are given in Paragraphs 3.8.2.2.1 and 3.8.2.2.2. The test method is specified in paragraphs 4.5.3.3. and 4.5.3.3.4.1. For convenience of those who do not have access to this specification and/or are not familiar with specification language, these test requirements and test methods are re-stated below in layman's terms.

The one required test is a 15 cycle re-usability test. There are two values of torque which are required by specification. The first is a maximum torque value which dare not be exceeded anytime during the 15 installation and removal cycles. The second is a minimum breakaway torque which must be met during the 15th removal cycle. These torque values are shown in Table III of specifications NASM25027. They are also listed below for PEM fastener sizes only and also for metric sizes.

Details of the test procedure and significant definitions can be found on our web site at:  
[http://www.pemnet.com/files/design\\_info/techsheets/NASM25027.pdf](http://www.pemnet.com/files/design_info/techsheets/NASM25027.pdf)

Thread Size	Maximum Locking Torque (Any Cycle)		Minimum 15th Cycle Breakaway Torque	
	in. lbs.	N•m	in. lbs.	N•m
#2-56	2.5	0.28	0.2	0.023
#4-40	5	0.57	0.5	0.057
#6-32	10	1.13	1.0	0.113
#8-32	15	1.7	1.5	0.17
#10-24	18	2.03	2.0	0.226
#10-32	18	2.03	2.0	0.226
1/4-20	30	3.39	4.5	0.509
1/4-28	30	3.39	3.5	0.396
M2.5	3.8	0.43	0.38	0.043
M3	5	0.56	0.5	0.056
M3.5	10	1.13	1.0	0.113
M4	15	1.7	1.5	0.17
M5	18	2.03	2.0	0.22
M6	28.3	3.2	3.3	0.37



# SELF-LOCKING FASTENERS

<b>PEM® Double Squares</b> (Registered Trademark)	<b>PEM® Blue Nylon Locking Element</b> (Registered Trademark)	<b>PEM® Stamp</b> (Registered Trademark)	<b>PEM RT® Stamp</b> (Trademark)
			

**To be sure that you are getting genuine PEM® brand fasteners, look for the unique PEM product markings and identifiers.**



Get quote »



PEM® brand microPEM® fasteners  
are ideal for today's and tomorrow's  
compact electronics



**MPF™**  
micro **PEM®**  
FASTENERS

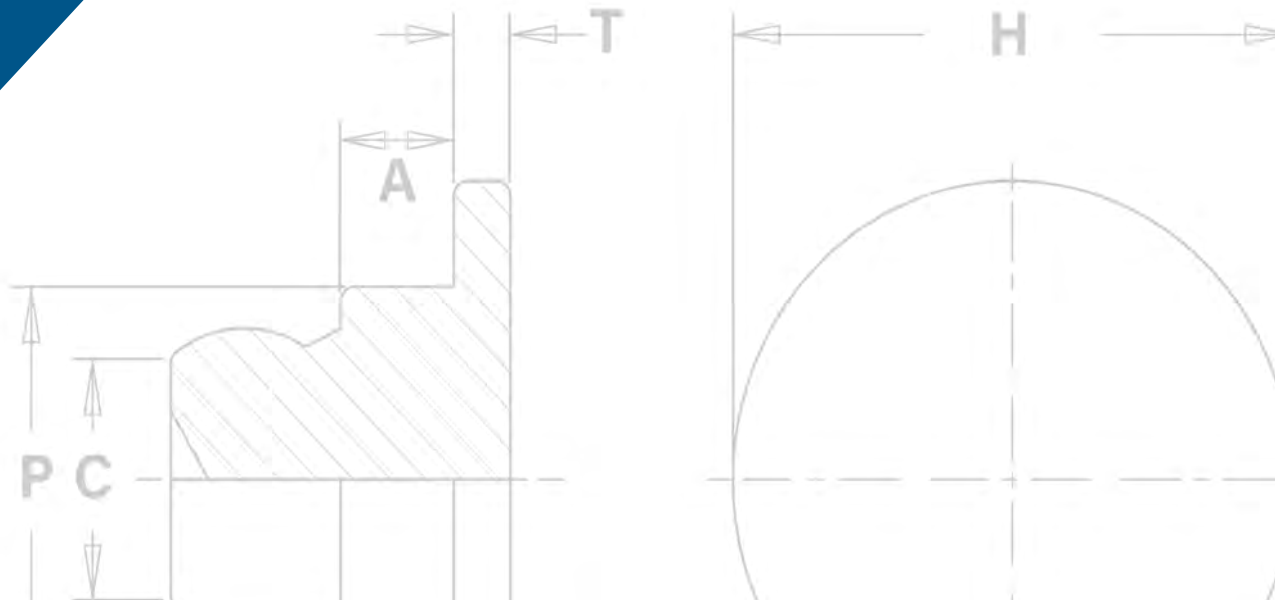

Get quote »

Angic Global Solutions

1-888-872-0690

<https://www.AngicGlobal.com> [Sales@AngicGlobal.com](mailto:Sales@AngicGlobal.com)

## IDEAL FOR TODAY'S AND TOMORROW'S COMPACT ELECTRONICS

- Wearables (smart watches, cameras, fitness bands, headphones, etc.)
- Laptops
- Tablets/eReaders
- Cell/Smart Phones
- Gaming/Hand Held Devices/Virtual Reality
- Infotainment/Automotive Electronics



Parts for smaller and/or thinner applications have been designed. Please contact us for more information.

<p><b>MPP™ microPEM® Self-clinching Pins</b> Ideal for positioning and alignment applications- <b>PAGE 129</b></p>		<p><b>MSIA™/MSIB™ microPEM® Inserts For Plastics</b> Designed for use in straight or tapered holes. The symmetrical design eliminates the need for orientation. They are installed by pressing them into the mounting hole with ultrasonic equipment or with a thermal press - <b>PAGE 134</b></p>	
<p><b>MSO4™ microPEM® Self-clinching Standoffs</b> Designed for mounting and/or spacing in extremely limited space applications - <b>PAGE 129</b></p>		<p><b>MSOFS™ microPEM® Flaring Standoffs</b> Attach permanently in any type of panel, including metal, plastic and PC board. Flaring feature allows for captivation of multiple panels - <b>PAGE 135</b></p>	
<p><b>TA™/T4™ microPEM® TackPin® Fasteners</b> Enable sheet-to-sheet attachment, replacing costly screw installation in applications where disassembly is not required - <b>PAGE 130</b></p>		<p><b>SMTSO™ microPEM® Surface Mount Fasteners</b> These fasteners for compact electronic assemblies attach to PC boards for nut/standoff applications. These fasteners mount on PC boards in the same manner and at the same time as other surface mount components prior to the automated reflow solder process - <b>PAGE 136</b></p>	
<p><b>TKA™/TK4™ microPEM® TackSert® Pins</b> Enables attachment of metal sheets to plastic, replacing costly screw installation in applications where disassembly is not required - <b>PAGE 131</b></p>		<p><b>microPEM® Screws</b> Available in thread codes as small as M0.8 and lengths as short as 1 mm / .039" - <b>PAGE 137</b></p>	
<p><b>TFA™ microPEM® FLEXTACK™ FASTENERS</b> The Bellville washer shaped head of the microPEM® FlexTack™ fastener is designed to increase vertical installation tolerance in designs - <b>PAGE 132</b></p>	<p><b>NEW</b></p>	<p><b>Material and finish specifications - PAGE 138</b></p>	
<p><b>TS4™ microPEM® TackScrew™ Fasteners</b> Enable cost effective sheet-to-sheet attachment by simply pressing into place. Can be removed by simply unscrewing, similar to other threaded fasteners - <b>PAGE 132</b></p>		<p><b>Installation - PAGES 139 - 142</b></p>	
<p><b>CDS™ microPEM® ClampDisk® Fasteners</b> Press straight onto a 1 mm pin to replace threads, adhesive, rivets and other small fasteners - <b>PAGE 133</b></p>		<p><b>Performance data - PAGES 143 - 144</b></p>	



Fastener drawings and models are available at [www.pemnet.com](http://www.pemnet.com)



## MPP™ microPEM® SELF-CLINCHING PINS

- Satisfy demanding micro positioning and alignment applications
- Head mounts flush into panels as thin as 0.5 mm / .020"
- Chamfered end makes mating hole alignment easy
- Can be installed into stainless steel sheets
- Excellent corrosion resistance
- Can be installed automatically



### PART NUMBER DESIGNATION

**MPP - 1MM - 2**

MPP → Type & Material  
 1MM → Pin Diameter Code  
 2 → Length Code

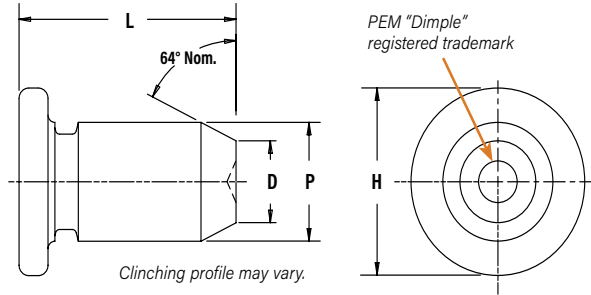

Pin Diameter P ±0.038mm	Type Stainless Steel	Pin Diameter Code	Length Code "L" ± 0.15 mm (Length Code in millimeters)							Min. Sheet Thickness		Hole Size In Sheet +0.025 mm / +.001"		D ±0.1 mm / ±.004"		H ±0.25 mm / ±.010"		Min. Distance Hole ⌀ to Edge	
			2	3	4	5	-	-	-	mm	in.	mm	in.	mm	in.	mm	in.	mm	in.
1	MPP	1MM	2	3	4	5	-	-	-	0.5	.020	1.05	.041	0.7	.028	1.6	.063	2.05	.081
1.5	MPP	1.5MM	-	3	4	5	6	8	-	0.5	.020	1.55	.061	1.03	.041	2.24	.088	2.6	.102
2	MPP	2MM	-	-	4	5	6	8	10	0.5	.020	2.05	.081	1.36	.054	3.02	.119	4.4	.173

## MSO4™ microPEM® SELF-CLINCHING STANDOFFS

- Designed for mounting and/or spacing in extremely limited space applications
- Can be installed into stainless steel sheets<sup>(1)</sup>
- Have stronger threads than weld standoffs because they are made from heat-treated 400 Series Stainless Steel
- Can be installed automatically



### PART NUMBER DESIGNATION

**MSO 4 - 080 - 3**

MSO → Type  
 4 → Material Code  
 080 → Thread Code  
 3 → Length Code

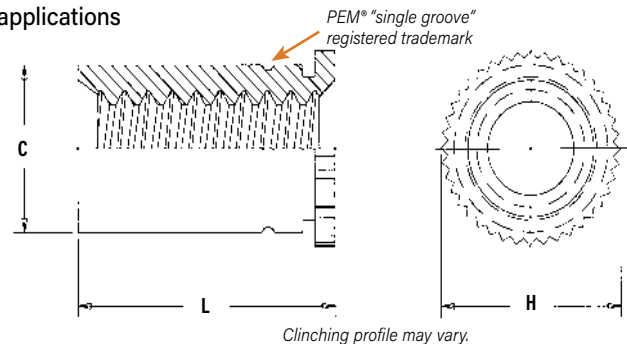

All dimensions are in inches.

UNIFIED	Thread Size	Type	Thread Code	Length Code	Min. Sheet Thickness	Hole Size In Sheet +.002 -.000	C Max.	H Nom.	L +.002 -.003	Min. Dist. Hole ⌀ To Edge
		Stainless Steel								
	.060-80 (#0-80) <sup>(2)</sup>	MSO4	080	3	.012	.095	.094	.125	.094	.090
				4					.125	
	.086-56 (#2-56) <sup>(2)</sup>	MSO4	256	3	.012	.125	.124	.156	.094	.120
				4					.125	

All dimensions are in millimeters.

METRIC	Thread Size	Type	Thread Code	Length Code	Min. Sheet Thickness	Hole Size In Sheet +.05	C Max.	H Nom.	L +0.05 - 0.08	Min. Dist. Hole ⌀ To Edge
		Stainless Steel								
	M1 x 0.25 <sup>(3)</sup>	MSO4	M1	2	0.3	2.41	2.39	3.18	2	2.3
				3					3	
	M1.2 x 0.25 <sup>(3)</sup>	MSO4	M1.2	2	0.3	2.41	2.39	3.18	2	2.3
				3					3	
	M1.4 x 0.3 <sup>(4)</sup>	MSO4	M1.4	2	0.3	2.41	2.39	3.18	2	2.3
				3					3	
M1.6 x 0.35 <sup>(5)</sup>	MSO4	M1.6	2	0.3	2.41	2.39	3.18	2	2.3	
			3					3		
M2 x 0.4 <sup>(5)</sup>	MSO4	M2	2	0.3	3.18	3.16	3.96	2	3	
			3					3		

(1) MSO4 standoffs are designed for use in sheet hardness HRB 88 / HB 183 or less. For installation into harder sheets (up to HRC 36), contact our Tech Support line or your local representative.

(2) Unified ASME B1.1, 2B

(3) Miniature ISO 68-1, 5H

(4) Miniature ISO 68-1, 6H

(5) Metric ASME B1.13M, 6H



Get quote >>

Angic Global Solutions

1-888-872-0690 [www.angic.com](http://www.angic.com) 129

<https://www.AngicGlobal.com> Sales@AngicGlobal.com

## TA™/T4™ microPEM® TackPin® FASTENERS

- Reduce installation time vs. a screw
- Simple, press in installation eliminates many costs and concerns associated with micro screws:
  - Cross threading
  - Tapping
  - Tightening torque control
  - Vibrational back-out
- Low profile head provides space savings
- Tapered tip aligns fastener in hole
- Interference fit minimizes hole tolerance issues
- Easily installed automatically



### Comparison of TackPin® fastener to screw installation.

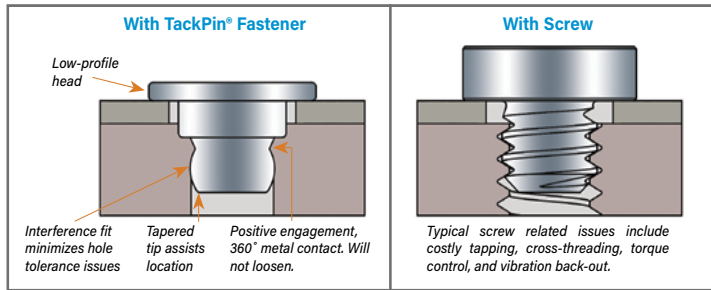

### PART NUMBER DESIGNATION

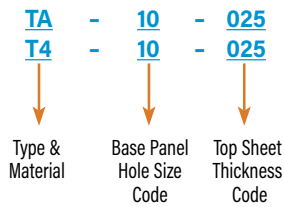

PEM® "Dimple" registered trademark

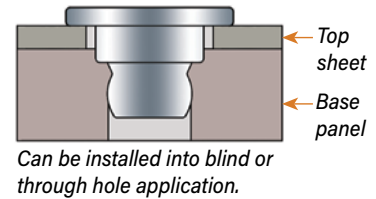
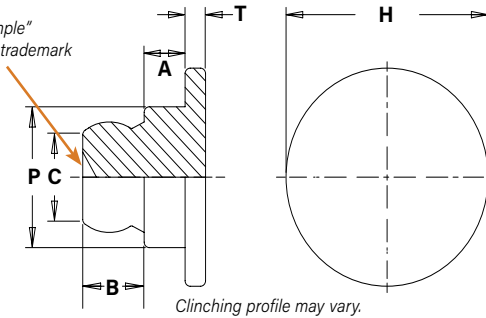

Type	Aluminum	Stainless Steel	Base Panel Hole Size Code	Top Sheet Thickness Code	Top Sheet Thickness		Base Panel Min. Sheet Thickness (1)		Top Sheet Hole Size ±0.05 mm / ±.002"		Base Panel Hole Size -0.05 mm / -.002"		A ±0.025 mm / ±.001"		B ±0.075 mm / ±.003"		C Max.	H ±0.1 mm / ±.004"		P ±0.05 mm / ±.002"		T ±0.1 mm / ±.004"		Min. Dist. Hole To Edge	
					mm	in.	mm	in.	mm	in.	mm	in.	mm	in.	mm	in.		mm	in.	mm	in.	mm	in.		
TA	T4	10	025	0.2-0.28	.008-.011	0.89	.035	1.47	.058	1.02	.040	0.406	.016	0.610	.024	0.89	.035	2	.079	1.3	.051	0.2	.008	1	.039
TA	T4	10	050	0.48-0.56	.019-.022	0.89	.035	1.47	.058	1.02	.040	0.686	.027	0.610	.024	0.89	.035	2	.079	1.3	.051	0.2	.008	1	.039
TA	-	10	075	0.71-0.79	.028-.031	0.89	.035	1.47	.058	1.02	.040	0.914	.036	0.610	.024	0.89	.035	2	.079	1.3	.051	0.2	.008	1	.039

(1) 0.89 mm / .035" for blind holes and 0.5 mm / .020" for through holes.

TackPin® and TackSert® fasteners have been specified to replace screws to attach a super-thin membrane to a very thin substrate in keyboards. The switch to TackPin® fasteners significantly reduced assembly costs.

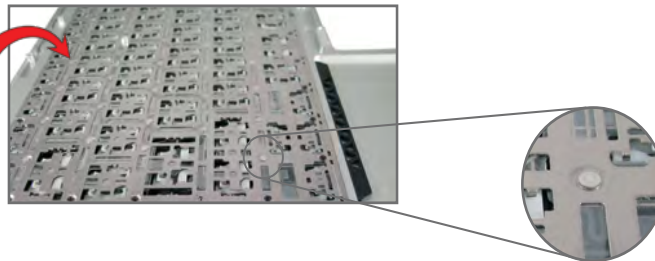

## CUSTOM microPEM® TackPin® FASTENER SOLUTIONS

### Countersunk TackPin® Fastener

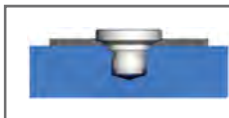

- Installs into a countersunk hole, replacing countersunk screws.
- Offers flush or near flush appearance.

### Large Head TackPin® Fastener

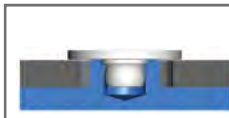

- TackPin with a large head installed into boss of bottom panel.
- Holds down top panel that is free to rotate around the boss.

### Flush-head TackPin® Fastener

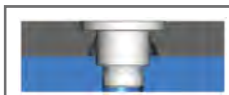

- TackPin installed into a thicker, softer top-sheet and pressed flush.

### Thin Sheet TackPin® Fastener



- Simple, press-in installation.
- Enables sheet-to-sheet attachment of multiple layers.
- Flush or sub-flush on both sides of sheet.
- Head mounts flush into top sheets as thin as .008" / 0.2 mm.

### FlexTack™ Fastener

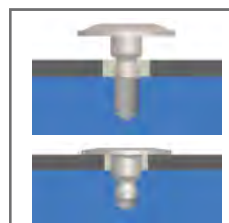

- The bellville shaped head flattens upon a simple press-in installation.
- Draws panels together to accommodate vertical stack tolerances.

## TKA™/TK4™ microPEM® TackSert® PINS

- Suitable for installation into plastics, metal castings and other brittle materials
- Reduce installation time vs. a screw
- Simple, press in installation (does not require heat or ultrasonics) eliminates many costs and concerns associated with micro screws:
  - Cross threading
  - Use of inserts / tapping
  - Tightening torque control
  - Vibrational back-out
- Low profile head provides space savings
- Tapered tip aligns fastener in hole
- Easily installed automatically

### Comparison of TackSert® pin to screw installation.

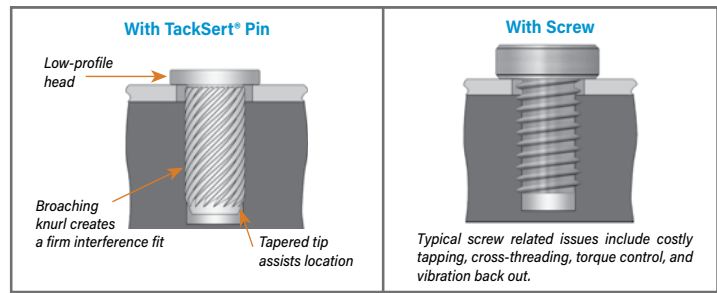

### PART NUMBER DESIGNATION

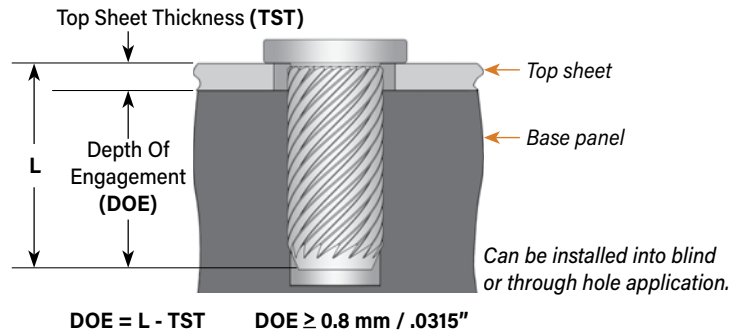
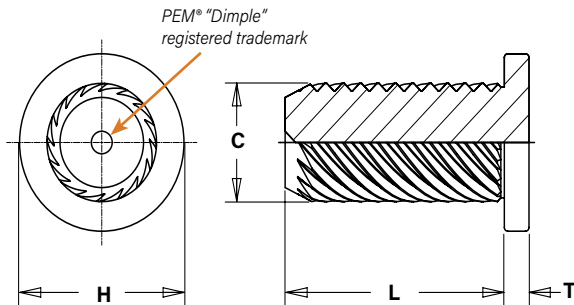
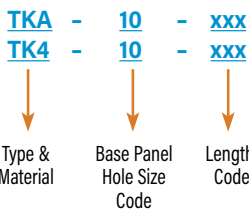

#### For through hole applications

DOE - 0.25 mm / .010" = Min. Sheet

#### For blind hole applications

DOE + 0.25 mm / .010" = Min. Blind Hole Depth

Type		Base Panel Hole Size Code	Length Code	Top Sheet Hole Size ±0.05 mm/±.002"		Base Panel Hole Size -0.05 mm/-.002"		Top Sheet Thickness Max.		C Max.	H ±0.08 mm/±.003"	L ±0.06 mm/±.002"		T ±0.08 mm/±.003"		Min. Dist. Hole $\varnothing$ To Edge (1)			
Aluminum	400 series stainless steel			mm	in.	mm	in.	mm	in.			mm	in.	mm	in.	mm	in.	mm	in.
TKA	TK4	10	100	1.3	.051	1	.039	0.2	.008	1.2	.047	1.8	.071	1	.039	0.27	.011	1.18	.047
TKA	TK4	10	150	1.3	.051	1	.039	0.7	.028	1.2	.047	1.8	.071	1.5	.059	0.27	.011	1.18	.047
TKA	TK4	10	200	1.3	.051	1	.039	1.2	.047	1.2	.047	1.8	.071	2	.079	0.27	.011	1.18	.047
TKA	TK4	10	250	1.3	.051	1	.039	1.7	.067	1.2	.047	1.8	.071	2.5	.098	0.27	.011	1.18	.047
TKA	TK4	10	300	1.3	.051	1	.039	2.2	.087	1.2	.047	1.8	.071	3	.118	0.27	.011	1.18	.047

(1) Minimum boss diameter is twice centerline-to-edge value.

## TFA™ microPEM® FLEXTACK™ FASTENERS

The Belleville washer shaped head of the microPEM® FlexTack™ fastener is designed to increase vertical installation tolerance in designs.

- Alternative to using micro-screws, eliminating the need to tap or use threaded inserts.
- Installation time to simply press the part in (1.5 seconds) is less than the time to thread a screw in, equals less total installed cost.
- The Belleville-shaped head allows for stack-up tolerance relief in a design.
- Lowers overall total installed costs from the elimination of the following:
  - Cost of screw, patch to prevent loosening, threaded insert or tapped hole and driver bits
  - Cost of rework due to cross-threading or driver bit "cam-out"

**NEW**

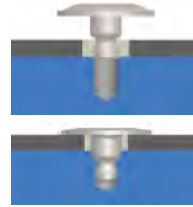

The Belleville shaped head flattens upon a simple press-in installation and draws panels together to accommodate vertical stack tolerances.

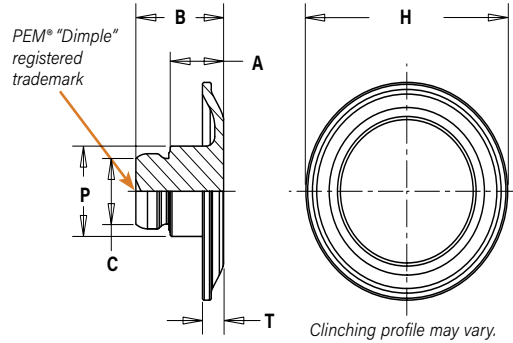

### PART NUMBER DESIGNATION



Patented

**TFA - 10 - 025**

Type & Material    Base Panel Hole Size Code    Top Sheet Thickness Code

Type	Base Panel Hole Size Code	Top Sheet Thickness Code	Top Sheet Thickness		Base Panel Min. Sheet Thickness <sup>(1)</sup>		Top Sheet Hole Size ±0.05 mm / ±.002"		Base Panel Hole Size -0.05 mm / -.002"		A ±0.04 mm / ±.0015"		B ±0.08 mm / ±.003"		C Max.		H ±0.1 mm / ±.004"		P ±0.05 mm / ±.002"		T ±0.1 mm / ±.004"		Min. Dist. Hole To Edge	
			mm	in.	mm	in.	mm	in.	mm	in.	mm	in.	mm	in.	mm	in.	mm	in.	mm	in.	mm	in.		
TFA	10	025	0.18 - 0.28	.007 - .011	0.89	.035	1.47	.058	1.02	.040	0.67	.026	1.16	.046	0.89	.035	2.91	.115	1.21	.048	0.3	.012	1	.039
TFA	10	035	0.28 - 0.38	.011 - .015	0.89	.035	1.47	.058	1.02	.040	0.77	.030	1.26	.050	0.89	.035	2.91	.115	1.21	.048	0.3	.012	1	.039
TFA	10	045	0.38 - 0.48	.015 - .019	0.89	.035	1.47	.058	1.02	.040	0.87	.034	1.37	.054	0.89	.035	2.91	.115	1.21	.048	0.3	.012	1	.039
TFA	10	055	0.48 - 0.58	.019 - .023	0.89	.035	1.47	.058	1.02	.040	0.97	.038	1.47	.058	0.89	.035	2.91	.115	1.21	.048	0.3	.012	1	.039

(1) 0.89 mm / .035" for blind holes and 0.5 mm / .020" for through holes.

## TS4™ microPEM® TackScrew™ FASTENERS

- Allows for 1-cycle re-usability by unscrewing and then reinstallation with thread locking adhesive
- Reduce installation time vs. a screw
- Simple, press in installation eliminates many costs and concerns associated with micro screws:
  - Cross threading
  - Tapping
  - Tightening torque control
  - Vibrational back-out
- Low profile head provides space savings
- Tapered tip aligns fastener in hole
- Interference fit minimizes hole tolerance issues
- Easily installed automatically

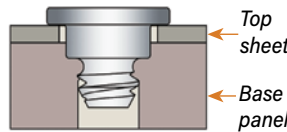

Can be installed into blind or through hole applications.

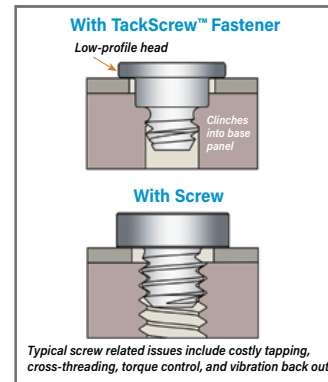

### PART NUMBER DESIGNATION



Patented

**TS4 - 10 - 025**

Type & Material    Base Panel Hole Size Code    Top Sheet Thickness Code

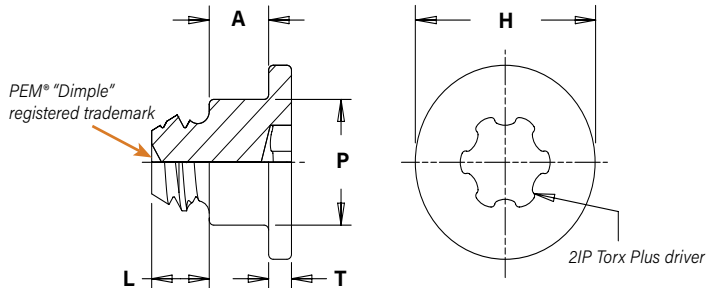

Type Material	Base Panel Hole Size Code	Top Sheet Thickness Code	Top Sheet Thickness		Base Panel Min. Sheet Thickness <sup>(2)</sup>		Top Sheet Hole Size ±0.05 mm / ±.002"		Base Panel Hole Size ±0.025 mm / ±.001"		A ±0.05 mm / ±.002"		H ±0.1 mm / ±.004"		L ±0.1 mm / ±.004"		P ±0.05 mm / ±.002"		T ±0.1 mm / ±.004"		Min. Dist. Hole To Edge	
			mm	in.	mm	in.	mm	in.	mm	in.	mm	in.	mm	in.	mm	in.	mm	in.				
TS4	10	025	0.2 - 0.28	.008 - .011	0.91	.036	1.47	.058	0.99	.039	0.406	.016	2	.079	0.64	.025	1.3	.051	0.25	.010	1	.039
TS4	10	050	0.48 - 0.56	.019 - .022	0.91	.036	1.47	.058	0.99	.039	0.686	.027	2	.079	0.64	.025	1.3	.051	0.25	.010	1	.039

(2) Minimum sheet to prevent protrusion from through hole or minimum blind hole depth.

## CDS™ microPEM® CLAMPDISK® FASTENERS

The CDS™ microPEM® ClampDisk® fastener presses straight onto a 1 mm pin to replace threads, adhesive, rivets and other small fasteners. The upward flanges of the disk grip onto the pin and prevent push-off while the downward flanges flex and generate clamp load.

- Clamp load generation
- Simple installation
- Removability
- Works with multiple panels of any material
- Limited installation stress to assemble
- Tamper resistant

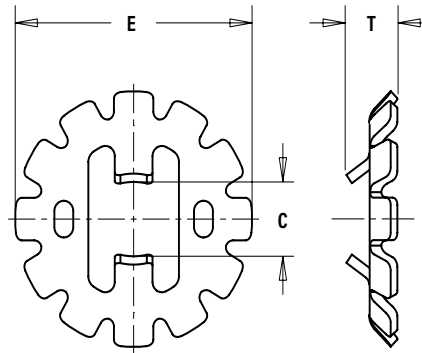
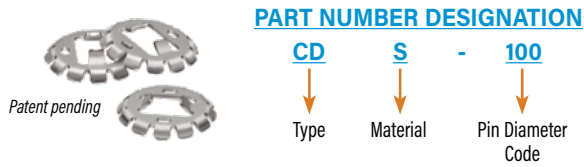

The ClampDisk® fastener can be used with a self-clinching pin. Contact [techsupport@pemnet.com](mailto:techsupport@pemnet.com) for information on pin material options.

All dimensions are in millimeters.

METRIC	Type and Material	Pin Diameter Code	Pin Diameter +0.05 -0.03	Pin Length Min.	C Nom.	E Nom.	T Nom.
	CDS	100	1	0.8	0.91	3.2	0.69

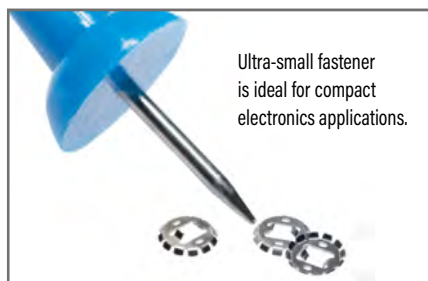
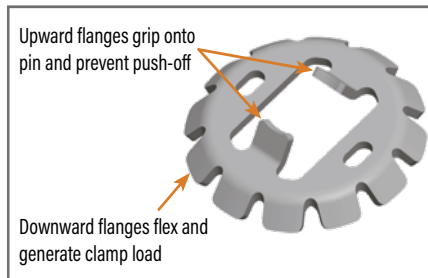
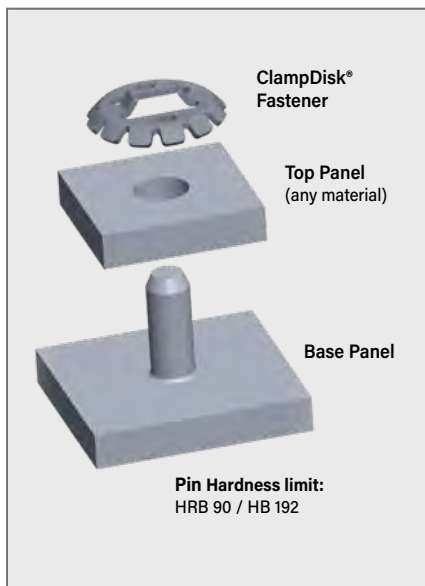

## MSIA™/MSIB™ microPEM® INSERTS FOR PLASTICS

- Symmetrical design eliminates the need for orientation
- Provides excellent performance in wide range of plastics
- Aluminum inserts offer light weight, lead-free alternative

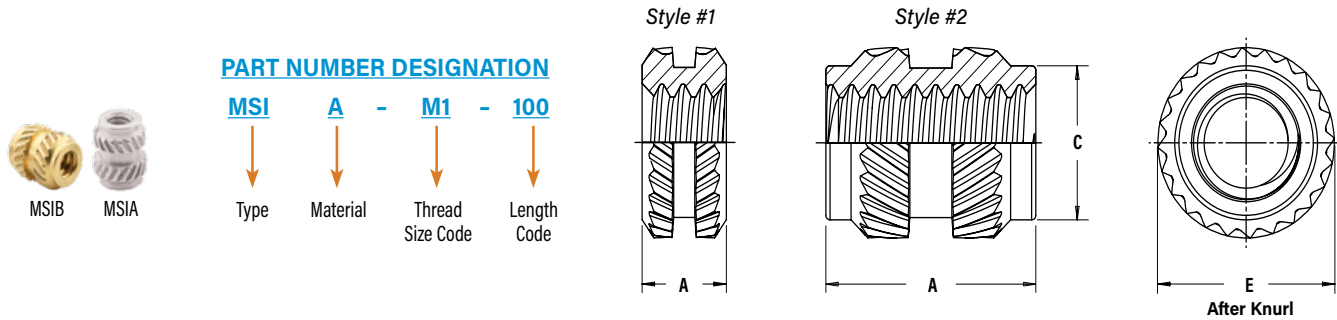

All dimensions are in millimeters.

METRIC	Thread Size x Pitch	Type		Thread Code	Length Code	A ±0.1	E ±0.1	C Max.	Mounting Hole in Material		
		Aluminum	Brass						Min. Wall Thickness (6)	Hole Depth Min.	Hole Diameter +0.05
M1 x 0.25 (3)	MSIA	MSIB	M1	100(1)	1	2.1	—	0.7	1.77	1.75	
				250(2)	2.5		1.75		3.27		
M1.2 x 0.25 (3)	MSIA	MSIB	M1.2	100(1)	1	2.1	—	0.7	1.77	1.75	
				250(2)	2.5		1.75		3.27		
M1.4 x 0.3 (4)	MSIA	MSIB	M1.4	150(2)	1.5	2.5	2.15	0.8	2.27	2.15	
				300(2)	3		2.15		3.77		
M1.6 x 0.35 (5)	MSIA	MSIB	M1.6	150(2)	1.5	2.5	2.15	0.8	2.27	2.15	
				300(2)	3		2.15		3.77		
M2 x 0.4 (5)	MSIA	MSIB	M2	300(2)	3	3.2	2.85	1.6	3.77	2.85	
				400(2)	4		2.85		4.77		

- (1) Style #1 - length codes less than 150  
 (2) Style #2 - length codes 150 and greater  
 (3) Metric ISO 68-1, 5H  
 (4) Metric ISO 68-1, 6H  
 (5) Metric ASME B1.13M, 6H  
 (6) Refers to wall thickness of boss as tested in ABS and polycarbonate.

## MSOFS™ microPEM® FLARING STANDOFFS

- MSOFS™ microPEM® flaring standoffs attach permanently in thin panels of any hardness, including stainless steel
- **No minimum sheet thickness**
- Can be installed into any type or hardness of panel, including metal, plastic and PC board
- Flaring feature allows for captivation of multiple panels
- Fastener captivation method allows for reduced centerline-to-edge designs

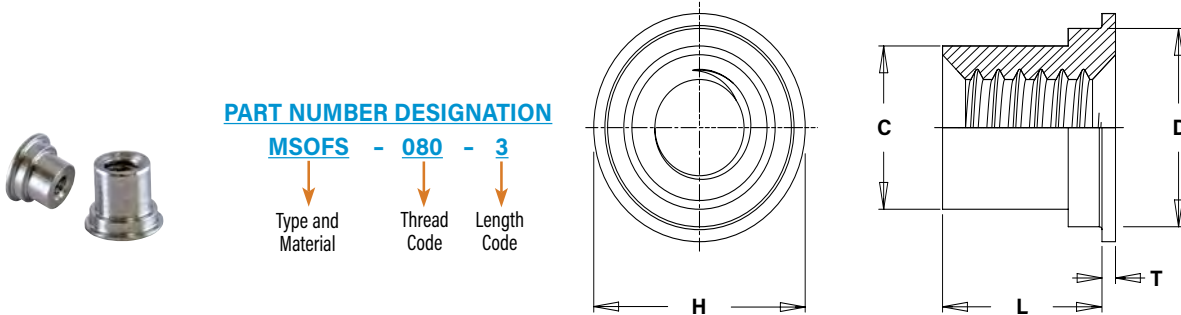

All dimensions are in inches.

UNIFIED	Thread Size	Type	Thread Code	Length Code	Sheet Thickness	Hole Size in Sheet +.002 -.000	C Max.	D Max.	H Nom.	L +.002 -.003	T ±.002	Min. Dist. Hole $\phi$ to Edge
	.060-80 (#0-80) <sup>(1)</sup>	MSOFS	080	3 4	.008 -.012	.118	.094	.117	.138	.093 .125	.010	.069
.086-56 (#2-56) <sup>(1)</sup>	MSOFS	256	3 4	.008 -.012	.138	.113	.137	.157	.093 .125	.010	.079	

All dimensions are in millimeters.

METRIC	Thread Size x Pitch	Type	Thread Code	Length Code	Sheet Thickness	Hole Size in Sheet +0.05	C Max.	D Max.	H Nom.	L +0.05 -0.08	T ±0.05	Min. Dist. Hole $\phi$ to Edge
	M1 x 0.25 <sup>(2)</sup>	MSOFS	M1	2 3	0.2 - 0.3	3	2.39	2.97	3.5	2 3	0.25	1.75
M1.2 x 0.25 <sup>(2)</sup>	MSOFS	M1.2	2 3	0.2 - 0.3	3	2.39	2.97	3.5	2 3	0.25	1.75	
M1.4 x 0.3 <sup>(3)</sup>	MSOFS	M1.4	2 3	0.2 - 0.3	3	2.39	2.97	3.5	2 3	0.25	1.75	
M1.6 x 0.35 <sup>(4)</sup>	MSOFS	M1.6	2 3	0.2 - 0.3	3.5	2.87	3.48	4	2 3	0.25	2	
M2 x 0.4 <sup>(4)</sup>	MSOFS	M2	2 3	0.2 - 0.3	3.5	2.87	3.48	4	2 3	0.25	2	

(1) Internal, ASME B1.1, 2B

(2) Metric ISO 68-1, 5H

(3) Metric ISO 68-1, 6H

(4) Metric ASME B1.13M, 6H

## ALTERNATIVE THIN SHEET CLINCH FASTENER SOLUTIONS

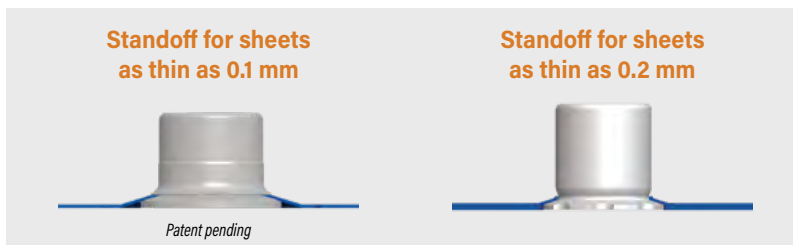

Contact [techsupport@pemnet.com](mailto:techsupport@pemnet.com) for more information.

## SMTSO™ microPEM® SURFACE MOUNT FASTENERS

- Hex shaped barrel provides optimal size/performance
- Provided on tape and reel
- Reduces board handling
- Can be installed automatically

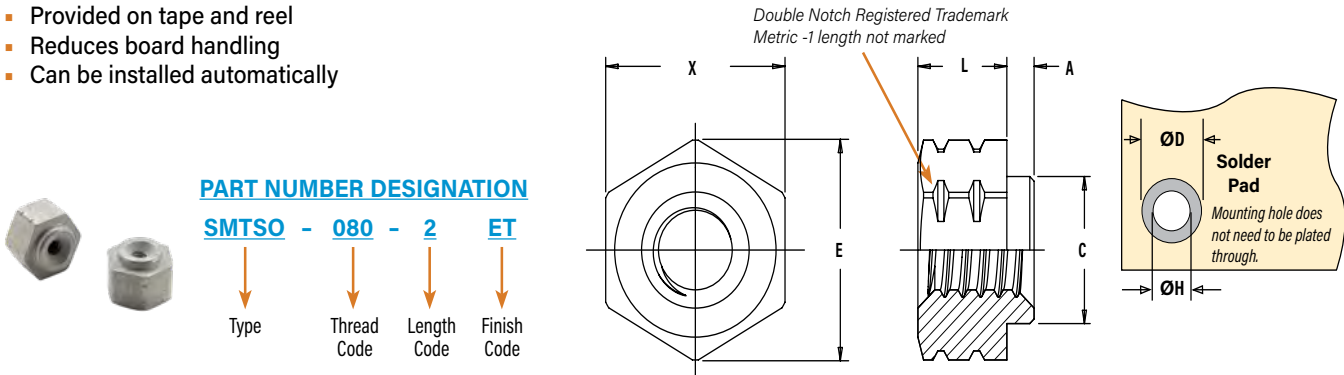

All dimensions are in inches.

UNIFIED	Thread Size	Type	Thread Code	Length Code	Min. Sheet Thickness	A Max.	C Max.	E Ref.	L ±.003	X Nom.	ØH Hole Size In Sheet +.003 -.000	ØD Min. Solder Pad
	.060-80 (#0-80) (1)	SMTSO	080	2 4	.020	.019	.095	.144	.062 .125	.125	.098	.165

All dimensions are in millimeters.

METRIC	Thread Size	Type	Thread Code	Length Code	Min. Sheet Thickness	A Max.	C Max.	E Ref.	L ±0.08	X Nom.	ØH Hole Size In Sheet +0.08	ØD Min. Solder Pad
	S1 (2)	SMTSO	M1		1	0.5	0.48	2.41	3.66	1	3.18	2.5
2					2							
3					3							
S1.2 (2)	SMTSO	M1.2		1	0.5	0.48	2.41	3.66	1	3.18	2.5	4.19
				2					2			
				3					3			
S1.4 (2)	SMTSO	M1.4		1	0.5	0.48	2.41	3.66	1	3.18	2.5	4.19
				2					2			
				3					3			
M1.6 x 0.35 (3)	SMTSO	M1.6		1	0.5	0.48	2.41	3.66	1	3.18	2.5	4.19
				2					2			
				3					3			

(1) Unified ASME B1.1, 2B

(2) Miniature ISO 1501, 4H6

(3) Metric ASME B1.13M, 6H

## NUMBER OF PARTS PER REEL / PITCH (MM) FOR EACH SIZE

Thread/Thru-Hole Size	Length Code							
	1	2	3	4	6	8	10	12
080	—	3500 / 8	—	2000 / 8	—	—	—	—
M1, M1.2, M1.4, M1.6	3500 / 8	2500 / 8	2000 / 8	—	—	—	—	—

A polyimide patch is supplied to allow for reliable vacuum pickup. Fasteners are also available without a patch which may provide a lower cost alternative, depending on your installation methods/requirements.

Packaged on 330 mm recyclable reels. Tape width is 24 mm. Reels conform to EIA-481.



## microPEM® SCREWS (Available on special order. Minimum quantities may apply)

- Smallest thread code: M0.8
- Shortest length: 1 mm / .039"
- Fastener material: steel, stainless steel and aluminum
- Driver types: Torx®/Torx Plus®/Microstix®, cross-recess/internal hex
- Head styles: flat head/pan head/socket-head/wafer-head
- Special features: Locking patch, TAPTITE 2000®, FASTITE 2000®, PT® and DELTA PT®
- Platings: zinc, nickel, black nickel and black oxide

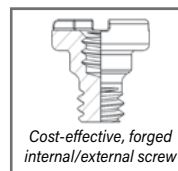

### DELTA PT® SCREWS



- Minimal radial tension due to optimized flank angle
- High clamp load
- High tensile and torsion strength
- Increased cycle stress stability
- High strength under vibration

### REMFORM® SCREWS

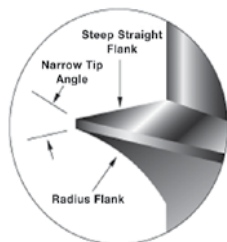

- Designed primarily for plastic applications
- Provides superior performance in a wide range of plastics
- Asymmetrical thread minimizes radial hoop stress to reduce boss bursting
- Narrow tip angle reduces stress in plastic nut member
- Suitable for other ductile materials such as wood and soft metals

### TORX PLUS® DRIVE SYSTEM

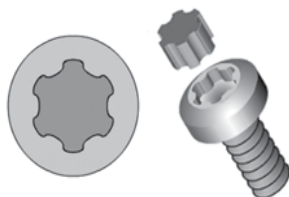

- 0° drive angle
- Elliptical geometric configuration maximizes drive bit engagement
- Large cross-sectional area at lobes
- Vertical sidewalls
- Optimizes torque transfer
- Virtually eliminates cam-out
- Reduces end load and worker fatigue
- Reduces annual drive bit costs

### MICROSTIX® ULTRA-THIN-HEAD PRECISION SCREWS

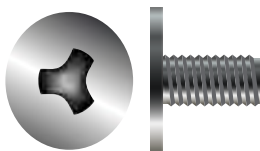

- No cam-out
- No driving force
- High workability
- High torque transmission
- High precision bits
- Tamper proof
- High durability
- Better fit between bits and screws

PennEngineering is a licensee of Acument Global Technologies (Torx®, Torx Plus®), Reminc (REMFORM®, TAPTITE 2000®, FASTITE 2000®), EJOT® (PT® and DELTA PT®) and OSG Corporation and OSG System Products Co., Ltd. (Microstix®).

## MATERIAL AND FINISH SPECIFICATIONS

Type	Fastener Materials							Standard Finishes <sup>(1)</sup>			For Use in Sheet Hardness: <sup>(2)</sup>						
	Carbon Steel	Age Hardened A286 Stainless Steel	300 Series Stainless Steel	Hardened 400 Series Stainless Steel	Hardened Aluminum	Aluminum	Free-Machining Leaded Brass	Passivated and/or Tested Per ASTM A380	Electro-Plated Tin ASTM B 545, Class A, with Clear Preservative Coating, Annealed <sup>(3)</sup>	Plain Finish	HRB 50 / HB 89 or Less	HRB 88 / HB 183 or Less	HRB 92 / HB 202 or Less	PC Board	Plastics	Castings and Brittle Materials	Any Panel Hardness
MPP		▪						▪				▪					
MSO4				▪				▪				▪					
SMTSO	▪								▪				▪				
TA					▪					▪							
T4				▪				▪				▪					
TKA					▪					▪			▪	▪			
TK4				▪				▪					▪	▪	▪		
TFA					▪					▪							
TS4				▪				▪				▪					
CDS			▪					▪									▪ <sup>(4)</sup>
MSIA						▪				▪					▪		
MSIB							▪			▪					▪		
MSOFS			▪					▪									▪
Part Number Codes For Finishes							None	ET	None								

(1) See PEM Technical Support section of our web site for related plating standards and specifications.

(2) HRB - Hardness Rockwell "B" Scale. HB - Hardness Brinell.

(3) Optimal solderability life noted on packaging.

(4) The top panel can be any material and the pin must be under a max hardness of HRB 90 / HB 192.

### A NOTE ABOUT HARDENED 400 SERIES STAINLESS STEEL

In order for self-clinching fasteners to work properly, the fastener must be harder than the sheet into which it is being installed. In the case of stainless steel panels, fasteners made from 300 Series Stainless Steel do not meet this hardness criteria. It is for this reason that 400 series fasteners (MSO4, T4, TK4 and TS4) are offered. However, while these 400 Series fasteners install and perform well in 300 Series stainless sheets they should not be used if the end product:

- Will be exposed to any appreciable corrosive presence
- Requires non-magnetic fasteners
- Will be exposed to any temperatures above 300°F (149°C)

If any of the these are issues, please contact [techsupport@pemnet.com](mailto:techsupport@pemnet.com) for other options.

INSTALLATION

MPP PINS

1. Prepare properly sized mounting hole in sheet. Do not perform any secondary operations such as deburring.
2. Insert pin through mounting hole (preferably the punch side) of sheet and into anvil hole.
3. With installation punch and anvil surfaces parallel, apply squeezing force to embed the head of the pin flush in the sheet.

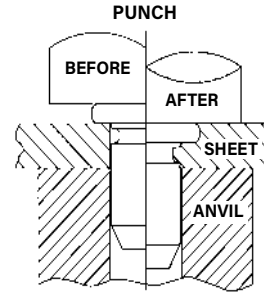

PEMSERTER® Installation Tooling

Type	Pin Diameter Code	Anvil Dimensions (mm)		Anvil Part Number	Punch Part Number
		B ±0.02			
MPP	1MM	1.07		8014168	8014167
MPP	1.5MM	1.57		8014169	8014167
MPP	2MM	2.07		8014170	8014167

Recommended Installation Anvil

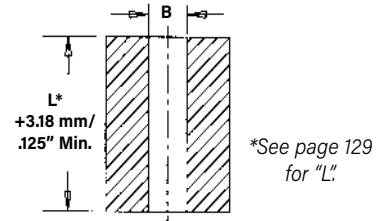

Requirements for Installation into Stainless Steel

1. Sheet hardness must be less than the specified limit for the fastener.
2. Panel material should be in the annealed condition.
3. Fastener should be installed in punch side of hole.
4. Mounting hole punch should be kept sharp to minimize work hardening around hole.
5. Maintain the mounting hole punch diameter to no greater than .025 mm / .001\"/>

MSO4 STANDOFFS

1. Prepare properly sized mounting hole in sheet. Do not perform any secondary operations such as deburring.
2. Insert standoff through mounting hole (preferably the punch side) and into anvil as shown in drawing.
3. With installation punch and anvil surfaces parallel, apply only enough squeezing force to embed the head of the standoff flush in the sheet.

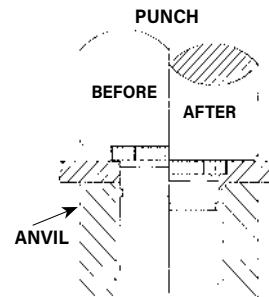

PEMSERTER® Installation Tooling

UNIFIED	Type	Thread Code	Anvil Dimensions (inches)		Anvil Part Number	Punch Part Number
			A	B		
	MSO4	080	.112 - .114	.097 - .099	8015796	975200997
MSO4	256	.142 - .144	.127 - .129	8015797	975200997	

METRIC	Type	Thread Code	Anvil Dimensions (mm)		Anvil Part Number	Punch Part Number
			A	B		
	MSO4	M1	2.84 - 2.89	2.46 - 2.51	8015796	975200997
MSO4	M1.2	2.84 - 2.89	2.46 - 2.51	8015796	975200997	
MSO4	M1.4	2.84 - 2.89	2.46 - 2.51	8015796	975200997	
MSO4	M1.6	2.84 - 2.89	2.46 - 2.51	8015796	975200997	
MSO4	M2	3.6 - 3.65	3.22 - 3.27	8015797	975200997	

Recommended Installation Anvil

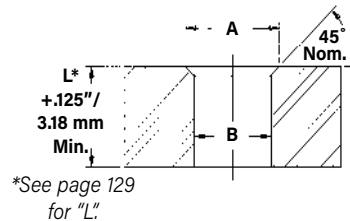

## INSTALLATION

### TA/T4 FASTENERS

1. Prepare properly sized mounting hole in top sheet and base panel. Base panel mounting hole can be through or blind.
2. Place top sheet and base panel in proper position.
3. Place fastener through hole in top sheet and into mounting hole (preferably the punch side) of base panel.
4. With installation punch and anvil surfaces parallel, apply squeezing force until the head of the fastener contacts the top sheet.

#### PEMSERTER® Installation Tooling

Size	Manual Punch Part Number	Manual Anvil Part Number
TA/T4-10-025	8014167	975200046
TA/T4-10-050		
TA/T4-10-075		

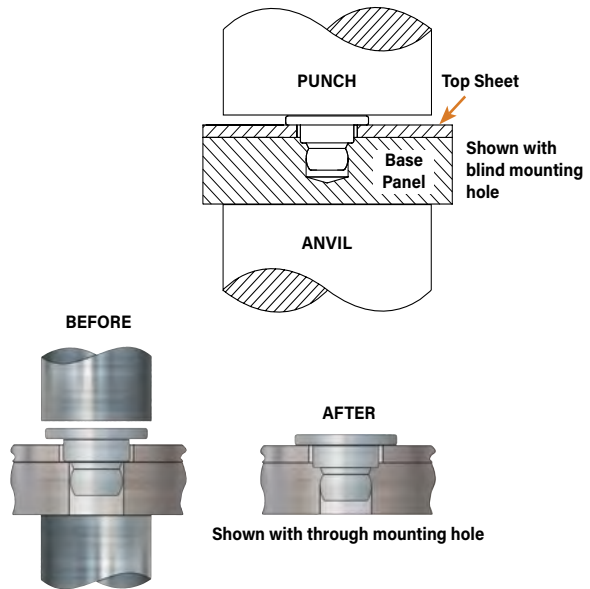

### TKA/TK4 PINS

1. Prepare properly sized mounting hole in top sheet and base panel. Base panel mounting hole can be through or blind.
2. Place top sheet and base panel in proper position.
3. Place pin through hole in top sheet and into mounting hole of base panel.
4. With installation punch and anvil surfaces parallel, apply squeezing force until the head of the pin contacts the top sheet.

#### PEMSERTER® Installation Tooling

Size	Punch Part Number	Anvil Part Number
TKA/TK4-10-100	8014167	975200046
TKA/TK4-10-150		
TKA/TK4-10-200		
TKA/TK4-10-250		
TKA/TK4-10-300		

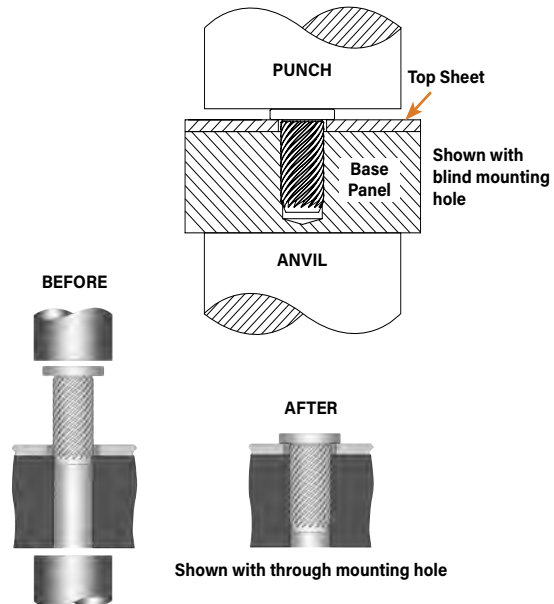

### TFA FASTENERS

1. Prepare properly sized mounting hole in top sheet and base panel. Base panel mounting hole can be through or blind.
2. Place top sheet and base panel in proper position.
3. Place fastener through hole in top sheet and into mounting hole (preferably the punch side) of base panel.
4. With installation punch and anvil surfaces parallel, apply squeezing force until the head of the fastener flattens and contacts the top sheet.

#### PEMSERTER® Installation Tooling

Size	Manual Punch Part Number	Manual Anvil Part Number
TFA-10-025	8014167	975200046
TFA-10-035		
TFA-10-045		
TFA-10-055		

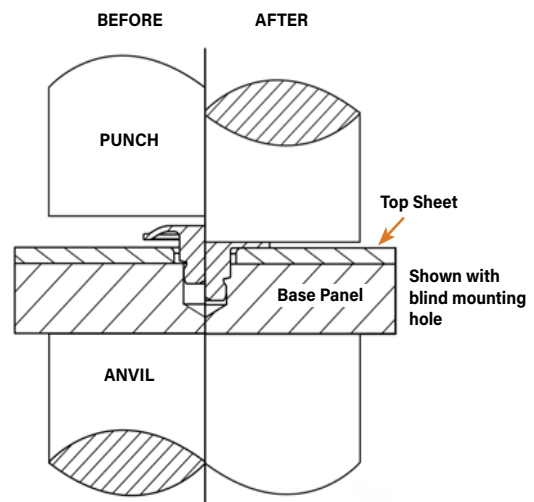

## INSTALLATION

### TS4 FASTENERS

1. Prepare properly sized mounting hole in top sheet and base panel. Base panel mounting hole can be through or blind.
2. Place sheet and base panel in proper position.
3. Place fastener through hole in sheet and into mounting hole (preferably the punch side) of base panel.
4. With punch and anvil surfaces parallel, apply squeezing force until the head of the fastener contacts the top sheet.

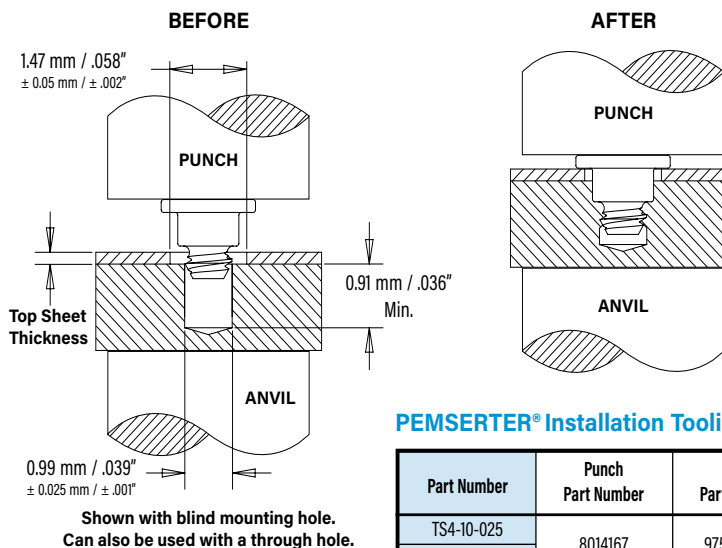

### PEMSERTER® Installation Tooling

Part Number	Punch Part Number	Anvil Part Number
TS4-10-025	8014167	975200046
TS4-10-050		

### Re-installation (if necessary)

1. Place sheet and base panel in proper position.
2. Place adhesive into base panel mounting hole.
3. Place fastener through hole in top sheet and into mounting hole of base panel.
4. Screw in fastener with 2IP Torx Plus driver.

### CDS FASTENERS

1. Place ClampDisk® fastener over a pin.
2. With the installation punch and anvil surfaces parallel, apply squeezing force until the punch contacts the mounting sheet. The drawings at the right indicate suggested tooling for applying these forces.

### Removal

For service or maintenance, the ClampDisk® fastener can be easily removed with a sharp edge tool. For reassembly, simply install a new fastener.

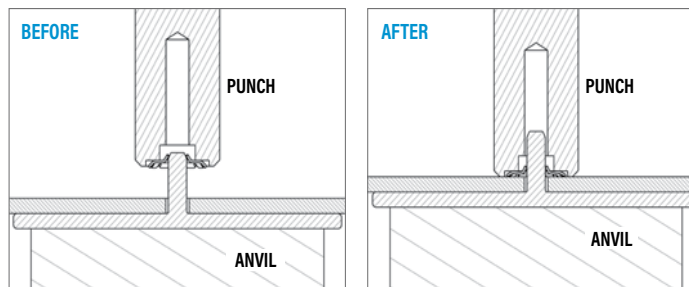

### Installation Tooling

Fastener Part Number	Punch Part Number	Anvil Part Number
CDS-100	8025386	975200046

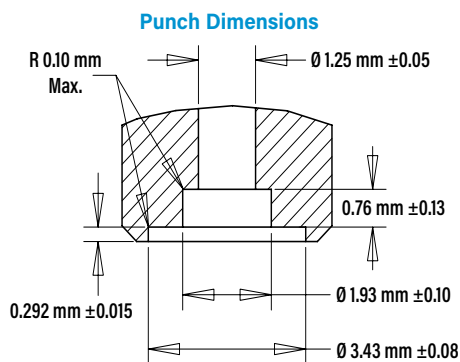

The PEM® ClampDisk® fastener can be installed onto a grooved pin for increase strength and allow installation onto any material. For more information, contact [techsupport@pemnet.com](mailto:techsupport@pemnet.com).

## MSOFS STANDOFFS

1. Prepare properly sized mounting hole in sheet. Do not perform any secondary operations such as deburring.
2. Place the standoff into anvil recess and place the mounting hole over the standoff as shown in the drawing.
3. Using a punch flaring tool and a recessed anvil, apply squeezing force until punch contacts the sheet.

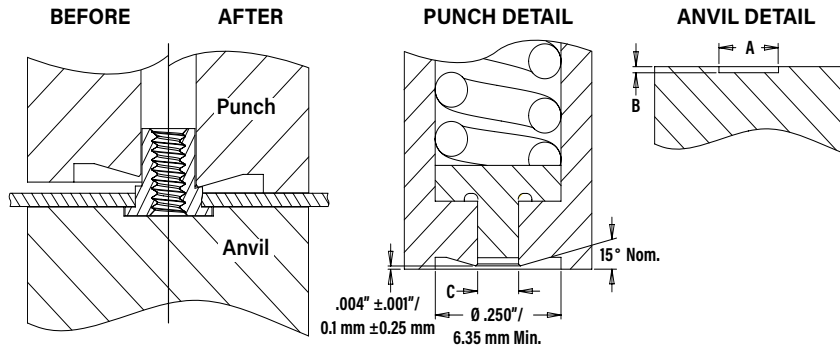

## PEMSERTER® Installation Tooling

UNIFIED	Thread Code	Punch Dimensions (in.)	Punch Part Number	Anvil Dimensions (in.)		Anvil Part Number
		C +.001		A ±.001	B ±.001	
	080	.095	8020712	.143	.006	8019720
	256	.114	8020710	.163	.006	8019722

METRIC	Thread Code	Punch Dimensions (mm)	Punch Part Number	Anvil Dimensions (mm)		Anvil Part Number
		C +0.025		A ±.025	B ±.025	
	M1	2.41	8020712	3.64	0.15	8019720
	M1.2	2.41	8020712	3.64	0.15	8019720
	M1.4	2.41	8020712	3.64	0.15	8019720
	M1.6	2.9	8020710	4.14	0.15	8019722
	M2	2.9	8020710	4.14	0.15	8019722

## SMTSO FASTENERS

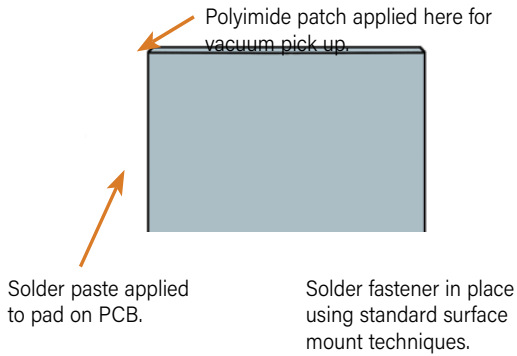

## Number of parts per reel/pitch (mm) for each size

Thread Code	Length Code			
	1	2	3	4
080	—	3500 / 8	—	2000 / 8
M1, M1.2, M1.4, M1.6	3500 / 8	2500 / 8	2000 / 8	—

Packaged on 330mm recyclable reels.  
Tape width is 16mm.  
Supplied with polyimide patch for vacuum pick up.  
Reels conform to EIA-481.

### INSTALLATION NOTES

- For best results we recommend using a Haeger® or PEMSERTER® machine for installation of PEM self-clinching fasteners. Please check our website for more information.
- Visit the Animation Library on our website to view the installation process [for select products](#).

PERFORMANCE DATA<sup>(1)</sup>

MSO4 STANDOFFS

UNIFIED	Type	Thread Code	Max. Rec. Tightening Torque For Mating Screw (in. lbs.)	Sheet Thickness (in.)	Test Sheet Material			
					300 Series Stainless Steel			
					Installation (lbs.)	Pushout (lbs.)	Torque-out (in.lbs.) (2)	Pull-thru (lbs.) (2)
MSO4	080	.65	.013	2500	33	1.3	78	
				.017	2500	45		2.2
MSO4	256	1.3	.013	2500	33	2.2	110	
				.017	2500	45		2.6

METRIC	Type	Thread Code	Max. Rec. Tightening Torque For Mating Screw (N-m)	Sheet Thickness (mm)	Test Sheet Material			
					300 Series Stainless Steel			
					Installation (kN)	Pushout (N)	Torque-out (N-m) (2)	Pull-thru (N) (2)
MSO4	M1	0.019	0.3	11.1	150	0.15	350	
				0.43	11.1	200		0.25
MSO4	M1.2	0.036	0.3	11.1	150	0.15	350	
				0.43	11.1	200		0.25
MSO4	M1.4	0.057	0.3	11.1	150	0.15	350	
				0.43	11.1	200		0.25
MSO4	M1.6	0.084	0.3	11.1	150	0.15	350	
				0.43	11.1	200		0.25
MSO4	M2	0.175	0.3	11.1	150	0.25	500	
				0.43	11.1	200		0.3

TKA/TK4 PINS

Type	Test Base Panel Material	Depth Of Engagement		Installation		Pullout	
		(mm)	(in.)	(N)	(lbs.)	(N)	(lbs.)
TKA-10	ABS	0.8	0.0315	133	30	9	2
		1	0.0394	133	30	14	3
		1.3	0.0492	133	30	19	4
		1.5	0.0590	178	40	24	6
		1.8	0.0708	178	40	31	7
		2	0.0787	222	50	35	8
TKA-10	Polycarbonate	0.8	0.0315	222	50	25	6
		1	0.0394	267	60	37	8
		1.3	0.0492	267	60	53	12
		1.5	0.0590	311	70	68	15
		1.8	0.0708	334	75	86	19
		2	0.0787	378	85	98	22
TK4-10	Magnesium Casting (AZ91D)	0.8	0.0315	445	100	29	7
		1	0.0394	489	110	43	10
		1.3	0.0492	534	120	61	14
		1.5	0.0590	578	130	78	18
		1.8	0.0708	623	140	99	22
		2	0.0787	667	150	113	25
		2.3	0.0886	712	160	131	29
		2.8	0.1102	801	180	169	38

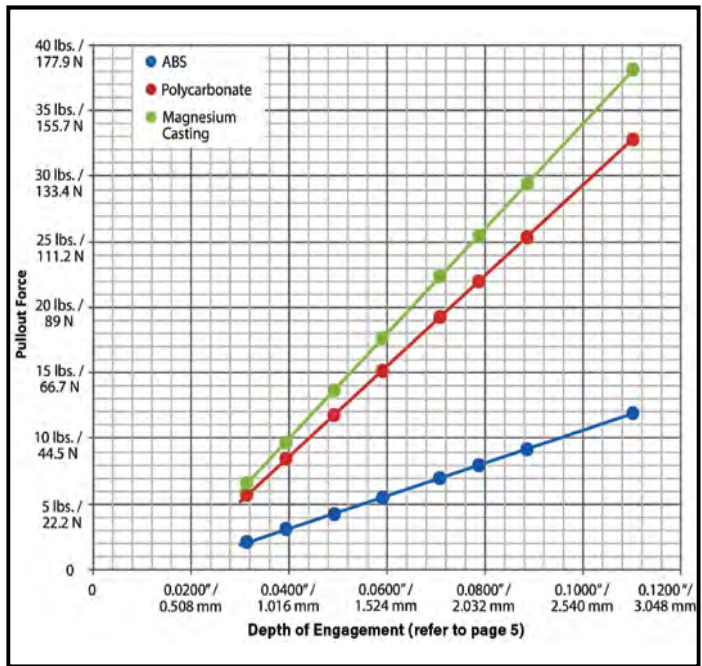

TS4 FASTENERS

Part Number	Tested Top Sheet Thickness	5052-H34 Aluminum HRB 63 / HB 114						304 Stainless Steel HRB 89 / HB 187					
		Installation		Pullout <sup>(3)</sup>		Torque to Remove		Installation		Pullout <sup>(3)</sup>		Torque to Remove	
		(N)	(lbs.)	(N)	(lbs.)	(N-cm)	(in. oz.)	(N)	(lbs.)	(N)	(lbs.)	(N-cm)	(in. oz.)
TS4-10-025	0.254 mm / .01"	556	125	80	18	3.3	4.7	1423	320	125	28	4.6	6.5
TS4-10-050	0.533 mm / .021"												

- (1) Published installation forces are for general reference. Actual set-up and confirmation of complete installation should be made by observing proper seating of fastener as described in the installation steps. Other performance values reported are averages when all proper installation parameters and procedures are followed. Variations in mounting hole size, sheet material, and installation procedure may affect performance. Performance testing this product in your application is recommended. We will be happy to provide technical assistance and/or samples for this purpose.
- (2) Performance in torque-out and pull-thru will depend on the strength and type of screw being used. In most cases the failure will be in the screw and not in the self clinching standoff. Please contact our Applications Engineering group with any questions.
- (3) Pullout after initial installation.



# SELF-LOCKING FASTENERS

## PERFORMANCE DATA

### TFA FASTENERS

Type	5052-H34 Aluminum			
	Installation		Pullout	
	N	lbs.	N	lbs.
TFA-10-025	450	101	40	9
TFA-10-035				
TFA-10-045				
TFA-10-055				

### CDS FASTENERS<sup>(1)</sup>

Part Number	Test Pin Material	Installation (kN) <sup>(1)</sup>	Pull-off (N)	Clamp Load (N)
CDS-100	6061-T6 Aluminum	0.33	18.1	7

### MSOFS STANDOFFS

UNIFIED	Type	Thread Code	Max. Rec. Tightening Torque For Mating Screw (in. lbs.)	Test Sheet Material		
				.008" 300 Series Stainless Steel		
				Installation (lbs.)	Pushout (lbs.)	Torque-out (in.lbs.) <sup>(2)</sup>
MSOFS	080	.65	1500	69.8	1.29	
MSOFS	256	1.3	1800	91.2	1.29	

METRIC	Type	Thread Code	Max. Rec. Tightening Torque For Mating Screw (N-m)	Test Sheet Material		
				0.2 mm 300 Series Stainless Steel		
				Installation (kN)	Pushout (N)	Torque-out (N-m) <sup>(2)</sup>
MSOFS	M1	0.019	6.67	311	0.146	
MSOFS	M1.2	0.036	6.67	311	0.146	
MSOFS	M1.4	0.057	6.67	311	0.146	
MSOFS	M1.6	0.084	8	406	0.146	
MSOFS	M2	0.175	8	406	0.146	

### MSIA/MSIB INSERTS

METRIC	Type	Thread Code	Length Code	Test Sheet Material			
				ABS		Polycarbonate	
				Pullout (N)	Torque-out (N-cm) <sup>(2)</sup>	Pullout (N)	Torque-out (N-cm) <sup>(2)</sup>
MSIA/MSIB	M1		100	50	3.5	50	4.5
			250	150	10	200	12
MSIA/MSIB	M1.2		100	50	3.5	50	4.5
			250	150	10	200	12
MSIA/MSIB	M1.4		150	100	15	140	15
			300	330	30	400	30
MSIA/MSIB	M1.6		150	100	15	140	15
			300	330	30	400	30
MSIA/MSIB	M2		300	335	35	410	33
			400	470	40	595	35

For testing purposes, inserts were installed using heat stake equipment into a flat sheet.

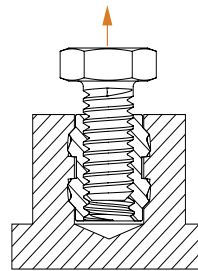

**Pullout** is the force required to pull the insert from the sheet.

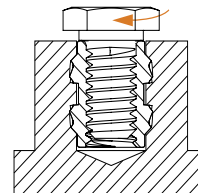

**Torque-out** is the torque required to turn the insert in the parent material after installation without inducing clamp load on the fastener.

### HOLE PREPARATION GUIDELINES

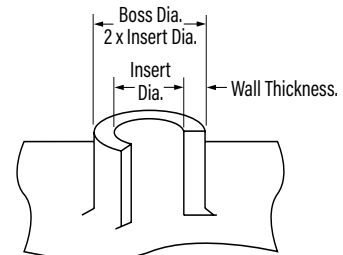

Thinner walls and bosses may be used but will affect performance.

### SMTSO<sup>(3)(4)</sup> FASTENERS

Type and Size	Test Sheet Material			
	.062" Single Layer RF-4			
	Pushout (lbs.)	Pushout (N)	Torque-out (in. lbs.)	Torque-out (N-m)
SMTSO-080	85.1	378.7	4.94	0.56
SMTSO-M1				
SMTSO-M1.2				
SMTSO-M1.4				
SMTSO-M1.6				

### SMTSO TESTING CONDITIONS

Oven	Quad ZCR convection oven with 4 zones
High Temp	518° F / 270° C
Board Finish	62% Sn, 38% Pb
Screen Printer	Ragin Manual Printer
Vias	None
Spokes	2 Spoke Pattern
Paste (lead-free)	Amtech NC559LF Sn96.5/3.0Ag/0.5Cu (SAC305)
Stencil	.0067" / 0.17mm thick

- (1) Specially designed installation punch prevents over-installation and damage to the fastener.
- (2) Torque-out performance will depend on the strength and type of screw being used. In most cases, the screw threads will fail before the insert threads.
- (3) With lead-free paste. Average values of 30 test points. The data presented here is for general comparison purposes only. Actual performance is dependent upon application variables. We will be happy to provide samples for you to install. If required, we can also test your installed hardware and provide you with the performance data specific to your application.
- (4) Further testing details can be found in our web site's literature section.



PEM® captive hardware for easy service access without loose components.



**PF™**

**PEM® CAPTIVE  
PANEL SCREWS**

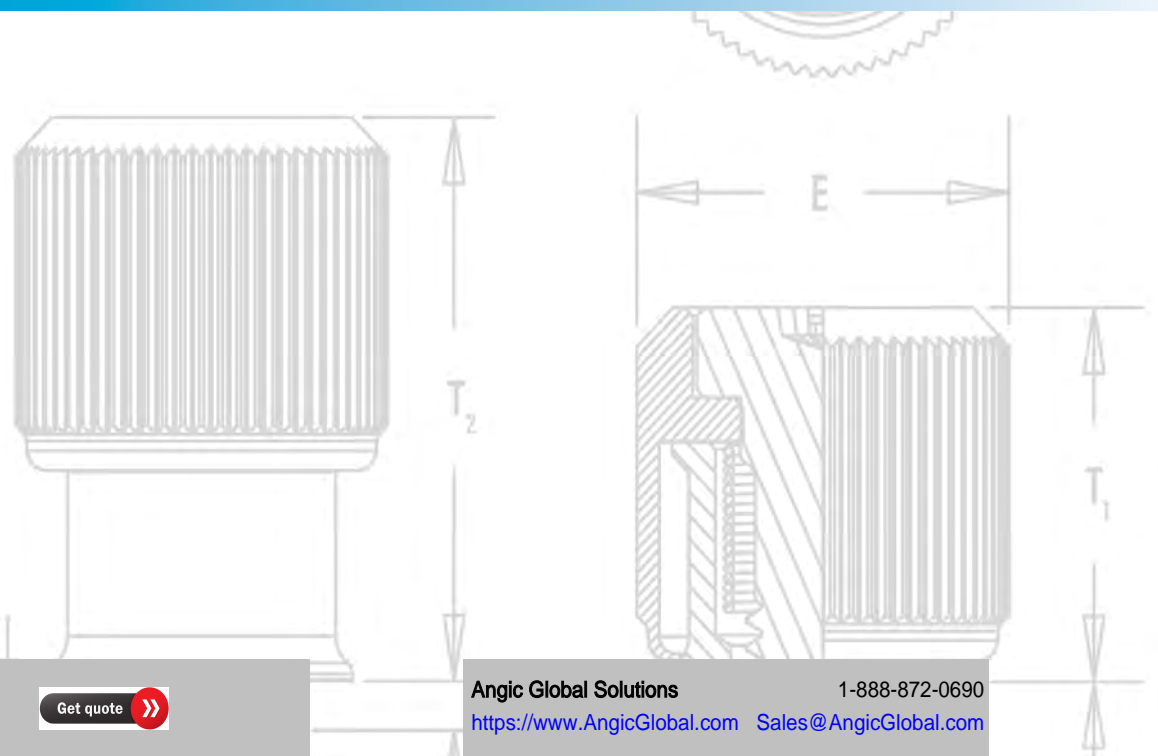

Get quote >>

Angic Global Solutions

1-888-872-0690

<https://www.AngicGlobal.com> [Sales@AngicGlobal.com](mailto:Sales@AngicGlobal.com)

# PEM® CAPTIVE PANEL SCREWS

PEM® brand captive panel screws are designed to help keep parts to a minimum and eliminate risks associated with loose hardware that could fall out and damage internal components. These panel fastener assemblies are ideal to attach metal panels or other thin material components in applications where subsequent access will be necessary.

PF11™/PF12™/PF11M™/PF12M™/PF15™/PF15M™ large knob, spring-loaded self-clinching panel screws - <b>PAGE 149</b>		PFC2™/PFS2™ screw head, spring-loaded captive panel screws - <b>PAGE 160</b>	
PF11MF™ large knob, spring-loaded flare-mounted captive panel screws - <b>PAGE 150</b>		PTL2™/PSL2™ locating pin, spring-loaded plunger assemblies - <b>PAGE 161</b>	
PF11MW™ large knob, spring-loaded flare-mounted, floating captive panel screws - <b>PAGE 151</b>		SCBR™ tool only, spinning clinch bolt with spring - <b>PAGE 162</b>	
PF11PM™ large knob, spring-loaded plastic PEM® C.A.P.S.® captive panel screws - <b>PAGE 152</b>		SCB™/SCBJ™ tool only, spinning clinch bolts, no spring - <b>PAGE 163</b>	
PFHV™ screw, non-spring captive panel screw - <b>PAGE 153</b>		HSCB™, HSR™, and HSL™ heat sink mounting fastener system - <b>PAGES 164 - 165</b>	
PF7M™ captive panel screw, spring-loaded self-clinching captive panel screws - <b>PAGE 154</b>		PF10™ tool only, flush-mounted captive panel screws, no spring - <b>PAGES 166 - 167</b>	
PF7MF™ spring-loaded, flare-mounted captive panel screw - <b>PAGE 155</b>		REELFAST® SMTPLSM™ surface mount spring-loaded captive panel screws - <b>PAGE 168</b>	
PF30™ low-profile knob, spring-loaded captive panel screws - <b>PAGE 156</b>		REELFAST® SMTPF™ surface mount, panel screw components - <b>PAGE 169</b>	
PF50™ and PF60™ low-profile knob, spring-loaded captive panel screws - <b>PAGE 157</b>		PFK™ screw head, spring-loaded broaching captive panel screws - <b>PAGE 170</b>	
PFC4™ recessed-head captive panel screws for installing into stainless steel - <b>PAGE 158</b>		Value-added capabilities - <b>PAGE 171</b>	
		Captive panel screw installation - <b>PAGES 172 - 180</b>	
PFC2P™ tool only, non-flush, spring-loaded captive panel screws - <b>PAGE 159</b>		Captive panel screw performance data - <b>PAGES 181 - 185</b>	
		Captive panel screw capabilities - <b>PAGE 186</b>	

## HEIGHT COMPARISON GUIDE AND STANDARD DRIVER RECESS

Installed and fastened height above sheet for M3 Thread size.

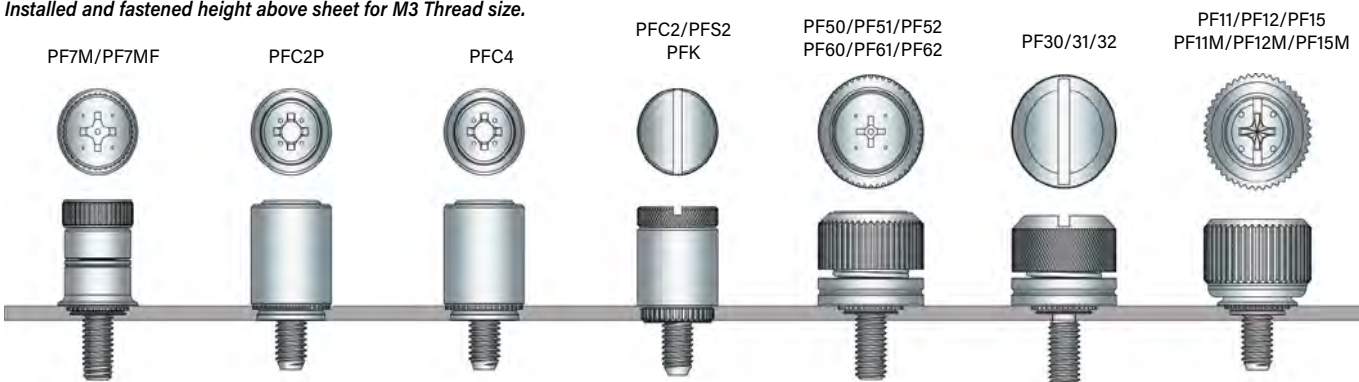

# PEM® CAPTIVE PANEL SCREWS

## CAPTIVE PANEL SCREW SELECTOR GUIDE

PEM® Panel Fastener Type	Page No.	Application Requires:														
		UL Approved	High corrosion resistance	Spring loaded	Actuation		Installs into				Multiple screw lengths	Flush mounted top side	Available in black	Available in custom colors	Includes anti cross-threading feature	Mating hole misalignment
					Tool	Hand	Thinner sheets	Printed circuit boards	Stainless steel sheet	Painted panels and/or any hardness						
PF11/PF15	149			*	*	*					*		*			
PF11M/PF15M	149			*	*	*					*		*		*	
PF12	149			*	*						*		*			
PF12M	149			*	*						*		*		*	
PF11MF	150			*	*	*	*		*	*	*		*		*	
PF12MF	150			*	*		*		*	*	*		*		*	
PF11MW	151			*	*	*	*	*	*	*	*		*		*	*
PF12MW	151			*	*		*	*	*	*	*		*		*	*
PEM C.A.P.S.	152			*	*	*					*		.(1)	*	*	
PFHV	153				*						*		*		*	
PF7M	154			*	*	*					*		*		*	
PF7MF	155			*	*	*	*		*	*	*		*		*	
PF30	156			*	*	*							*			
PF31				*	*	*							*			
PF32				*	*	*							*			
PF50	157			*	*	*					*		*			
PF51				*	*	*					*		*			
PF52				*	*	*					*		*			
PF60	157			*	*						*		*			
PF61				*	*						*		*			
PF62				*	*						*		*			
PFC4	158	*		*	*				*		*		*			
PFC2P	159	*		*	*						*		*			
PFC2	160		*	*	*	*					*		*			
PFS2	160			*	*	*					*		*			
SCBR	162			*	*						*		*			
SCB/SCBJ	163				*						*		*			
HSCB	164-165			*	*						*		*			
PF10	166-167	*	*		*						*		*			
SMTPF LSM	168			*	*	*			*		*		*		*	
SMTPF	169				*	*			*		*		.(1)	*		
PFK	170		*	*	*	*			*		*		*			

(1) Standard color is black.

PF11MF

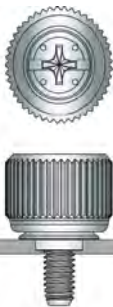

PF11MW

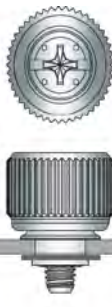

PEM C.A.P.S.®



HSCB



PFHV



SCBR



SCB/SCBJ



PF10



Get quote »

Angic Global Solutions

1-888-872-0690 [et.com](https://www.AngicGlobal.com) 147

<https://www.AngicGlobal.com> Sales@AngicGlobal.com

# PEM® CAPTIVE PANEL SCREWS

## PEM® PF11™, PF12™, PF15™, PF11MF™, PF11MW™, AND PEM® C.A.P.S.® CAPTIVE PANEL SCREWS

- Available in three installation types; self-clinching, flare-mounted and floating
- All have the same profile or look above the sheet or panel
- Standard selection of knobs include knurled, semi-smooth or smooth metal caps and plastic PEM C.A.P.S.® (Colored Access Panel Screws)

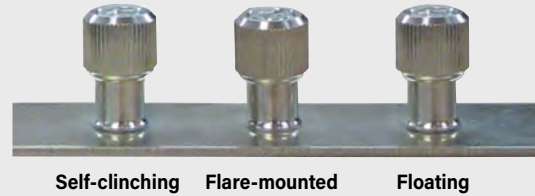

### Key Features Include:

- Shoulder on retainer to provide positive stop during installation.
- Anti cross-threading feature (designated with an "M" in the part number). Eases assembly, aligns components, improves assembly line productivity, prevents jamming, and slides through clogged internal threads.

#### Shoulder on Retainer



#### Anti Cross-thread Technology - How it works

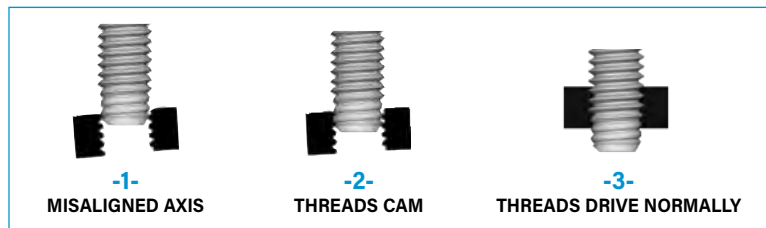

*PennEngineering is a licensee for MATHread® technology, a registered trademark of MATHread Inc.*

### Standard Mounting Styles:

#### Self-clinching

- Installs flush on back side of panel.
- Available in three screw lengths.



#### Flare-mounted

- Appropriate for close centerline-to-edge applications.
- Doesn't require high installation force.
- Installs into any panel hardness.
- Installs flush on back side of panel.
- Can be installed into most any thin material.
- Appropriate for painted panels.



#### Flare-mounted, Floating

- Compensates for mating hole misalignment.
- Installs into any panel hardness.



### Standard Cap Selection:



**Knurled Metal Cap**  
All metal cap available with knurls.



**Smooth Metal Cap**  
All metal cap available without knurls.



**Semi-smooth Metal Cap**  
All metal cap available with partial knurls.



**Black Metal Cap**  
DuraBlack™ finish is scratch resistant. Finish is on both metal cap and screw. (finish code "BL")



**Plastic Cap**  
Available with custom color plastic cap. (See page 8 for colors)

### Available Drive Configurations:

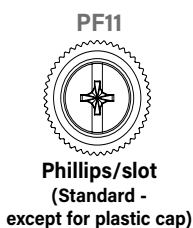

*PennEngineering is a licensee for Acument Global Technologies (Torx®).*

# PEM® CAPTIVE PANEL SCREWS

## PF11™/PF12™/PF15™ CAPTIVE PANEL SCREWS

**NEW**



New semi-smooth cap design reduces scratches

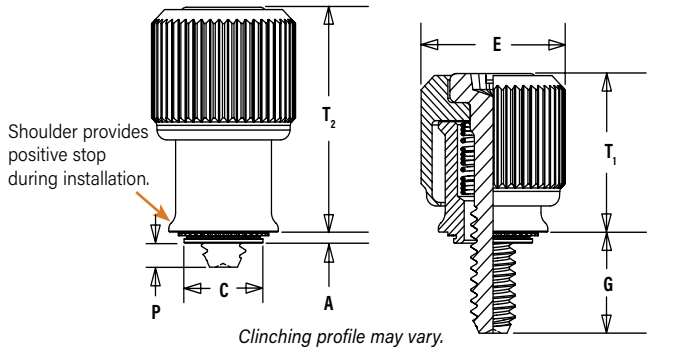

Float .010"/0.25mm minimum, in all directions from center, .020"/0.5mm total.

Installation Data page 172. Performance Data page 181.

<b>Threads:</b> External, ASME B1.1, 2A / ASME B1.13M, 6g
<b>Material:</b> Knob: Aluminum Retainer: Hardened Carbon Steel Screw (PF11/PF12/PF15): 400 Series Stainless Steel Screw (PF11M/PF12M/PF15M): Hardened Carbon Steel <sup>(1)</sup> Spring: 300 Series Stainless Steel
<b>Finish:</b> Knob: Natural Finish Retainer: Bright nickel over copper flash, per ASTM B689, Type II Screw (PF11/PF12/PF15): Passivated and/or tested per ASTM A380 Screw: (PF11M/PF12M/PF15M): Zinc plated per ASTM B633, SC1 (5µm), Type III, colorless <sup>(3)</sup> Spring: Natural Finish
<b>Optional Finish (BL):</b> Knob: Black anodize <sup>(2)</sup> Screw: Black nitride, AMS2753, Section 3 <sup>(2)</sup>
<b>For use in sheet hardness:</b> HRB 80 or less (Hardness Rockwell "B" Scale) / HB 150 or less (Hardness Brinell)

### PART NUMBER DESIGNATION

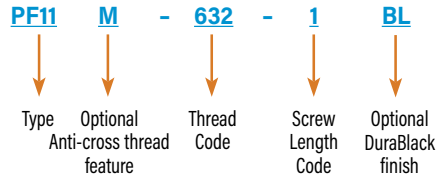

All dimensions are in inches.

UNIFIED	Thread Size	Type			Thread Code	Screw Length Code	A Max.	Min. Sheet Thickness	Hole Size In Sheet + .003 - .000	C Max.	E ± .010	G ± .025	P ± .025	T <sub>1</sub> Nom.	T <sub>2</sub> Nom.	Driver Size	Min. Dist. Hole To Edge		
		Knurled Cap	Smooth Cap	Semi-smooth Cap															
.112-40 (#4-40)	PF11 PF11M	PF12 PF12M	PF15 PF15M	440	0	.036	.036	.219	.218	.417	.170	.000	.310	.450	#1	.28			
																	1	.230	.060
																	2	.290	.120
.138-32 (#6-32)	PF11 PF11M	PF12 PF12M	PF15 PF15M	632	0	.036	.036	.250	.249	.450	.230	.000	.450	.640	#2	.29			
																	1	.290	.060
																	2	.350	.120
.164-32 (#8-32)	PF11 PF11M	PF12 PF12M	PF15 PF15M	832	0	.036	.036	.312	.311	.514	.230	.000	.450	.640	#2	.33			
																	1	.290	.060
																	2	.350	.120
.190-32 (#10-32)	PF11 PF11M	PF12 PF12M	PF15 PF15M	032	0	.036	.036	.312	.311	.514	.230	.000	.450	.640	#2	.33			
																	1	.290	.060
																	2	.350	.120
.250-20 (1/4-20)	PF11 PF11M	PF12 PF12M	PF15 PF15M	0420	0	.036	.036	.375	.374	.575	.290	.000	.530	.790	#3	.46			
																	1	.350	.060
																	2	.410	.120

All dimensions are in millimeters.

METRIC	Thread Size x Pitch	Type			Thread Code	Screw Length Code	A Max.	Min. Sheet Thickness	Hole Size In Sheet + 0.08	C Max.	E ± 0.25	G ± 0.64	P ± 0.64	T <sub>1</sub> Nom.	T <sub>2</sub> Nom.	Driver Size	Min. Dist. Hole To Edge		
		Knurled Cap	Smooth Cap	Semi-smooth Cap															
M3 x 0.5	PF11 PF11M	PF12 PF12M	PF15 PF15M	M3	0	0.92	0.92	5.56	5.54	10.59	4.32	0	787	11.43	#1	711			
																	1	5.84	1.52
																	2	7.37	3.05
M3.5 x 0.6	PF11 PF11M	PF12 PF12M	PF15 PF15M	M3.5	0	0.92	0.92	6.35	6.33	11.43	5.84	0	11.43	16.26	#2	737			
																	1	7.37	1.52
																	2	8.89	3.05
M4 x 0.7	PF11 PF11M	PF12 PF12M	PF15 PF15M	M4	0	0.92	0.92	7.92	7.9	13.06	5.84	0	11.43	16.26	#2	838			
																	1	7.37	1.52
																	2	8.89	3.05
M5 x 0.8	PF11 PF11M	PF12 PF12M	PF15 PF15M	M5	0	0.92	0.92	7.92	7.9	13.06	5.84	0	11.43	16.26	#2	838			
																	1	7.37	1.52
																	2	8.89	3.05
M6 x 1	PF11 PF11M	PF12 PF12M	PF15 PF15M	M6	0	0.92	0.92	9.53	9.5	14.61	7.37	0	13.46	20.07	#3	1168			
																	1	8.89	1.52
																	2	10.41	3.05

(1) As with all Class 2A/6g external threads with an additive finish, the maximum major and pitch, after plating, may equal basic sizes and be gauged to Class 3A/4h, per ANSI B1.1, Section 8, Table 3A and ANSI B1.13M, Section 8, Paragraph 8.2.

(2) "BL" suffix will be added to part number to designate DuraBlack™ finish.

(3) See PEM Technical Support section of our website ([www.pemnet.com](http://www.pemnet.com)) for related plating standards and specifications.



Get quote >>

Angic Global Solutions

1-888-872-0690 [www.angic.com](http://www.angic.com) 149

<https://www.AngicGlobal.com> Sales@AngicGlobal.com

# PEM® CAPTIVE PANEL SCREWS

## PFMF™ FLARE-MOUNTED CAPTIVE PANEL SCREWS



**PF11MF**  
Knurled Cap



**PF12MF**  
Smooth Cap

Dimples on head designate metric thread.

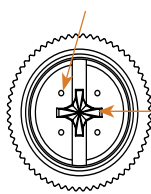

Phillips driver size. (See chart)

<b>Threads:</b> External, ASME B1.1, 2A / ASME B1.13M, 6g <sup>(1)</sup>
<b>Material:</b> Knob: Aluminum Retainer: Aluminum Screw: Hardened Carbon Steel Spring: 300 Series Stainless Steel
<b>Finish:</b> Knob: Natural Finish Retainer: Natural Finish Screw: Zinc plated per ASTM B633, SC1 (5µm), Type III, colorless <sup>(3)</sup> Spring: Natural Finish
<b>Optional Finish (BL):</b> Knob: Black anodize <sup>(2)</sup> Screw: Black nitride AMS2753, Section 3 <sup>(2)</sup>

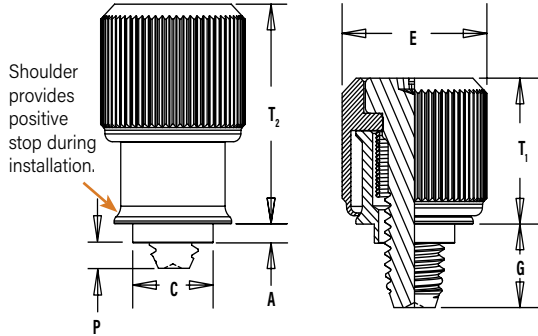

Float .010"/0.25mm minimum, in all directions from center, .020"/0.5mm total.

**Installation Data page 172. Performance Data page 181.**

### PART NUMBER DESIGNATION

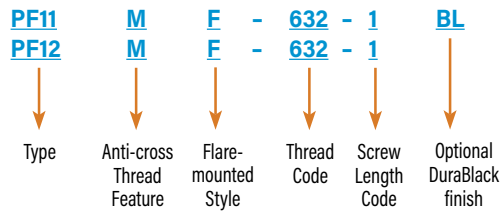

All dimensions are in inches.

UNIFIED	Thread Size	Type		Thread Code	Screw Length Code	A Max.	Min. Sheet Thickness	Countersunk Hole Size In Sheet <sup>(4)</sup> +.005 - .000	C Max.	E ± .010	G ± .025	P ± .025	T <sub>1</sub> Nom.	T <sub>2</sub> Nom.	Driver Size
		Knurled Cap	Smooth Cap												
.112-40 (#4-40)	PF11MF	PF12MF	440	0	.041	.031	.187	.186	.417		.170	.000	.310	.450	#1
											.230	.055			
											.290	.115			
.138-32 (#6-32)	PF11MF	PF12MF	632	0	.072	.060	.213	.212	.450		.230	.000	.450	.640	#2
											.290	.024			
											.350	.084			
.164-32 (#8-32)	PF11MF	PF12MF	832	0	.072	.060	.266	.265	.514		.230	.000	.450	.640	#2
											.290	.024			
											.350	.084			
.190-32 (#10-32)	PF11MF	PF12MF	032	0	.072	.060	.266	.265	.514		.230	.000	.450	.640	#2
											.290	.024			
											.350	.084			
.250-20 (1/4-20)	PF11MF	PF12MF	0420	0	.072	.060	.323	.322	.575		.290	.000	.530	.790	#3
											.350	.024			
											.410	.084			

All dimensions are in millimeters.

METRIC	Thread Size x Pitch	Type		Thread Code	Screw Length Code	A Max.	Min. Sheet Thickness	Countersunk Hole Size In Sheet <sup>(4)</sup> +0.1	C Max.	E ± 0.25	G ± 0.64	P ± 0.64	T <sub>1</sub> Nom.	T <sub>2</sub> Nom.	Driver Size
		Knurled Cap	Smooth Cap												
M3 x 0.5	PF11MF	PF12MF	M3	0	1.05	0.79	4.75	4.73	10.59		4.32	0	7.87	11.43	#1
											5.84	1.4			
											7.37	2.92			
M4 x 0.7	PF11MF	PF12MF	M4	0	1.83	1.52	6.76	6.74	13.06		5.84	0	11.43	16.26	#2
											7.37	0.61			
											8.89	2.13			
M5 x 0.8	PF11MF	PF12MF	M5	0	1.83	1.52	6.76	6.74	13.06		5.84	0	11.43	16.26	#2
											7.37	0.61			
											8.89	2.13			
M6 x 1	PF11MF	PF12MF	M6	0	1.83	1.52	8.2	8.18	14.61		7.37	0	13.46	20.07	#3
											8.89	0.61			
											10.41	2.13			

- (1) As with all Class 2A/6g external threads with an additive finish, the maximum major and pitch, after plating, may equal basic sizes and be gauged to Class 3A/4h, per ANSI B1.1, Section 8, Table 3A and ANSI B1.13M, Section 8, Paragraph 8.2.
- (2) "BL" suffix will be added to part number to designate DuraBlack™ finish.
- (3) See PEM Technical Support section of our website ([www.pemnet.com](http://www.pemnet.com)) for related plating standards and specifications.
- (4) See page 172 for countersunk hole size detail.



# PEM® CAPTIVE PANEL SCREWS

## PFMW™ FLARE-MOUNTED, FLOATING CAPTIVE PANEL SCREWS

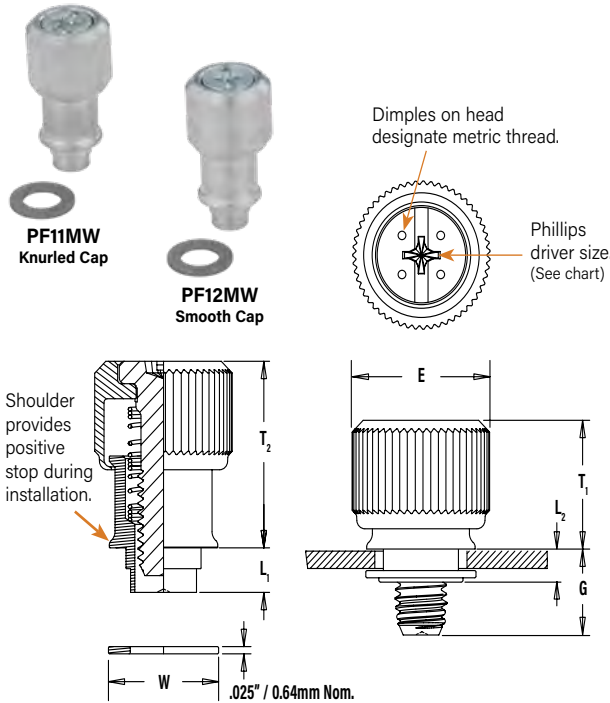

Installation Data page 173. Performance Data page 181.

<b>Threads:</b> External, ASME B1.1, 2A / ASME B1.13M, 6g <sup>(1)</sup>	
<b>Material:</b> Knob: Aluminum Retainer: Aluminum Screw: Hardened Carbon Steel Spring: 300 Series Stainless Steel Washer: 300 Series Stainless Steel	
<b>Finish:</b> Knob: Natural Finish Retainer: Natural Finish Screw: Zinc plated per ASTM B633, SC1 (5µm), Type III, colorless <sup>(3)</sup> Spring: Natural Finish Washer: Natural Finish	<b>Optional Finish (BL):</b> Knob: Black anodize <sup>(2)</sup> Screw: Black nitride, AMS2753, Section 3 <sup>(2)</sup>

### PANEL CONFIGURATION 1

For applications where a space between mating panels is acceptable.

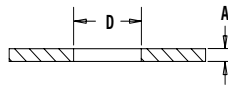

### PANEL CONFIGURATION 2

For applications where a space between mating panels is not acceptable.

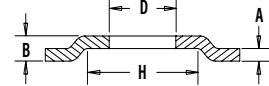

### PART NUMBER DESIGNATION

PF11	M	W - 632 - 1	1	1	BL
PF12	M	W - 632 - 1	1	1	
↓	↓	↓	↓	↓	↓
Type	Anti-cross Thread Feature	Floating style	Thread Code	Shank Code <sup>(4)</sup>	Screw Length Code <sup>(4)</sup>
					Optional DuraBlack finish

PF11MW panel fasteners are shipped with mating washers.

All dimensions are in inches.

UNIFIED	Thread Size	Type		Thread Code	Shank Code (4)	Screw Length Code (4)	A Max. Sheet Thickness	B Min.	D Hole Size In Sheet +.003 -0.01	E ±.010	G Nom.	H Min.	L <sub>1</sub> Nom.	L <sub>2</sub> Max.	T <sub>1</sub> Nom.	T <sub>2</sub> Nom.	Driver Size	Min. Total Float	W Nom.
		Knurled Cap	Smooth Cap																
.112-40 (#4-40)	PF11MW	PF12MW	440	1	1	.063	.111	.250	.417	.230	.290	.375	.137	.127	.310	.450	#1	.073	.312
.138-32 (#6-32)	PF11MW	PF12MW	632	1	1	.063	.115	.283	.450	.290	.350	.413	.149	.127	.450	.640	#2	.076	.344
.164-32 (#8-32)	PF11MW	PF12MW	832	1	1	.063	.121	.346	.514	.290	.350	.469	.157	.140	.450	.640	#2	.076	.407
.190-32 (#10-32)	PF11MW	PF12MW	032	1	1	.063	.121	.346	.514	.290	.350	.469	.157	.140	.450	.640	#2	.076	.407
.250-20 (1/4-20)	PF11MW	PF12MW	0420	1	1	.063	.128	.413	.575	.350	.410	.531	.157	.140	.530	.790	#3	.081	.468

All dimensions are in millimeters.

METRIC	Thread Size x Pitch	Type		Thread Code	Shank Code (4)	Screw Length Code (4)	A Max. Sheet Thickness	B Min.	D Hole Size In Sheet +0.08 -0.03	E ±0.25	G Nom.	H Min.	L <sub>1</sub> Nom.	L <sub>2</sub> Max.	T <sub>1</sub> Nom.	T <sub>2</sub> Nom.	Driver Size	Min. Total Float	W Nom.
		Knurled Cap	Smooth Cap																
M3 x 0.5	PF11MW	PF12MW	M3	1	1	1.6	2.82	6.35	10.59	5.84	7.37	9.52	3.48	3.23	7.87	11.43	#1	1.85	7.92
M3.5 x 0.6	PF11MW	PF12MW	M3.5	1	1	1.6	2.92	7.19	11.43	7.37	8.89	10.49	3.78	3.23	11.43	16.26	#2	1.93	8.74
M4 x 0.7	PF11MW	PF12MW	M4	1	1	1.6	3.07	8.79	13.06	7.37	8.89	11.91	3.99	3.56	11.43	16.26	#2	1.93	10.34
M5 x 0.8	PF11MW	PF12MW	M5	1	1	1.6	3.07	8.79	13.06	7.37	8.89	11.91	3.99	3.56	11.43	16.26	#2	1.93	10.34
M6 x 1	PF11MW	PF12MW	M6	1	1	1.6	3.25	10.49	14.61	8.89	10.41	13.48	3.99	3.56	13.46	20.07	#3	2.06	11.89

- (1) As with all Class 2A/6g external threads with an additive finish, the maximum major and pitch, after plating, may equal basic sizes and be gauged to Class 3A/4h, per ANSI B1.1, Section 8, Table 3A and ANSI B1.13M, Section 8, Paragraph 8.2.
- (2) "BL" suffix will be added to part number to designate DuraBlack™ finish.
- (3) See PEM Technical Support section of our website ([www.pemnet.com](http://www.pemnet.com)) for related plating standards and specifications.
- (4) Other shank and screw lengths available.



Get quote >>

Angic Global Solutions

1-888-872-0690 [www.angic.com](http://www.angic.com) 151

<https://www.AngicGlobal.com> Sales@AngicGlobal.com

# PEM® CAPTIVE PANEL SCREWS

## PEM® C.A.P.S.® CAPTIVE PANEL SCREWS

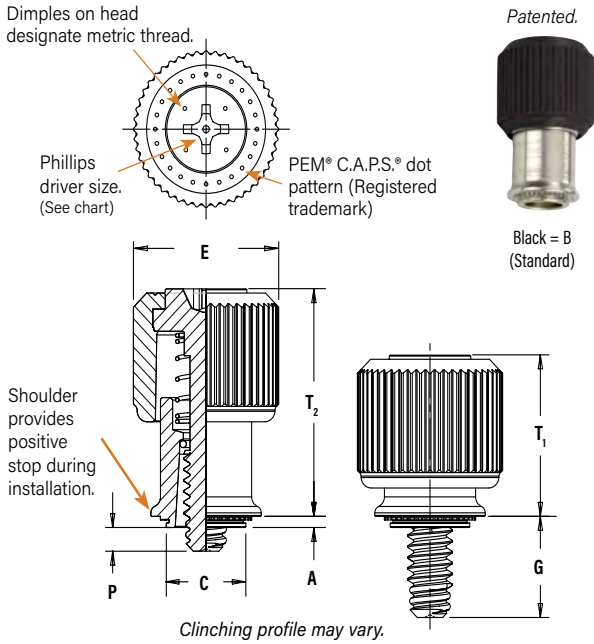

### Color Capabilities <sup>(1)</sup>

Choose a knob color code and add it to the end of the base part number.



<b>Threads:</b> External, ASME B1.1, 2A / ASME B1.13M, 6g <sup>(2)</sup>
<b>Material:</b> Knob: PC/ABS (UL 94V-0, halogen-free) <sup>(3)</sup> Retainer: Hardened Carbon Steel Screw: Hardened Carbon Steel Spring: 300 Series Stainless Steel Retaining Clip: 300 Series Stainless Steel
<b>Finish:</b> Retainer: CN - Bright nickel over copper flash per ASTM B689, Type II Screw: Zinc plated per ASTM B633, SC1 (5µm), Type III, colorless Spring: Natural Finish Retaining Clip: Natural Finish
<b>For use in sheet hardness:</b> HRB 80 or less (Hardness Rockwell "B" Scale) HB 150 or less (Hardness Brinell)

### PART NUMBER DESIGNATION

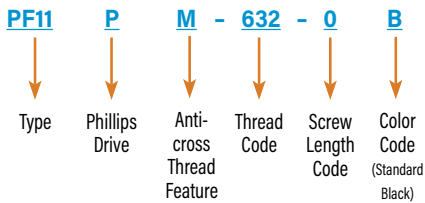

Also available with flare-mounted retainer as PF11PMF or with floating style retainer as PF11PMW.

Float .010"/0.25mm minimum, in all directions from center, .020"/0.5mm total.

Installation Data page 172. Performance Data page 181.

All dimensions are in inches.

UNIFIED	Thread Size	Type	Thread Code	Screw Length Code	A (Shank) Max.	Min. Sheet Thickness	Hole Size In Sheet +.003 - .000	C Max.	E ±.010	G ±.025	P ±.025	T <sub>1</sub> Nom.	T <sub>2</sub> Nom.	Driver Size	Min. Dist. Hole To Edge
		Knurled Cap													
.112-40 (#4-40)	PF11PM	440	0	.036	.036	.219	.218	.417	.170	.000	.310	.450	#2	.28	
			1						.230	.060					
			2						.290	.120					
.138-32 (#6-32)	PF11PM	632	0	.036	.036	.250	.249	.450	.230	.000	.450	.640	#2	.29	
			1						.290	.060					
			2						.350	.120					
.164-32 (#8-32)	PF11PM	832	0	.036	.036	.312	.311	.514	.230	.000	.450	.640	#2	.33	
			1						.290	.060					
			2						.350	.120					
.190-32 (#10-32)	PF11PM	032	0	.036	.036	.312	.311	.514	.230	.000	.450	.640	#2	.33	
			1						.290	.060					
			2						.350	.120					

All dimensions are in millimeters.

METRIC	Thread Size x Pitch	Type	Thread Code	Screw Length Code	A (Shank) Max.	Min. Sheet Thickness	Hole Size In Sheet + 0.08	C Max.	E ± 0.25	G ± 0.64	P ± 0.64	T <sub>1</sub> Nom.	T <sub>2</sub> Nom.	Driver Size	Min. Dist. Hole To Edge
		Knurled Cap													
M3 x 0.5	PF11PM	M3	0	0.92	0.92	5.56	5.54	10.59	4.32	0	7.87	11.43	#2	7.11	
			1						5.84	1.52					
			2						7.37	3.05					
M4 x 0.7	PF11PM	M4	0	0.92	0.92	7.92	7.9	13.06	5.84	0	11.43	16.26	#2	8.38	
			1						7.37	1.52					
			2						8.89	3.05					
M5 x 0.8	PF11PM	M5	0	0.92	0.92	7.92	7.9	13.06	5.84	0	11.43	16.26	#2	8.38	
			1						7.37	1.52					
			2						8.89	3.05					

- The colors shown (except for black) are non-stocked standards and available on special order. Since actual color knob may vary slightly from those represented, we recommend that you request samples for color verification. If you require a custom color or you need a "color matched" knob, please contact us.
- As with all Class 2A/6g external threads with an additive finish, the maximum major and pitch, after plating, may equal basic sizes and be gauged to Class 3A/4h, per ANSI B1.1, Section 8, Table 3A and ANSI B1.13M, Section 8, Paragraph 8.2.
- Temperature limit is 210° F / 99° C.

# PEM® CAPTIVE PANEL SCREWS

## PEM® PFHV™ CAPTIVE PANEL SCREWS

- Compact, low profile design for limited access applications
- Low cost captive screw design to replace loose hardware
- Two screw lengths
- Universal slot/Phillips recess standard with available Torx® recess
- Available with MATHread® anti cross-thread technology. (See page 150 for more information)

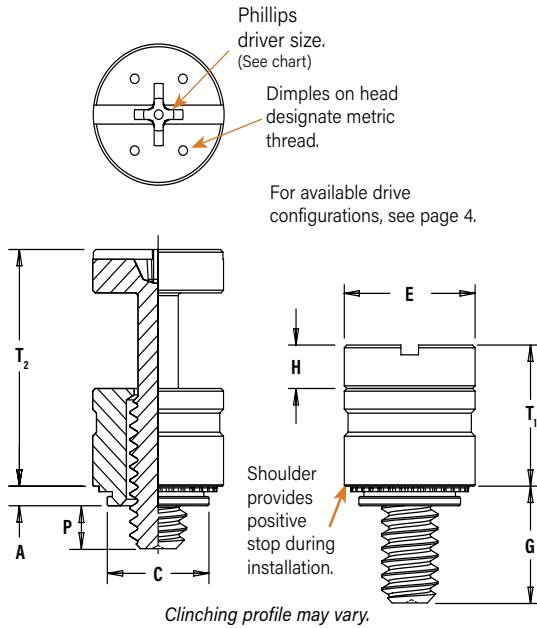

<b>Threads:</b>	External, ASME B1.1, 2A / ASME B1.13M, 6g <sup>(1)</sup>
<b>Material:</b>	Retainer: Carbon Steel Screw: Hardened Carbon Steel
<b>Finish:</b>	Retainer: CN - Bright nickel over copper flash per ASTM B689, Type II Screw: CN - Bright nickel over copper flash <sup>(1)</sup>
<b>For use in sheet hardness:</b>	HRB 60 or less (Hardness Rockwell "B" Scale) HB 107 or less (Hardness Brinell)

### PART NUMBER DESIGNATION

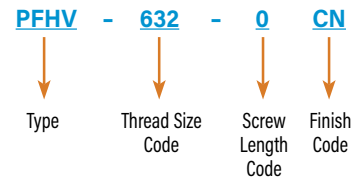

Installation Data page 173. Performance Data page 181.

All dimensions are in inches.

UNIFIED	Thread Size	Type	Thread Code	Screw Length Code	A (Shank) Max.	Min. Sheet Thickness	Hole Size In Sheet + .003 - .000	C Max.	E ± .010	G ± .025	H ± .005	P ± .025	T <sub>1</sub> Nom.	T <sub>2</sub> Nom.	Driver Size	Min. Dist. Hole To Edge
	.112-40 (#4-40)	PFHV	440	0	.036	.036	.203	.202	.260	.080	.216	.000	.260	.436	#1	.21
1				.316							.095					
.138-32 (#6-32)	PFHV	632	0	.036	.036	.219	.218	.276	.092	.234	.000	.290	.484	#2	.23	
			1							.359						.120
.164-32 (#8-32)	PFHV	832	0	.036	.036	.252	.251	.309	.111	.259	.000	.335	.555	#2	.26	
			1							.371						.106

All dimensions are in millimeters.

METRIC	Thread Size x Pitch	Type	Thread Code	Screw Length Code	A (Shank) Max.	Min. Sheet Thickness	Hole Size In Sheet + 0.08	C Max.	E ± 0.25	G ± 0.64	H ± 0.13	P ± 0.64	T <sub>1</sub> Nom.	T <sub>2</sub> Nom.	Driver Size	Min. Dist. Hole To Edge
	M3 x 0.5	PFHV	M3	0	0.92	0.92	5.5	5.49	6.95	2.03	5.55	0	6.69	11.25	#1	5.8
1				7.56							1.9					
M3.5 x 0.6	PFHV	M3.5	0	0.92	0.92	6	5.98	7.45	2.34	6.01	0	7.45	12.47	#2	6.3	
			1							8.42						2.3
M4 x 0.7	PFHV	M4	0	0.92	0.92	6.4	6.38	7.85	2.79	6.59	0	8.5	14.1	#2	6.7	
			1							9.39						2.7

(1) As with all Class 2A/6g external threads with an additive finish, the maximum major and pitch, after plating, may equal basic sizes and be gauged to Class 3A/4h, per ANSI B1.1, Section 8, Table 3A and ANSI B1.13M, Section 8, Paragraph 8.2.



Get quote >>

Angic Global Solutions

1-888-872-0690 [www.angic.com](http://www.angic.com) 153

<https://www.AngicGlobal.com> Sales@AngicGlobal.com

# PEM® CAPTIVE PANEL SCREWS

## PEM® PF7M™ AND PF7MF™ CAPTIVE PANEL SCREWS

- Smallest footprint, spring-loaded panel fastener for limited access applications
- MAThread® anti cross-thread technology (See page 4 for more information)
- Installs flush on back side of panel
- Available with Torx® recess
- PF7M Self-clinching style provides high pushout resistance
- PF7M does not require special hole preparation
- PF7MF is appropriate for close centerline-to-edge applications
- PF7MF does not require high installation force
- PF7MF installs into any panel hardness



## PF7M™ SELF-CLINCHING CAPTIVE PANEL SCREWS



Patented.

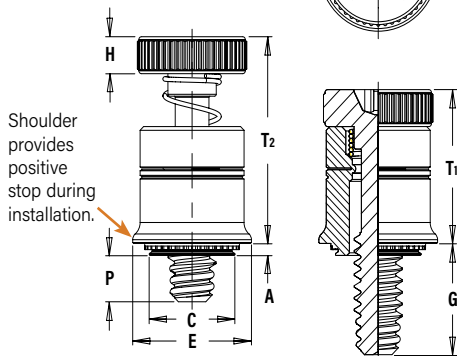

Clinching profile may vary.

Installation Data page 174. Performance Data page 182.

<b>Threads:</b> External, ASME B1.1, 2A / ASME B1.13M, 6g <sup>(1)</sup>
<b>Material:</b> Retainer: Carbon Steel Screw: Hardened Carbon Steel Spring: 300 Series Stainless Steel
<b>Finish:</b> Retainer: CN - Bright nickel over copper flash per ASTM B689, Type II Screw: CN - Bright nickel over copper flash Spring: Natural Finish
<b>For use in sheet hardness:</b> HRB 60 or less (Hardness Rockwell "B" Scale) HB 107 or less (Hardness Brinell)

### PART NUMBER DESIGNATION

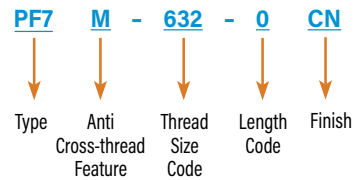

All dimensions are in inches.

UNIFIED	Thread Size	Type	Thread Code	Screw Length Code	A (Shank) Max.	Min. Sheet Thickness	Hole Size In Sheet +.003 - .000	C Max.	E ±.010	H ±.010	G ±.025	P ±.025	T1 Nom.	T2 Nom.	Driver Size	Min. Dist. Hole $\phi$ To Edge
		Fastener Material Steel														
	.112-40 (#4-40)	PF7M	440	0	.036	.036	.219	.218	.310	.100	.210	.000	.380	.550	#2	.28
				1												
	.138-32 (#6-32)	PF7M	632	0	.036	.036	.250	.249	.342	.100	.240	.000	.410	.610	#2	.29
				1												
	.164-32 (#8-32)	PF7M	832	0	.036	.036	.312	.311	.405	.120	.240	.000	.430	.630	#2	.33
				1												

All dimensions are in millimeters.

METRIC	Thread Size x Pitch	Type	Thread Code	Screw Length Code	A (Shank) Max.	Min. Sheet Thickness	Hole Size In Sheet +.08	C Max.	E ±.025	H ±.025	G ±.064	P ±.064	T1 Nom.	T2 Nom.	Driver Size	Min. Dist. Hole $\phi$ To Edge
		Fastener Material Steel														
	M3 x 0.5	PF7M	M3	0	0.92	0.92	5.56	5.54	7.87	2.5	5.33	0	9.65	13.97	#2	711
				1												
	M4 x 0.7	PF7M	M4	0	0.92	0.92	7.92	7.9	10.29	3	6.1	0	10.92	16	#2	8.38
				1												

(1) As with all Class 2A/6g external threads with an additive finish, the maximum major and pitch, after plating, may equal basic sizes and be gauged to Class 3A/4h, per ANSI B1.1, Section 8, Table 3A and ANSI B1.13M, Section 8, Paragraph 8.2.

# PEM® CAPTIVE PANEL SCREWS

## PF7MF™ FLARE-MOUNTED CAPTIVE PANEL SCREWS



Patented.

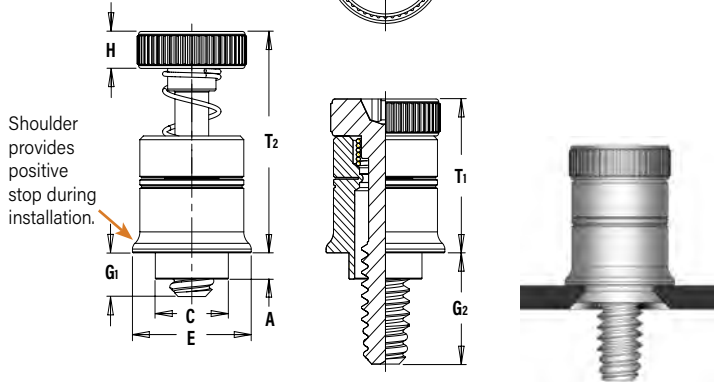
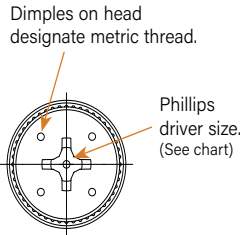

Installation Data page 174. Performance Data page 182.

**Threads:**  
External, ASME B1.1, 2A / ASME B1.13M, 6g <sup>(1)</sup>

**Material:**  
Retainer: Aluminum  
Screw: Hardened Carbon Steel  
Spring: 300 Series Stainless Steel  
Spring: Natural Finish

**Finish:**  
Retainer: Natural finish  
Screw: CN - Bright nickel over copper flash

### PART NUMBER DESIGNATION

**PF7 M F - 632 - 0**

Type    Anti Cross-thread Feature    Flaring    Thread Size Code    Length Code

All dimensions are in inches.

UNIFIED	Thread Size	Type	Thread Code	Screw Length Code	A (Shank) Max.	Min. Sheet Thickness	Hole Size In Sheet +.005 -.000	C Max.	E ±.010	H ±.010	G <sub>1</sub> ±.025	G <sub>2</sub> ±.025	T <sub>1</sub> Nom.	T <sub>2</sub> Nom.	Driver Size
		Fastener Material Steel													
	.112-40 (#4-40)	PF7MF	440	0	.041	.031	.187	.186	.310	.100	.040	.210	.380	.550	#2
				1											
	.138-32 (#6-32)	PF7MF	632	0	.072	.060	.213	.212	.342	.100	.040	.240	.410	.610	#2
				1											
	.164-32 (#8-32)	PF7MF	832	0	.072	.060	.266	.265	.405	.120	.040	.240	.430	.630	#2
				1											

All dimensions are in millimeters.

METRIC	Thread Size x Pitch	Type	Thread Code	Screw Length Code	A (Shank) Max.	Min. Sheet Thickness	Hole Size In Sheet +0.13	C Max.	E ±0.25	H ±0.25	G <sub>1</sub> ±0.64	G <sub>2</sub> ±0.64	T <sub>1</sub> Nom.	T <sub>2</sub> Nom.	Driver Size
		Fastener Material Steel													
	M3 x 0.5	PF7MF	M3	0	1.05	0.79	4.75	4.73	7.87	2.5	1.02	5.33	9.65	13.97	#2
				1											
	M4 x 0.7	PF7MF	M4	0	1.83	1.52	6.76	6.74	10.29	3	1.02	6.1	10.92	16	#2
				1											

(1) As with all Class 2A/6g external threads with an additive finish, the maximum major and pitch, after plating, may equal basic sizes and be gauged to Class 3A/4h, per ANSI B1.1, Section 8, Table 3A and ANSI B1.13M, Section 8, Paragraph 8.2.



Get quote >>

Angic Global Solutions

1-888-872-0690 [www.angic.com](http://www.angic.com) 155

<https://www.AngicGlobal.com> Sales@AngicGlobal.com

# PEM® CAPTIVE PANEL SCREWS

## PEM® PF30™, PF50™ AND PF60™ CAPTIVE PANEL SCREWS

- Low-profile design satisfies many functional and cosmetic requirements
- Convenient large head for tool or hand operation
- PF50/PF60 are available with Torx® recess
- PF50/PF60 are available with MATHread® anti cross-thread technology. (See page 4 for more information)



### PF30™ LOW-PROFILE CAPTIVE PANEL SCREWS

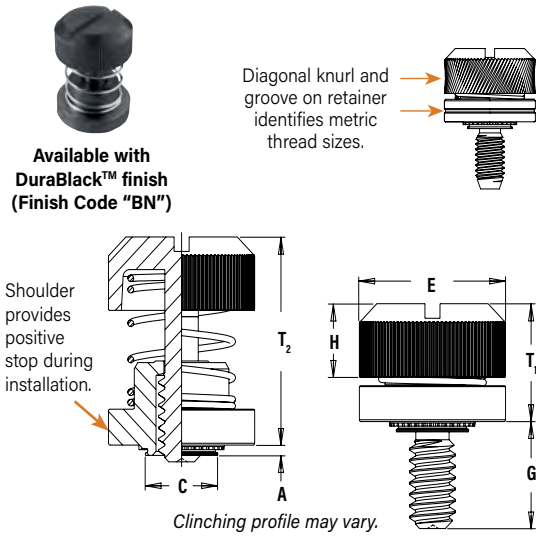

Available with DuraBlack™ finish (Finish Code "BN")

Diagonal knurl and groove on retainer identifies metric thread sizes.

Shoulder provides positive stop during installation.

Clinching profile may vary.

Installation Data page 175. Performance Data page 182.

<b>Threads:</b> External, ASME B1.1, 2A / ASME B1.13M, 6g <sup>(1)</sup>
<b>Material:</b> Retainer: Carbon Steel Screw: Hardened Carbon Steel (#4-40 and M3 sizes only) Carbon Steel (all other sizes) Spring: 300 Series Stainless Steel
<b>Finish:</b> Retainer: CN - Bright nickel over copper flash per ASTM B689, Type II Screw: CN - Bright nickel over copper flash per ASTM B689, Type II Spring: Natural Finish
<b>Optional Finish:</b> Retainer: BN - Black nitride, AMS2753, Section 3 Screw: BN - Black nitride, AMS2753, Section 3
<b>For use in sheet hardness:</b> HRB 60 or less (Hardness Rockwell "B" Scale) HB 107 or less (Hardness Brinell)

#### PART NUMBER DESIGNATION

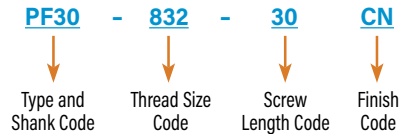

All dimensions are in inches.

UNIFIED	Thread Size	Type	Thread Code	Screw Length Code	A (Shank) Max.	Min. Sheet Thickness	Hole Size In Sheet +.003 -.000	C Max.	E ±.010	G ±.015	H ±.005	T <sub>1</sub> Max.	T <sub>2</sub> Nom.	Min. Dist. Hole To Edge
	.112-40 (#4-40)	PF30	440	30	.030	.030	.203	.202	.406	.300	.202	.325	.595	.26
PF31		.038			.040									
PF32		.058			.060									
.138-32 (#6-32)	PF30	632	30	.030	.030	.219	.218	.438	.300	.202	.325	.595	.28	
	PF31			.038	.040									
	PF32			.058	.060									
.164-32 (#8-32)	PF30	832	30	.030	.030	.250	.249	.468	.300	.207	.330	.600	.29	
	PF31			.038	.040									
	PF32			.058	.060									
.190-32 (#10-32)	PF30	032	30	.030	.030	.312	.311	.530	.300	.220	.335	.605	.33	
	PF31			.038	.040									
	PF32			.058	.060									
.250-20 (1/4-20)	PF32	0420	35	.058	.060	.375	.374	.625	.350	.242	.385	.675	.38	

All dimensions are in millimeters.

METRIC	Thread Size x Pitch	Type	Thread Code	Screw Length Code	A (Shank) Max.	Min. Sheet Thickness	Hole Size In Sheet + 0.08	C Max.	E ±0.25	G ± 0.4	H ± 0.13	T <sub>1</sub> Max.	T <sub>2</sub> Nom.	Min. Dist. Hole To Edge
	M3 x 0.5	PF31	M3	30	0.97	1	5.5	5.48	10.31	7.62	5.13	8.26	15.11	6.6
1.48					1.5									
M4 x 0.7	PF31	M4	30	0.97	1	6.4	6.38	11.89	7.62	5.26	8.38	15.24	7.37	
				1.48	1.5									
M5 x 0.8	PF31	M5	30	0.97	1	8	7.98	13.46	7.62	5.59	8.51	15.37	8.38	
				1.48	1.5									
M6 x 1	PF32	M6	35	1.48	1.5	9.5	9.48	15.88	8.89	6.12	9.78	17.15	9.65	

(1) As with all Class 2A/6g external threads with an additive finish, the maximum major and pitch, after plating, may equal basic sizes and be gauged to Class 3A/4h, per ANSI B1.1, Section 8, Table 3A and ANSI B1.13M, Section 8, Paragraph 8.2.

# PEM® CAPTIVE PANEL SCREWS

## PF50™/PF60™ LOW-PROFILE CAPTIVE PANEL SCREWS



Available with DuraBlack™ finish (Finish Code "BN")

Shoulder provides positive stop during installation.

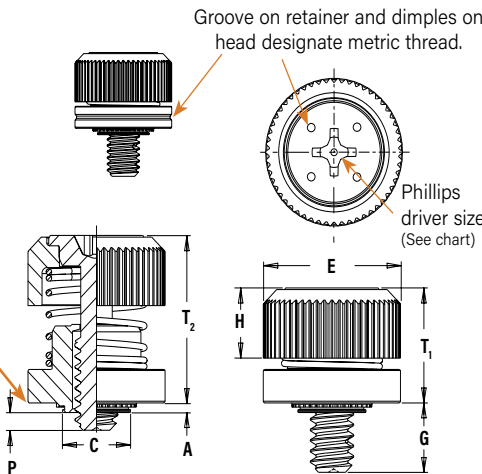

Installation Data page 175. Performance Data page 183.

<b>Threads:</b> External, ASME B1.1, 2A / ASME B1.13M, 6g <sup>(1)</sup>
<b>Material:</b> Knob: Carbon Steel                      Retainer: Carbon Steel Screw: Hardened Carbon Steel        Spring: 300 Series Stainless Steel
<b>Finish:</b> Knob: CN - Bright nickel over copper flash per ASTM B689, Type II Retainer: CN - Bright nickel over copper flash per ASTM B689, Type II Screw: CN - Bright nickel over copper flash Spring: Natural Finish
<b>Optional Finish:</b> Knob: BN - Black Nitride, AMS2753, Section 3 Retainer: BN - Black Nitride, AMS2753, Section 3 Screw: BN - Black Nitride, AMS2753, Section 3
<b>For use in sheet hardness:</b> HRB 60 or less (Hardness Rockwell "B" Scale) HB 107 or less (Hardness Brinell)

### PART NUMBER DESIGNATION

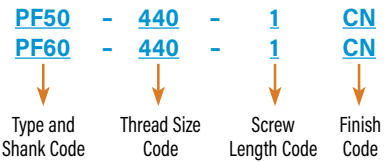

All dimensions are in inches.

Thread Size	Type		Thread Code	Screw Length Code	A (Shank) Max.	Min. Sheet Thickness	Hole Size In Sheet +.003 -.000	C Max.	E ±.010	G ±.025	H ±.008	P ±.025	T <sub>1</sub> Max.	T <sub>1</sub> Nom.	Driver Size	Min. Dist Hole To Edge
	Knurled Cap	Smooth Cap														
.112-40 (#4-40)	PF50	PF60	440	0	.030	.030	.203	.202	.406	.230	.207	.000	.340	.520	#1	.26
				1												
	PF51	PF61	440	0	.038	.040	.203	.202	.406	.230	.207	.000	.340	.520	#1	.26
				1												
	PF52	PF62	440	0	.058	.060	.203	.202	.406	.230	.207	.000	.340	.520	#1	.26
				1												
.138-32 (#6-32)	PF50	PF60	632	0	.030	.030	.219	.218	.438	.230	.207	.000	.340	.520	#2	.28
				1												
	PF51	PF61	632	0	.038	.040	.219	.218	.438	.230	.207	.000	.340	.520	#2	.28
				1												
	PF52	PF62	632	0	.058	.060	.219	.218	.438	.230	.207	.000	.340	.520	#2	.28
				1												
.164-32 (#8-32)	PF50	PF60	832	0	.030	.030	.250	.249	.468	.230	.217	.000	.340	.520	#2	.29
				1												
	PF51	PF61	832	0	.038	.040	.250	.249	.468	.230	.217	.000	.340	.520	#2	.29
				1												
	PF52	PF62	832	0	.058	.060	.250	.249	.468	.230	.217	.000	.340	.520	#2	.29
				1												
.190-32 (#10-32)	PF50	PF60	032	0	.030	.030	.312	.311	.530	.230	.225	.000	.340	.530	#2	.33
				1												
	PF51	PF61	032	0	.038	.040	.312	.311	.530	.230	.225	.000	.340	.530	#2	.33
				1												
	PF52	PF62	032	0	.058	.060	.312	.311	.530	.230	.225	.000	.340	.530	#2	.33
				1												
.250-20 (1/4-20)	PF52	PF62	0420	0	.058	.060	.375	.374	.625	.280	.246	.000	.395	.600	#2	.38
				1												

All dimensions are in millimeters.

Thread Size x Pitch	Type		Thread Code	Screw Length Code	A (Shank) Max.	Min. Sheet Thickness	Hole Size In Sheet + 0.08	C Max.	E ±.025	G ±.064	H ±.02	P ±.064	T <sub>1</sub> Max.	T <sub>1</sub> Nom.	Driver Size	Min. Dist Hole To Edge
	Knurled Cap	Smooth Cap														
M3 x 0.5	PF50	PF60	M3	0	0.77	0.8	5.5	5.48	10.3	5.84	5.26	0	8.64	13.21	#1	6.6
				1												
	PF51	PF61	M3	0	0.97	1	5.5	5.48	10.3	5.84	5.26	0	8.64	13.21	#1	6.6
				1												
	PF52	PF62	M3	0	1.48	1.5	5.5	5.48	10.3	5.84	5.26	0	8.64	13.21	#1	6.6
				1												
M3.5 x 0.6	PF50	PF60	M3.5	0	0.77	0.8	5.56	5.54	11.1	5.84	5.26	0	8.64	13.21	#2	7.1
				1												
	PF51	PF61	M3.5	0	0.97	1	5.56	5.54	11.1	5.84	5.26	0	8.64	13.21	#2	7.1
				1												
	PF52	PF62	M3.5	0	1.48	1.5	5.56	5.54	11.1	5.84	5.26	0	8.64	13.21	#2	7.1
				1												
M4 x 0.7	PF50	PF60	M4	0	0.77	0.8	6.4	6.38	11.9	5.84	5.51	0	8.64	13.46	#2	7.4
				1												
	PF51	PF61	M4	0	0.97	1	6.4	6.38	11.9	5.84	5.51	0	8.64	13.46	#2	7.4
				1												
	PF52	PF62	M4	0	1.48	1.5	6.4	6.38	11.9	5.84	5.51	0	8.64	13.46	#2	7.4
				1												
M5 x 0.8	PF50	PF60	M5	0	0.77	0.8	8	7.98	13.5	5.84	5.72	0	8.64	13.46	#2	8.4
				1												
	PF51	PF61	M5	0	0.97	1	8	7.98	13.5	5.84	5.72	0	8.64	13.46	#2	8.4
				1												
	PF52	PF62	M5	0	1.48	1.5	8	7.98	13.5	5.84	5.72	0	8.64	13.46	#2	8.4
				1												
M6 x 1	PF52	PF62	M6	0	1.48	1.5	9.5	9.48	15.9	7.11	6.25	0	10.04	15.24	#2	9.7
				1												

(1) As with all Class 2A/6g external threads with an additive finish, the maximum major and pitch, after plating, may equal basic sizes and be gauged to Class 3A/4h, per ANSI B1.1, Section 8, Table 3A and ANSI B1.13M, Section 8, Paragraph 8.2.



Get quote

Angic Global Solutions

1-888-872-0690 [www.angic.com](http://www.angic.com) 157

<https://www.AngicGlobal.com> Sales@AngicGlobal.com

# PEM® CAPTIVE PANEL SCREWS

## PFC4™ AND PFC2P™ CAPTIVE PANEL SCREWS

- Fully concealed-head for tool only access
- Comply with UL 60950 standards
- Available with MATHread® anti cross-thread technology (See page 4 for more information)
- Available with Torx® recess
- PFC4 installs into stainless steel sheets HRB 88 or less



### PFC4™ RECESSED-HEAD CAPTIVE PANEL SCREWS

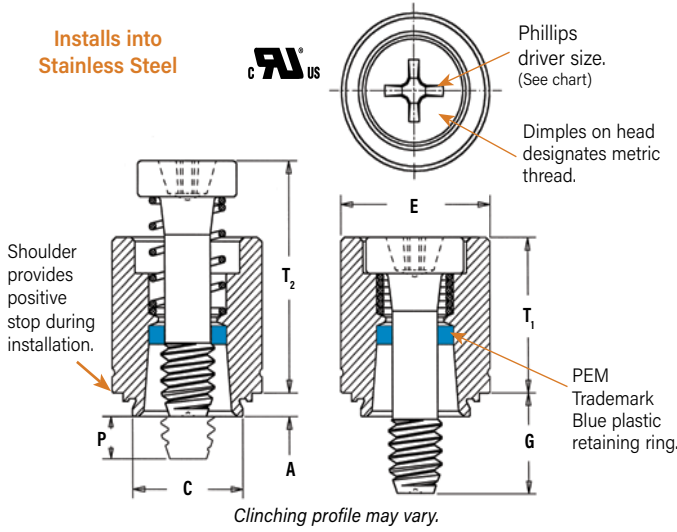

<b>Threads:</b> External, ASME B1.1, 2A / ASME B1.13M, 6g
<b>Material:</b> Retainer: 400 Series Stainless Steel Screw: 400 Series Stainless Steel Spring: 300 Series Stainless Steel Retaining Ring: Nylon, temperature limit 200° F / 93° C
<b>Finish:</b> Retainer: Passivated and/or tested per ASTM A380 Screw: Passivated and/or tested per ASTM A380 Spring: Natural Finish
<b>For use in sheet hardness:</b> HRB 88 or less (Hardness Rockwell "B" Scale) HB 183 or less (Hardness Brinell)

#### PART NUMBER DESIGNATION

**PFC4** - **832** - **50**



Installation Data page 176. Performance Data page 183.

All dimensions are in inches.

UNIFIED	Thread Size	Type	Thread Code	Screw Length Code	A (Shank) Max.	Min. Sheet Thickness	Hole Size In Sheet +.003 - .000	C Max.	E ± .010	G ± .016	P ± .025	T <sub>1</sub> Max.	T <sub>2</sub> Nom.	Driver Size	Min. Dist. Hole To Edge
	.112-40 (#4-40)	PFC4	440	40	.060	.060	.265	.264	.344	.250	.000	.370	.540	#1	.25
.138-32 (#6-32)	PFC4	632	62	.060	.060	.281	.280	.375	.250	.000	.380	.540	#2	.28	
			84	.060	.060	.281	.280	.375	.375	.125	.380	.540	#2	.28	
				.060	.060	.281	.280	.375	.500	.250	.380	.540	#2	.28	
.164-32 (#8-32)	PFC4	832	50	.060	.060	.312	.311	.406	.312	.000	.480	.705	#2	.31	
			72	.060	.060	.312	.311	.406	.437	.125	.480	.705	#2	.31	
			94	.060	.060	.312	.311	.406	.562	.250	.480	.705	#2	.31	
.190-32 (#10-32)	PFC4	032	50	.060	.060	.344	.343	.437	.312	.000	.490	.705	#2	.34	
			72	.060	.060	.344	.343	.437	.437	.125	.490	.705	#2	.34	
			94	.060	.060	.344	.343	.437	.562	.250	.490	.705	#2	.34	

All dimensions are in millimeters.

METRIC	Thread Size x Pitch	Type	Thread Code	Screw Length Code	A (Shank) Max.	Min. Sheet Thickness	Hole Size In Sheet + 0.08	C Max.	E ± 0.25	G ± 0.4	P ± 0.64	T <sub>1</sub> Max.	T <sub>2</sub> Nom.	Driver Size	Min. Dist. Hole To Edge
	M3 x 0.5	PFC4	M3	40	1.53	1.53	6.73	6.71	8.74	6.4	0	9.4	13.72	#1	6.35
62				1.53	1.53	6.73	6.71	8.74	9.5	3.2	9.4	13.72	#1	6.35	
M4 x 0.7	PFC4	M4	50	1.53	1.53	7.92	7.9	10.31	7.9	0	12.19	17.91	#2	7.87	
			72	1.53	1.53	7.92	7.9	10.31	11.1	3.2	12.19	17.91	#2	7.87	
			94	1.53	1.53	7.92	7.9	10.31	14.3	6.4	12.19	17.91	#2	7.87	
M5 x 0.8	PFC4	M5	50	1.53	1.53	8.74	8.72	11.1	7.9	0	12.45	17.91	#2	8.63	
			72	1.53	1.53	8.74	8.72	11.1	11.1	3.2	12.45	17.91	#2	8.63	
			94	1.53	1.53	8.74	8.72	11.1	14.3	6.4	12.45	17.91	#2	8.63	

#### A NOTE ABOUT FASTENERS FOR STAINLESS STEEL PANELS

In order for self-clinching fasteners to work properly, the fastener must be harder than the sheet into which it is being installed. In the case of stainless steel panels, fasteners made from 300 Series Stainless Steel do not meet this hardness criteria. It is for this reason that 400 series fasteners are offered (PFC4). However, while these 400 Series fasteners install and perform well in 300 Series stainless sheets they should not be used if the end product:

- Will be exposed to any appreciable corrosive presence.
- Requires non-magnetic fasteners.
- Will be exposed to any temperatures above 300° F (149° C)

If any of these are issues, please contact [techsupport@pemnet.com](mailto:techsupport@pemnet.com) for other options.

# PEM® CAPTIVE PANEL SCREWS

## PFC2P™ RECESSED-HEAD CAPTIVE PANEL SCREWS



Available with  
DuraBlack™ finish  
(Finish Code "BN")

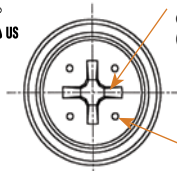

Phillips  
driver size.  
(See chart)

Dimples on head  
designates metric  
thread.

Shoulder  
provides  
positive  
stop during  
installation.

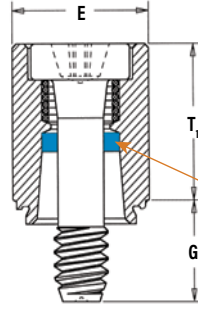
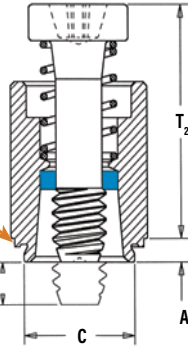

PEM  
Trademark  
Blue plastic  
retaining ring.

Clinching profile may vary.

Installation Data page 176. Performance Data page 183.

<b>Threads:</b> External, ASME B1.1, 2A / ASME B1.13M, 6g
<b>Material:</b> Retainer: 300 Series Stainless Steel Screw: 400 Series Stainless Steel Spring: 300 Series Stainless Steel Retaining Ring: Nylon, temperature limit 200° F / 93° C
<b>Finish:</b> Retainer: Passivated and/or tested per ASTM A380 Screw: Passivated and/or tested per ASTM A380 Spring: Natural Finish
<b>Optional Finish:</b> Retainer: BN - Black nitride, AMS2753, Section 3 Screw: BN - Black nitride, AMS2753, Section 3
<b>For use in sheet hardness:</b> HRB 70 or less (Hardness Rockwell "B" Scale) HB 125 or less (Hardness Brinell)

### PART NUMBER DESIGNATION

**PFC2P - 832 - 50**

Type and  
Material

Thread Size  
Code

Screw  
Length Code

All dimensions are in inches.

UNIFIED	Thread Size	Type	Thread Code	Screw Length Code	A (Shank) Max.	Min. Sheet Thickness	Hole Size In Sheet +.003 -.000	C Max.	E ± .010	G ± .016	P ± .025	T <sub>1</sub> Max.	T <sub>2</sub> Nom.	Driver Size	Min. Dist. Hole $\varnothing$ To Edge
	#4-40	PFC2P	440	40	40	.060	.060	.265	.264	.312	.250	.000	.370	.540	#1
62					.375						.125				
#6-32	PFC2P	632	40	.060	.060	.281	.280	.344	.344	.250	.000	.380	.540	#2	.28
			62							.375	.125				
			84							.500	.250				
#8-32	PFC2P	832	50	.060	.060	.312	.311	.375	.375	.312	.000	.480	.705	#2	.31
			72							.437	.125				
			94							.562	.250				
#10-32	PFC2P	032	50	.060	.060	.344	.343	.406	.406	.312	.000	.490	.705	#2	.34
			72							.437	.125				
			94							.562	.250				
1/4-20	PFC2P	0420	60	.060	.060	.413	.412	.468	.468	.375	.000	.620	.905	#3	.38
			82							.500	.125				
			04							.625	.250				

All dimensions are in millimeters.

METRIC	Thread Size x Pitch	Type	Thread Code	Screw Length Code	A (Shank) Max.	Min. Sheet Thickness	Hole Size In Sheet + 0.08	C Max.	E ± 0.25	G ± 0.4	P ± 0.64	T <sub>1</sub> Max.	T <sub>2</sub> Nom.	Driver Size	Min. Dist. Hole $\varnothing$ To Edge
	M3 x 0.5	PFC2P	M3	M3	40	1.53	1.53	6.73	6.71	7.92	6.4	0	9.4	13.72	#1
62					9.5						3.2				
M4 x 0.7	PFC2P	M4	M4	50	1.53	1.53	7.92	7.9	9.53	7.9	0	12.19	17.91	#2	7.87
				72						11.1	3.2				
				94						14.3	6.4				
M5 x 0.8	PFC2P	M5	M5	50	1.53	1.53	8.74	8.72	10.31	7.9	0	12.45	17.91	#2	8.63
				72						11.1	3.2				
				94						14.3	6.4				
M6 x 1	PFC2P	M6	M6	60	1.53	1.53	10.49	10.47	11.89	9.5	0	15.75	22.99	#3	9.65
				82						12.7	3.2				
				04						15.9	6.4				



Get quote >>

Angic Global Solutions

1-888-872-0690 [www.angic.com](http://www.angic.com) 159

<https://www.AngicGlobal.com> Sales@AngicGlobal.com

# PEM® CAPTIVE PANEL SCREWS

## PFC2™ AND PFS2™ CAPTIVE PANEL SCREWS

- Spring-loaded panel fastener for tool or hand operation
- Screw assemblies remain captive for easy mounting and removal.



PFC2		PFS2	
<b>Threads:</b> External, ASME B1.1, 2A / ASME B1.13M, 6g		<b>Threads:</b> External, ASME B1.1, 2A / ASME B1.13M, 6g <sup>(1)</sup>	
<b>Material:</b> Retainer: 300 Series Stainless Steel <sup>(2)</sup> Screw: 300 Series Stainless Steel Spring: 300 Series Stainless Steel Retaining Ring: Nylon, temperature limit 200° F / 93° C		<b>Material:</b> Retainer: Hardened Carbon Steel <sup>(2)</sup> Screw: Carbon Steel Spring: 300 Series Stainless Steel Retaining Ring: Nylon, temperature limit 200° F / 93° C	
<b>Finish:</b> Retainer: Passivated and/or tested per ASTM A380 Screw: Passivated and/or tested per ASTM A380 Spring: Natural Finish		<b>Finish:</b> Retainer: CN - Bright nickel over copper flash per ASTM B689, Type II Screw: CN - Bright nickel over copper flash per ASTM B689, Type II Spring: Natural Finish	
<b>Optional Finish:</b> Retainer: BN - Black nitride, AMS2753, Section 3 Screw: BN - Black nitride, AMS2753, Section 3		<b>Optional Finish:</b> Retainer: BN - Black nitride, AMS2753, Section 3 Screw: BN - Black nitride, AMS2753, Section 3	
<b>For use in sheet hardness:</b> HRB 70 or less (Hardness Rockwell "B" Scale) HB 125 or less (Hardness Brinell)		<b>For use in sheet hardness:</b> HRB 80 or less (Hardness Rockwell "B" Scale) HB 150 or less (Hardness Brinell)	

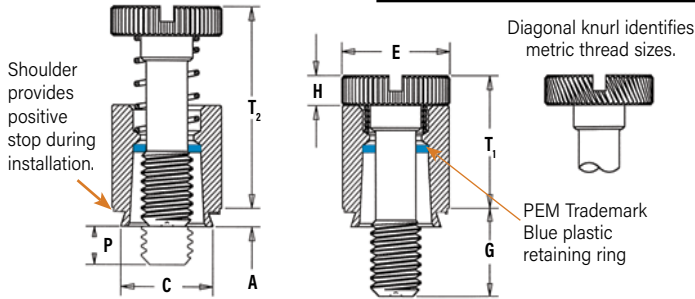

### PART NUMBER DESIGNATION

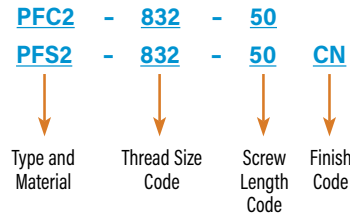

All dimensions are in inches.

Thread Size	Type		Thread Code	Screw Length Code	A (Shank) Max.	Min. Sheet Thickness	Hole Size In Sheet +.003 - .000	C Max.	E ± .010	G ±.016	H ±.005	P ±.025	T <sub>1</sub> Max.	T <sub>2</sub> Nom.	Min. Dist. Hole ⌀ To Edge
	Stainless Steel	Steel													
.112-40 (#4-40)	PFC2	PFS2	440	40	.060	.060	.265	.264	.312	.250	.072	.000	.360	.540	.25
				.375						.125					
.138-32 (#6-32)	PFC2	PFS2	632	40	.060	.060	.281	.280	.344	.250	.072	.000	.360	.540	.28
				.375						.125					
				.500						.250					
.164-32 (#8-32)	PFC2	PFS2	832	50	.060	.060	.312	.311	.375	.312	.082	.000	.450	.690	.31
				.437						.125					
				.562						.250					
.190-32 (#10-32)	PFC2	PFS2	032	50	.060	.060	.344	.343	.406	.312	.082	.000	.450	.690	.34
				.437						.125					
				.562						.250					
.250-20 (1/4-20)	PFC2	PFS2	0420	60	.060	.060	.413	.412	.468	.375	.097	.000	.580	.880	.38
				.500						.125					
				.625						.250					

Installation Data page 175. Performance Data page 181.

All dimensions are in millimeters.

Thread Size x Pitch	Type		Thread Code	Screw Length Code	A (Shank) Max.	Min. Sheet Thickness	Hole Size In Sheet + 0.08	C Max.	E ±.25	G ± 0.4	H ± 0.13	P ±0.64	T <sub>1</sub> Max.	T <sub>2</sub> Nom.	Min. Dist. Hole ⌀ To Edge
	Stainless Steel	Steel													
M3 x 0.5	PFC2	PFS2	M3	40	1.53	1.53	6.73	6.71	7.92	6.4	1.83	0	9.14	13.72	6.35
				9.5						3.2					
M4 x 0.7	PFC2	PFS2	M4	50	1.53	1.53	7.92	7.9	9.53	7.9	2.08	0	11.43	17.53	7.87
				11.1						3.2					
				14.3						6.4					
M5 x 0.8	PFC2	PFS2	M5	50	1.53	1.53	8.74	8.72	10.31	7.9	2.08	0	11.47	17.53	8.63
				11.1						3.2					
				14.3						6.4					
M6 x 1	PFC2	PFS2	M6	60	1.53	1.53	10.49	10.47	11.89	9.5	2.46	0	14.73	22.35	9.65
				12.7						3.2					
				15.9						6.4					

(1) As with all Class 2A/6g external threads with an additive finish, the maximum major and pitch, after plating, may equal basic sizes and be gauged to Class 3A/4h, per ANSI B1.1, Section 8, Table 3A and ANSI B1.13M, Section 8, Paragraph 8.2.  
 (2) The blue plastic retaining rings are a PEM trademark. The temperature limit is 200° F / 93° C.



Get quote >>

Angic Global Solutions

1-888-872-0690

<https://www.AngicGlobal.com> Sales@AngicGlobal.com

## PTL2™ AND PSL2™ SPRING-LOADED PLUNGER ASSEMBLIES

- Positioning pins for sliding components such as drawer slides and equipment consoles
- Fast installation and removal of components
- Reverse side of sheet is flush when plunger is retracted
- PTL2 has quick lockout feature to hold plunger in fully retracted position (Available as PSL2 without lockout feature on special order)
- For use in sheets of HRB 80 or less



PTL2/PSL2 installed and with mating panel. Minimum mating hole diameter .251" / 6.38 mm.

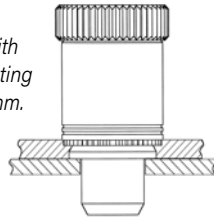

Lockout feature holds plunger in retracted position. Simply retract and twist to engage lockout feature.

Shoulder provides positive stop during installation.

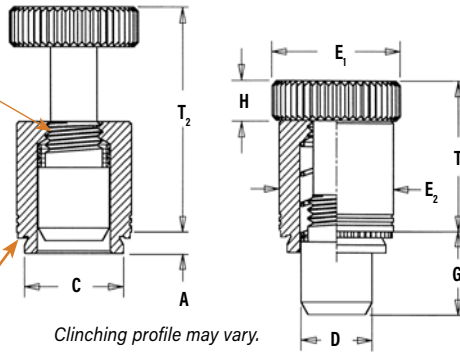

### Material:

Plunger: Hardened Carbon Steel  
Retainer: Hardened Carbon Steel  
Spring: 300 Series Stainless Steel

### Finish:

Plunger: CN - Bright nickel over copper flash per ASTM B689, Type II  
Retainer: CN - Bright nickel over copper flash per ASTM B689, Type II  
Spring: Natural Finish

### For use in sheet hardness:

HRB 80 or less (Hardness Rockwell "B" Scale)  
HB 150 or less (Hardness Brinell)

### PART NUMBER DESIGNATION

PTL2 - 04 - 4 CN

↓ Type      ↓ Plunger Diameter Code      ↓ Plunger Length Code      ↓ Finish Code

Installation Data page 175. Performance Data page 181.

All dimensions are in inches.

UNIFIED	Type	Plunger Diameter Code	Plunger Length Code	A (Shank) Max.	Min. Sheet Thickness	Hole Size In Sheet +.003 -.000	C Max.	D +.000 -.005	E <sub>1</sub> ±.010	E <sub>2</sub> ±.010	G ±.010	H ±.010	T <sub>1</sub> ±.010	T <sub>2</sub> Nom.	Min. Dist. Hole To Edge
	PTL2	04	4	.058	.060	.328	.327	.250	.50	.406	.310	.17	.595	.895	.34
PSL2 <sup>(1)</sup>	04	4	.058	.060	.328	.327	.250	.50	.406	.310	.17	.510	.780	.34	

All dimensions are in millimeters.

METRIC	Type	Plunger Diameter Code	Plunger Length Code	A (Shank) Max.	Min. Sheet Thickness	Hole Size In Sheet + 0.08	C Max.	D - 0.13	E <sub>1</sub> ± 0.25	E <sub>2</sub> ± 0.25	G ± 0.25	H ± 0.25	T <sub>1</sub> ± 0.25	T <sub>2</sub> Nom.	Min. Dist. Hole To Edge
	PTL2	04	4	1.47	1.53	8.33	8.31	6.35	12.7	10.3	7.87	4.32	15.11	22.73	8.64
PSL2 <sup>(1)</sup>	04	4	1.47	1.53	8.33	8.31	6.35	12.7	10.3	7.87	4.32	12.95	19.81	8.64	

(1) Without lockout feature. Available on special order.



Get quote »

Angic Global Solutions

1-888-872-0690 [www.angic.com](http://www.angic.com) 161

<https://www.AngicGlobal.com> Sales@AngicGlobal.com

# PEM® CAPTIVE PANEL SCREWS

## PEM® SCBR™/SCB™/SCBJ™ CAPTIVE PANEL SCREWS

- Permanently captivates into sheets as thin as .040" / 1.02 mm
- Lowest cost captive screw design to replace loose hardware
- Available with self-retracting (SCBR), axial float (SCB), or jacking feature (SCBJ)
- Appropriate for close centerline-to-edge applications



## SCBR™ SPINNING CLINCH BOLT WITH SELF-RETRACTING FEATURE

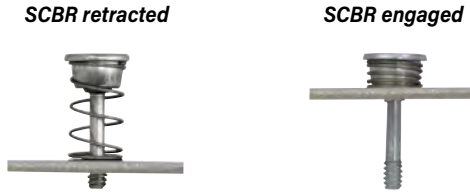
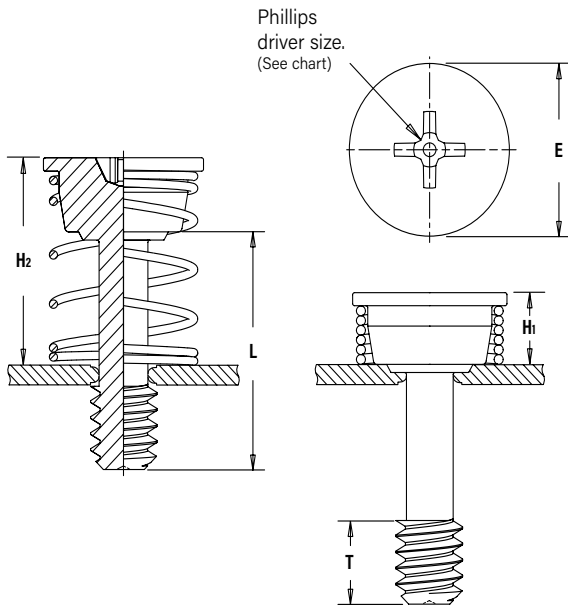

<b>Threads:</b> External, ASME B1.1, 2A / ASME B1.13M, 6g <sup>(1)</sup>
<b>Material:</b> Screw - Hardened Carbon Steel Spring - 300 series stainless steel
<b>Finish:</b> Screw - Zinc plated per ASTM B633, SC1 (5µm), Type III, colorless Spring: Natural Finish
<b>For use in sheet hardness:</b> HRB 80 or less (Hardness Rockwell "B" Scale) HB 150 or less (Hardness Brinell)

### PART NUMBER DESIGNATION

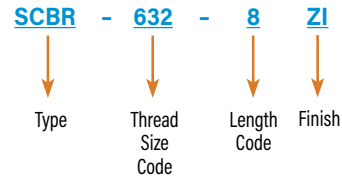

Installation Data page 176. Performance Data page 182.

All dimensions are in inches.

UNIFIED	Thread Size	Type	Thread Code	Length Code "L" ±.015 (Length Code in 16ths of an inch)	Min. Sheet Thickness	Hole Size in Sheet +.003 -.000	E +.005 -.010	H <sub>1</sub> ±.005	H <sub>2</sub> Ref.	T Nom.	Driver Size	Min. Dist Hole To Edge
				.500								
	.112-40 (#4-40)	SCBR	440	8	.040	.112	.348	.165	.495	.130	#1	.175
	.138-32 (#6-32)	SCBR	632	8	.040	.138	.381	.170	.500	.130	#2	.190
	.164-32 (#8-32)	SCBR	832	8	.040	.164	.410	.175	.505	.130	#2	.205

All dimensions are in millimeters.

METRIC	Thread Size x Pitch	Type	Thread Code	Length Code "L" ±0.4 (Length Code in millimeters)	Min. Sheet Thickness	Hole Size in Sheet +0.08	E +0.13 -0.25	H <sub>1</sub> ±0.13	H <sub>2</sub> Ref.	T Nom.	Driver Size	Min. Dist Hole To Edge
	M3 x 0.5	SCBR	M3	12	1.02	3	9.1	4.2	11.8	3.3	#1	4.5
	M4 x 0.7	SCBR	M4	12	1.02	4	10.7	4.5	12.1	3.3	#2	5.4

(1) As with all Class 2A/6g external threads with an additive finish, the maximum major and pitch, after plating, may equal basic sizes and be gauged to Class 3A/4h, per ANSI B1.1, Section 8, Table 3A and ANSI B1.13M, Section 8, Paragraph 8.2.

**NOTE:** SCBR screws are shipped with mating springs.

For designs requiring a specific spring rate, contact our PEM Technical Support group at [techsupport@pemnet.com](mailto:techsupport@pemnet.com).



# PEM® CAPTIVE PANEL SCREWS

## SCB™/SCBJ™ SPINNING CLINCH BOLTS

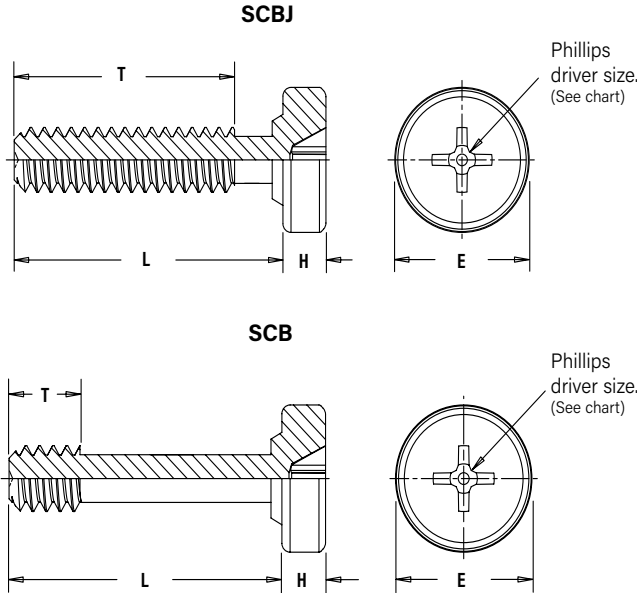

<b>Threads:</b>	External, ASME B1.1, 2A / ASME B1.13M, 6g <sup>(1)</sup>
<b>Material:</b>	Hardened Carbon Steel
<b>Finish:</b>	Zinc plated per ASTM B633, SC1 (5µm), Type III, colorless
<b>For use in sheet hardness:</b>	HRB 80 or less (Hardness Rockwell "B" Scale) HB 150 or less (Hardness Brinell)

### PART NUMBER DESIGNATION

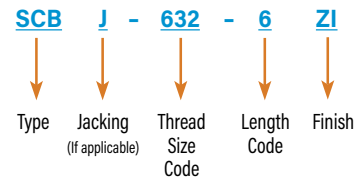

Installation Data page 176. Performance Data page 182.

All dimensions are in inches.

UNIFIED	Thread Size	Type		Thread Code	Length Code "L" ±.015 (Length Code in 16ths of an inch)			Min. Sheet Thickness	Hole Size in Sheet +.003 -.000	E ±.010	H Nom.	T Nom.			Nom. Axial Float	Driver Size	Min. Dist. Hole $\varnothing$ To Edge
		Jacking	Non-jacking		.250	.375	.500					-4	-6	-8			
	.112-.40 (#4-40)	SCBJ	—	440	4	6	8	.040	.112	.250	.080	.160	.285	.410	—	#1	.13
		—	SCB		—	—	—					8	—	—			
	.138-.32 (#6-32)	SCBJ	—	632	4	6	8	.040	.138	.291	.080	.160	.285	.410	—	#2	.15
		—	SCB		—	—	—					8	—	—			

All dimensions are in millimeters.

METRIC	Thread Size x Pitch	Type		Thread Code	Length Code "L" ±0.4 (Length Code in millimeters)				Min. Sheet Thickness	Hole Size in Sheet +0.08	E ±0.25	H Nom.	T Nom.				Nom. Axial Float	Driver Size	Min. Dist. Hole $\varnothing$ To Edge
		Jacking	Non-jacking		6	10	12	14					-6	-10	-12	-14			
	M3 x 0.5	SCBJ	—	M3	6	10	12	14	1.02	3	6.6	2.03	3.7	7.7	9.7	11.7	—	#1	3.3
		—	SCB		—	—	—	12					14	—	—	3.3			
	M4 x 0.7	SCBJ	—	M4	6	10	12	14	1.02	4	8.28	2.03	3.7	7.7	9.7	11.7	—	#2	5
		—	SCB		—	—	—	12					14	—	—	3.3			

(1) As with all Class 2A/6g external threads with an additive finish, the maximum major and pitch, after plating, may equal basic sizes and be gauged to Class 3A/4h, per ANSI B1.1, Section 8, Table 3A and ANSI B1.13M, Section 8, Paragraph 8.2.



Get quote »

Angic Global Solutions

1-888-872-0690 [www.angic.com](http://www.angic.com) 163

<https://www.AngicGlobal.com> Sales@AngicGlobal.com

# PEM® CAPTIVE PANEL SCREWS

## PEM® HSCB™ HEAT SINK MOUNTING SYSTEM

The HSCB™ engineered mounting system provides secure attachment of a heat sink to the circuit board while providing firm contact to the chip component allowing optimum heat dissipation. The three-piece fastening system, sold individually, includes the screw, spring and receptacle nut. The clamp load created is determined by the spring rate and the amount of deflection that is designed into the joint of the hardware. The system also allows for slight expansion and contraction of the joint components without stress to the delicate circuitry. The unique "click" feature lets the user know when the fastener is completely installed.

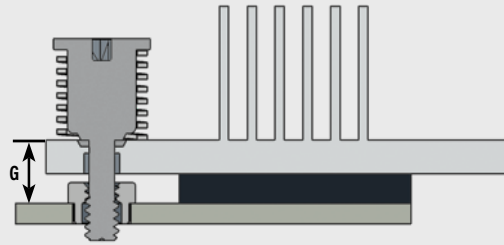

### To select proper length code of nut/standoff:

- 1) Determine "G", the distance from the top surface of the heat sink to the top of the P.C. Board.
- 2) Find the combination of Screw (HSCB) and Nut (HSR) whose sum of Screw Factor (SF) plus Nut Factor (NF) are closest to G.
- 3) Find  $D = G - SF - NF$ . The D value must be a negative number between zero and 1mm or 1/32" (1 dash length of HSR nut).
- 4) The actual working load is equal to the Spring (HSL) Working Load + (D x spring rate k). Lower D value results in lower force.

- Screw can not be overtightened. Audible "click" when fully engaged.
- Screw and spring mount together permanently into the heat sink.
- Spring determines clamp force.
- Receptacle nut mounts permanently to the P.C. board.
- Provides even, constant contact of heat sink to chip component.
- Allows removal of heat sink if desired.

*If this or any standard product does not meet your application needs, contact our PEM Technical Support group at [techsupport@pemnet.com](mailto:techsupport@pemnet.com) to develop a special product that matches your specific application.*

## HSCB™ SELF-CAPTIVATING SCREW

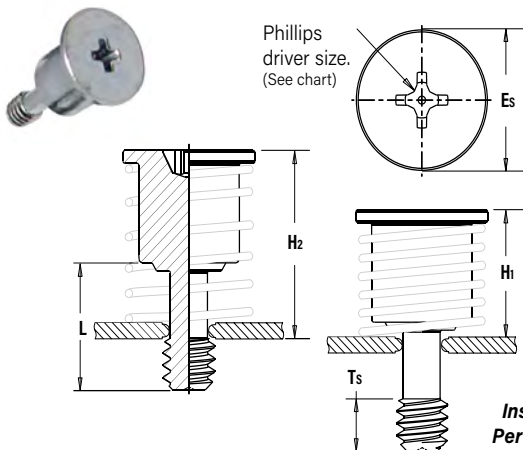

Installation Data page 177.  
Performance Data page 182.

<b>Threads:</b> External, ASME B1.1, 2A / ASME B1.13M, 6g <sup>(1)</sup>
<b>Material:</b> Hardened carbon steel
<b>Finish:</b> Screw - Zinc plated per ASTM B633, SC1 (5µm), Type III, colorless
<b>For use in sheet hardness:</b> HRB 80 / HB150 or less <sup>(2)</sup>

### PART NUMBER DESIGNATION

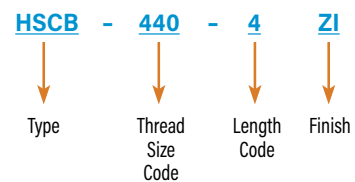

All dimensions are in inches.

UNIFIED	Thread Size	Type	Thread Code	Length Code "L" ±.015	Min. Sheet Thickness	Hole Size in Sheet +.003 -.000	Es ±.010	H1 Ref.	H2 Ref.	Ts Min.	Screw Factor (SF)	Driver Size	Min. Dist Hole ⌀ To Edge
				.320									
	.112-40 (#4-40)	HSCB	440	4	.040	.112	.312	.300	.470	.130	.170	#1	.156
	.138-32 (#6-32)	HSCB	632	4	.040	.138	.352	.300	.470	.130	.170	#2	.178

All dimensions are in millimeters.

METRIC	Thread Size x Pitch	Type	Thread Code	Length Code "L" ±0.4	Min. Sheet Thickness	Hole Size in Sheet +0.08	Es ±0.25	H1 Ref.	H2 Ref.	Ts Min.	Screw Factor (SF)	Driver Size	Min. Dist Hole ⌀ To Edge
				8.13									
	M3 x 0.5	HSCB	M3	3	1	3	8.18	7.67	12	3.3	4.32	#1	4.13

**NOTE:** HSCB screws, HSR nuts and HSL springs are sold separately.

- (1) As with all Class 2A/6g external threads with an additive finish, the maximum major and pitch, after plating, may equal basic sizes and be gauged to Class 3A/4h, per ANSI B1.1, Section 8, Table 3A and ANSI B1.13M, Section 8, Paragraph 8.2.
- (2) HRB - Hardness Rockwell "B" Scale. HB - Hardness Brinell.

# PEM® CAPTIVE PANEL SCREWS

## HSR™ BROACHING NUT/STANDOFF

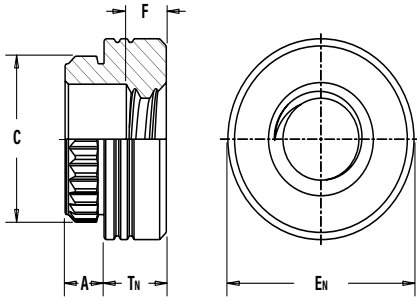

HSR nuts are available for surface mounting. Contact our [PEM technical support group at techsupport@pemnet.com](mailto:techsupport@pemnet.com).

<b>Threads:</b> Internal, ASME B1.1, 2B / ASME B1.13M, 6H
<b>Material:</b> Carbon steel
<b>Finish:</b> ET - Electro-plated tin ASTM B 545, class B with clear preservative coating, annealed <sup>(1)</sup>
<b>For use in sheet hardness:</b> HRB 60 / HB 107 or less <sup>(2)</sup>

### PART NUMBER DESIGNATION

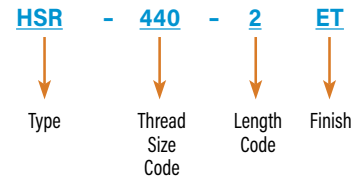

Installation Data page 177. Performance Data page 182.

All dimensions are in inches.

UNIFIED	Thread Size	Type	Thread Code	Length Code	A (Shank) Max.	Min. Sheet Thickness	Hole Size In Sheet +.003 -.000	C ±.003	En ±.005	F ±.010	Tw ±.005	Nut Factor (NF)	Min. Dist. Hole To Edge
	.112-40 (#4-40)	HSR	440	2	.060	.060	.166	.184	.219	.060	.065	.000	.017
3	.093			.031									
.138-32 (#6-32)		HSR	632		2	.060	.060	.213	.231	.281	.060	.065	.000
3	.093			.031									

All dimensions are in millimeters.

METRIC	Thread Size x Pitch	Type	Thread Code	Length Code	A (Shank) Max.	Min. Sheet Thickness	Hole Size In Sheet +0.08	C ±0.08	En ±0.13	F ±0.25	Tw ±0.13	Nut Factor (NF)	Min. Dist. Hole To Edge
	M3 x 0.5	HSR	M3	2	1.53	1.53	4.22	4.68	5.56	1.3	2	.75	4.4
3	1.75												

**NOTE:** HSCB screws, HSR nuts and HSL springs are sold separately.

- (1) See PEM Technical Support section of our website ([www.pemnet.com](http://www.pemnet.com)) for related plating standards and specifications.  
 (2) HRB - Hardness Rockwell "B" Scale. HB - Hardness Brinell.

## HSL™ SPRINGS

HSL springs are engineered to provide a reliable and repeatable spring rate when assembled with mating PEM hardware. The spring rate is critical to the successful assembly of your heat sink. Clamp load will be determined by the spring rate and deflection that is designed into the joint.

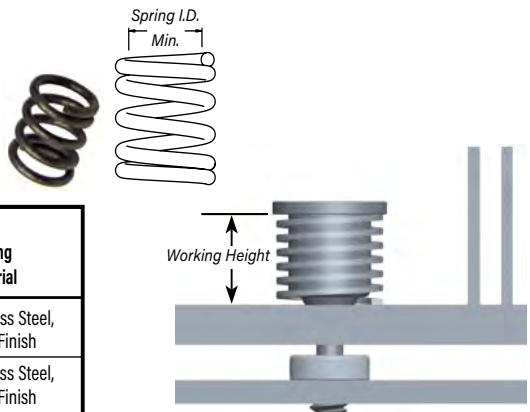

Part Number	Minimum Inside Dia.		Load at Working Height ±10%		Working Height Ref.		Spring Rate k		Spring Material
	(in.)	(mm)	(lbs.)	(N)	(in.)	(mm)	(lb/in)	(N/mm)	
HSL-574-35	.226	5.74	7.87	35	.270	6.86	74	12.96	17-7 Stainless Steel, Natural Finish
HSL-701-35	.276	7.01	7.87	35	.270	6.86	39	6.84	17-7 Stainless Steel, Natural Finish

**NOTE:** HSCB screws, HSR nuts and HSL springs are sold separately. HSL-574-35 spring fits screw thread sizes #4-40 and M3 and HSL-701-35 spring fits screw thread size #6-32.

The HSL **Inside Diameter Code** is expressed in hundredths of millimeters. Example "574" indicates a minimum inside diameter of 5.74mm or .226".

The HSL **Load Code** is expressed in Newtons developed at the working height of the spring once the joint is assembled. Example "35" indicates working load of 35 Newtons, or approximately 8 lbs.

For designs requiring a specific spring rate, contact our PEM Technical Support group at [techsupport@pemnet.com](mailto:techsupport@pemnet.com)

### PART NUMBER DESIGNATION

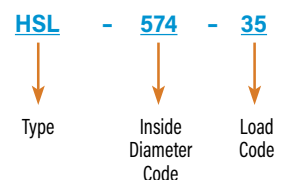

Get quote >>

Angic Global Solutions

1-888-872-0690 [www.angic.com](http://www.angic.com) 165

<https://www.AngicGlobal.com> Sales@AngicGlobal.com



# PEM® CAPTIVE PANEL SCREWS

## PR10™ SELF-CLINCHING FLUSH-MOUNTED RETAINERS

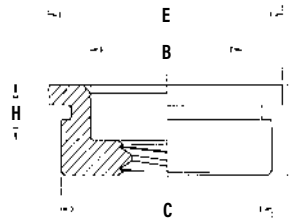

### PART NUMBER DESIGNATION

**PR10** - **832**

Type                      Thread Size Code

Clinching profile may vary.

**Threads:**  
Internal, ASME B1.1, 2B / ASME B1.13M, 6H <sup>(1)</sup>

**Material:**  
300 Series Stainless Steel

**Finish:**  
Passivated and/or tested per ASTM A380

**For use in sheet hardness:**  
HRB 70 or less (Hardness Rockwell "B" Scale)  
HB 125 or less (Hardness Brinell)

All dimensions are in inches.

UNIFIED	Thread Size	Type	Thread Code	A (Shank) Max.	Min. Sheet for Self-Clinching	Min. Sheet for Flush Installation	Hole Size in Sheet +.003 - .000	B Nom.	C Max.	E Nom.	H Nom.	Min. Dist. Hole to Edge
	.112-40 (#4-40)	PR10	440	.125	.050	.125	.281	.195	.280	.31	.075	.31
	.138-32 (#6-32)	PR10	632	.125	.050	.125	.312	.225	.311	.34	.075	.33
	.164-32 (#8-32)	PR10	832	.125	.050	.125	.344	.255	.343	.37	.075	.34
	.190-32 (#10-32)	PR10	032	.125	.050	.125	.375	.290	.374	.41	.075	.36

All dimensions are in millimeters.

METRIC	Thread Size x Pitch	Type	Thread Code	A (Shank) Max.	Min. Sheet for Self-Clinching	Min. Sheet for Flush Installation	Hole Size in Sheet + 0.08	B Nom.	C Max.	E Nom.	H Nom.	Min. Dist. Hole to Edge
	M3 x 0.5	PR10	M3	3.18	1.27	3.18	7.14	4.75	7.12	7.87	1.91	7.87
	M4 x 0.7	PR10	M4	3.18	1.27	3.18	8.74	6.48	8.72	9.53	1.91	8.64
	M5 x 0.8	PR10	M5	3.18	1.27	3.18	9.53	7.37	9.5	10.41	1.91	9.14

## N10™ SELF-CLINCHING RECEPTACLE NUTS<sup>(3)</sup>

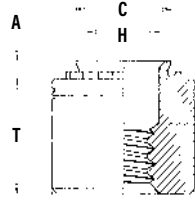

### PART NUMBER DESIGNATION

**N10** - **832** - **1** **ZI**

Type                      Thread Size Code                      Shank Code                      Finish

Clinching profile may vary.

**Threads:**  
Internal, ASME B1.1, 2B / ASME B1.13M, 6H <sup>(2)</sup>

**Material:**  
Hardened Carbon Steel

**Finish:**  
Zinc plated per ASTM B633, SC1 (5µm), Type III, colorless

**For use in sheet hardness:**  
HRB 80 or less (Hardness Rockwell "B" Scale)  
HB 150 or less (Hardness Brinell)

All dimensions are in inches.

UNIFIED	Thread Size	Type	Thread Code	Shank Code	A (Shank) Max.	Min. Sheet Thickness	Hole Size in Sheet +.003 - .000	C Max.	E Nom.	F ± .010	H Nom.	T ± .005	Min. Dist. Hole To Edge
	.112-40 (#4-40)	N10	440	1	.038	.040	.187	.186	.28	.130	.126	.24	.22
	.138-32 (#6-32)	N10	632	1	.038	.040	.213	.212	.31	.130	.156	.24	.27
	.164-32 (#8-32)	N10	832	1	.038	.040	.250	.249	.34	.130	.187	.24	.28
	.190-32 (#10-32)	N10	032	1	.038	.040	.277	.276	.37	.130	.213	.24	.31

All dimensions are in millimeters.

METRIC	Thread Size x Pitch	Type	Thread Code	Shank Code	A (Shank) Max.	Min. Sheet Thickness	Hole Size in Sheet + 0.08	C Max.	E Nom.	F ± 0.25	H Nom.	T ± 0.13	Min. Dist. Hole To Edge
	M3 x 0.5	N10	M3	1	0.97	1	4.75	4.73	7.11	3.3	3.2	6	5.59
	M4 x 0.7	N10	M4	1	0.97	1	6.35	6.33	8.64	3.3	4.75	6	7.11
	M5 x 0.8	N10	M5	1	0.97	1	7.04	7.01	9.53	3.3	5.41	6	7.87

- (1) The purpose of the thread is for component screw retention only, thread may not accept 2B/6H Go threaded plug gage, but class 3A/4h screw must pass with finger torque, may not reject NoGo threaded plug gage and minor diameter may exceed 2B/6H maximum.
- (2) 2B (unified) and 6H (metric) go gauge may stop at pilot end but class 3A (unified) and 4h (metric) screws will pass through with finger torque.
- (3) Also available on special order F10 self-clinching floating receptacle nuts.



Get quote >>

Angic Global Solutions

1-888-872-0690 [www.angic.com](http://www.angic.com) 167

<https://www.AngicGlobal.com> Sales@AngicGlobal.com

# PEM® CAPTIVE PANEL SCREWS

## REELFAST® SMTPLFSM™ SURFACE MOUNT CAPTIVE PANEL SCREWS

- All metal captive screw assembly installs in one piece utilizing pick and place method
- Combination drive, Torx®/slot
- Solderable finish

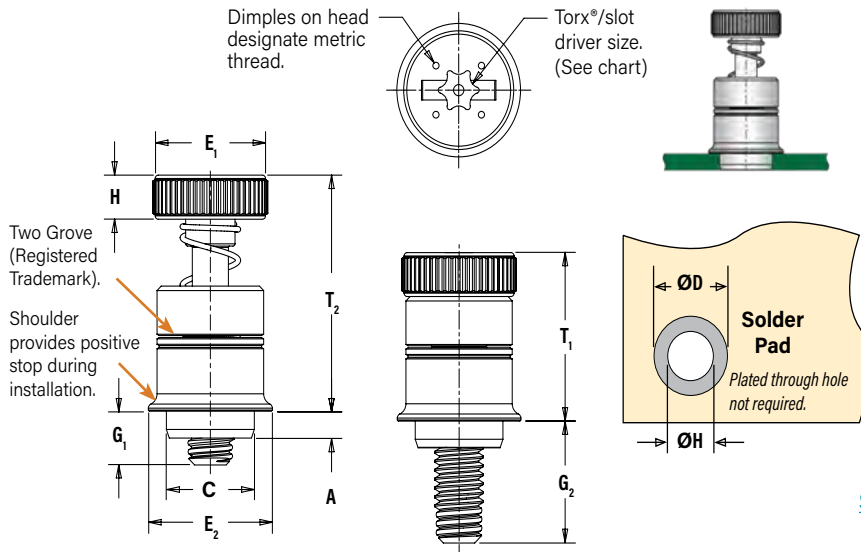

<b>Threads:</b>	External, ASME B1.1, 2A / ASME B1.13M, 6g <sup>(1)</sup>
<b>Material:</b>	Retainer: Carbon Steel Screw: Hardened Carbon Steel Spring: 300 Series Stainless Steel
<b>Finish:</b>	Retainer: ET - Electro-plated tin ASTM B545, Class A with preservative coating, annealed <sup>(2)</sup> Screw: Zinc plated per ASTM B633, SC1 (5µm), Type III, colorless Spring: Natural Finish

### PART NUMBER DESIGNATION

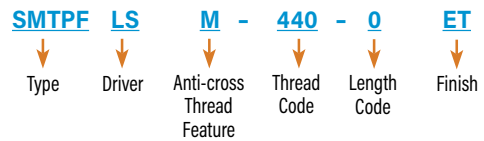

Installation Data page 178. Performance Data page 183.

All dimensions are in inches.

UNIFIED	Thread Size	Type	Thread Code	Screw Length Code	A (Shank) Max.	Min. Sheet Thickness	C Max.	E <sub>1</sub> ±.010	E <sub>2</sub> Nom.	G <sub>1</sub> ±.025	G <sub>2</sub> ±.025	H ±.010	T <sub>1</sub> Nom.	T <sub>2</sub> Nom.	ØK Hole Size in Sheet +.003-.000	ØD Min. Solder Pad	Driver Size
	.112-40 (#4-40)	SMTPLFSM	440	0 1	.063	.063	.215	.280	.300	.040 .100	.210 .270	.100	.38	.55	.220	.340	T15
.138-32 (#6-32)	SMTPLFSM	632	0 1	.063	.063	.247	.310	.320	.040 .100	.240 .300	.100	.42	.62	.252	.400	T15	

All dimensions are in millimeters.

METRIC	Thread Size	Type	Thread Code	Screw Length Code	A (Shank) Max.	Min. Sheet Thickness	C Max.	E <sub>1</sub> ±0.25	E <sub>2</sub> Nom.	G <sub>1</sub> ±0.64	G <sub>2</sub> ±0.64	H ±0.25	T <sub>1</sub> Nom.	T <sub>2</sub> Nom.	ØK Hole Size in Sheet +0.08	ØD Min. Solder Pad	Driver Size
	M3 x 0.5	SMTPLFSM	M3	0 1	1.6	1.6	5.46	7	7.6	1 2.5	5.3 6.8	2.5	9.6	14	5.6	8.6	T15
M3.5 x 0.6	SMTPLFSM	M3.5	0 1	1.6	1.6	6.27	7.9	8.13	1 2.5	6.1 7.62	2.5	10.7	15.7	6.4	10.2	T15	

### NUMBER OF PARTS PER REEL

Thread Size	Parts Per Reel
440	200
632	150
M3	200
M3.5	150



Packaged on 330 mm recyclable reels. Tape width is 24 mm. Supplied with polyimide patch for vacuum pick up. Reels conform to EIA-481.

(1) As with all Class 2A/6g external threads with an additive finish, the maximum major and pitch, after plating, may equal basic sizes and be gauged to Class 3A/4h, per ANSI B1.1, Section 8, Table 3A and ANSI B1.13M, Section 8, Paragraph 8.2  
(2) Optimal solderability life noted on packaging.

# PEM® CAPTIVE PANEL SCREWS

## REELFAST® SMTPF™ SURFACE MOUNT CAPTIVE PANEL SCREWS

- Retainer installed using conventional surface mount techniques
- Simply snap screw into retainer to complete assembly
- Black ABS knob standard
- Optional molded-through colors available
- Available with Torx® recess

<b>Threads:</b> External, ASME B1.1, 2A / ASME B1.13M, 6g <sup>(1)</sup>
<b>Material:</b> Knob: ABS <sup>(2)</sup> Retainer: Carbon Steel Screw: Carbon Steel
<b>Finish:</b> Retainer: ET - Electro-plated tin ASTM B545, Class A with preservative coating, annealed Screw: CN - Bright nickel over copper flash per ASTM B689, Type II

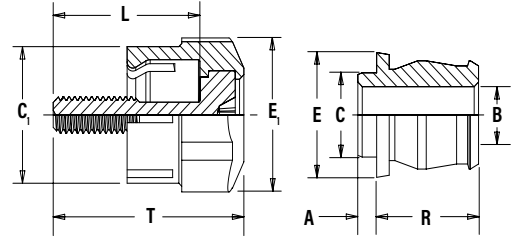
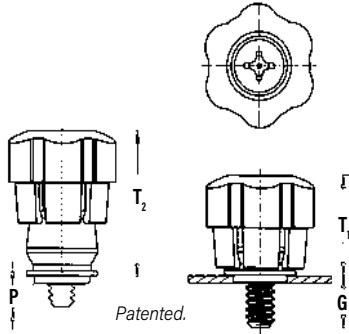
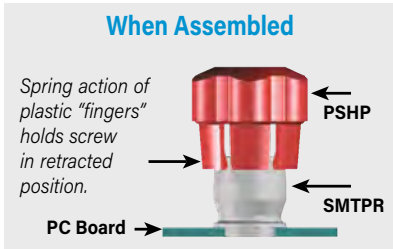

Installation Data page 179. Performance Data page 183.

All dimensions are in inches.

UNIFIED	Thread Size	Screw Part Number			Retainer Part Number	Assembly Dimensions					Screw Dimensions				Retainer Dimensions					
		Type	Thread Code	Screw Length Code		G	P	T <sub>1</sub>	T <sub>2</sub>	Total Radial Float	C <sub>1</sub>	E <sub>1</sub>	L	T	A (Shank) Max.	Min. Sheet Thick.	B ±.003	C Max.	E Nom.	R ±.005
						±.025	±.025	Nom.	Nom.		±.010	±.010	±.015	Nom.						
	.112-40 (#4-40)	PSHP	440	0	.188	.000	.478	.646	.015	.440	.542	.510	.663	.060	.060	.167	.249	.375	.325	
				1																
				0																
				1																
	.138-32 (#6-32)	PSHP	632	0	.188	.000	.478	.646	.020	.440	.542	.510	.663	.060	.060	.167	.249	.375	.325	
				1																
				0																
				1																

All dimensions are in millimeters.

METRIC	Thread Size x Pitch	Screw Part Number			Retainer Part Number	Assembly Dimensions					Screw Dimensions				Retainer Dimensions					
		Type	Thread Code	Screw Length Code		G	P	T <sub>1</sub>	T <sub>2</sub>	Total Radial Float	C <sub>1</sub>	E <sub>1</sub>	L	T	A (Shank) Max.	Min. Sheet Thick.	B ±.008	C Max.	E Nom.	R ±.013
						±.064	±.064	Nom.	Nom.		±.025	±.025	±.038	Nom.						
	M3 x 0.5	PSHP	M3	0	4.78	0	12.14	16.41	.38	11.18	13.77	12.95	16.84	1.53	1.53	4.24	6.33	9.53	8.26	
				1																
				0																
				1																
	M3.5 x 0.6	PSHP	M3.5	0	4.78	0	12.14	16.41	.51	11.18	13.77	12.95	16.84	1.53	1.53	4.24	6.33	9.53	8.26	
				1																
				0																
				1																

**RETAINER** - Packaged on 330 mm recyclable reels of 400 pieces. Tape width is 24 mm. Supplied with Kapton® patch for vacuum pick up. Reels conform to EIA-481.

**SCREW** - Packaged in bags. Retainers and screws are sold separately.

### PART NUMBER DESIGNATION FOR SCREW

**PSHP - 632 - 0 L 001**

Type Thread Code Length Code Cap Style Color Code (Std. Black)

### PART NUMBER DESIGNATION FOR RETAINER

**SMTPR - 6 - 1 ET**

Type Retainer Size Shank Code Finish

### COLOR CAPABILITIES FOR TYPE PSHP SCREW

The colors shown here (codes #002 thru #007) are non-stocked standards and available on special order. Since actual cap colors may vary slightly from those shown here, we recommend that you request samples for color verification. If you require a custom color or you need a "color matched" cap, please contact us.

Std. Black #001 Red #002 Orange #003 Yellow #004 Green #005 Blue #006 Violet #007

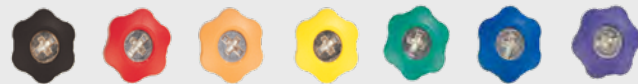

Non-flammable UL 94-V0 plastic caps are available on special order.

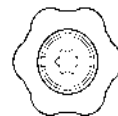

Available with Torx® recess on special order.

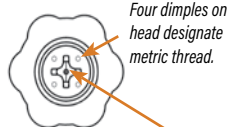

Metal Phillips Recess  
#4-40 & M3 = #1  
#6-32 & M3.5 = #2

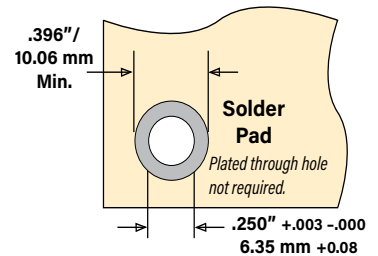

### Stencil Masking Examples



- (1) As with all Class 2A/6g external threads with an additive finish, the maximum major and pitch, after plating, may equal basic sizes and be gauged to Class 3A/4h, per ANSI B1.1, Section 8, Table 3A and ANSI B1.13M, Section 8, Paragraph 8.2.
- (2) See PFM Technical Support section of our website ([www.pemnet.com](http://www.pemnet.com)) for rel.



Get quote >>

Angic Global Solutions

1-888-872-0690 [www.angic.com](http://www.angic.com) 169

<https://www.AngicGlobal.com> Sales@AngicGlobal.com



# PEM® CAPTIVE PANEL SCREWS

## VALUE-ADDED CAPABILITIES

### ATCA Solutions



Use PF11PM captive panel screw and TPXS pin in conjunction to satisfy the requirements of the PICMG 3.0 of the Advanced TCA®.

### Tight Seal Solutions



Consider adding an o-ring to our PEM C.A.P.S.® captive panel screw. When fastened, it provides a tight seal above the panel.

### Nylon Locking Patch



Nylon locking patch is available to be added to any of PEM captive panel screws for applications requiring a locking element.

### Thread-forming Opportunity

PennEngineering is official licensee for REMFORM®, TAPTITE®, PT®, and DELTA PT® fastener products.

REMFORM® and TAPTITE® are trademarks of REMINC®.  
PT® and DELTA PT® are trademarks of EJOT®.

### MATHread® Anti Cross-thread Technology

PennEngineering is a licensee of MATHread® Anti Cross-Threading Technology. This unique design allows the threads to self-align and drive easily with reduced effort. This helps speed assembly, reduce or eliminate failures, repairs, scrap, downtime, and warranty service associated with thread damage. This option is available on most types of PEM captive panel screws.

MATHread® is a registered trademark of MATHread inc.



Anti Cross-Thread Feature



Get quote »

Angic Global Solutions

1-888-872-0690 [www.angic.com](http://www.angic.com) 171

<https://www.AngicGlobal.com> Sales@AngicGlobal.com

## CAPTIVE PANEL SCREW INSTALLATION

### INSTALLATION NOTES

- For best results we recommend using a Haeger® or PEMSERTER® machine for installation of PEM® self-clinching fasteners. Please check our website for more information.
- Visit the Animation Library on our website to view the installation process [for select products](#).

## PF11™/PF12™/PF15™/PF11M™/PF12M™/PF15M™/PEM C.A.P.S.® FASTENERS

- Prepare properly sized mounting hole in sheet. Do not perform any secondary operations such as deburring.
- Place fastener into recessed anvil, and place workpiece (preferably the punch side) over shank of fastener.
- With installation punch and anvil surfaces parallel, apply squeezing force until the shoulder of the retainer comes in contact with the sheet material.

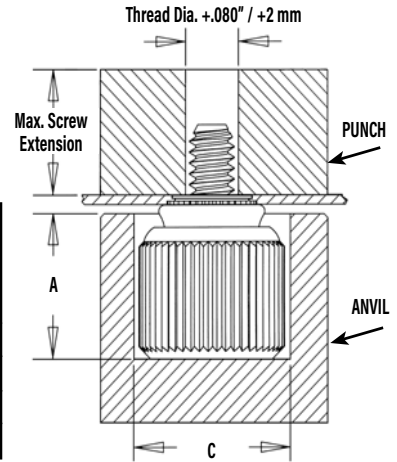

### PEMSERTER® Installation Tooling<sup>(1)</sup>

UNIFIED	Thread Code	Anvil Dimensions (in.)		Anvil Part Number	Punch Part Number
		A ±.002	C ±.002		
	440	.260	.437	8003521	8003518
	632	.390	.468	8003522	8003519
	832	.390	.531	8003523	8003520
	032	.390	.531	8003523	8004350
	0420	.480	.598	8004351	8004352

METRIC	Thread Code	Anvil Dimensions (mm)		Anvil Part Number	Punch Part Number
		A ±0.05	C ±0.05		
	M3	6.6	11.1	8003521	8003518
	M3.5	9.91	11.89	8003522	8003519
	M4	9.91	13.49	8003523	8003520
	M5	9.91	13.49	8003523	8004350
	M6	12.19	15.19	8004351	8004352

(1) Punches and anvils should be hardened.

## PF11MF™/PF12MF™ FASTENERS (flare-mount installation)

- Prepare properly sized mounting hole in sheet with countersink.
- Place fastener into recessed anvil, and place workpiece over shank of fastener.
- With installation punch and anvil surfaces parallel, apply squeezing force to flare the retainer of the fastener.

### PEMSERTER® Installation Tooling<sup>(1)</sup>

UNIFIED	Thread Code	Anvil Dimensions (in.)		Punch Dimensions (in.)		Anvil Part No.	Punch Part No.
		A ±.002	C ±.002	E +.003 -.000	F ±.002		
	440	.260	.437	.123	.133	8003521	8013670
	632	.390	.468	.143	.156	8003522	8013671
	832	.390	.531	.202	.210	8003523	8013672
	032	.390	.531	.202	.210	8003523	8013672
	0420	.480	.598	.255	.264	8004351	8013674

METRIC	Thread Code	Anvil Dimensions (mm)		Punch Dimensions (mm)		Anvil Part No.	Punch Part No.
		A ±0.05	C ±0.05	E +0.08	F ±0.05		
	M3	6.6	11.1	3.12	3.38	8003521	8013670
	M4	9.91	13.49	5.13	5.33	8003523	8013672
	M5	9.91	13.49	5.13	5.33	8003523	8013672
	M6	12.19	15.19	6.48	6.71	8004351	8013674

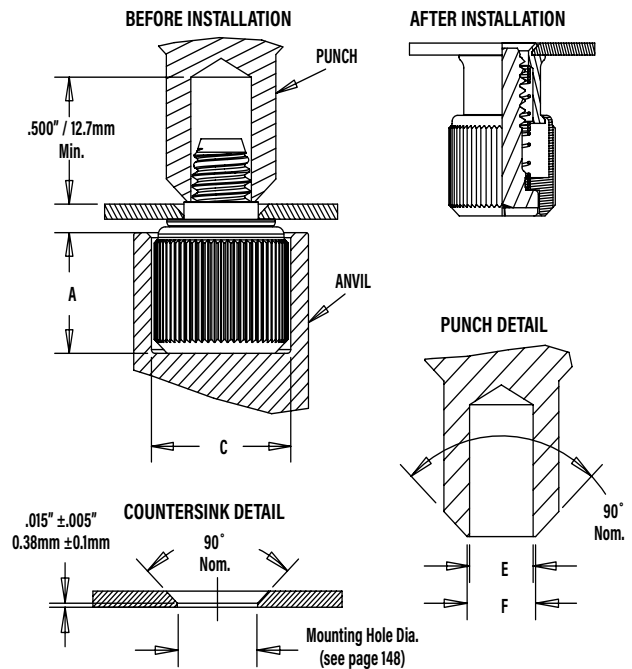

(1) Punches and anvils should be hardened.

# PEM® CAPTIVE PANEL SCREWS

## PF11MW™/PF12MW™ FASTENERS

1. Prepare properly sized mounting hole in sheet.
2. Place fastener into recessed anvil, place workpiece over shank of fastener, then place the washer over the shank of the fastener.
3. With installation punch and anvil surfaces parallel, apply squeezing force with flaring punch.

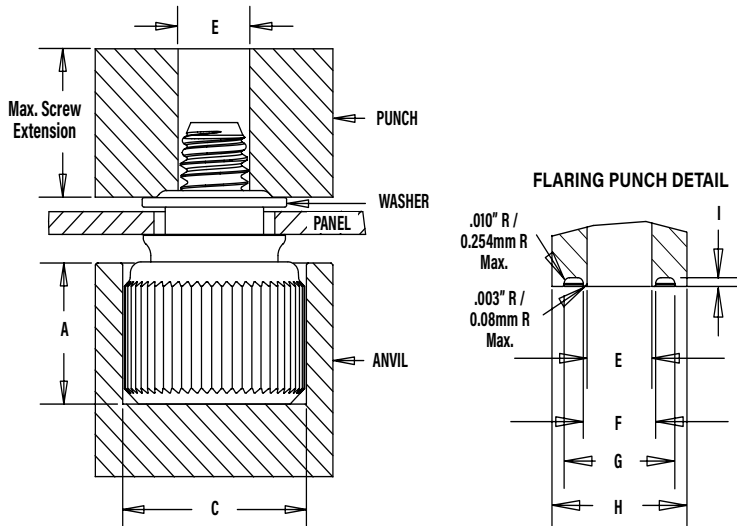

### PEMSERTER® Installation Tooling<sup>(1)</sup>

UNIFIED	Thread Code	Anvil Dimensions (in.)		Punch Dimensions (in.)					Anvil Part No.	Punch Part No.
		A ±.002	C ±.001	E +.003 -.000	F ±.001	G ±.003	H Min.	I ±.004		
	440	.260	.437	.120	.135	.204	.250	.015	8003521	8014304
	632	.390	.468	.140	.159	.249	.300	.015	8003522	8014305
	832	.390	.531	.201	.217	.340	.400	.028	8003523	8014306
	032	.390	.531	.201	.217	.340	.400	.028	8003523	8014306
	0420	.480	.598	.252	.271	.430	.500	.028	8004351	8014307

METRIC	Thread Code	Anvil Dimensions (mm)		Punch Dimensions (mm)					Anvil Part No.	Punch Part No.
		A ±0.05	C ±0.03	E +0.08	F ±0.03	G ±0.08	H Min.	I ±0.1		
	M3	6.6	11.1	3.05	3.43	5.18	6.35	.381	8003521	8014304
	M3.5	9.9	11.9	3.56	4.04	6.32	7.62	.381	8003522	8014305
	M4	9.9	13.5	5.11	5.51	8.64	10.16	.711	8003523	8014306
	M5	9.9	13.5	5.11	5.51	8.64	10.16	.711	8003523	8014306
	M6	12.2	15.2	6.4	6.88	10.92	12.7	.711	8004351	8014307

(1) Punches and anvils should be hardened.

## PFHV™ FASTENERS

1. Prepare properly sized mounting hole in sheet. Do not perform any secondary operations such as deburring.
2. Place fastener into recessed anvil, and place workpiece (preferably the punch side) over shank of fastener.
3. With installation punch and anvil surfaces parallel, apply squeezing force until the shoulder of the retainer comes in contact with the sheet material.

### PEMSERTER® Installation Tooling<sup>(1)</sup>

UNIFIED	Thread Code	Anvil Dimensions (in.)		Anvil Part Number	Punch Part Number
		A ±.002	C ±.002		
	440	.220	.285	8004688	970200009400
	632	.250	.301	8004689	8015656
	832	.285	.332	8005439	970200230400

METRIC	Thread Code	Anvil Dimensions (mm)		Anvil Part Number	Punch Part Number
		A ±0.05	C ±0.05		
	M3	5.59	7.24	8004688	970200020400
	M3.5	6.35	7.65	8004689	8015656
	M4	7.24	8.43	8005439	970200230400

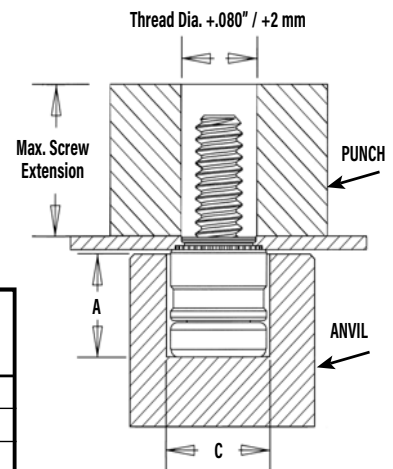

(1) Punches and anvils should be hardened.



Get quote >>

Angic Global Solutions

1-888-872-0690 [www.angic.com](http://www.angic.com) 173

<https://www.AngicGlobal.com> Sales@AngicGlobal.com

# PEM® CAPTIVE PANEL SCREWS

## PF7M™ FASTENERS

1. Prepare properly sized mounting hole in sheet. Do not perform any secondary operations such as deburring.
2. Place fastener into recessed anvil, and place workpiece (preferably the punch side) over the shank of fastener.
3. With installation punch and anvil surfaces parallel, apply squeezing force until the shoulder of the retainer comes in contact with the sheet material.

### PEMSERTER® Installation Tooling<sup>(1)</sup>

UNIFIED	Thread Code	Anvil Dimensions (in.)		Anvil Part Number	Punch Part Number
		A ±.002	C ±.002		
	440	.319	.290	8016175	8003518
	632	.333	.330	8016176	8003519
	832	.353	.385	8016177	8003520

METRIC	Thread Code	Anvil Dimensions (mm)		Anvil Part Number	Punch Part Number
		A ±0.05	C ±0.05		
	M3	8.1	7.34	8016175	8003518
	M4	8.9	9.8	8016177	8003520

(1) Punches and anvils should be hardened.

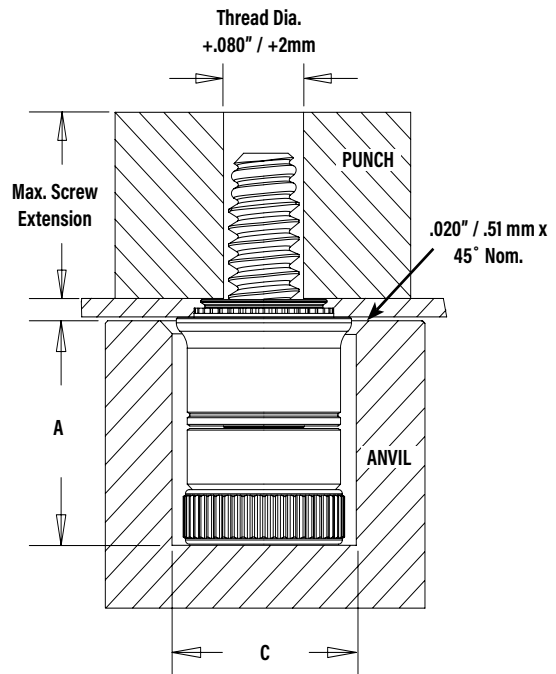

## PF7MF™ FASTENERS (flare-mount installation)

1. Prepare properly sized mounting hole in sheet with countersink. Do not perform any secondary operations such as deburring.
2. Place fastener into recessed anvil, and place workpiece over the shank of fastener.
3. With installation punch and anvil surfaces parallel, apply squeezing force to flare the retainer of the fastener.

### PEMSERTER® Installation Tooling<sup>(1)</sup>

UNIFIED	Thread Code	Anvil Dimensions (in.)		Punch Dimensions (in.)		Anvil Part No.	Punch Part No.
		A ±.002	C ±.002	E +.003 -.000	F ±.002		
	440	.319	.290	.123	.133	8016175	8013670
	632	.333	.330	.143	.156	8016176	8013671
	832	.353	.385	.202	.210	8016177	8013672

METRIC	Thread Code	Anvil Dimensions (mm)		Punch Dimensions (mm)		Anvil Part No.	Punch Part No.
		A ±0.05	C ±0.05	E +0.08	F ±0.05		
	M3	8.1	7.34	3.12	3.38	8016175	8013670
	M4	8.9	9.8	5.13	5.33	8016177	8013672

(1) Punches and anvils should be hardened.

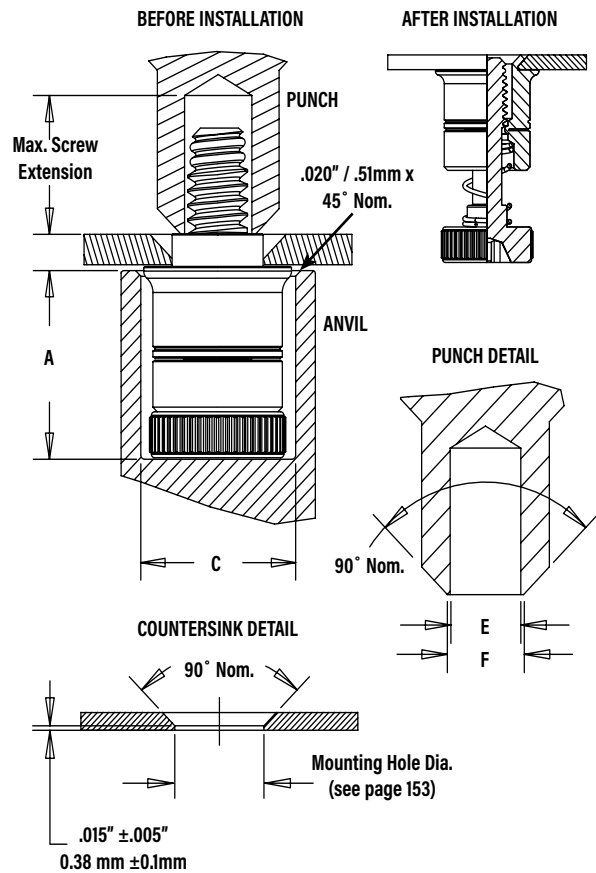

# PEM® CAPTIVE PANEL SCREWS

## PF30™/PF31™/PF32™ FASTENERS

1. Prepare properly sized mounting hole in sheet. Do not perform any secondary operations such as deburring.
2. Place fastener into recessed anvil, and place workpiece (preferably the punch side) over shank of fastener.
3. With installation punch and anvil surfaces parallel, apply squeezing force until the shoulder of the retainer comes in contact with the sheet material.

### PEMSERTER® Installation Tooling<sup>(1)</sup>

UNIFIED	Thread Code	Anvil Dimensions (in.)		Anvil Part Number	Punch Part Number
		A ±.002	C ±.002		
	440	.295	.421	975201060	975200060
632	.295	.453	975201061	975200061	
832	.310	.484	975201062	975200062	
032	.310	.546	975201063	975200063	
0420	.365	.640	975201064	975200064	

METRIC	Thread Code	Anvil Dimensions (mm)		Anvil Part Number	Punch Part Number
		A ±0.05	C ±0.05		
	M3	7.49	10.69	975201060	975200060
M4	7.87	12.29	975201062	975200062	
M5	7.87	13.87	975201063	975200063	
M6	9.27	16.26	975201064	975200064	

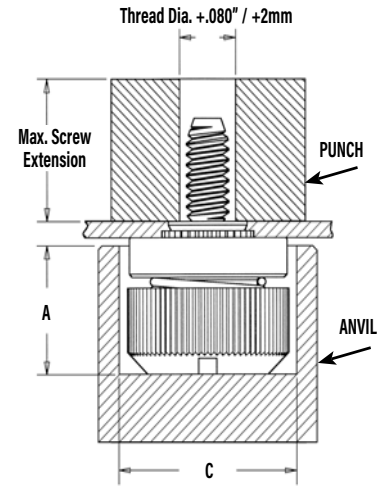

(1) Punches and anvils should be hardened.

## PF50™/PF51™/PF52™/PF60™/PF61™/PF62™ FASTENERS

1. Prepare properly sized mounting hole in sheet. Do not perform any secondary operations such as deburring.
2. Place fastener into recessed anvil, and place workpiece (preferably the punch side) over shank of fastener.
3. With installation punch and anvil surfaces parallel, apply squeezing force until the shoulder of the retainer comes in contact with the sheet material.

### PEMSERTER® Installation Tooling<sup>(1)</sup>

UNIFIED	Thread Code	Anvil Dimensions (in.)		Anvil Part Number	Punch Part Number
		A ±.002	C ±.002		
	440	.295	.421	975201060	975200060
632	.295	.453	975201061	975200061	
832	.310	.484	975201062	975200062	
032	.310	.546	975201063	975200063	
0420	.365	.640	975201064	975200064	

METRIC	Thread Code	Anvil Dimensions (mm)		Anvil Part Number	Punch Part Number
		A ±0.05	C ±0.05		
	M3	7.49	10.69	975201060	975200060
M3.5	7.49	11.51	975201061	975200061	
M4	7.87	12.29	975201062	975200062	
M5	7.87	13.87	975201063	975200063	
M6	9.27	16.26	975201064	975200064	

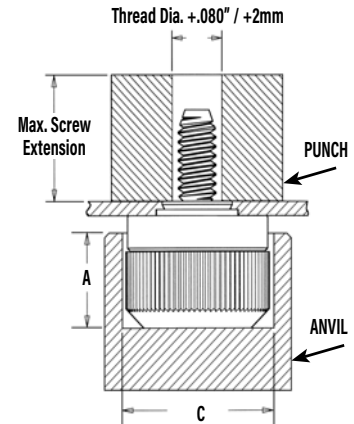

(1) Punches and anvils should be hardened.



Get quote >>

Angic Global Solutions

1-888-872-0690 [www.angic.com](http://www.angic.com) 175

<https://www.AngicGlobal.com> Sales@AngicGlobal.com

# PEM® CAPTIVE PANEL SCREWS

## PFC4™ FASTENERS

1. Prepare properly sized mounting hole in sheet. Do not perform any secondary operations such as deburring.
2. Place fastener into recessed anvil, and place workpiece (preferably the punch side) over shank of fastener.
3. With installation punch and anvil surfaces parallel, apply squeezing force until the shoulder of the retainer comes in contact with the sheet material.

### Installation Requirements

1. Sheet hardness must be less than 88 on the Rockwell "B" scale.
2. Hole punch should be kept sharp to minimize work hardening around hole.
3. Fastener should be installed in punch side of hole.
4. Fastener should not be installed near bends or other highly cold worked areas where sheet hardness may be greater than 88 on the Rockwell "B" scale.

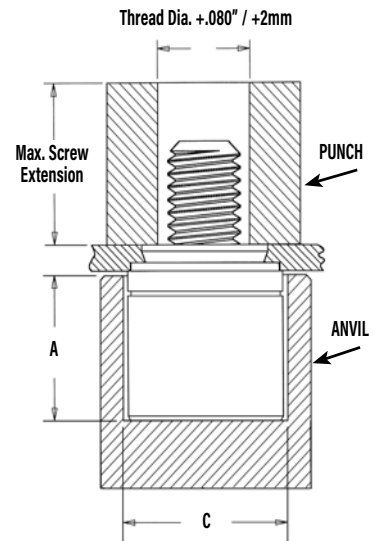

### PEMSERTER® Installation Tooling<sup>(1)</sup>

UNIFIED	Thread Code	Anvil Dimensions (in.)		Anvil Part Number	Punch Part Number
		A ±.002	C ±.002		
	440	.345	.358	975200027	975200060
632	.345	.390	975201243	975200061	
832	.435	.421	975200029	975200062	
032	.435	.452	975201244	975200063	

METRIC	Thread Code	Anvil Dimensions (mm)		Anvil Part Number	Punch Part Number
		A ±0.05	C ±0.05		
	M3	8.76	9.09	975200027	975200060
M4	11.05	10.69	975200029	975200062	
M5	11.05	11.48	975201244	975200063	

(1) Punches and anvils should be hardened.

## PFC2P™ FASTENERS

1. Prepare properly sized mounting hole in sheet. Do not perform any secondary operations such as deburring.
2. Place fastener into recessed anvil, and place workpiece (preferably the punch side) over shank of fastener.
3. With installation punch and anvil surfaces parallel, apply squeezing force until the shoulder of the retainer comes in contact with the sheet material.

### PEMSERTER® Installation Tooling<sup>(1)</sup>

UNIFIED	Thread Code	Anvil Dimensions (in.)		Anvil Part Number	Punch Part Number
		A ±.002	C ±.002		
	440	.345	.323	975200026	975200060
632	.345	.358	975200027	975200061	
832	.435	.386	975200028	975200062	
032	.435	.421	975200029	975200063	

METRIC	Thread Code	Anvil Dimensions (mm)		Anvil Part Number	Punch Part Number
		A ±0.05	C ±0.05		
	M3	8.76	8.2	975200026	975200060
M4	11.05	9.8	975200028	975200062	
M5	11.05	10.69	975200029	975200063	

(1) Punches and anvils should be hardened.

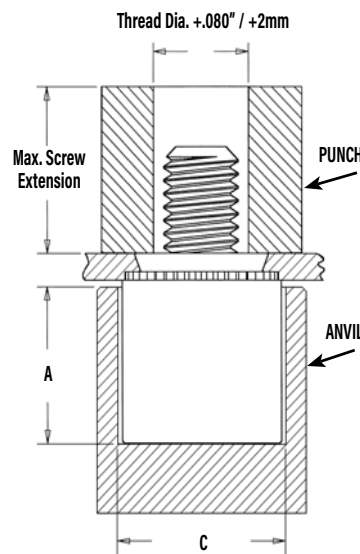

# PEM® CAPTIVE PANEL SCREWS

## PFC2™/PFS2™ FASTENERS

1. Prepare properly sized mounting hole in sheet. Do not perform any secondary operations such as deburring.
2. Place fastener into recessed anvil, and place workpiece (preferably the punch side) over shank of fastener.
3. With installation punch and anvil surfaces parallel, apply squeezing force until the shoulder of the retainer comes in contact with the sheet material.

### PEMSERTER® Installation Tooling<sup>(1)</sup>

UNIFIED	Thread Code	Anvil Dimensions (in.)		Anvil Part Number	Punch Part Number
		A ±.002	C ±.002		
	440	.345	.323	975200026	975200060
632	.345	.358	975200027	975200061	
832	.435	.386	975200028	975200062	
032	.435	.421	975200029	975200063	
0420	.565	.484	975200030	975200064	

METRIC	Thread Code	Anvil Dimensions (mm)		Anvil Part Number	Punch Part Number
		A ±0.05	C ±0.05		
	M3	8.76	8.2	975200026	975200060
M4	11.05	9.8	975200028	975200062	
M5	11.05	10.69	975200029	975200063	
M6	14.35	12.29	975200030	975200064	

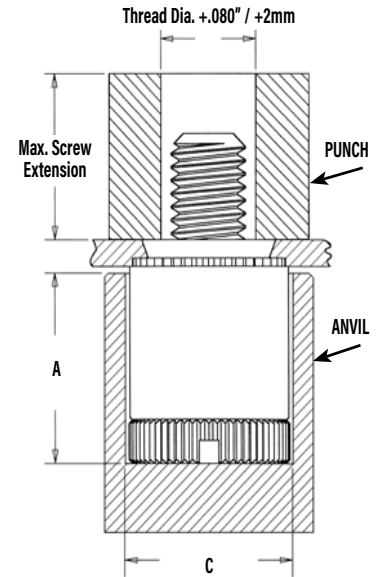

(1) Punches and anvils should be hardened.

## PTL2™/PSL2™ FASTENERS

1. Prepare properly sized mounting hole in sheet. Do not perform any secondary operations such as deburring.
2. Place fastener into recessed anvil, and place workpiece (preferably the punch side) over shank of fastener.
3. With installation punch and anvil surfaces parallel, apply squeezing force until the shoulder of the retainer comes in contact with the sheet material.

### PEMSERTER® Installation Tooling<sup>(1)</sup>

UNIFIED	Type	Anvil Dimensions (in.)		Anvil Part Number	Punch Part Number
		A ±.002	C ±.002		
	PTL2	.580	.520	975201245	970200013300
PSL2	.490	.520	8021146	970200013300	

METRIC	Type	Anvil Dimensions (mm)		Anvil Part Number	Punch Part Number
		A ±0.05	C ±0.05		
	PTL2	14.86	13.21	975201245	970200013300
PSL2	12.47	13.21	8021146	970200013300	

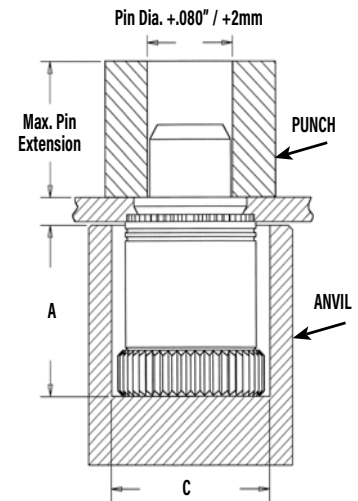

(1) Punches and anvils should be hardened.

## PFK™ FASTENERS

1. Prepare properly sized mounting hole in board.
2. Place fastener into recessed anvil, and place workpiece over shank of fastener.
3. With installation punch and anvil surfaces parallel, apply squeezing force until the shoulder of the retainer comes in contact with the board.

### PEMSERTER® Installation Tooling<sup>(1)</sup>

UNIFIED	Thread Code	Anvil Dimensions (in.)		Anvil Part Number	Punch Part Number
		A ±.002	C ±.002		
	440	.320	.323	975200026	975200060
632	.320	.358	975200027	975200061	

METRIC	Thread Code	Anvil Dimensions (mm)		Anvil Part Number	Punch Part Number
		A ±0.05	C ±0.05		
	M3	8.13	8.2	975200026	975200060

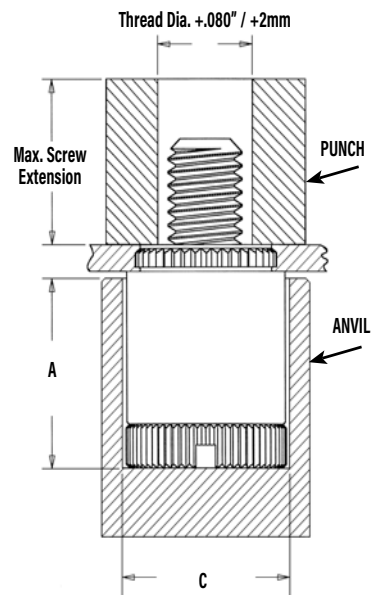

(1) Punches and anvils should be hardened.



Get quote >>

Angic Global Solutions

1-888-872-0690 [www.angic.com](http://www.angic.com) 177

<https://www.AngicGlobal.com> Sales@AngicGlobal.com

## SCBR™ FASTENERS

1. Prepare properly sized mounting hole in sheet. Do not perform any secondary operations such as deburring. If the hole is punched, be sure to install fastener into punched side of hole.
2. Assemble spring on screw by rotating spring counter clockwise and position assembly into recessed magnetic punch.
3. Position hole in workpiece over retractable anvil pin.
4. With installation punch and anvil surfaces parallel, apply squeezing force on top of the screw head and the underside of the sheet material. The squeezing action forces the displacer of the screw into the sheet, causing it to reduce the mounting hole diameter and captivate the screw.

### PEMSERTER® Installation Tooling<sup>(1)</sup>

UNIFIED	Thread Code	Installation Tooling Dimensions (in.)			Anvil Part Number	Magnetic Punch Part Number <sup>(2)</sup>
		C	J	K		
	440	.113 - .116	.354 - .357	.035	970200048300	8016210
	632	.139 - .142	.387 - .390	.035	970200052300	8016211
	832	.165 - .168	.416 - .419	.035	970200054300	8016212

METRIC	Thread Code	Installation Tooling Dimensions (mm)			Anvil Part Number	Magnetic Punch Part Number <sup>(2)</sup>
		C	J	K		
	M3	3.03 - 3.11	9.25 - 9.32	0.89	970200049300	8016213
	M4	4.03 - 4.11	10.8 - 10.9	0.89	970200053300	8016214

(1) Punches and anvils should be hardened.

(2) Pneumatic punch may also be used. Please contact our PEMSERTER tooling division for punch part numbers.

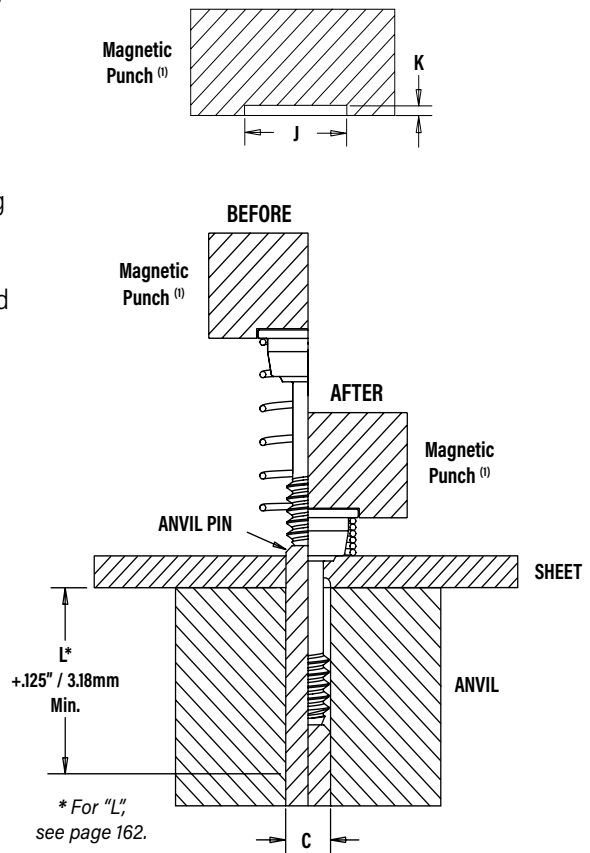

## SCB™/SCBJ™ FASTENERS

1. Prepare properly sized mounting hole in sheet.
2. Place the fastener through mounting hole and into anvil. A flat or recessed punch can be used.
3. With installation punch and anvil surfaces parallel, apply squeezing force to the top of the screw head and the underside of the sheet material. The squeezing action forces the shoulder of the screw into the sheet, displacing sheet material, causing it to fill the void under the head and shoulder of the screw.

### PEMSERTER® Installation Tooling<sup>(1)</sup>

UNIFIED	Thread Code	Installation Tooling Dimensions (in.)		
		C	E	H
	440	.113 - .116	.270 - .280	.073 - .074
	632	.139 - .142	.308 - .318	.073 - .074

METRIC	Thread Code	Installation Tooling Dimensions (mm)		
		C	E	H
	M3	3.03 - 3.11	6.86 - 7.11	1.85 - 1.88
	M4	4.03 - 4.11	8.53 - 8.79	1.85 - 1.88

(1) Punches and anvils should be hardened.

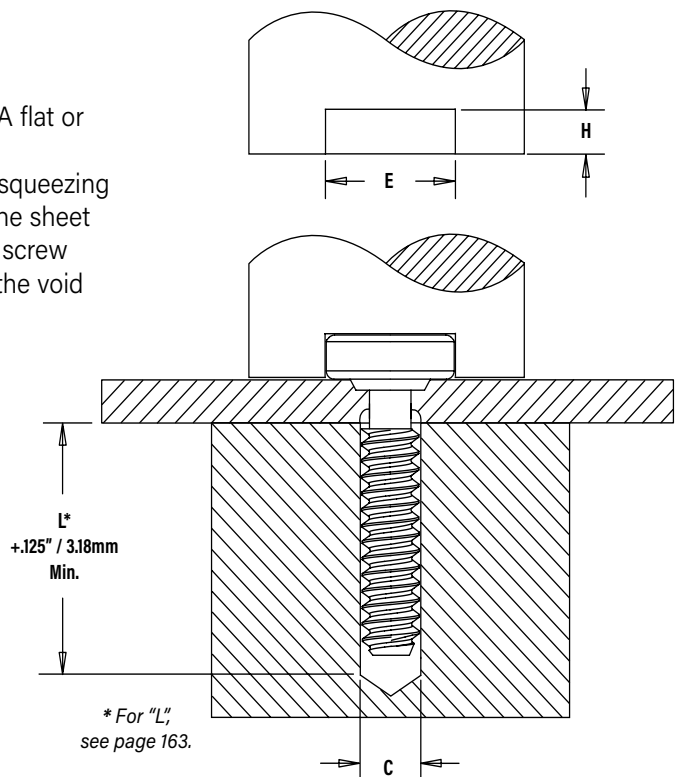

## HSCB™ FASTENER INTO HEAT SINK

1. Prepare properly sized mounting hole in heat sink. Do not perform any secondary operations such as deburring. If the hole is punched, be sure to install the fastener into the punch side of the hole.
2. Place the head of the screw into the recess of the installation anvil and position assembly into recessed magnetic punch.
3. Place the spring over the shoulder of the screw, maintaining concentricity.
4. Position the heat sink mounting hole over the screw.
5. Bring the heat sink down over the screw and onto the shoulder of the screw.
6. With installation punch and anvil surfaces parallel, apply a squeezing force to the heat sink and the head of the screw. The squeezing action forces the displacer of the screw into the heat sink, causing it to reduce the mounting hole diameter and captivate the screw and spring.

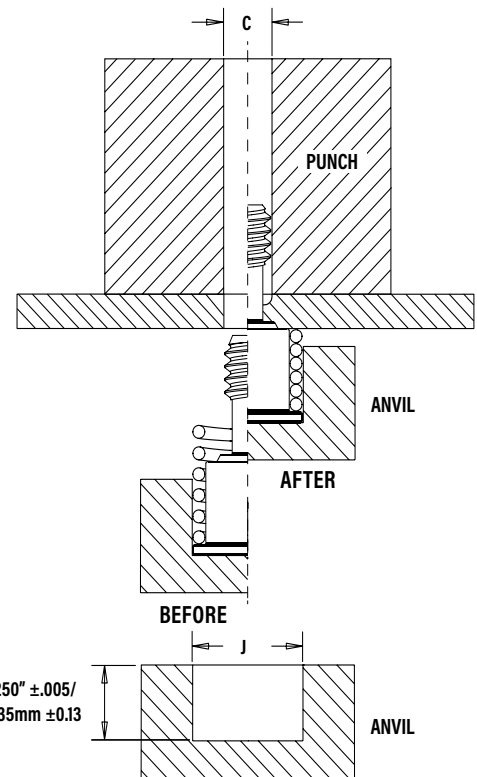

## PEMSERTER® Installation Tooling<sup>(1)</sup>

UNIFIED	Thread Code	Installation Tooling Dimensions (in.)		Anvil Part Number	Punch Part Number
		C	J		
	440	.113 - .116	.322 - .324	8018043	97020006300
632	.139 - .142	.362 - .364	8018044	97020007300	

METRIC	Thread Code	Installation Tooling Dimensions (mm)		Anvil Part Number	Punch Part Number
		C	J		
	M3	3.03 - 3.11	8.43 - 8.48	8018045	970200229300

(1) Punches and anvils should be hardened.

## HSR™ NUT/STANDOFF

1. Prepare properly sized mounting hole in board.
2. Place fastener into the anvil hole and place the mounting hole over the shank of the fastener as shown in drawing.
3. With installation punch and anvil surfaces parallel, apply squeezing force until shoulder contacts the board.

## PEMSERTER® Installation Tooling<sup>(1)</sup>

UNIFIED	Thread Code	Anvil Dimensions (in.)		Anvil Part Number	Punch Part Number
		A	P ±.005		
	HSR-440	.228 - .231	.115	8023699	975200048
HSR-632	.290 - .293	.115	8023701	975200048	

METRIC	Thread Code	Anvil Dimensions (mm)		Anvil Part Number	Punch Part Number
		A	P ±0.13		
	HSR-M3	5.8 - 5.86	2.92	8023700	975200048

(1) Punches and anvils should be hardened.

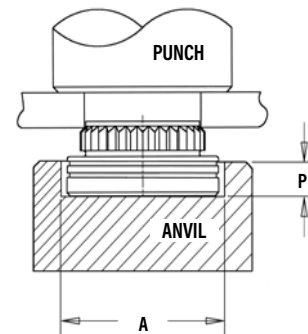

## FINAL ASSEMBLY

Once the screw and spring are captivated, assemble the heat sink to the circuit board by tightening the screw into the receptacle nut or standoff until the audible "click" is heard. The screw will continue to rotate, but will no longer be engaged in the threads or continue to actively tighten.

# PEM® CAPTIVE PANEL SCREWS

## PR10™ FASTENERS

1. Prepare properly sized mounting hole in sheet. Do not perform any secondary operations such as deburring.
2. Place fastener into the mounting hole.
3. With installation punch and anvil surfaces parallel, apply squeezing force until the retainer is flush in the sheet.

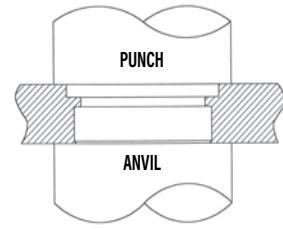

## N10™ FASTENERS

1. Prepare properly sized mounting hole in sheet. Do not perform any secondary operations such as deburring.
2. Place fastener into recessed anvil, and place workpiece (preferably the punch side) over shank of fastener.
3. With installation punch and anvil surfaces parallel, apply squeezing force until the shoulder of the nut comes in contact with the sheet material.

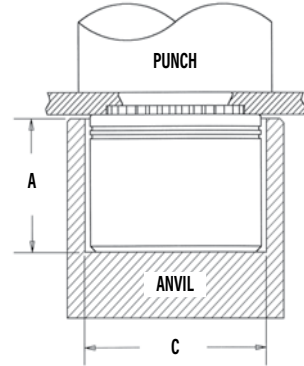

### PEMSERTER® Installation Tooling<sup>(1)</sup>

UNIFIED	Thread Code	Anvil Dimensions (in.)		Anvil Part Number	Punch Part Number
		A ±.002	C ±.002		
	440	.225	.298	8006124	975200048
	632	.225	.329	8006735	975200048
	832	.225	.361	8006736	975200048
	032	.225	.392	8006174	975200048

METRIC	Thread Code	Anvil Dimensions (mm)		Anvil Part Number	Punch Part Number
		A ±0.05	C ±0.05		
	M3	5.72	7.57	8006124	975200048
	M4	5.72	9.17	8006736	975200048
	M5	5.72	9.6	8006174	975200048

(1) Punches and anvils should be hardened.

## SMTPLSM™ CAPTIVE PANEL SCREWS

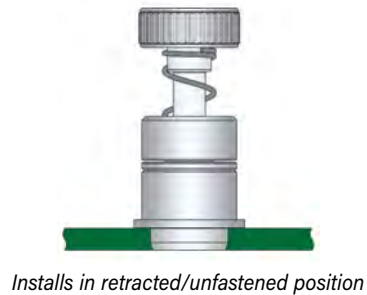
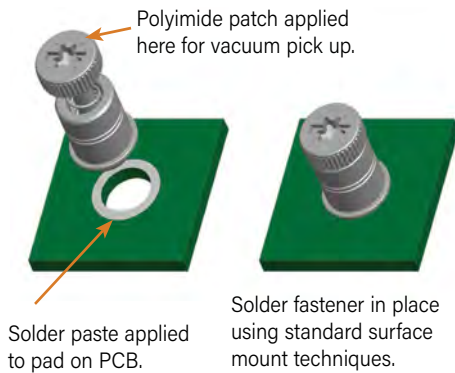

## SMTPF™ RETAINER

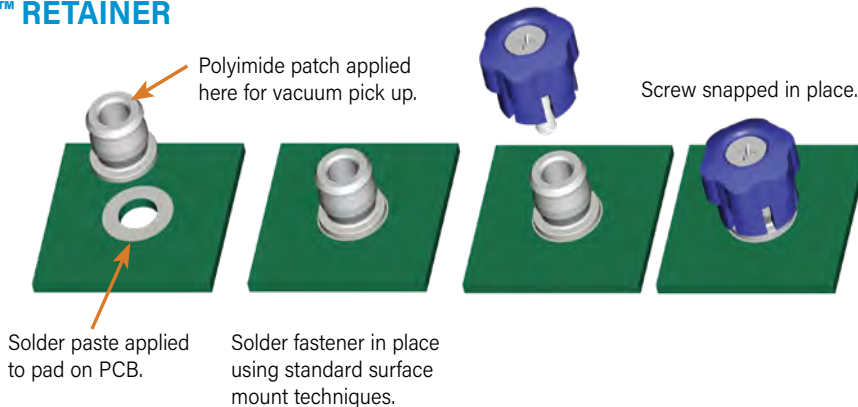

# PEM® CAPTIVE PANEL SCREWS

## CAPTIVE PANEL SCREW PERFORMANCE DATA<sup>(1)</sup>

### PF11™/PF12™/PF15™/PF11M™/PF12M™/PF15M™/PEM C.A.P.S.® FASTENERS

UNIFIED	Type	Thread Code	Test Sheet Material			
			Aluminum		Cold-Rolled Steel	
			Installation (lbs.)	Retainer Pushout (lbs.)	Installation (lbs.)	Retainer Pushout (lbs.)
PF11	440	1500	80	2500	145	
	632	2000	95	3500	150	
PF12	832	3000	100	4500	160	
PF15	032	3000	100	4500	160	
	0420	3500	105	5000	195	

METRIC	Type	Thread Code	Test Sheet Material			
			Aluminum		Cold-Rolled Steel	
			Installation (kN)	Retainer Pushout (N)	Installation (kN)	Retainer Pushout (N)
PF11	M3	6.7	355	11.1	645	
	M4	13.3	445	20	710	
PF12	M5	13.3	445	20	710	
	M6	15.6	465	22.2	865	

### PF11MF™ FASTENERS

UNIFIED	Type	Thread Code	Installation (lbs.)	Retainer Pullout (lbs.)
	PF11MF	440	250	81
		632	300	175
		832	350	180
		032	350	180
		0420	400	200

METRIC	Type	Thread Code	Installation (kN)	Retainer Pullout (N)
	PF11MF	M3	1.1	360
		M4	1.5	800
		M5	1.5	800
		M6	2	890

### PF11MW™ FASTENERS

UNIFIED	Type	Thread Code	Test Sheet Material	
			.060" Cold-rolled Steel	
			Swaging Force (lbs.)	Retainer Pullout (lbs.)
PF11MW	440	350	112	
	632	400	138	
	832	700	202	
	032	700	202	
	0420	900	212	

METRIC	Type	Thread Code	Test Sheet Material	
			1.52mm Cold-rolled Steel	
			Swaging Force (N)	Retainer Pullout (N)
PF11MW	M3	1557	499	
	M3.5	1779	612	
	M4	3114	897	
	M5	3114	897	
	M6	4003	945	

### PFHV™ FASTENERS

UNIFIED	Type	Thread Code	Test Sheet Material			
			Aluminum		Cold-Rolled Steel	
			Installation (lbs.)	Retainer Pushout (lbs.)	Installation (lbs.)	Retainer Pushout (lbs.)
PFHV	440	1700	108	2200	118	
	632	1850	117	2400	128	
	832	2100	134	2700	147	

METRIC	Type	Thread Code	Test Sheet Material			
			Aluminum		Cold-Rolled Steel	
			Installation (kN)	Retainer Pushout (N)	Installation (kN)	Retainer Pushout (N)
PFHV	M3	8.1	516	10.5	564	
	M3.5	8.8	561	11.4	614	
	M4	9.4	599	12.1	656	

(1) Published installation forces are for general reference. Actual set-up and confirmation of complete installation should be made by observing proper seating of fastener as described in the installation steps. Other performance values reported are averages when all proper installation parameters and procedures are followed. Variations in mounting hole size, sheet material, and installation procedure may affect performance. Performance testing this product in your application is recommended. We will be happy to provide technical assistance and/or samples for this purpose.



Get quote >>

Angic Global Solutions

1-888-872-0690 [www.angic.com](http://www.angic.com) 181

<https://www.AngicGlobal.com> Sales@AngicGlobal.com

# PEM® CAPTIVE PANEL SCREWS

## PF7M™ FASTENERS

UNIFIED	Type	Thread Code	Rec. Tightening Torque (in. lbs.) (2)	Min. Screw Tensile (lbs.)	Test Sheet Material			
					Aluminum		Cold-rolled Steel	
					Installation (lbs.)	Retainer Pushout (lbs.)	Installation (lbs.)	Retainer Pushout (lbs.)
	PF7M	440	4.5	580	1500	80	2500	145
	PF7M	632	8.6	855	2000	95	3500	150
	PF7M	832	15.6	1300	3000	100	4500	160

METRIC	Type	Thread Code	Rec. Tightening Torque (N · m) (2)	Min. Screw Tensile (N)	Test Sheet Material			
					5052-H34 Aluminum		Cold-rolled Steel	
					Installation (kN)	Retainer Pushout (N)	Installation (kN)	Retainer Pushout (N)
	PF7M	M3	0.66	2900	6.7	355	11.1	645
	PF7M	M4	1.57	5010	13.3	445	20	710

## PF7MF™ FASTENERS

UNIFIED	Type	Thread Code	Rec. Tightening Torque (in. lbs.) (2)	Min. Screw Tensile (lbs.)	Installation (lbs.)	Retainer Pullout (lbs.)
	PF7MF	440	4.5	580	250	81
	PF7MF	632	8.6	855	300	175
	PF7MF	832	15.6	1300	350	180

METRIC	Type	Thread Code	Rec. Tightening Torque (N·m) (2)	Min. Screw Tensile (N)	Installation (kN)	Retainer Pullout (N)
	PF7MF	M3	0.66	2900	1.1	360
	PF7MF	M4	1.57	5010	1.5	800

## PF30™/PF31™/PF32™ FASTENERS

UNIFIED	Type	Thread Code	Test Sheet Material			
			Aluminum		Cold-Rolled Steel	
			Installation (lbs.)	Retainer Pushout (lbs.)	Installation (lbs.)	Retainer Pushout (lbs.)
PF30	440	2200	64	5000	90	
PF31	440	2200	105	5000	110	
PF32	440	2200	185	5000	300	
PF30	632	2400	66	5500	90	
PF31	632	2400	105	5500	130	
PF32	632	2400	190	5500	300	
PF30	832	2800	68	6000	90	
PF31	832	2800	110	6000	130	
PF32	832	2800	200	6000	300	
PF30	032	3500	72	8000	95	
PF31	032	3500	150	8000	160	
PF32	032	3500	260	8000	425	
PF32	0420	4300	320	12000	450	

METRIC	Type	Thread Code	Test Sheet Material			
			Aluminum		Cold-Rolled Steel	
			Installation (kN)	Retainer Pushout (N)	Installation (kN)	Retainer Pushout (N)
PF30	M3	9.8	285	22.2	400	
PF31	M3	9.8	465	22.2	489	
PF32	M3	9.8	823	22.2	1334	
PF30	M4	12.5	302	26.7	400	
PF31	M4	12.5	489	26.7	578	
PF32	M4	12.5	890	26.7	1334	
PF30	M5	15.6	320	35.6	423	
PF31	M5	15.6	667	35.6	712	
PF32	M5	15.6	1156	35.6	1890	
PF32	M6	19.1	1423	53.4	2002	

(1) Published installation forces are for general reference. Actual set-up and confirmation of complete installation should be made by observing proper seating of fastener as described in the installation steps. Other performance values reported are averages when all proper installation parameters and procedures are followed. Variations in mounting hole size, sheet material, and installation procedure may affect performance. Performance testing this product in your application is recommended. We will be happy to provide technical assistance and/or samples for this purpose.

(2) Torque values shown will produce a preload of 70% minimum tensile with nut factor "k" equal to .1

# PEM® CAPTIVE PANEL SCREWS

## PF50™/PF51™/PF52™/PF60™/PF61™/PF62™ FASTENERS

UNIFIED	Type	Thread Code	Test Sheet Material			
			Aluminum		Cold-Rolled Steel	
			Installation (lbs.)	Retainer Pushout (lbs.)	Installation (lbs.)	Retainer Pushout (lbs.)
PF50/PF60	440	2200	64	5000	90	
PF51/PF61	440	2200	105	5000	110	
PF52/PF62	440	2200	185	5000	300	
PF50/PF60	632	2400	66	5500	90	
PF51/PF61	632	2400	105	5500	130	
PF52/PF62	632	2400	190	5500	300	
PF50/PF60	832	2800	68	6000	90	
PF51/PF61	832	2800	110	6000	130	
PF52/PF62	832	2800	200	6000	300	
PF50/PF60	032	3500	72	8000	95	
PF51/PF61	032	3500	150	8000	160	
PF52/PF62	032	3500	260	8000	425	
PF52/PF62	0420	4300	320	12000	450	

METRIC	Type	Thread Code	Test Sheet Material			
			Aluminum		Cold-Rolled Steel	
			Installation (kN)	Retainer Pushout (N)	Installation (kN)	Retainer Pushout (N)
PF50/PF60	M3	9.8	285	22.2	400	
PF51/PF61	M3	9.8	465	22.2	489	
PF52/PF62	M3	9.8	823	22.2	1334	
PF50/PF60	M3.5	10.7	294	24.4	400	
PF51/PF61	M3.5	10.7	465	24.4	578	
PF52/PF62	M3.5	10.7	845	24.4	1334	
PF50/PF60	M4	12.5	302	26.7	400	
PF51/PF61	M4	12.5	489	26.7	578	
PF52/PF62	M4	12.5	890	26.7	1334	
PF50/PF60	M5	15.6	320	35.6	423	
PF51/PF61	M5	15.6	667	35.6	712	
PF52/PF62	M5	15.6	1156	35.6	1890	
PF52/PF62	M6	19.1	1423	53.4	2002	

## PFC4™ FASTENERS

UNIFIED	Type	Thread Code	Test Sheet Material	
			304 Stainless Steel	
			Installation (lbs.)	Retainer Pushout (lbs.)
PFC4	440	9100	350	
	632	10300	400	
	832	10800	450	
	032	11800	550	

METRIC	Type	Thread Code	Test Sheet Material	
			304 Stainless Steel	
			Installation (kN)	Retainer Pushout (N)
PFC4	M3	40.5	1557	
	M4	48	2002	
	M5	52.5	2447	

## PFC2™/PFS2™/PFC2P™ FASTENERS

UNIFIED	Type	Thread Code	Test Sheet Material			
			Aluminum		Cold-Rolled Steel	
			Installation (lbs.)	Retainer Pushout (lbs.)	Installation (lbs.)	Retainer Pushout (lbs.)
PFC2	440	2400	240	3000	300	
	632	2700	275	3500	350	
PFS2	832	2900	300	3800	400	
PFC2P	032	3000	400	4000	500	
	0420	3500	400	5000	600	

METRIC	Type	Thread Code	Test Sheet Material			
			Aluminum		Cold-Rolled Steel	
			Installation (kN)	Retainer Pushout (N)	Installation (kN)	Retainer Pushout (N)
PFC2	M3	10.7	1068	13.3	1334	
	M4	12.9	1334	16.9	1779	
PFS2	M5	13.3	1779	17.8	2224	
PFC2P	M6	15.6	1779	22.2	2669	

## PTL2™/PSL2™ FASTENERS

UNIFIED	Type	Test Sheet Material			
		Aluminum		Cold-Rolled Steel	
		Installation (lbs.)	Retainer Pushout (lbs.)	Installation (lbs.)	Retainer Pushout (lbs.)
PTL2	PSL2	3000	400	4000	500

METRIC	Type	Test Sheet Material			
		Aluminum		Cold-Rolled Steel	
		Installation (kN)	Retainer Pushout (N)	Installation (kN)	Retainer Pushout (N)
PTL2	PSL2	13.3	1779	17.8	2224

(1) Published installation forces are for general reference. Actual set-up and confirmation of complete installation should be made by observing proper seating of fastener as described in the installation steps. Other performance values reported are averages when all proper installation parameters and procedures are followed. Variations in mounting hole size, sheet material, and installation procedure may affect performance. Performance testing this product in your application is recommended. We will be happy to provide technical assistance and/or samples for this purpose.



Get quote >>

Angic Global Solutions

1-888-872-0690 [www.angic.com](http://www.angic.com) 183

<https://www.AngicGlobal.com> Sales@AngicGlobal.com

# PEM® CAPTIVE PANEL SCREWS

## SCBR™ FASTENERS

UNIFIED	Type	Thread Code	Rec. Tightening Torque (in. lbs.) (2)	Min. Screw Tensile (lbs.)	Test Sheet Material			
					5052-H34 Aluminum		Cold-rolled Steel	
					Installation (lbs.)	Pushout (lbs.)	Installation (lbs.)	Pushout (lbs.)
	SCBR	440	5	590	1900	130	2600	145
	SCBR	632	9	990	2000	175	3500	200
	SCBR	832	17	1460	2250	225	3825	260

METRIC	Type	Thread Code	Rec. Tightening Torque (N · m) (2)	Min. Screw Tensile (N)	Test Sheet Material			
					5052-H34 Aluminum		Cold-rolled Steel	
					Installation (kN)	Pushout (N)	Installation (kN)	Pushout (N)
	SCBR	M3	0.74	3400	8	580	12	650
	SCBR	M4	1.7	5700	10	1000	17	1150

## SCB™/SCBJ™ FASTENERS

UNIFIED	Type	Thread Code	Rec. Tightening Torque (in. lbs.) (2)	Min. Screw Tensile (lbs.)	Test Sheet Material			
					5052-H34 Aluminum		Cold-rolled Steel	
					Installation (lbs.)	Pushout (lbs.)	Installation (lbs.)	Pushout (lbs.)
	SCB / SCBJ	440	5	590	1900	130	2600	145
	SCB / SCBJ	632	9	990	2000	175	3500	200

METRIC	Type	Thread Code	Rec. Tightening Torque (N · m) (2)	Min. Screw Tensile (N)	Test Sheet Material			
					5052-H34 Aluminum		Cold-rolled Steel	
					Installation (kN)	Pushout (N)	Installation (kN)	Pushout (N)
	SCB / SCBJ	M3	0.74	3400	8	580	12	650
	SCB / SCBJ	M4	1.7	5700	10	1000	17	1150

## HSCB™ FASTENERS

UNIFIED	Type	Thread Code	Test Sheet Material			
			Aluminum		Cold-rolled Steel	
			Installation (lbs.)	Pushout (lbs.)	Installation (lbs.)	Pushout (lbs.)
	HSCB	440	1900	60	2600	80
	HSCB	632	2000	90	3500	120

METRIC	Type	Thread Code	Test Sheet Material			
			Aluminum		Cold-rolled Steel	
			Installation (kN)	Pushout (N)	Installation (kN)	Pushout (N)
	HSCB	M3	8	265	12	355

## HSR™ FASTENERS

UNIFIED	Type	Thread Code	Test Sheet Material	
			.060" FR-4 Panel	
			Installation (lbs.)	Pushout (lbs.)
	HSR	440	400	65
	HSR	632	500	80

METRIC	Type	Thread Code	Test Sheet Material	
			1.5mm FR-4 Panel	
			Installation (kN)	Pushout (N)
	HSR	M3	2.2	290

(1) Published installation forces are for general reference. Actual set-up and confirmation of complete installation should be made by observing proper seating of fastener as described in the installation steps. Other performance values reported are averages when all proper installation parameters and procedures are followed. Variations in mounting hole size, sheet material, and installation procedure may affect performance. Performance testing this product in your application is recommended. We will be happy to provide technical assistance and/or samples for this purpose.

(2) Torque values shown will produce a preload of 70% minimum tensile (125 ksi / 935 MPa) with nut factor "k" equal to .1

# PEM® CAPTIVE PANEL SCREWS

## PR10™ FASTENERS

UNIFIED	Type	Thread Code	Test Sheet Material	
			FR-4 Fiberglass	
			Installation (lbs.)	Pushout (lbs.)
PR10	440		2100	3000
	632		2100	3000
	832		2100	3600
	032		2400	4200

METRIC	Type	Thread Code	Test Sheet Material	
			FR-4 Fiberglass	
			Installation (kN)	Pushout (N)
PR10	M3		9.3	13.3
	M4		9.3	16
	M5		10.7	18.7

## N10™ FASTENERS

UNIFIED	Type	Thread Code	Test Sheet Material			
			Aluminum		Cold-Rolled Steel	
			Installation (lbs.)	Pushout (lbs.)	Installation (lbs.)	Pushout (lbs.)
N10	440		2500	95	3600	130
	632		2500	105	4000	145
	832		3000	110	5000	180
	032		3500	120	6300	200

METRIC	Type	Thread Code	Test Sheet Material			
			Aluminum		Cold-Rolled Steel	
			Installation (kN)	Pushout (N)	Installation (kN)	Pushout (N)
N10	M3		11.1	423	16	578
	M4		13.3	489	22.2	800
	M5		15.6	534	28	890

## REELFAST® SMTPLSM™ FASTENERS<sup>(2)</sup>

UNIFIED	Type and Thread Size	Min. Tensile Strength (lbs.)	Rec. Tightening Torque (in. lbs.) <sup>(3)</sup>	Test Sheet Material
				.060" P.C. Board
				Pull-off (lbs.) <sup>(4)</sup>
SMTPLSM-440		556	4.4	100
SMTPLSM-632		724	7.0	105

METRIC	Type and Thread Size	Min. Tensile Strength (N)	Rec. Tightening Torque (N-m) <sup>(3)</sup>	Test Sheet Material
				1.5 mm P.C. Board
				Pull-off (N) <sup>(4)</sup>
SMTPLSM-M3		2900	0.61	445
SMTPLSM-M3.5		3269	0.8	465

### TESTING CONDITIONS FOR SMTPLSM FASTENERS AND SMTPR RETAINER

Oven	Quad ZCR convection oven
High Temp	473 °F / 245 °C
Spokes	2 Spoke Pattern
Board Finish	62% Sn, 38% Pb
Screen Printer	Ragin Manual Printer
Vias	None
Paste	Amtech NC559LF Sn96.5/3.0Ag/0.5Cu (SAC305) (SMTPR) Alpha CVP-390 Sn96.5/3.0Ag/0.5Cu (SAC305) (SMTPLSM)
Stencil	.0067" / 0.17 mm thick (SMTPR) .005" / 0.13 mm thick (SMTPLSM)

## REELFAST® SMTPR™ RETAINER<sup>(2)</sup>

Part Number	Test Sheet Material	
	.062" Single Layer RF-4	
	Pushout (lbs.)	Pushout (N)
SMTPR-6-1ET	161.4	718

## PFK™ FASTENERS

UNIFIED	Type	Thread Code	Test Sheet Material	
			FR-4 Fiberglass	
			Installation (lbs.)	Pushout (lbs.)
PFK	440		250	55
	632		400	60

METRIC	Type	Thread Code	Test Sheet Material	
			FR-4 Fiberglass	
			Installation (kN)	Pushout (N)
PFK		M3	1.1	245

(1) Published installation forces are for general reference. Actual set-up and confirmation of complete installation should be made by observing proper seating of fastener as described in the installation steps. Other performance values reported are averages when all proper installation parameters and procedures are followed. Variations in mounting hole size, sheet material, and installation procedure may affect performance. Performance testing this product in your application is recommended. We will be happy to provide technical assistance and/or samples for this purpose.

(2) With lead-free paste. Average values of 30 test points. The data presented here is for general comparison purposes only. Actual performance is dependent upon application variables. We will be happy to provide samples for you to install. If required, we can also test your installed hardware and provide you with the performance data specific to your application.

(3) Torque values shown will produce a preload of 70% minimum tensile with a nut factor "k" equal to .1.

(4) Failure occurred at the solder joint.



Get quote >>

Angic Global Solutions

1-888-872-0690 [www.AngicGlobal.com](http://www.AngicGlobal.com) 185

<https://www.AngicGlobal.com> Sales@AngicGlobal.com

## CAPTIVE PANEL SCREW CAPABILITIES

### MOST COMMONLY USED AND RECOMMENDED CAPTIVE MATING HARDWARE FOR USE WITH CAPTIVE PANEL SCREWS

#### SELF-CLINCHING NUTS MATED WITH CAPTIVE PANEL SCREW

(See PEM® [Bulletin CL](#))

- S/CLS/SS/CLSS provide load-bearing threads in thin sheets with high pushout and torque-out resistance.
- SP nuts provide load-bearing threads in stainless steel sheets with a hardness of HRB 90 (Rockwell "B" scale) / HB 192 (Hardness Brinell) or less.
- CLA aluminum nuts are recommended for aluminum sheets with a hardness of HRB 50 (Rockwell "B" scale) / HB 89 (Hardness Brinell) or less.
- SMPS nuts are for installation into ultra-thin sheets and can be mounted closer to the edge of a sheet than other self-clinching nuts.
- SL nuts have a unique TRI-DENT® locking feature which meets demanding locking performance requirements.



#### AS/AC/A4 FLOATING NUTS MATED WITH CAPTIVE PANEL SCREW

(See PEM® [Bulletin ALA](#))

- AS (carbon steel) and AC (300 series stainless steel) floating nuts install into sheets with hardness up to HRB 70 / HB 125 on the Rockwell "B" scale.
- A4 (400 series stainless steel) floating nuts install into sheets with hardness up to HRB 88 / HB 183 on the Rockwell "B" scale.
- Thread locking versions also available.



#### B/BS BLIND NUTS MATED WITH CAPTIVE PANEL SCREW

(See PEM® [Bulletin B](#))

- B/BS nuts are used in applications requiring closed thread ends.
- Provides barrier to protect threads against foreign matter.
- Protects internal components from intrusion of screws.



#### F FLUSH NUTS MATED WITH CAPTIVE PANEL SCREW

(See PEM® [Bulletin F](#))

- Designed to be completely flush in sheets as thin as .060"/1.5mm.
- Ideal for applications where a thin sheet requires load-bearing threads but still must remain smooth, with no protrusions on either surface.
- The hexagonal head ensures high axial and torsional strength.
- F nuts can be ordered to conform to US NASM45938/4 specifications.



#### PC BOARD NUTS MATED WITH CAPTIVE PANEL SCREW

(See PEM® [Bulletin K](#))

- KF2/KFS2 broaching nuts utilize specially formed axially grooves that can be mounted into a hole to provide a permanent, strong, threaded attachment point in PC boards.
- SMTSO surface mount nuts also available.



For the best mating hardware for your application please contact our [Tech Support](#) line or your local representative.

# PEM® CAPTIVE PANEL SCREWS

## PEM® TRADEMARKS

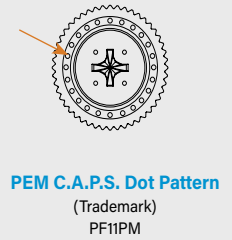
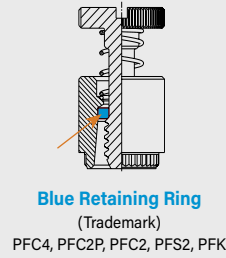
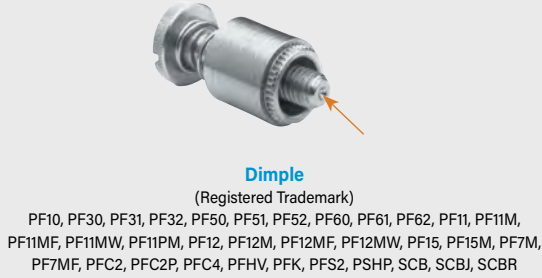
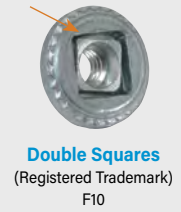

To be sure that you are getting genuine PEM® brand fasteners, look for the unique PEM® product markings and identifiers.

These panel fastener styles are protected by U.S. patents:



Fastener drawings and models are available at [www.pemnet.com](http://www.pemnet.com)



Get quote »

Angic Global Solutions

1-888-872-0690 [www.pemnet.com](http://www.pemnet.com) 187

<https://www.AngicGlobal.com> Sales@AngicGlobal.com



PEM® R'ANGLE® fasteners provide strong right angle attachment points in thin sheets.

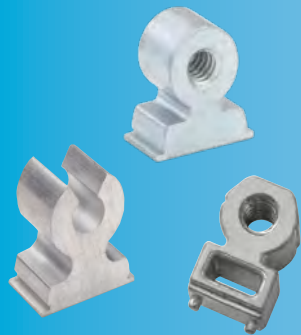

**RA™**

**RIGHT ANGLE  
FASTENERS**

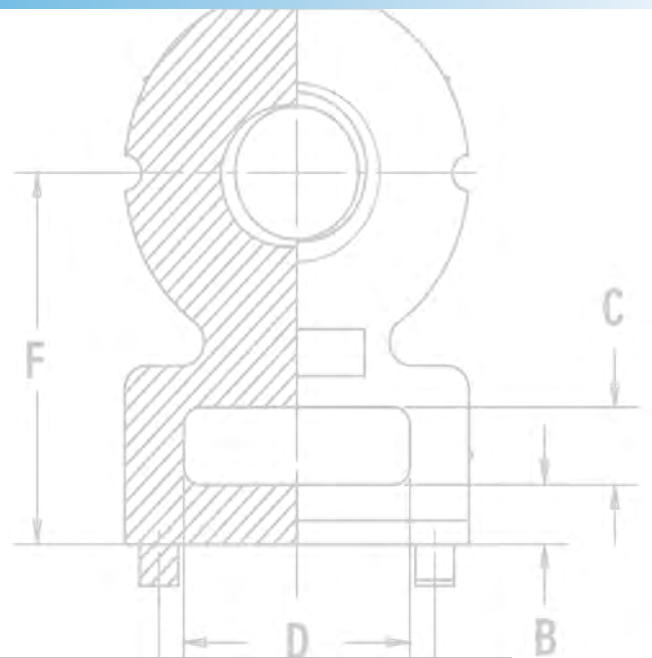

Get quote »

Angic Global Solutions

1-888-872-0690

<https://www.AngicGlobal.com> [Sales@AngicGlobal.com](mailto:Sales@AngicGlobal.com)

# RIGHT ANGLE FASTENERS



PEM® R'ANGLE® fasteners provide strong right angle attachment points in sheet metal or PC Boards. **RAA™** and **RAS™** fasteners for metal are simply pressed into a rectangular mounting hole of the proper size. **SMTRA™** fasteners are installed onto PC Boards using standard surface mount techniques. The holding power of the fastener is unaffected by the repeated tightening and loosening of the screw.

PEM® R'ANGLE® fasteners are cost-effective replacements for:

- Bent edge tabs
- Bent center tabs
- Bent flanges
- Angle brackets
- Tack welds
- Loose hardware

PEM® R'ANGLE® fasteners provide many advantages over bent tabs and flanges, including:

- More predictable designs
- Tighter design control
- Reduction of loose hardware
- Unmarred panel surfaces
- Material savings
- Improved shielding characteristics
- Fewer assembly steps

<p><b>RAS™</b> fasteners for sheet metal is a threaded right angle fastener that accepts standard unified or metric screws - <b>PAGE 190</b></p> 	<p><b>SMTRA™</b> right angle threaded fasteners are installed on to PC Boards using standard surface mount techniques. They accept standard unified or metric screws - <b>PAGE 192</b></p> 
<p><b>RAA™</b> right angle fasteners for sheet metal can accept thread forming or self-tapping screws - <b>PAGE 191</b></p> 	<p><b>Material and finish specifications - PAGE 193</b></p> <p><b>Installation - PAGES 191-194</b></p> <p><b>Performance data - PAGES 194-195</b></p>

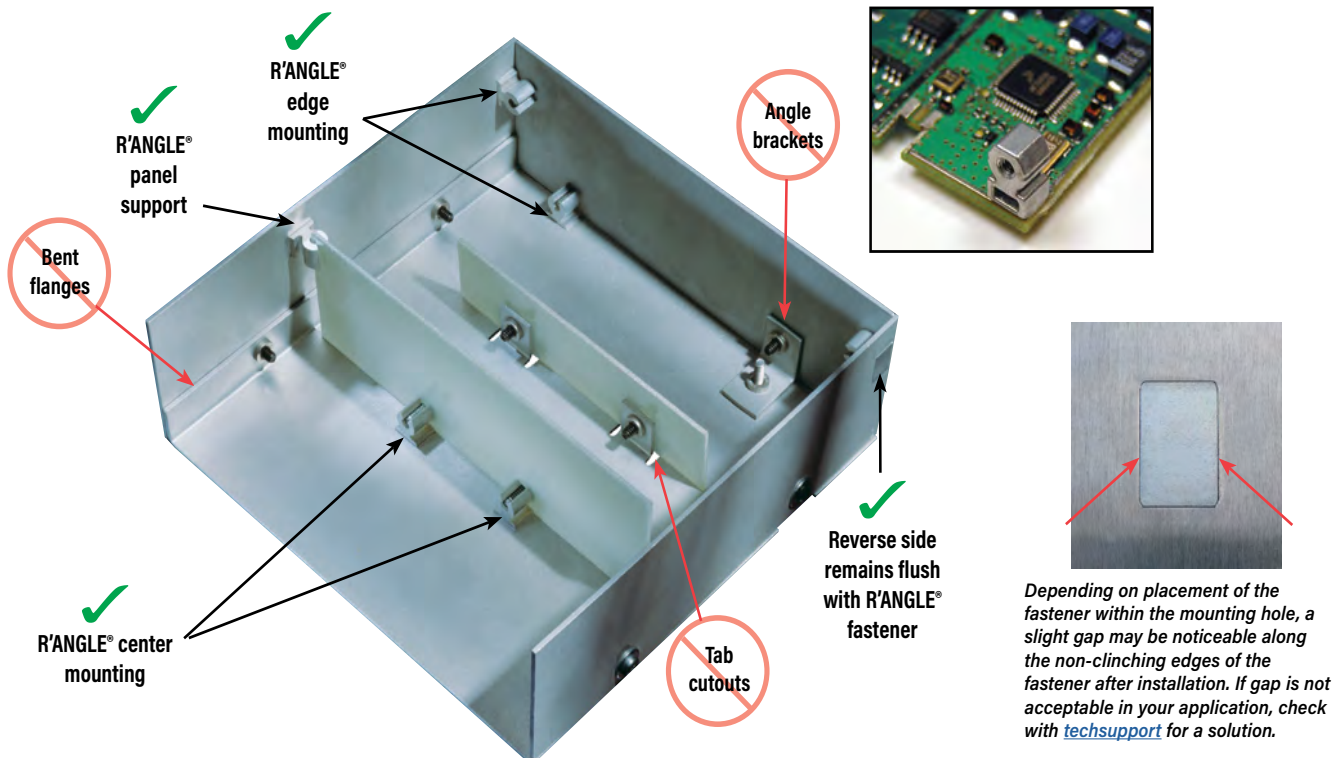

# RIGHT ANGLE FASTENERS

## PEM® RAS™ THREADED RIGHT ANGLE FASTENER

For use with standard metric or unified screws

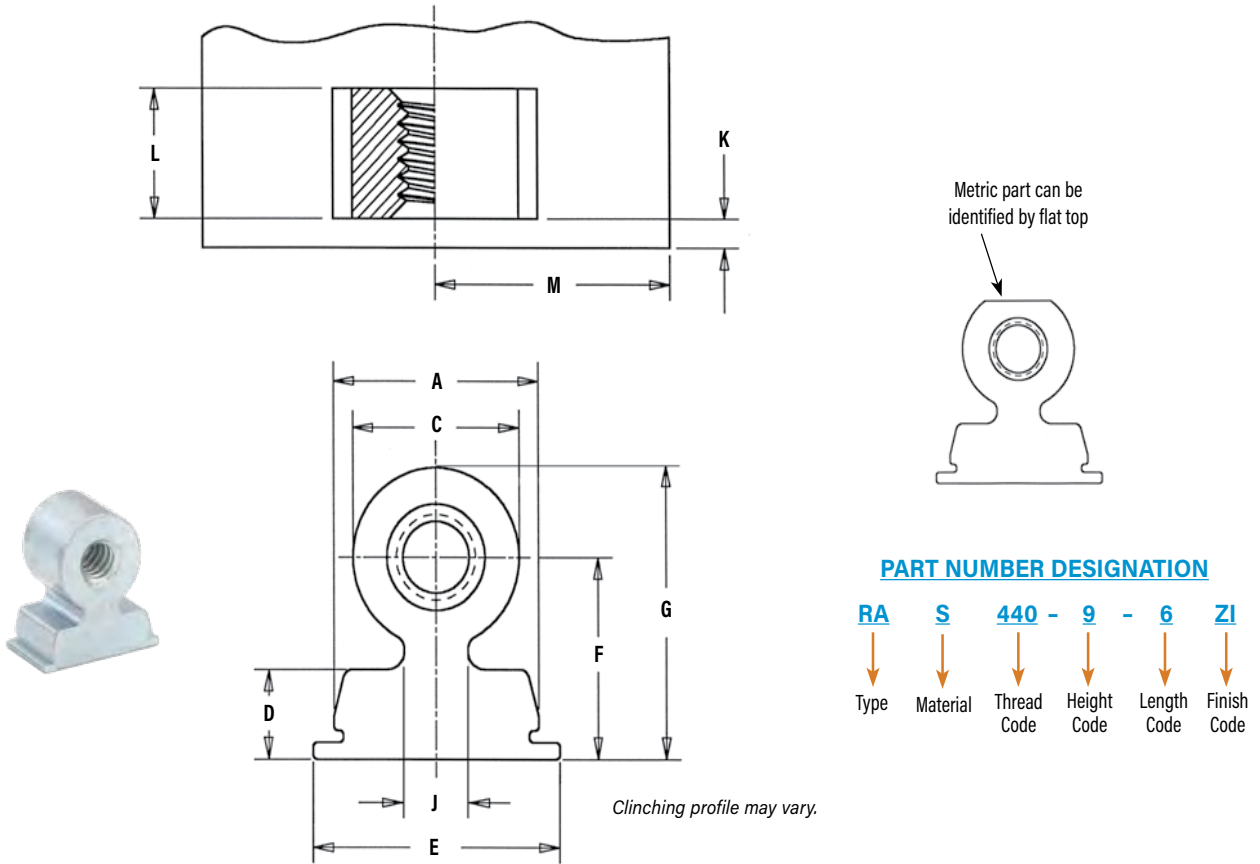

All dimensions are in inches.

UNIFIED	Thread Size	Type	Fastener Material	Thread Code	Height Code	Length Code	Length L ±.003	Min. Sheet Thickness	Hole Size In Sheet +.002 -.001	A ±.003	C Nom.	D Nom.	E ±.006	Height F ±.006	G Nom.	J Nom.	Min. Part Face to Edge K	Min. Dist. Hole $\varnothing$ To Edge M
	.112-40 (#4-40)	RA	S	440	9	4	.121	.040	.312 x .125	.308	.250	.125	.370	.281	.406	.096	.040	
6						.183	.35											
8						.246	.43											
.138-32 (#6-32)	RA	S	632	10	4	.121	.040	.375 x .125	.371	.300	.125	.433	.312	.462	.141	.040		.35
					8	.246		.50										
					10	.308		.55										
.164-32 (#8-32)	RA	S	832	12	6	.183	.040	.406 x .187	.402	.350	.125	.464	.375	.550	.157	.040		.40
					9	.277		.58										
					12	.371		.65										

All dimensions are in millimeters.

METRIC	Thread Size x Pitch	Type	Fastener Material	Thread Code	Height Code	Length Code	Length L ±0.08	Min. Sheet Thickness	Hole Size In Sheet +0.05 -0.03	A ±0.08	C Nom.	D Nom.	E ±0.15	Height F ±0.15	G Nom.	J Nom.	Min. Part Face to Edge K	Min. Dist. Hole $\varnothing$ To Edge M
	M3 x 0.5	RA	S	M3	7	3	2.89	1	8 x 3	7.89	6.35	3.18	9.47	7	9.78	2.87	1.02	
4						3.89	9.1											
6						5.89	10.7											
M4 x 0.7	RA	S	M4	9	4	3.89	1	10 x 4	9.89	8.89	3.18	11.48	9	13.21	4.06	1.02		10
					7	6.89		14.7										
					9	8.89		16.3										



Get quote >>

Angic Global Solutions

1-888-872-0690 [www.angic.com](http://www.angic.com) 190

<https://www.AngicGlobal.com> Sales@AngicGlobal.com

# RIGHT ANGLE FASTENERS

## RAA™ RIGHT ANGLE FASTENER

For use with thread forming screws

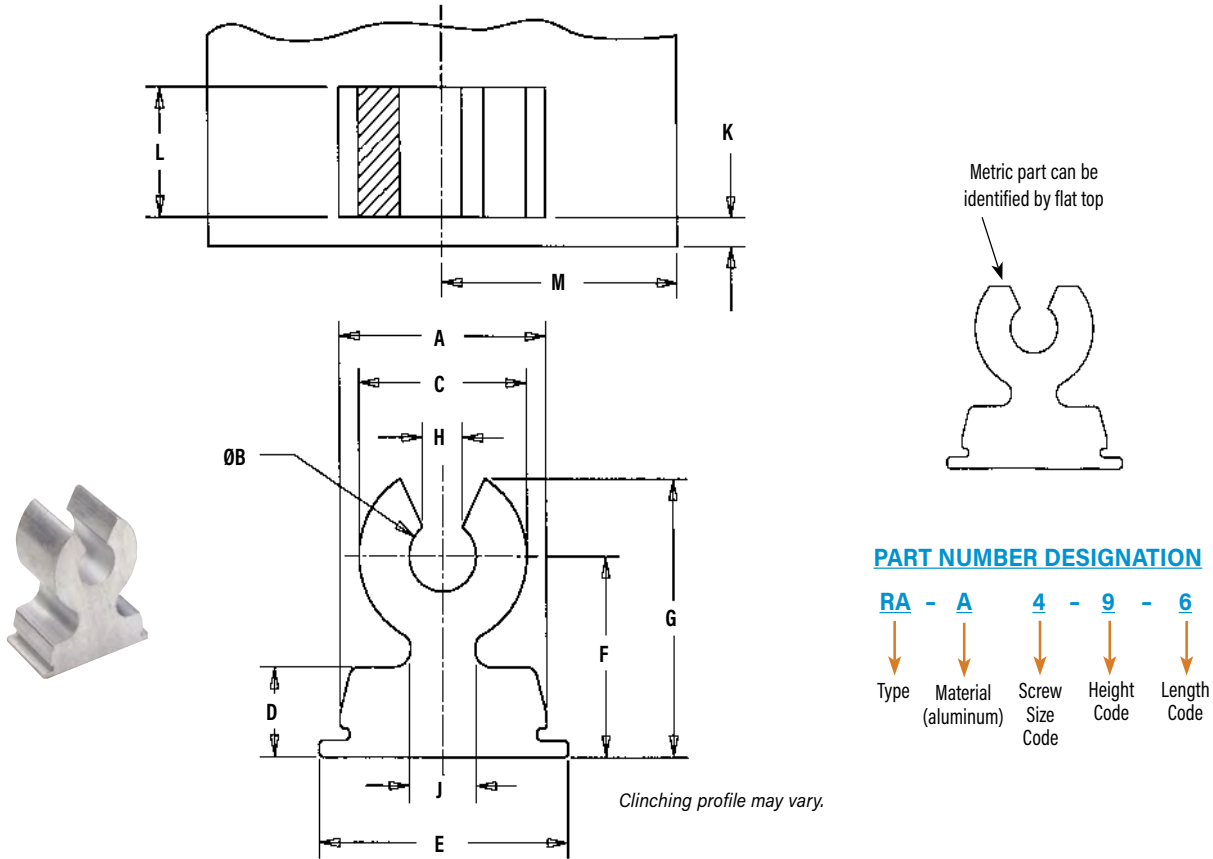

All dimensions are in inches.

UNIFIED	Thread Form Screw Size	Type	Fastener Material	Screw Size Code	Height Code	Length Code	Length L ±.003	Min. Sheet Thickness	Hole Size In Sheet +.002 - .001	A ±.003	ØB ±.004	C Nom.	D Nom.	E ±.006	Height F ±.006	G Nom.	H ±.007	J Nom.	Min. Part Face to Edge K	Min. Dist. Hole To Edge M
	#4-40	RA	A	4	9	6	.183	.040	.312 x .187	.308	.100	.250	.125	.368	.281	.389	.054	.096	.040	.35
8						.246	.312 x .250		.36											
#6-32	RA	A	6	10	8	.246	.040	.375 x .250	.371	.123	.300	.125	.431	.312	.442	.066	.141	.040	.50	
					10	.308		.375 x .312											.55	
#8-32	RA	A	8	12	9	.277	.040	.406 x .281	.402	.145	.350	.125	.462	.375	.525	.078	.157	.040	.58	
					12	.371		.406 x .375											.65	

All dimensions are in millimeters.

METRIC	Thread Form Screw Size	Type	Fastener Material	Screw Size Code	Height Code	Length Code	Length L ±0.08	Min. Sheet Thickness	Hole Size In Sheet +0.05 - 0.03	A ±0.08	ØB ±0.1	C Nom.	D Nom.	E ±0.15	Height F ±0.15	G Nom.	H ±0.18	J Nom.	Min. Part Face to Edge K	Min. Dist. Hole To Edge M
	M3 x 0.5	RA	A	M3	7	4	3.89	1	8 x 4	7.89	2.77	6.35	3.18	9.42	7	9.27	1.5	2.87	1.02	9.1
6						5.89	8 x 6		10.7											
M4 x 0.7	RA	A	M4	9	7	6.89	1	10 x 7	9.89	3.68	8.89	3.18	11.43	9	12.19	1.97	4.06	1.02	14.7	
					9	8.89		10 x 9											16.3	

# RIGHT ANGLE FASTENERS

## SMTRA™ ReelFast® RIGHT ANGLE FASTENERS

Surface mounted and threaded to accept standard unified or metric screw

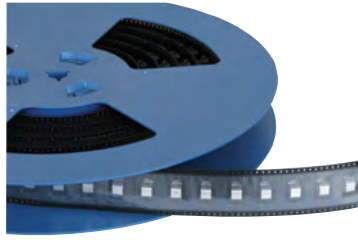

Patented

### PART NUMBER DESIGNATION

SMTRA - 256 - 8 - 6 ET

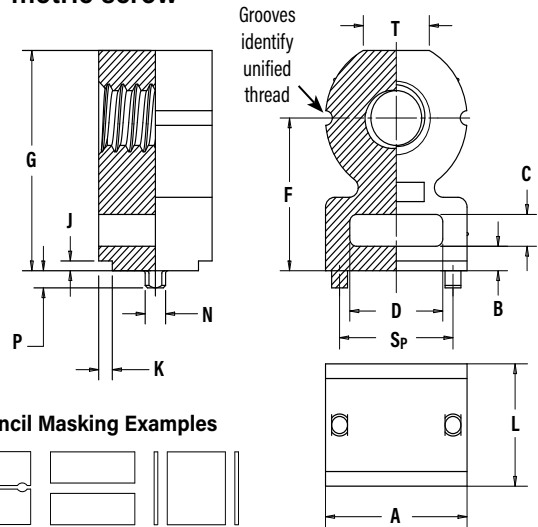
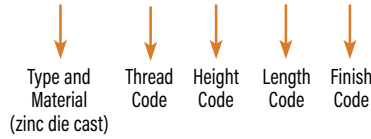

### Stencil Masking Examples



All dimensions are in inches.

UNIFIED	Thread Size	Type	Thread Code	Height Code	Length Code	Length L ±.005	Min. Sheet Thickness	Hole Size In Sheet +0.003 -0.000	A ±.006	B ±.006	C ±.006	D ±.006	Height F ±.006	G ±.006	J Nom.	K Nom.	N Max.	P Max.	Sp ±.003	T Nom.
	.086-56 (#2-56)	SMTRA	256	8	6	.188	.040	.053	.218	.040	.060	.140	.250	.345	.020	.030	.048	.040	.157	.105
	.112-40 (#4-40)	SMTRA	440	9	6	.188	.040	.053	.250	.050	.065	.160	.281	.390	.020	.030	.048	.040	.188	.125
	.138-32 (#6-32)	SMTRA	632	10	8	.250	.040	.053	.312	.050	.065	.205	.312	.450	.020	.030	.048	.040	.250	.145
	.164-32 (#8-32)	SMTRA	832	12	9	.281	.040	.053	.375	.050	.075	.250	.375	.535	.020	.030	.048	.040	.312	.195

All dimensions are in millimeters.

METRIC	Thread Size x Pitch	Type	Thread Code	Height Code	Length Code	Length L ±0.13	Min. Sheet Thickness	Hole Size In Sheet +0.08	A ±0.15	B ±0.15	C ±0.15	D ±0.15	Height F ±0.15	G ±0.15	J Nom.	K Nom.	N Max.	P Max.	Sp ±0.08	T Nom.
	M2 x 0.4	SMTRA	M2	6	5	5	1	1.35	5.5	1	1.5	3.5	6	8.4	0.5	0.75	1.22	1	4	2.65
	M2.5 x 0.45	SMTRA	M25	6	5	5	1	1.35	5.5	1	1.5	3.5	6	8.4	0.5	0.75	1.22	1	4	2.65
	M3 x 0.5	SMTRA	M3	7	5	5	1	1.35	6.35	1.25	1.65	4	7	9.75	0.5	0.75	1.22	1	4.75	3.2
	M4 x 0.7	SMTRA	M4	9	7	7	1	1.35	9.53	1.25	1.65	6.35	9	13.1	0.5	0.75	1.22	1	7.9	4.8

UNIFIED	Thread Code	Pad Width P <sub>A</sub> Min.	Pad Length P <sub>L</sub> Min.	Hole Spacing S <sub>H</sub> ±.002	Hole Size In Sheet +0.003 -0.000
	256	.262	.171	.157	.053
	440	.294	.171	.188	.053
	632	.356	.233	.250	.053
	832	.419	.264	.312	.053

METRIC	Thread Code	Pad Width P <sub>A</sub> Min.	Pad Length P <sub>L</sub> Min.	Hole Spacing S <sub>H</sub> ±0.05	Hole Size In Sheet +0.08
	M2	6.62	4.57	4	1.35
	M25	6.62	4.57	4	1.35
	M3	7.47	4.57	4.75	1.35
	M4	10.65	6.57	7.9	1.35

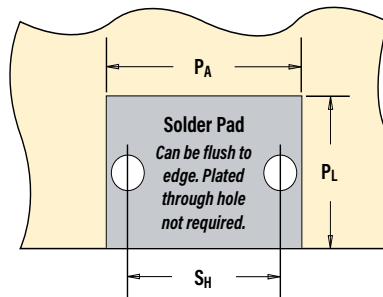

If desired, space can be used for fast cable tie mounting.

Part Number	Parts Per Reel	Pitch (mm)	Tape Width (mm)
SMTRA256-8-6	375	16	24
SMTRA440-9-6	300	16	24
SMTRA632-10-8	200	20	32
SMTRA832-12-9	200	20	32
SMTRAM2-6-5	375	16	24
SMTRAM25-6-5	375	16	24
SMTRAM3-7-5	300	16	24
SMTRAM4-9-7	200	20	32



Get quote >>

Angic Global Solutions

1-888-872-0690 [www.angic.com](http://www.angic.com) 192

<https://www.AngicGlobal.com> Sales@AngicGlobal.com

# RIGHT ANGLE FASTENERS

## MATERIAL AND FINISH SPECIFICATIONS

Type	Threads	Fastener Materials			Standard Finishes <sup>(1)</sup>			For Use In Sheet Hardness: <sup>(2)</sup>		
	Internal, ASME B1.1, 2B ASME B1.13M, 6H	Aluminum	Steel	Zinc Die Cast	Zinc Plated per ASTM B633, SCl (5µm), Type III, Colorless	Natural	Electro-plated Tin ASTM B 545, Class A with Clear Preservative Coating, Annealed	HRB 45 / HB 84 or Less	HRB 60 / HB 107 or Less	PC Board
RAS	▪		▪		▪				▪	
RAA		▪				▪		▪		
SMTRA	▪			▪			▪			▪
Part Number Codes for Finishes					ZI	None	ET <sup>(3)</sup>			

- (1) See PEM® Technical Support section of our website for related plating standards and specifications.  
 (2) HRB - Hardness Rockwell "B" Scale. HB - Hardness Brinell.  
 (3) Optimal solderability life noted on packaging.

## INSTALLATION

### RAS™ and RAA™ Fasteners

1. Prepare a properly sized rectangular mounting hole in the sheet. Do not perform any secondary operations such as deburring.
2. Place the fastener through the mounting hole (preferably the punch side) and into the anvil as shown in the drawing to the right.
3. With the installation punch and anvil surfaces parallel, apply a squeezing force until the bottom of the fastener becomes flush with the sheet.

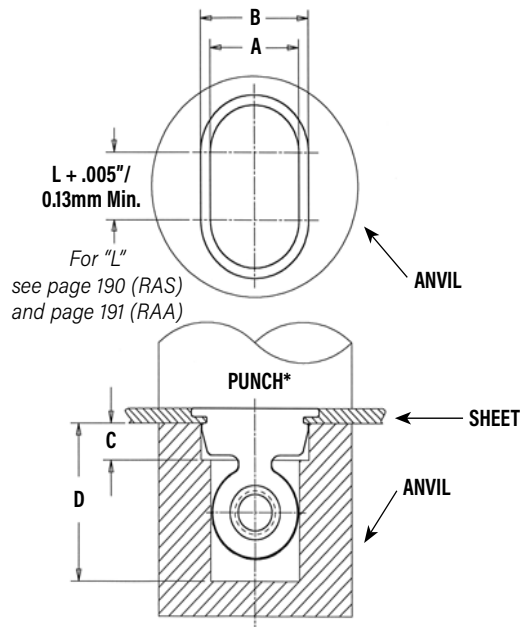

\* NOTE: The punch must be large enough to cover the entire base of the fastener to ensure proper installation.

Installation tooling is available from PennEngineering.

### PEMSERTER® Installation Tooling

UNIFIED	Screw or Thread Size Code	Anvil Dimensions (in.)				Anvil Part Number	Punch Part Number
		A ±.001	B ±.001	C ±.005	D Min.		
	4 / 440	.257	.313	.100	.425	8002711	8003076
	6 / 632	.307	.376	.100	.500	8002712	
	8 / 832	.357	.407	.100	.575	8003642	

METRIC	Screw or Thread Size Code	Anvil Dimensions (mm)				Anvil Part Number	Punch Part Number
		A ±0.03	B ±0.03	C ±0.1	D Min.		
	M3	6.53	8.02	2.54	10.8	8002713	8003076
	M4	9.07	10.03	2.54	12.7	8002714	

### MOUNTING HOLE EXAMPLES

The mounting hole is defined by two dimensions. The two thick lines shown must be straight for the entire length defined by "Side 2" and must be separated by the distance shown as "Side 1" (Side 1 and Side 2 are the two dimensions given for the mounting hole on pages 3 and 4). The illustration shows three examples (#1, #2, and #3) of how it can be achieved. Example #4 in the lower right side will not work.

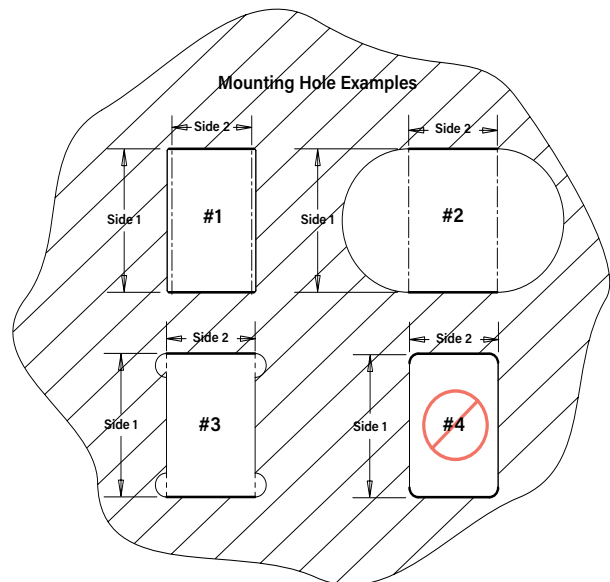

#### INSTALLATION NOTES

- For best results we recommend using a HAEGER® or PEMSERTER® machine for installation of PEM® self-clinching fasteners. Please check our website for more information.
- Visit the Animation Library on our website to view the installation process [for this product](#).

# RIGHT ANGLE FASTENERS

## SMTRA™ SURFACE MOUNT FASTENERS

Flat top for vacuum pick up.

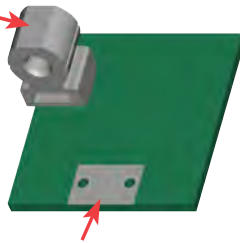

Solder paste applied to pad on PCB.

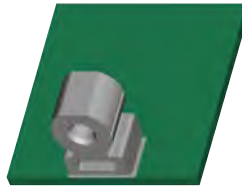

Solder fastener in place using standard surface mount techniques.

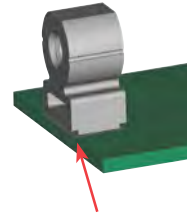

Undercut to accept solder fillet and permit flush to edge installation.

## PERFORMANCE DATA<sup>(1)</sup>

### RAS™ THREADED FASTENERS

UNIFIED	Thread Code	Height Code	Length Code	Test Sheet Material									
				5052-H34 Aluminum					Cold-rolled Steel				
				Max. Rec. Tightening Torque (in. lbs.)	Installation (lbs.)	Pushout (lbs.) (2)	Side Load (lbs.) (3)	Pull Thru (lbs.)	Max. Rec. Tightening Torque (in. lbs.)	Installation (lbs.)	Pushout (lbs.) (2)	Side Load (lbs.) (3)	Pull Thru (lbs.)
440	9	4	13	1800	100	7	80	16	2400	180	9	80	
		6	17	1800	145	8	80	17	2400	260	9	80	
		8	17	2100	180	13	80	17	3000	315	15	80	
632	10	4	20	2000	100	7	85	20	2500	190	9	85	
		8	21	2500	190	12	85	26	3200	335	16	85	
		10	21	2800	230	16	85	26	4000	385	20	85	
832	12	6	20	2400	140	15	100	27	3200	260	11	100	
		9	23	3300	195	16	100	29	4200	345	20	100	
		12	30	3500	260	20	100	35	4700	420	27	100	

METRIC	Thread Code	Height Code	Length Code	Test Sheet Material									
				5052-H34 Aluminum					Cold-rolled Steel				
				Max. Rec. Tightening Torque (N-m)	Installation (kN)	Pushout (N) (2)	Side Load (N) (3)	Pull Thru (N)	Max. Rec. Tightening Torque (N-m)	Installation (kN)	Pushout (N) (2)	Side Load (N) (3)	Pull Thru (N)
M3	7	3	1.47	8	423	36	356	2.26	10.7	778	40	356	
		4	1.92	8	534	36	356	2.71	10.7	1001	40	356	
		6	2.15	9.3	756	58	356	2.71	13.3	1312	67	356	
M4	9	4	2.15	8.9	556	53	423	3.28	11.6	956	44	423	
		7	2.6	13.3	890	76	423	4.07	16	1512	80	423	
		9	2.83	13.3	1112	93	423	4.52	18.7	1846	116	423	

### RAA™ FASTENERS

UNIFIED	Screw Size Code	Height Code	Length Code	Thread Forming Torque (in. lbs.)	Max. Rec. Tightening Torque (in. lbs.)	Test Sheet Material	Installation (lbs.)	Pushout (lbs.) (2)	Side Load (lbs.) (3)	Pull Thru (lbs.)
			8	4	10	Aluminum	1800	180	13	80
	6	10	8	5.5	11	5052-H34 Aluminum	2500	175	12	85
			10	5.5	17	Aluminum	2500	235	16	85
	8	12	9	6.5	18	5052-H34 Aluminum	3100	205	13	105
			12	8.0	20	Aluminum	3100	255	21	105

METRIC	Screw Size Code	Height Code	Length Code	Thread Forming Torque (N-m)	Max. Rec. Tightening Torque (N-m)	Test Sheet Material	Installation (kN)	Pushout (N) (2)	Side Load (N) (3)	Pull Thru (N)
			6	.23	1.02	Aluminum	7.1	756	44	356
	M4	9	7	.56	2.26	5052-H34 Aluminum	13.3	890	76	423
			9	.56	2.83	Aluminum	13.3	1045	107	423

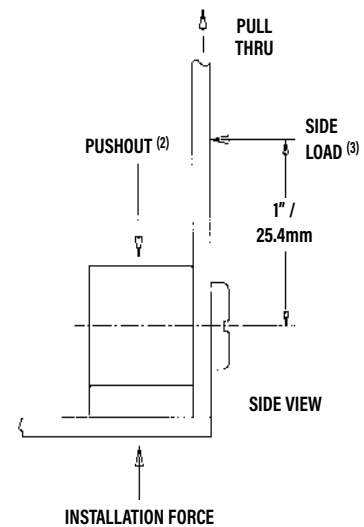

(1) Published installation forces are for general reference. Actual set-up and confirmation of complete installation should be made by observing proper seating of fastener as described in the installation steps. Other performance values reported are averages when all proper installation parameters and procedures are followed. Variations in mounting hole size, sheet material, and installation procedure may affect performance. Performance testing this product in your application is recommended. We will be happy to provide technical assistance and/or samples for this purpose.

(2) Pushout test is conducted without side panel attached to R'ANGLE® fastener.

(3) 1" / 25.4mm from screw centerline.



Get quote >>

Angic Global Solutions

1-888-872-0690 [www.angic.com](http://www.angic.com) 194

<https://www.AngicGlobal.com> Sales@AngicGlobal.com

# RIGHT ANGLE FASTENERS

## PERFORMANCE DATA

### SMTRA™ R'ANGLE® FASTENERS WITH ET FINISH<sup>(1)(2)</sup>

UNIFIED	Part Number	Pullout (lbs.)	Side Load (lbs.)
	SMTRA256-8-6	51.7	71
	SMTRA440-9-6	89.5	10.8
	SMTRA632-10-8	110.3	8.4
	SMTRA832-12-9	137.2	21.2

METRIC	Part Number	Pullout (N)	Side Load (N)
	SMTRAM2-6-5	418.2	56.8
	SMTRAM25-6-5	216.5	36.9
	SMTRAM3-7-5	257.6	41.3
	SMTRAM4-9-7	369.3	73.3

#### TESTING CONDITIONS

<b>Oven</b>	Quad ZCR convection oven with 4 zones
<b>Vias</b>	None
<b>High Temp</b>	518 °F / 270 °C
<b>Board Finish</b>	62% Sn, 38% Pb
<b>Paste</b>	Amtech NC559LF Sn96.5/3.0Ag/0.5Cu (SAC305) Lead-free
<b>Board</b>	.062" thick, Single Layer FR-4
<b>Stencil</b>	.0067" / 0.17 mm thick
<b>Screen Printer</b>	Ragin Manual Printer

- (1) With lead-free paste. Average values of 30 test points. The data presented here is for general comparison purposes only. Actual performance is dependent upon application variables. We will be happy to provide samples for you to install. If required, we can also test your installed hardware and provide you with the performance data specific to your application.
- (2) Further testing details can be found in the literature section on our website.

PEM® "Circle on Pedestal"  
(Registered Trademark)

Fastener drawings and models are available at [www.pemnet.com](http://www.pemnet.com)

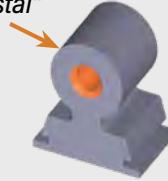



Allows permanent joining in metal to metal and metal to PCB/plastic panels.

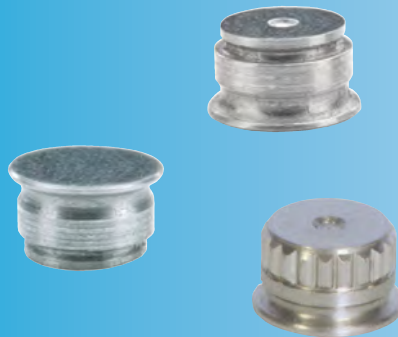

**SF™**

**SPOTFAST®  
FASTENERS**

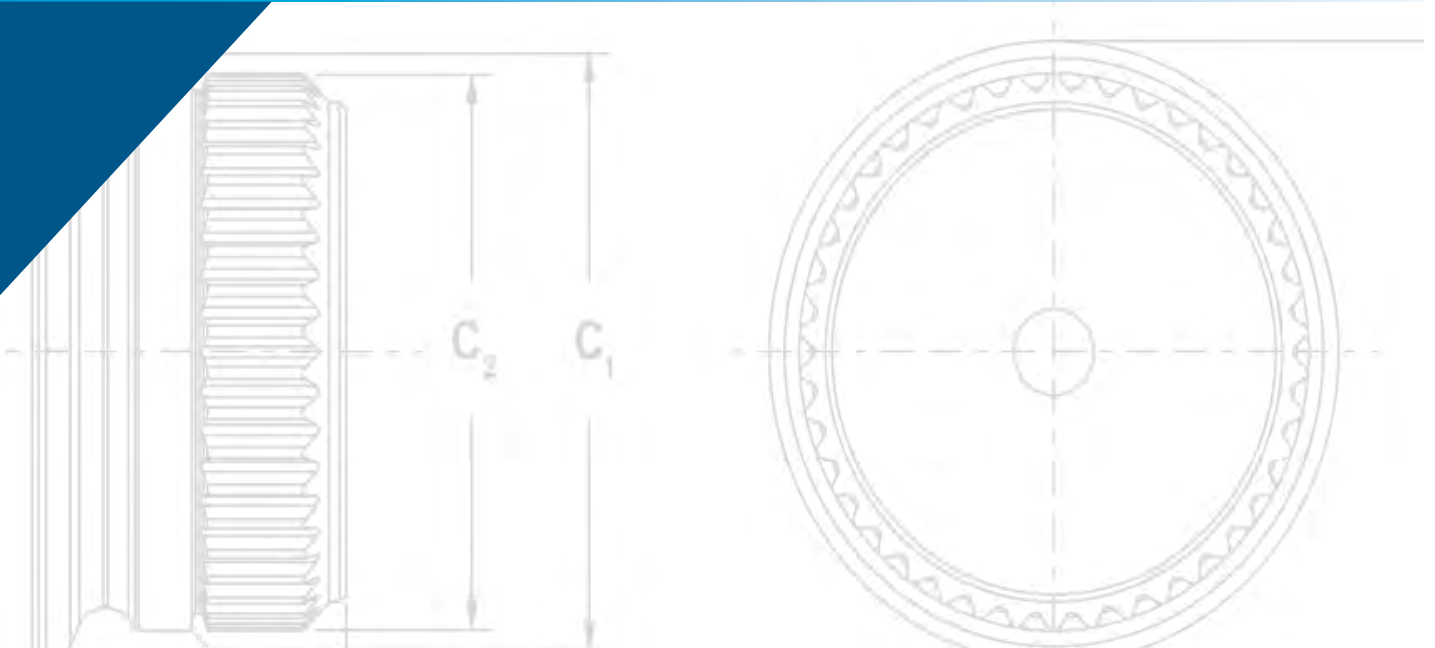

Get quote >>

Angic Global Solutions

1-888-872-0690





<https://www.AngicGlobal.com> [Sales@AngicGlobal.com](mailto:Sales@AngicGlobal.com)

# SPOTFAST® FASTENERS

## Allows permanent joining in metal to metal and metal to PCB/plastic panels

- Alternative to riveting and spot welding.
- No special installation equipment required.
- Flush or sub-flush on both sides.
- Minimal space requirements.
- No countersinking or other hole treatment required.
- Can be installed blind into bottom (panel 2) sheet.
- Can be concealed with paints and powder coatings.
- RoHS compliant.

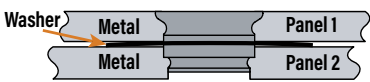
Unlike rivets that “bulb” during installation, the ultimately flush profile of SpotFast® fasteners allows for unobtrusive attachment requiring minimal space. A smooth surface is retained for finishing and fasteners can be concealed easily with paints or powder coatings.

<p><b>SF™</b> fasteners create a permanent, flush joining of two sheets. Squeezing the fastener into place causes a cold-flow of panel material into the fastener’s two separate clinch profiles. The SF fastener is <b>designed for joining metal to metal</b>. They install smooth with the top sheet, and flush or sub-flush with the bottom sheet. Fasteners can attach two metal sheets too difficult to weld; fasten sheets of unequal thicknesses; join dissimilar metals unable to be welded; and even attach ultra-thin metal sections.</p>	
<p><b>SFP™</b> fasteners offer the same benefits as the SF fastener but are made from precipitation hardened stainless steel <b>for installation into stainless steel sheets</b>.</p>	
<p><b>SFW™</b> fasteners offer the same benefits as the SF fastener but are specifically <b>designed to allow pivoting (hinging) of two sheets of metal</b>. A wave washer provides the consistent torsion to allow repeatable rotation.</p>	
<p><b>SFK™</b> fasteners are designed for <b>flush joining of metal to PCB/plastic panels</b></p>	



### PART NUMBER DESIGNATION

<b>SF</b>	-	<b>3</b>	-	<b>1.0</b>	-	<b>ZI</b>
<b>SFP</b>	-	<b>3</b>	-	<b>1.0</b>	-	
<b>SFW</b>	-	<b>3</b>	-	<b>1.0</b>	-	<b>LZ</b>
<b>SFK</b>	-	<b>3</b>	-	<b>1.0</b>	-	<b>ZI</b>
	↓	↓	↓	↓	↓	
Type		Size (Panel 1 Mounting Hole Code)		Thickness Code		Finish

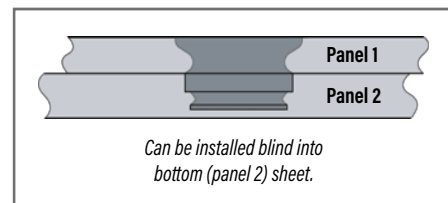

## SPOTFAST® FASTENER SELECTOR GUIDE

Type	Primary Use				
	Joining two panels of similar or dissimilar metals	Joining two panels when one or more is stainless steel	Joining a metal panel to a PCB or plastic panel	Single point hinging applications	Offers highest corrosion resistance in product family
SF	▪			▪ (1)	
SFP	▪ (1)	▪		▪ (1)	▪
SFW	▪ (1)			▪	
SFK	▪ (1)		▪	▪ (1)	

(1) Not primary use.

### METAL TO METAL

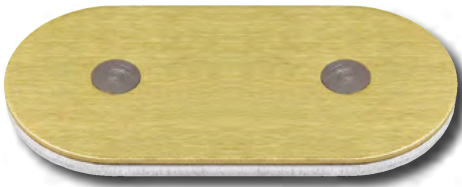

SF™ fastener installed into unequal thickness sheets. Fastener is smooth with top of panel 1.



SF™ fastener installed sub-flush with panel 2. Fastener will be flush at minimum sheet thickness.

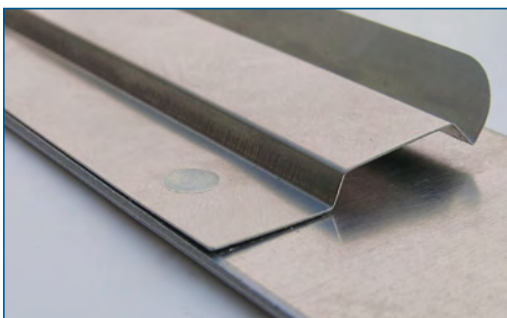

Sheets as thin as .005" / 0.13 mm may be attached to thicker sheets using a PEM® SpotFast® fastener. The thin sheet must be panel 1 and the "L" dimension must be equal to or less than the combined panel thicknesses. Consult our Applications Engineering department for more information.

### HINGING APPLICATIONS



SFW™ fastener offers flush-mounted, smooth pivot point.

### METAL TO PCB/PLASTIC

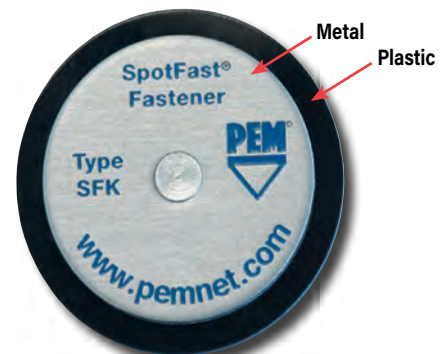

SFK™ fastener joining metal to plastic.

# SPOTFAST® FASTENERS

## SF™ AND SFP™ FASTENERS FOR PERMANENT JOINING OF TWO METAL SHEETS

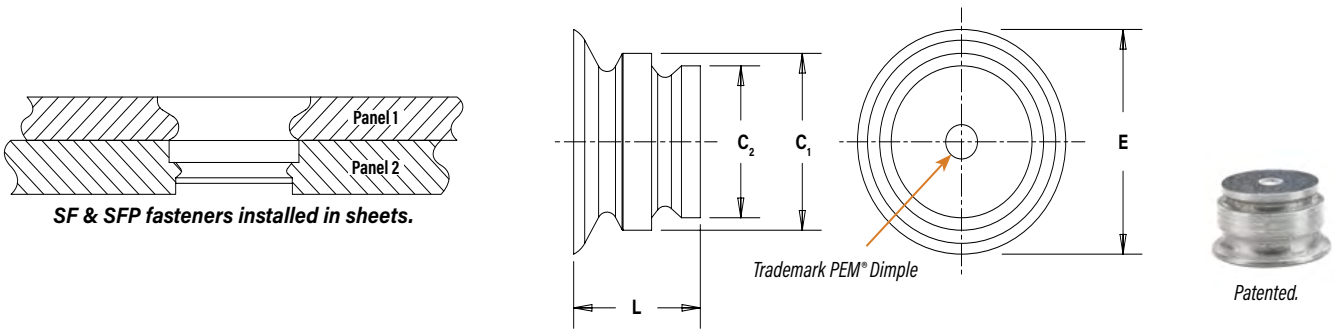

### SF™ Fastener

Type and Size	Thickness Code	Panel 1				Panel 2				C <sub>1</sub> Max.		C <sub>2</sub> Max.		E Max.		L Max.		Min. Dist. Hole $\phi$ To Edge	
		Thickness $\pm 0.08$ mm / $\pm .003$ "		Mounting Hole $+0.08$ mm / $+ .003$ " $- .000$ "		Thickness Min. (1)		Mounting Hole $+0.08$ mm / $+ .003$ " $- .000$ "		mm	in.	mm	in.	mm	in.	mm	in.	mm	in.
		mm	in.	mm	in.	mm	in.	mm	in.	mm	in.	mm	in.	mm	in.	mm	in.	mm	in.
SF-3	0.8	0.8	.031	3	.118	0.8	.031	2.5	.098	2.98	.117	2.48	.097	3.53	.139	1.5	.059	2.54	.1
SF-3	1.0	1	.039	3	.118	1	.039	2.5	.098	2.98	.117	2.48	.097	3.76	.148	1.9	.075	2.54	.1
SF-3	1.2	1.2	.047	3	.118	1.2	.047	2.5	.098	2.98	.117	2.48	.097	3.76	.148	2.31	.091	2.54	.1
SF-3	1.6	1.6	.063	3	.118	1.6	.063	2.5	.098	2.98	.117	2.48	.097	3.76	.148	3.12	.123	2.54	.1
SF-5	0.8	0.8	.031	5	.197	0.8	.031	4	.157	4.98	.196	3.97	.156	5.56	.219	1.5	.059	3.6	.14
SF-5	1.0	1	.039	5	.197	1	.039	4	.157	4.98	.196	3.97	.156	5.56	.219	1.9	.075	3.6	.14
SF-5	1.2	1.2	.047	5	.197	1.2	.047	4	.157	4.98	.196	3.97	.156	5.56	.219	2.31	.091	3.6	.14
SF-5	1.6	1.6	.063	5	.197	1.6	.063	4	.157	4.98	.196	3.97	.156	5.56	.219	3.12	.123	3.6	.14

### SFP™ Fastener for Installation Into Stainless Steel Sheets

Type and Size	Thickness Code	Panel 1				Panel 2				C <sub>1</sub> Max.		C <sub>2</sub> Max.		E Max.		L Max.		Min. Dist. Hole $\phi$ To Edge	
		Thickness $\pm 0.08$ mm / $\pm .003$ "		Mounting Hole $+0.08$ mm / $+ .003$ " $- .000$ "		Thickness Min. (1)		Mounting Hole $+0.08$ mm / $+ .003$ " $- .000$ "		mm	in.	mm	in.	mm	in.	mm	in.	mm	in.
		mm	in.	mm	in.	mm	in.	mm	in.	mm	in.	mm	in.	mm	in.	mm	in.	mm	in.
SFP-3	1.0	1	.039	3	.118	1	.039	2.5	.098	2.98	.117	2.48	.097	3.76	.148	1.9	.075	2.54	.1
SFP-3	1.2	1.2	.047	3	.118	1.2	.047	2.5	.098	2.98	.117	2.48	.097	3.76	.148	2.31	.091	2.54	.1
SFP-3	1.6	1.6	.063	3	.118	1.6	.063	2.5	.098	2.98	.117	2.48	.097	3.76	.148	3.12	.123	2.54	.1
SFP-5	1.0	1	.039	5	.197	1	.039	4.5	.177	4.98	.196	4.47	.176	5.56	.219	1.9	.075	3.6	.14
SFP-5	1.2	1.2	.047	5	.197	1.2	.047	4.5	.177	4.98	.196	4.47	.176	5.56	.219	2.31	.091	3.6	.14
SFP-5	1.6	1.6	.063	5	.197	1.6	.063	4.5	.177	4.98	.196	4.47	.176	5.56	.219	3.12	.123	3.6	.14

(1) Fastener will provide flush application at minimum sheet thickness.

## SFW™ FASTENER WITH WAVE WASHER FOR SINGLE POINT HINGING APPLICATIONS

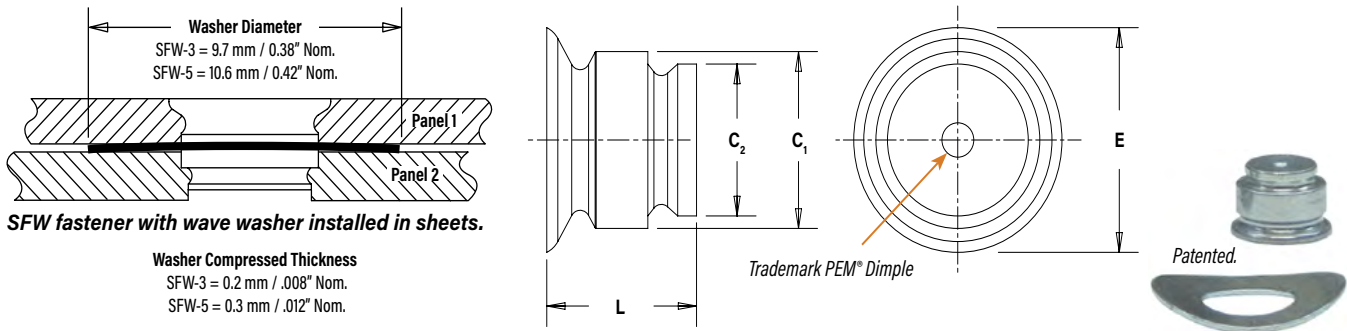

Type and Size (2)	Thickness Code	Panel 1				Panel 2				C <sub>1</sub> Max.		C <sub>2</sub> Max.		E Max.		L Max.		Min. Dist. Hole $\phi$ To Edge	
		Thickness $\pm 0.08$ mm / $\pm .003$ "		Mounting Hole $+0.08$ mm / $+ .003$ " - $-.000$ "		Thickness Min. (1)		Mounting Hole $+0.08$ mm / $+ .003$ " - $-.000$ "		mm	in.	mm	in.	mm	in.	mm	in.	mm	in.
		mm	in.	mm	in.	mm	in.	mm	in.	mm	in.	mm	in.	mm	in.	mm	in.	mm	in.
SFW-3	0.8	0.8	.031	3	.118	0.8	.031	2.5	.098	2.98	.117	2.48	.097	3.53	.139	2.09	.082	2.54	.1
SFW-3	1.0	1	.039	3	.118	1	.039	2.5	.098	2.98	.117	2.48	.097	3.76	.148	2.49	.098	2.54	.1
SFW-3	1.2	1.2	.047	3	.118	1.2	.047	2.5	.098	2.98	.117	2.48	.097	3.76	.148	2.90	.114	2.54	.1
SFW-3	1.6	1.6	.063	3	.118	1.6	.063	2.5	.098	2.98	.117	2.48	.097	3.76	.148	3.71	.146	2.54	.1
SFW-5	0.8	0.8	.031	5	.197	0.8	.031	4	.157	4.98	.196	3.97	.156	5.56	.219	1.98	.078	3.6	.14
SFW-5	1.0	1	.039	5	.197	1	.039	4	.157	4.98	.196	3.97	.156	5.56	.219	2.39	.094	3.6	.14
SFW-5	1.2	1.2	.047	5	.197	1.2	.047	4	.157	4.98	.196	3.97	.156	5.56	.219	2.79	.110	3.6	.14
SFW-5	1.6	1.6	.063	5	.197	1.6	.063	4	.157	4.98	.196	3.97	.156	5.56	.219	3.61	.142	3.6	.14

(1) Fastener will provide flush application at minimum sheet thickness. (2) SFW fasteners are shipped with mating washers.

## SFK™ FASTENER FOR JOINING METAL TO PCB/PLASTIC PANELS

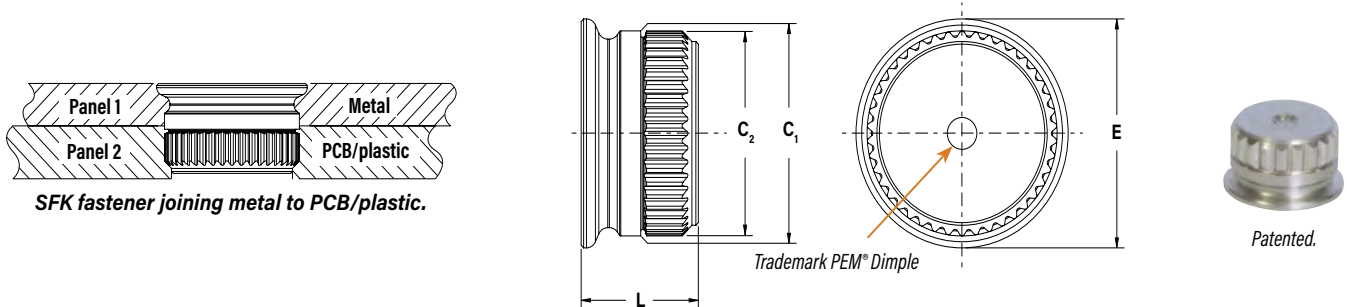

Type and Size	Thickness Code	Panel 1				Panel 2				C <sub>1</sub> Max.		C <sub>2</sub> $\pm 0.08$ mm / $\pm .003$ "		E Max.		L Max.		Min. Dist. Hole $\phi$ To Edge	
		Thickness $\pm 0.08$ mm / $\pm .003$ "		Mounting Hole $+0.08$ mm / $+ .003$ " - $-.000$ "		Thickness Min. (1)		Mounting Hole $+0.08$ mm / $+ .003$ " - $-.000$ "		mm	in.	mm	in.	mm	in.	mm	in.	mm	in.
		mm	in.	mm	in.	mm	in.	mm	in.	mm	in.	mm	in.	mm	in.	mm	in.	mm	in.
SFK-3	0.8	0.8	.031	3	.118	1.6	.063	2.5	.098	2.98	.117	2.9	.114	3.53	.139	2.31	.091	3	.012
SFK-3	1.0	1	.039	3	.118	1.6	.063	2.5	.098	2.98	.117	2.9	.114	3.76	.148	2.51	.099	3	.012
SFK-3	1.2	1.2	.047	3	.118	1.6	.063	2.5	.098	2.98	.117	2.9	.114	3.76	.148	2.72	.107	3	.012
SFK-3	1.6	1.6	.063	3	.118	1.6	.063	2.5	.098	2.98	.117	2.9	.114	3.76	.148	3.12	.123	3	.012
SFK-5	0.8	0.8	.031	5	.197	1.6	.063	4.5	.177	4.98	.196	4.9	.193	5.56	.219	2.31	.091	5.1	0.20
SFK-5	1.0	1	.039	5	.197	1.6	.063	4.5	.177	4.98	.196	4.9	.193	5.56	.219	2.51	.099	5.1	0.20
SFK-5	1.2	1.2	.047	5	.197	1.6	.063	4.5	.177	4.98	.196	4.9	.193	5.56	.219	2.72	.107	5.1	0.20
SFK-5	1.6	1.6	.063	5	.197	1.6	.063	4.5	.177	4.98	.196	4.9	.193	5.56	.219	3.12	.123	5.1	0.20

(1) Fastener will provide flush application at minimum sheet thickness.

## MATERIAL AND FINISH SPECIFICATIONS

Type	Fastener Materials		Standard Finishes			For Use in Sheet Hardness: (2)	
	Hardened Carbon Steel	Precipitation Hardening Grade Stainless Steel	Passivated and/or Tested Per ASTM A380	Zinc Plated per ASTM B633, SCl (5µm), Type III, Colorless (1)	Zinc Plated per ASTM B633, SCl (5µm), Type III, Colorless Plus Sealant/Lubricant (1)	HRB 80 / HB 150 or Less	HRB 88 / HB 183 or Less
SF	▪			▪		▪	
SFP		▪	▪				▪
SFW	▪			(Washer)	▪ (Fastener)	▪	
SFK	▪			▪		▪	
Part Number Code For Finishes			None	ZI	LZ		

(1) See PEM Technical Support section of our web site for related plating standards and specifications.

(2) HRB - Hardness Rockwell "B" Scale. HB - Hardness Brinell.

## INSTALLATION

### SF™ AND SFP™ FASTENERS

- Step 1.** Prepare properly sized mounting hole in both panels. Do not perform any secondary operations such as deburring. If the hole is punched, be sure to install fastener into punched side of hole.
- Step 2.** Place Panel 2 with smaller mounting hole on anvil and align Panel 1 mounting hole with the mounting hole of Panel 2. Place the smaller diameter end of the fastener through the mounting holes as shown in the drawing to the right. (See figure SF-1).
- Step 3.** With the punch and anvil surfaces parallel, apply squeezing force until the fastener is flush with the top of Panel 1. (See figure SF-1).

**NOTE:** To use SF or SFP fasteners as a flush-mounted pivot point, for best results, install SpotFast fastener into Panel 1 first, then place Panel 2 over fastener and squeeze again.

### PEMSERTER® Installation Tooling

Size	Punch Part No.	Anvil Part No.
SF-3 / SF-5	975200048	975200046

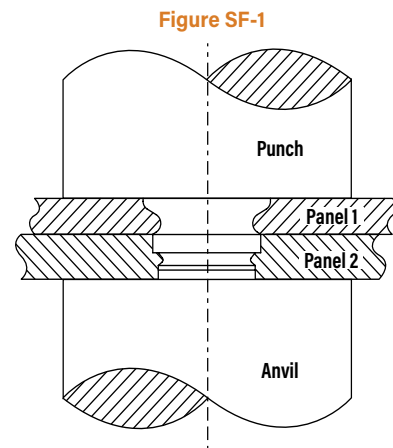

### SFW™ FASTENERS

- Step 1.** Prepare properly sized mounting hole in both panels. Do not perform any secondary operations such as deburring. If the hole is punched, be sure to install fastener into punched side of hole.
- Step 2.** Using only Panel 1, with the punch and anvil surfaces parallel, apply squeezing force until the fastener is flush with the top of Panel 1. (See figure SFW-1).
- Step 3.** To ensure proper function of washer, place washer over installed fastener (concave side facing up), then place Panel 2 over fastener. Apply squeezing force. Keep gap between Panel 2 and anvil. (See "G" in figure SFW-2).

Figure SFW-1

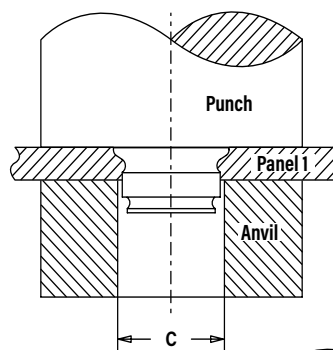
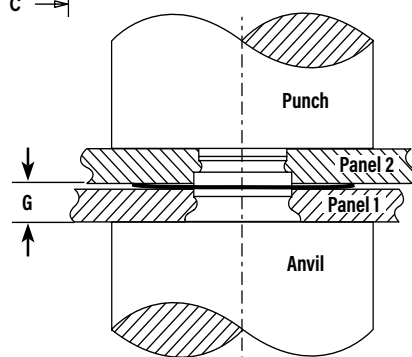

Figure SFW-2



### PEMSERTER® Installation Tooling

Size	C +0.08/+0.003 (mm) / (in.)	Punch Part No.	Part Number For Anvil Used In Step 2	Part Number For Anvil Used In Step 3
SFW-3	3.05 / .120	975200048	970200229300	975200046
SFW-5	5.05 / .199	975200048	970200020300	975200046

Size	G (mm) / (in.)
SFW-3-0.8	1.09-1.25 / .043-.049
SFW-5-0.8	1.3-1.44 / .051-.057
SFW-3-1.2	1.5-1.65 / .059-.065
SFW-5-1.2	1.91-2.06 / .075-.081

## INSTALLATION

### SFK™ FASTENER

- Step 1.** Prepare properly sized mounting hole in both panels. Do not perform any secondary operations such as deburring. If the hole is punched, be sure to install fastener into punched side of hole.
- Step 2.** Using only Panel 1, with the punch and anvil surfaces parallel, apply squeezing force until the fastener is flush with the top of Panel 1. (See figure SFK-1).
- Step 3.** Place Panel 2 over fastener and apply squeezing force. (See figure SFK-2).

Figure SFK-1

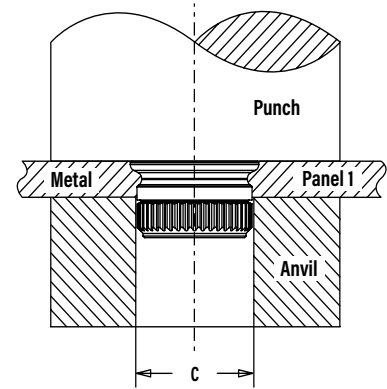
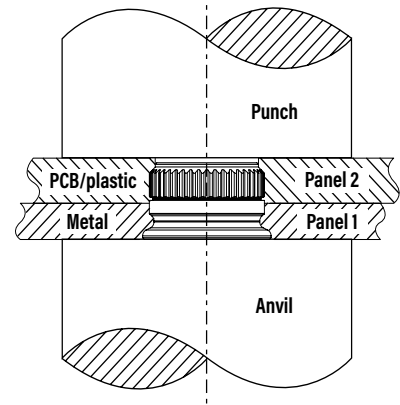

Figure SFK-2



### PEMSERTER® Installation Tooling

Size	C +0.08/+0.003 (mm) / (in.)	Punch Part No.	Part Number For Anvil Used In Step 2	Part Number For Anvil Used In Step 3
SFW-3	3.05 / .120	975200048	970200229300	975200046
SFW-5	5.05 / .199	975200048	970200020300	975200046

#### INSTALLATION NOTES

- For best results we recommend using a HAEGER® or PEMSERTER® machine for installation of PEM self-clinching fasteners. Please check our website for more information.
- Visit the Animation Library on our website to view the installation process [for select products](#).

## PERFORMANCE DATA<sup>(1)</sup>

### SF™ FASTENER

Type and Size	Thickness Code	Installation				Pushout of Panel 2 <sup>(2)</sup>			
		Cold-rolled Steel		Aluminum		Cold-rolled Steel		Aluminum	
		kN	lbs.	kN	lbs.	N	lbs.	N	lbs.
SF-3	0.8	8	1800	6	1350	360	80	200	45
SF-3	1.0	9	2025	6.5	1475	525	115	250	55
SF-3	1.2	11	2475	7	1575	555	125	310	70
SF-3	1.6	13	2925	7.5	1700	920	205	550	125
SF-5	0.8	11	2475	8	1800	625	140	310	70
SF-5	1.0	12	2700	9.5	2150	800	180	515	115
SF-5	1.2	18	4050	10	2250	1200	270	770	170
SF-5	1.6	20	4500	12.5	2825	1500	335	1145	255

### SFP™ FASTENER

Type and Size	Thickness Code	Stainless Steel			
		Installation		Pushout of Panel 2 <sup>(2)</sup>	
		kN	lbs.	N	lbs.
SFP-3	1.0	13.5	3000	620	140
SFP-3	1.2	20	4500	830	186
SFP-3	1.6	22	5000	1500	340
SFP-5	1.0	18	4000	990	222
SFP-5	1.2	27	6000	1158	260
SFP-5	1.6	33	7500	3117	701

(1) Published installation forces are for general reference. Actual set-up and confirmation of complete installation should be made by observing proper seating of fastener as described in the installation steps. Other performance values reported are averages when all proper installation parameters and procedures are followed. Variations in mounting hole size, sheet material, and installation procedure may affect performance. Performance testing this product in your application is recommended. We will be happy to provide technical assistance and/or samples for this purpose.

(2) In most applications, pullout strength of the SpotFast fastener in Panel 1 exceeds pushout strength of Panel 2.



Get quote >>

Angic Global Solutions

1-888-872-0690 [www.angic.com](http://www.angic.com) 202

<https://www.AngicGlobal.com> Sales@AngicGlobal.com

# SPOTFAST® FASTENERS

## PERFORMANCE DATA<sup>(1)</sup>

### SFW™ FASTENER

Type and Size	Thickness Code	Installation into Panel 1				Installation into Panel 2				Pushout of Panel 2 <sup>(2)</sup>			
		Cold-rolled Steel		Aluminum		Cold-rolled Steel		Aluminum		Cold-rolled Steel		Aluminum	
		kN	lbs.	kN	lbs.	kN	lbs.	kN	lbs.	N	lbs.	N	lbs.
SFW-3	0.8	4.5	1010	2.5	560	3	675	2	450	350	78	85	19
SFW-3	1.0	5.5	1240	3.5	780	4.5	1010	2	450	375	84	140	31
SFW-3	1.2	6	1350	3.5	780	5	1125	2	450	500	112	250	56
SFW-3	1.6	7	1575	4	900	6	1350	2.5	560	780	175	340	76
SFW-5	0.8	7	1575	3.5	780	8	1800	4	900	350	78	270	61
SFW-5	1.0	7	1575	3.5	780	8.5	1910	5	1125	380	153	425	96
SFW-5	1.2	7	1575	4	900	8.5	1910	5	1125	925	208	510	115
SFW-5	1.6	9	2025	5	1125	10	2250	5	1125	1450	326	600	135

### SFK™ FASTENER

Type and Size	Thickness Code	Installation into Panel 1		Installation into Panel 2		Pushout of Panel 2 <sup>(2)</sup>	
		Cold-rolled Steel		FR-4 Fiberglass			
		kN	lbs.	kN	lbs.	N	lbs.
SFK-3	0.8	6.2	1400	1.8	400	200	45
SFK-3	1.0	8	1800	1.8	400	200	45
SFK-3	1.2	8.9	2000	1.8	400	200	45
SFK-3	1.6	10.2	2300	1.8	400	200	45
SFK-5	0.8	11.1	2500	1.8	400	400	90
SFK-5	1.0	13.5	3000	1.8	400	400	90
SFK-5	1.2	15.6	3500	1.8	400	400	90
SFK-5	1.6	17.8	4000	1.8	400	400	90

(1) Published installation forces are for general reference. Actual set-up and confirmation of complete installation should be made by observing proper seating of fastener as described in the installation steps. Other performance values reported are averages when all proper installation parameters and procedures are followed. Variations in mounting hole size, sheet material, and installation procedure may affect performance. Performance testing this product in your application is recommended. We will be happy to provide technical assistance and/or samples for this purpose.

(2) In most applications, pullout strength of the SpotFast fastener in Panel 1 exceeds pushout strength of Panel 2.

Fastener drawings and models are available at [www.pemnet.com](http://www.pemnet.com)



PEM® Dimple Trademark



PEM® KEYHOLE® fasteners are designed for quick panel attachment and reduction of loose hardware.

**NEW - SKS-R™ Fasteners**  
Provide high side-load in verticle component mounting applications



**SK™**

**SELF-CLINCHING  
KEYHOLE® FASTENERS**

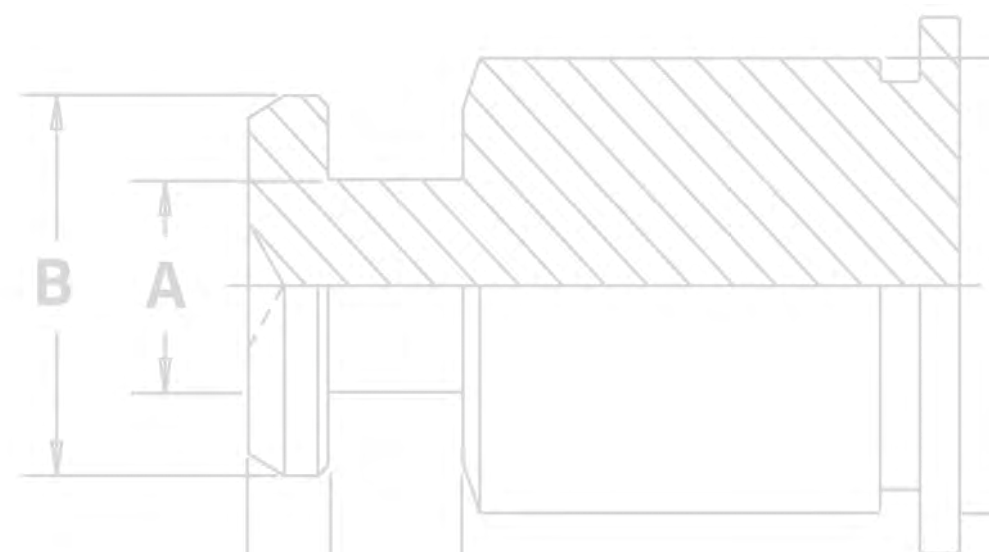

Get quote >>

Angic Global Solutions

1-888-872-0690

<https://www.AngicGlobal.com> [Sales@AngicGlobal.com](mailto:Sales@AngicGlobal.com)

# KEYHOLE® STANDOFFS AND FASTENERS

PEM® KEYHOLE® Standoffs and sheet joining fasteners are designed so that a PC board or panel can be quickly slipped into place and then removed from an assembly by simply sliding the board sideways and lifting it off. These standoffs and fasteners can save valuable time and dramatically reduce the amount of loose hardware required.

**SKC™/SK4™ standoffs** can be used for spacing or mounting of replaceable components. Typically, several standoffs are used with one standard PEM® threaded standoff which accepts a screw to secure the board or component against any unwanted movement.

- Allow detachable spacing of two sheets
- Clinch feature mounts fastener permanently and flush into metal sheet
- Unique barrel design allows for quick attachment and detachment
- Makes horizontal or vertical component mounting possible
- SK4™ standoffs are available for installation into stainless steel sheets



**SKC-F™/SK4-F™/SKS-R™ fasteners** are designed so that two sheets can be quickly joined flat against each other. Typically, several fasteners are used with one standard PEM® threaded F™ flush nut ([PEM® Bulletin F](#)) which accepts a screw to secure the sheets against any unwanted movement.

- Allow detachable spacing of two sheets
- Clinch feature mounts fastener permanently and flush or sub-flush into metal sheet
- Unique barrel design allows for quick "panel-on-panel" attachment and detachment
- Can be clinched into blind hole where concealed head is required
- Makes horizontal or vertical component mounting possible
- SK4-F™ fasteners are available for installation into stainless steel sheets
- SKS-R™ fasteners are designed to provide high side-load in verticle component mounting applications
- SKS-R™ fasteners are available for various top sheet thicknesses and hole sizes



SKC-F™/SK4-F™ Fasteners



SKS-R™ Fasteners



SKC™/SK4™ Standoffs



SKC-F™/SK4-F™ Fasteners

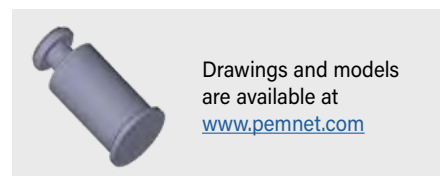

Drawings and models  
are available at  
[www.pemnet.com](http://www.pemnet.com)



PEM® Dimple  
(Registered Trademark)

# KEYHOLE® STANDOFFS AND FASTENERS

## SKC™/SK4™ STANDOFF DIMENSIONAL DATA

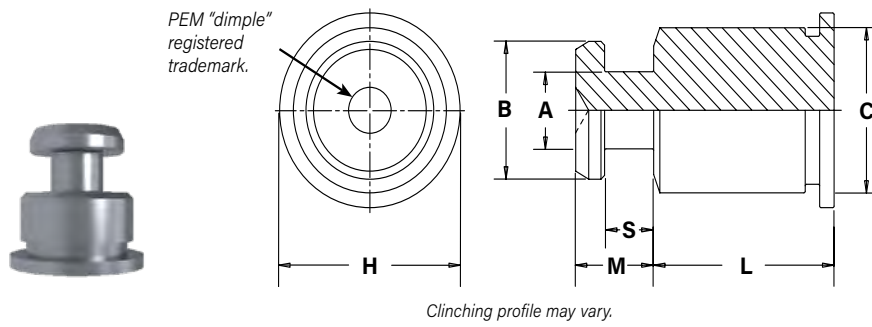

### PART NUMBER DESIGNATION

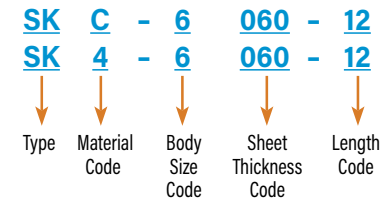

All dimensions are in inches.

UNIFIED	Type		Body Size - Sheet Code	Length "L" ± .005 (Length Code in 32nds of an inch)												A ± .003	B ± .003	C Max.	S ± .003	M Max.	H Nom.
	300 Series Stainless Steel	400 Series Stainless Steel		.063	.125	.188	.250	.312	.375	.437	.500	.562	.625	.750	.875						
	SKC	SK4	6060	2	4	6	8	10	12	14	16	18	20	24	28	32	.099	.177	.212	.068	.108

All dimensions are in millimeters.

METRIC	Type		Body Size - Sheet Code	Length "L" ± 0.13 (Length Code in millimeters)												A ± 0.08	B ± 0.08	C Max.	S ± 0.08	M Max.	H Nom.
	300 Series Stainless Steel (1)	400 Series Stainless Steel (2)		2	4	6	8	10	12	14	16	18	20	22	25						
	SKC	SK4	61.5	2	4	6	8	10	12	14	16	18	20	22	25	2.51	4.5	5.39	1.73	2.75	6.35

## SKC-F™/SK4-F™ FASTENER DIMENSIONAL DATA

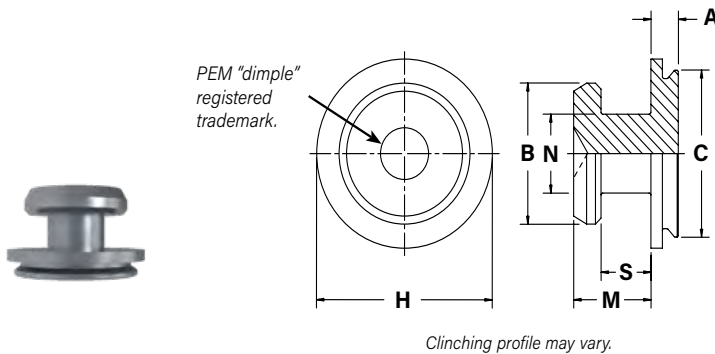

### PART NUMBER DESIGNATION

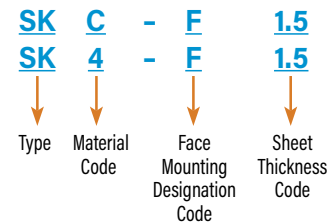

All dimensions are in inches.

UNIFIED	Type		Face Mounting Designation Code	Top Sheet Thickness Code	A Max.	B ± .003	C Max.	H Nom.	M Max.	N ± .003	S ± .003
	300 Series Stainless Steel	400 Series Stainless Steel									
	SKC	SK4	F	1.5	.039	.177	.212	.237	.108	.099	.068

All dimensions are in millimeters.

METRIC	Type		Face Mounting Designation Code	Top Sheet Thickness Code	A Max.	B ± 0.08	C Max.	H Nom.	M Max.	N ± 0.08	S ± 0.08
	300 Series Stainless Steel	400 Series Stainless Steel									
	SKC	SK4	F	1.5	1	4.5	5.39	6.02	2.75	2.5	1.73



Get quote »

Angic Global Solutions

1-888-872-0690 [www.angic.com](http://www.angic.com) 206

<https://www.AngicGlobal.com> Sales@AngicGlobal.com

# KEYHOLE® STANDOFFS AND FASTENERS

**NEW**

## SKS-R™ FASTENER DIMENSIONAL DATA

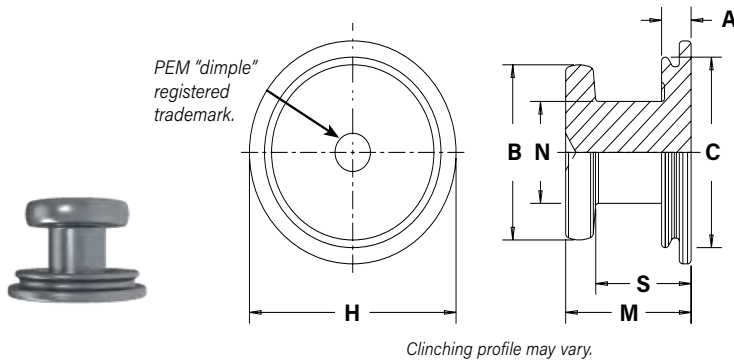

### PART NUMBER DESIGNATION

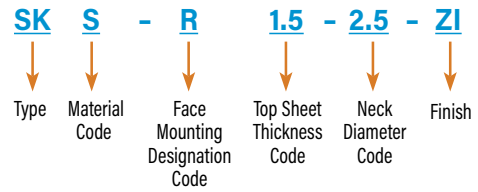

All dimensions are in inches.

UNIFIED	Type	Face Mounting Designation Code	Top Sheet Thickness Code	Neck Diameter Code	A (Shank) Max.	B ±.003	C Max.	H Nom.	M Max.	N ±.003	S +.003 - .008
	Hardened Steel										
SKS	R	1.5	2.5	.039	.177	.212	.236	.148	.099	.107	
			3.2		.217	.235	.276		.126		
			4.0		.256	.275	.307		.157		
SKS	R	2	2.5	.039	.177	.212	.236	.167	.099	.127	
			3.2		.217	.235	.276		.126		
			4.0		.256	.275	.307		.157		
SKS	R	2.5	2.5	.039	.177	.212	.236	1.87	.099	.147	
			3.2		.217	.235	.276		.126		
			4.0		.256	.275	.307		.157		

All dimensions are in millimeters.

MILLIMETERS	Type	Face Mounting Designation Code	Top Sheet Thickness Code	Neck Diameter Code	A (Shank) Max.	B ±0.08	C Max.	H Nom.	M Max.	N ±0.08	S +0.08 -0.21
	Hardened Steel										
SKS	R	1.5	2.5	1	4.5	5.39	6	3.75	2.5	2.73	
			3.2		5.5	5.98	7		3.2		
			4.0		6.5	6.98	7.8		4		
SKS	R	2	2.5	1	4.5	5.39	6	4.25	2.5	3.23	
			3.2		5.5	5.98	7		3.2		
			4.0		6.5	6.98	7.8		4		
SKS	R	2.5	2.5	1	4.5	5.39	6	4.75	2.5	3.73	
			3.2		5.5	5.98	7		3.2		
			4.0		6.5	6.98	7.8		4		



# KEYHOLE® STANDOFFS AND FASTENERS

## APPLICATION DATA

### SKC™/SK4™ STANDOFF

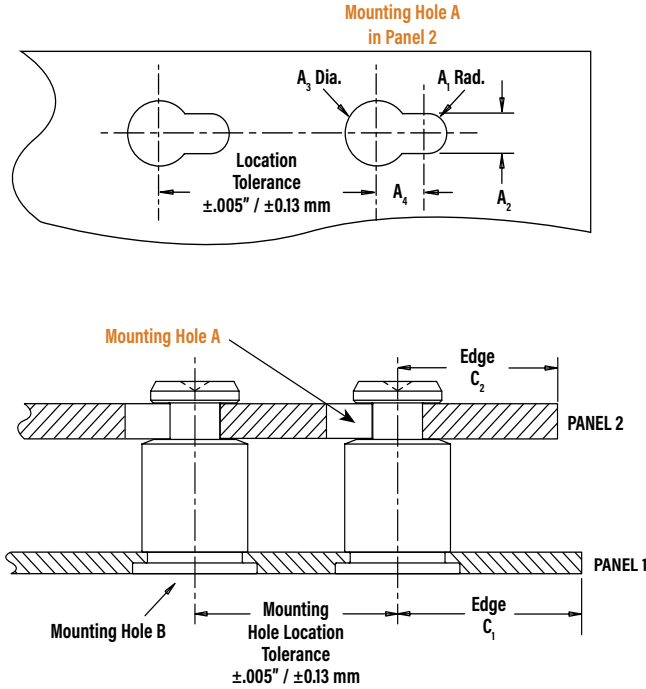

### SKC-F™/SK4-F™ FASTENER

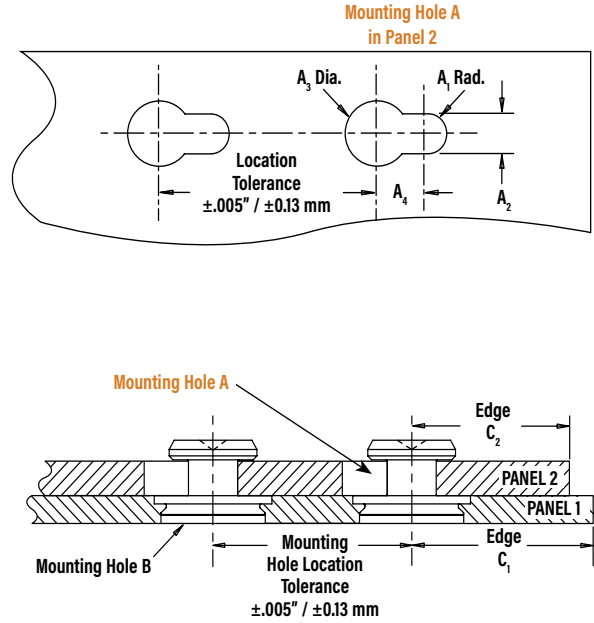

All dimensions are in inches.

UNIFIED	Type	PANEL 1				PANEL 2						
		Bottom Mounting Hole B +.003 -.000	Sheet Hardness Max. (1)	Min. Sheet Thickness	Edge Distance C <sub>1</sub> Min.	Top Mounting Hole A				Material	Thickness Range	Edge Distance C <sub>2</sub> Min.
						A <sub>1</sub> Nom.	A <sub>2</sub> ±.003	A <sub>3</sub> ±.003	A <sub>4</sub> Min.			
SKC-6060	.213	HRB 70 / HB 125	.040	.260	.059	.118	.197	.148	ANY	.057 - .064	.160	
SK4-6060	.213	HRB 88 / HB 183	.040	.260	.059	.118	.197	.148	ANY	.057 - .064	.160	
SKC-F1.5	.213	HRB 70 / HB 125	.040 <sup>(2)</sup>	.150	.059	.118	.197	.148	ANY	.057 - .064	.160	
SK4-F1.5	.213	HRB 88 / HB 183	.040 <sup>(2)</sup>	.150	.059	.118	.197	.148	ANY	.057 - .064	.160	

All dimensions are in millimeters.

METRIC	Type	PANEL 1				PANEL 2						
		Bottom Mounting Hole B +0.08	Sheet Hardness Max. (1)	Min. Sheet Thickness	Edge Distance C <sub>1</sub> Min.	Top Mounting Hole A				Material	Thickness Range	Edge Distance C <sub>2</sub> Min.
						A <sub>1</sub> Nom.	A <sub>2</sub> ± 0.08	A <sub>3</sub> ± 0.08	A <sub>4</sub> Min.			
SKC-61.5	5.41	HRB 70 / HB 125	1	6.6	1.5	3	5	3.75	ANY	1.45 - 1.62	4.1	
SK4-61.5	5.41	HRB 88 / HB 183	1	6.6	1.5	3	5	3.75	ANY	1.45 - 1.62	4.1	
SKC-F1.5	5.41	HRB 70 / HB 125	1 <sup>(2)</sup>	3.8	1.5	3	5	3.75	ANY	1.45 - 1.62	4.1	
SK4-F1.5	5.41	HRB 88 / HB 183	1 <sup>(2)</sup>	3.8	1.5	3	5	3.75	ANY	1.45 - 1.62	4.1	

(1) HRB - Hardness Rockwell "B" Scale. HB - Hardness Brinell.

(2) SKC-F™/SK4-F™ fasteners may also be installed into a .043" / 1.1 mm minimum depth blind milled hole in a .062" / 1.6 mm minimum sheet thickness.



Get quote >>

Angic Global Solutions

1-888-872-0690 [www.angic.com](http://www.angic.com) 208

<https://www.AngicGlobal.com> Sales@AngicGlobal.com

# KEYHOLE® STANDOFFS AND FASTENERS

## APPLICATION DATA

### SKS-R™ FASTENER

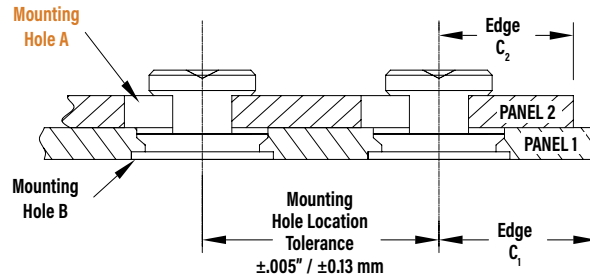
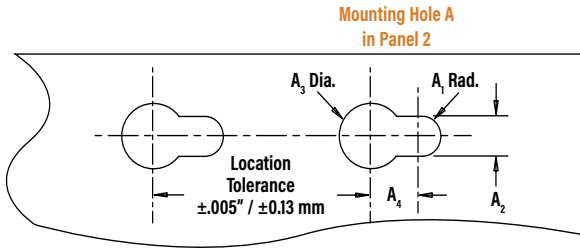

All dimensions are in inches.

UNIFIED	Type	PANEL 1				PANEL 2						
		Bottom Mounting Hole B +.003 -.000	Sheet Hardness Max. (1)	Thickness Range	Edge Distance C <sub>1</sub> Min.	Top Mounting Hole A				Material	Thickness Max.	Edge Distance C <sub>2</sub> Min.
						A <sub>1</sub> Nom.	A <sub>2</sub> ± .003	A <sub>3</sub> ± .003	A <sub>4</sub> Min.			
SKS-R1.5-2.5-ZI	.213	HRB 80 / HB 150	.040 - .047	.236	.059	.118	.197	.148	ANY	.060	.160	
SKS-R1.5-3.2-ZI	.236	HRB 80 / HB 150	.040 - .047	.236	.073	.146	.236	.181	ANY	.060	.201	
SKS-R1.5-4.0-ZI	.276	HRB 80 / HB 150	.040 - .047	.236	.089	.177	.276	.217	ANY	.060	.240	
SKS-R2.0-2.5-ZI	.213	HRB 80 / HB 150	.040 - .047	.236	.059	.118	.197	.148	ANY	.080	.160	
SKS-R2.0-3.2-ZI	.236	HRB 80 / HB 150	.040 - .047	.236	.073	.146	.236	.181	ANY	.080	.201	
SKS-R2.0-4.0-ZI	.276	HRB 80 / HB 150	.040 - .047	.236	.089	.177	.276	.217	ANY	.080	.240	
SKS-R2.5-2.5-ZI	.213	HRB 80 / HB 150	.040 - .047	.236	.059	.118	.197	.148	ANY	.100	.160	
SKS-R2.5-3.2-ZI	.236	HRB 80 / HB 150	.040 - .047	.236	.073	.146	.236	.181	ANY	.100	.201	
SKS-R2.5-4.0-ZI	.276	HRB 80 / HB 150	.040 - .047	.236	.089	.177	.276	.217	ANY	.100	.240	

All dimensions are in millimeters.

MILLIMETERS	Type	PANEL 1				PANEL 2						
		Bottom Mounting Hole B + 0.08	Sheet Hardness Max. (1)	Thickness Range	Edge Distance C <sub>1</sub> Min.	Top Mounting Hole A				Material	Thickness Max.	Edge Distance C <sub>2</sub> Min.
						A <sub>1</sub> Nom.	A <sub>2</sub> ± 0.08	A <sub>3</sub> ± 0.08	A <sub>4</sub> Min.			
SKS-R1.5-2.5-ZI	5.41	HRB 80 / HB 150	1 - 1.19	6	1.5	3	5	3.75	ANY	1.54	4.1	
SKS-R1.5-3.2-ZI	6	HRB 80 / HB 150	1 - 1.19	6	1.85	3.7	6	4.6	ANY	1.54	5.1	
SKS-R1.5-4.0-ZI	7	HRB 80 / HB 150	1 - 1.19	6	2.25	4.5	7	5.5	ANY	1.54	6.1	
SKS-R2.0-2.5-ZI	5.41	HRB 80 / HB 150	1 - 1.19	6	1.5	3	5	3.75	ANY	2.04	4.1	
SKS-R2.0-3.2-ZI	6	HRB 80 / HB 150	1 - 1.19	6	1.85	3.7	6	4.6	ANY	2.04	5.1	
SKS-R2.0-4.0-ZI	7	HRB 80 / HB 150	1 - 1.19	6	2.25	4.5	7	5.5	ANY	2.04	6.1	
SKS-R2.5-2.5-ZI	5.41	HRB 80 / HB 150	1 - 1.19	6	1.5	3	5	3.75	ANY	2.54	4.1	
SKS-R2.5-3.2-ZI	6	HRB 80 / HB 150	1 - 1.19	6	1.85	3.7	6	4.6	ANY	2.54	5.1	
SKS-R2.5-4.0-ZI	7	HRB 80 / HB 150	1 - 1.19	6	2.25	4.5	7	5.5	ANY	2.54	6.1	

## INSTALLATION

### SKC™/SK4™ STANDOFFS

1. Prepare properly sized mounting hole in Panel 1.
2. Place the fastener through (punched side of) the mounting hole and into anvil as shown in figure 1.
3. With installation punch and anvil surfaces parallel, apply only enough squeezing force to embed the head flush with the panel.

### PEMSERTER® Installation Tooling

UNIFIED	Body Size	Anvil Dimension (in.)		Anvil Part Number	Punch Part Number
	Sheet Code	D	+0.003 -0.000		
	6060	.216			

METRIC	Body Size	Anvil Dimension (mm)		Anvil Part Number	Punch Part Number
	Sheet Code	D	+0.08		
	61.5	5.49			

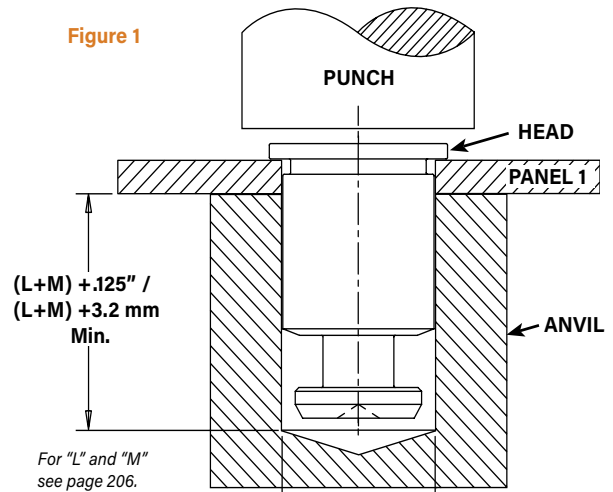

### SKC-F™/SK4-F™ FASTENERS

#### Through Hole Installation Procedure

1. Prepare properly sized mounting hole in Panel 1.
2. Place the fastener into anvil hole as shown in Figure 2.
3. Place the (punch side of) mounting hole over the shank of the fastener.
4. With installation punch and anvil surfaces parallel, apply only enough squeezing force until flange is flush with panel.

#### Blind Hole Installation Procedure

1. Mill a properly sized blind hole into Panel 1 to .043"/1.1 mm minimum depth.
2. Place the fastener into anvil hole as shown in Figure 3.
3. Place the panel mounting hole over the shank of the fastener.
4. With installation punch and anvil surfaces parallel, apply only enough squeezing force to embed the flange flush with the panel.

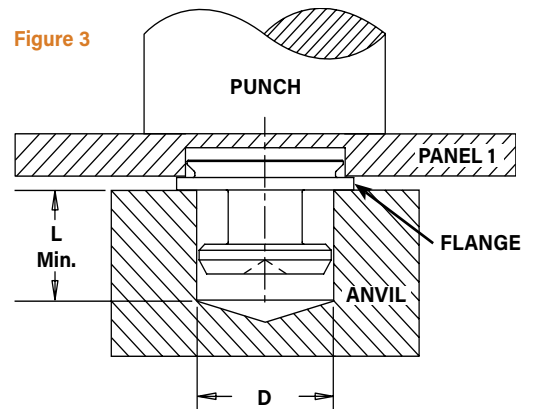
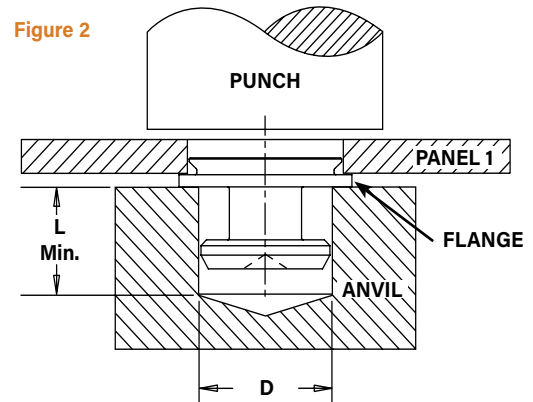

### PEMSERTER® Installation Tooling

UNIFIED	Sheet Thickness Code	Anvil Dimensions (in.)		Anvil Part Number	Punch Part Number
		L Min.	D +0.003 -0.000		
	1.5	.233	.184		

METRIC	Sheet Thickness Code	Anvil Dimensions (mm)		Anvil Part Number	Punch Part Number
		L Min.	D +0.08		
	1.5	5.95	4.67		

#### End Mill Information

Double-ended, two-flute H.S.S. center-cutting end mills are available from stock. PennEngineering does not manufacture center-cutting end mills, but we do keep a supply in stock for your convenience.



Fastener Type	Required Size End Mill	PEM Part No.
SKC-F/SK4-F	.213"	CHM-213



Get quote >>

# KEYHOLE® STANDOFFS AND FASTENERS

## SKS-R™ FASTENERS

1. Prepare properly sized mounting hole in Panel 1.
2. Place the fastener through (punch side of) the mounting hole and into anvil as shown.
3. With installation punch and anvil surfaces parallel, apply only enough squeezing force to embed the head flush with the panel.

## PEMSERTER® Installation Tooling

UNIFIED	Neck Diameter Code	Anvil Dimensions (in.)	Anvil Part Number	Punch Part Number
		D +.003 -.000		
	25	.183	8026244	975200048
	32	.222	8026245	
	40	.262	8026246	

METRIC	Neck Diameter Code	Anvil Dimensions (mm)	Anvil Part Number	Punch Part Number
		D +0.08		
	25	4.65	8026244	975200048
	32	5.65	8026245	
	40	6.65	8026246	

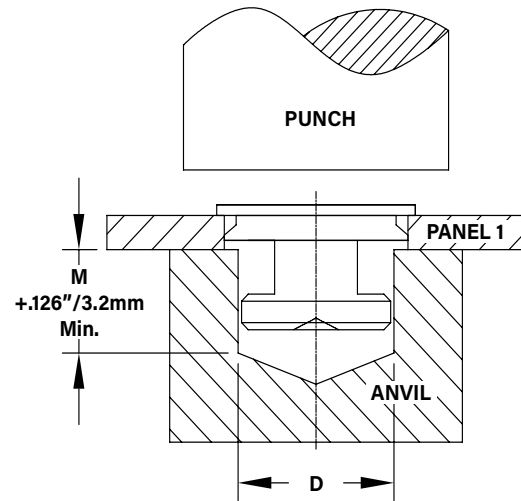

### INSTALLATION NOTES

- For best results we recommend using a [HAEGER®](#) or [PEMSERTER®](#) machine for installation of PEM® self-clinching fasteners. Please check our website for more information.
- Visit the Animation Library on our website to view the installation process [for select products](#).

## MATERIAL AND FINISH SPECIFICATIONS

Type	Fastener Materials			Standard Finish		For Use in Sheet Hardness: <sup>(1)</sup>		
	Hardened Steel	300 Series Stainless Steel	Hardened 400 Series Stainless Steel	Passivated and/or Tested per ASTM A380	Zinc Plated per ASTM B633, SC1 (5um) Type III, Colorless <sup>(2)</sup>	HRB 88 / HB 183 or less	HRB 80 / HB 150 or less	HRB 70 / HB 125 or less
SKC		▪		▪				▪
SK4			▪	▪		▪		
SKC-F		▪		▪				▪
SC4-F			▪	▪		▪		
SKS-R	▪				▪		▪	
Part Number Code For Finishes				None	ZI			

(1) HRB - Hardness Rockwell "B" Scale. HB - Hardness Brinell.

(2) See PEM Technical Support section of our web site for related plating standards and specifications.

### A NOTE ABOUT 400 SERIES FASTENERS FOR STAINLESS STEEL PANELS

In order for self-clinching fasteners to work properly, the fastener must be harder than the sheet into which it is being installed. In the case of stainless steel panels, fasteners made from 300 Series Stainless Steel do not meet this hardness criteria. It is for this reason that 400 series fasteners (SK4 and SK4-F) are offered. However, while these 400 Series fasteners install and perform well in 300 Series stainless sheets they should not be used if the end product:

- Will be exposed to any appreciable corrosive presence.
- Requires non-magnetic fasteners.
- Will be exposed to any temperatures above 300°F (149°C)

If any of these are issues, please contact [techsupport@pemnet.com](mailto:techsupport@pemnet.com) for other options.



Get quote »

Angic Global Solutions

1-888-872-0690 [www.AngicGlobal.com](https://www.AngicGlobal.com) 212

<https://www.AngicGlobal.com> Sales@AngicGlobal.com

# KEYHOLE® STANDOFFS AND FASTENERS

## PERFORMANCE DATA<sup>(1)</sup>

### SKC™/SK4™ STANDOFFS

Installation and pushout

Test Sheet Material →		.060" 5052-H34 Aluminum		.060" Cold-Rolled Steel		.060" 300 Series Stainless Steel	
UNIFIED	Body Size - Sheet Code	Installation (lbs.)	Pushout (lbs.)	Installation (lbs.)	Pushout (lbs.)	Installation (lbs.)	Pushout (lbs.)
	SKC-6060	1600	250	3200	600	—	—
	SK4-6060	—	—	—	—	9015	720

Test Sheet Material →		1.52 mm 5052-H34 Aluminum		1.52 mm Cold-Rolled Steel		1.52 mm 300 Series Stainless Steel	
METRIC	Body Size - Sheet Code	Installation (kN)	Pushout (N)	Installation (kN)	Pushout (N)	Installation (kN)	Pushout (N)
	SKC-61.5	71	1100	14.2	2600	—	—
	SK4-61.5	—	—	—	—	40.1	3200

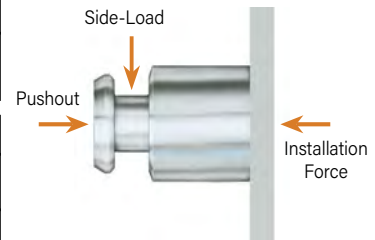

### SKC™/SK4™ STANDOFFS

Side-load

Test Sheet Thick. →		.040" <sup>(2)</sup>		.060"												
UNIFIED	Body Size - Sheet Code	Test Sheet Material	Length Codes													
			-2	-4	-6	-8	-10	-12	-14	-16	-18	-20	-24	-28	-32	
			Side-Load Force Max. (lbs.)													
			SKC-6060	5052-H34 Aluminum	130	95	82	63	52	44	38	34	30	27	22	19
SKC-6060	Cold-Rolled Steel	185	120	197	153	126	106	92	81	71	66	55	47	42		
SK4-6060	300 Series Stainless Steel	400	300	220	180	160	140	120	110	100	100	80	70	50		

Test Sheet Thick. →		1 mm <sup>(2)</sup>		1.52 mm												
METRIC	Body Size - Sheet Code	Test Sheet Material	Length Codes													
			-2	-4	-6	-8	-10	-12	-14	-16	-18	-20	-22	-25		
			Side-Load Force Max. (N)													
			SKC-61.5	5052-H34 Aluminum	545	370	296	228	184	156	136	116	104	96	88	76
SKC-61.5	Cold-Rolled Steel	735	490	696	540	440	372	320	280	252	228	208	184			
SK4-61.5	300 Series Stainless Steel	1690	1140	860	710	610	540	480	440	400	380	320	250			

### SKC-F™/SK4-F™ FASTENERS

Installation, Pushout and Side-load

Test Sheet Material →		.060" 5052-H34 Aluminum			.060" Cold-Rolled Steel			.060" 300 Series Stainless Steel		
UNIFIED	Type	Installation (lbs.)	Pushout (lbs.)	Side-Load Force Max. (lbs.)	Installation (lbs.)	Pushout (lbs.)	Side-Load Force Max. (lbs.)	Installation (lbs.)	Pushout (lbs.)	Side-Load Force Max. (lbs.)
	SKC-F	1100	120	120	2100	160	185	—	—	—
	SK4-F	—	—	—	—	—	—	10210	292	202

Test Sheet Material →		1.52 mm 5052-H34 Aluminum			1.52 mm Cold-Rolled Steel			1.52 mm 300 Series Stainless Steel		
METRIC	Type	Installation (kN)	Pushout (N)	Side-Load Force Max. (N)	Installation (kN)	Pushout (N)	Side-Load Force Max. (N)	Installation (kN)	Pushout (N)	Side-Load Force Max. (N)
	SKC-F	4.9	533	533	9.3	711	822	—	—	—
	SK4-F	—	—	—	—	—	—	45.4	1300	900

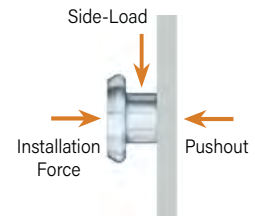

(1) Published installation forces are for general reference. Actual set-up and confirmation of complete installation should be made by observing proper seating of fastener as described in the installation steps. Other performance values reported are averages when all proper installation parameters and procedures are followed. Variations in mounting hole size, sheet material, and installation procedure may affect performance. Performance testing this product in your application is recommended. We will be happy to provide technical assistance and/or samples for this purpose.

(2) .040" / 1 mm test sheet material thickness was used for the -2 and -4 SKC/SK4 standoffs due to the short length of the parts.

## PERFORMANCE DATA

### SKS-R™ FASTENERS

#### Installation, Pushout and Side-load

Test Sheet Material →		.040" Cold-Rolled Steel HRB 67		
UNIFIED	Type	Installation (lbs.)	Pushout (lbs.)	Side-Load Force Max. (lbs.)
	SKS-R1.5-2.5-ZI	3200	160	191
	SKS-R1.5-3.2-ZI	4000	180	213
	SKS-R1.5-4.0-ZI	5000	180	258
	SKS-R2.0-2.5-ZI	3200	160	169
	SKS-R2.0-3.2-ZI	4000	180	191
	SKS-R2.0-4.0-ZI	5000	180	225
	SKS-R2.5-2.5-ZI	3200	160	124
	SKS-R2.5-3.2-ZI	4000	180	137
	SKS-R2.5-4.0-ZI	5000	180	182

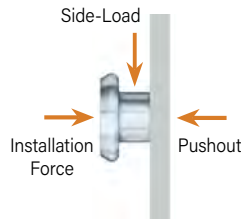

Test Sheet Material →		1 mm Cold-Rolled Steel HRB 67		
METRIC	Type	Installation (kN)	Pushout (N)	Side-Load Force Max. (N)
	SKS-R1.5-2.5-ZI	14.2	711	850
	SKS-R1.5-3.2-ZI	17.8	800	950
	SKS-R1.5-4.0-ZI	22.3	800	1150
	SKS-R2.0-2.5-ZI	14.2	711	750
	SKS-R2.0-3.2-ZI	17.8	800	850
	SKS-R2.0-4.0-ZI	22.3	800	1000
	SKS-R2.5-2.5-ZI	14.2	711	550
	SKS-R2.5-3.2-ZI	17.8	800	610
	SKS-R2.5-4.0-ZI	22.3	800	810

# KEYHOLE® STANDOFFS AND FASTENERS

212 PennE



Get quote 

Angic Global Solutions

1-888-872-0690

<https://www.AngicGlobal.com> [Sales@AngicGlobal.com](mailto:Sales@AngicGlobal.com)



PEM® through hole threaded and unthreaded standoffs for mounting, spacing or stacking panels.



**SO™**

**SELF-CLINCHING  
STANDOFFS**

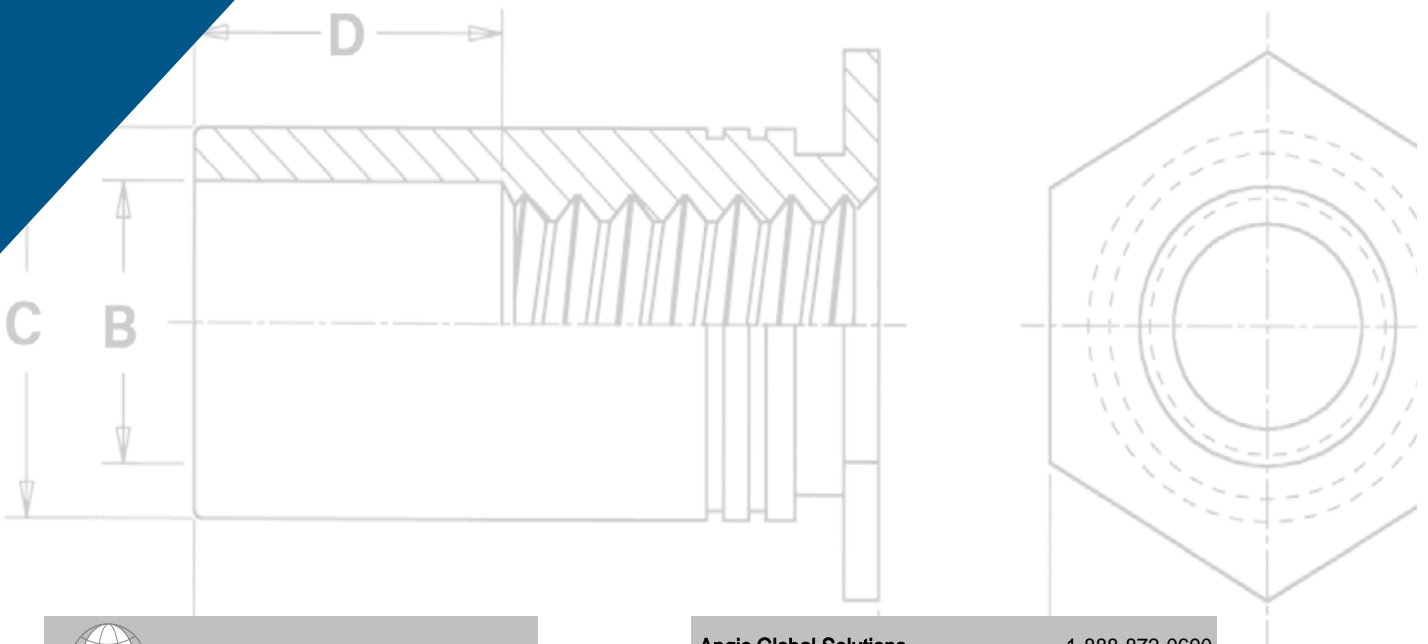

Get quote »

Angic Global Solutions

1-888-872-0690

<https://www.AngicGlobal.com> [Sales@AngicGlobal.com](mailto:Sales@AngicGlobal.com)

# SELF-CLINCHING STANDOFFS

PEM® self-clinching standoffs, which use the proven self-clinching design, provide ideal solutions for applications where mounting, spacing or stacking of panels, boards or components are required. Pressed into round holes, these fasteners mount permanently into metal sheets as thin as .025" / 0.63 mm.

Specially designed SO4™, BSO4™ and TSO4™ standoffs are made from hardened stainless steel and are ideal for clinching into stainless steel sheets. An optional nickel plating is now available if product is expected to be used in a corrosive environment.

For more information on the proper use of PEM® self-clinching standoffs, check our website for Tech Sheet [PEM® - REF/Standoff Basics](#).

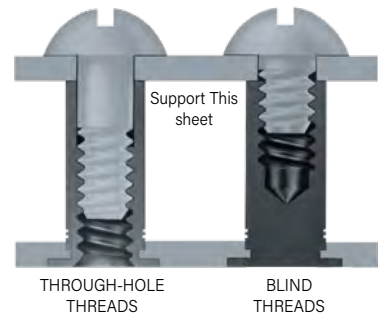

## HEAD SIDE OF SHEET AFTER INSTALLATION

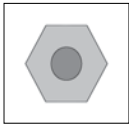

SO/SOS/SOA/SO4  
TSO/TSOS/TSOA/TSO4 (Styles 1 & 2)  
SOSG/SOAG

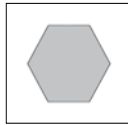

BSO/BSOS/BSOA/BSO4  
TSO/TSOS/TSOA/TSO4 (Style 3)

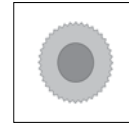

DSOS/DSO

<b>SO™/SOS™/SOA™/SO4™ through hole threaded</b> self-clinching standoffs - <b>PAGE 218</b>		<b>DSOS™/DSO™</b> Through hole, threaded standoffs with round, knurled head <b>allowing closer-to-edge clinch installation</b> - <b>PAGE 222</b>	
<b>BSO™/BSOS™/BSOA™/BSO4™ Blind hole, threaded</b> self-clinching standoffs - <b>PAGE 219</b>		<b>SOSG™/SOAG™</b> Through hole, threaded grounding standoffs with <b>"grounding/earthing teeth"</b> on end of barrel - <b>PAGE 222</b>	
<b>SO™/SOS™/SOA™/SO4™ Through hole, unthreaded</b> self-clinching standoffs - <b>PAGE 220</b>		<b>Material and finish specifications</b> - <b>PAGE 223</b>	
<b>TSO™/TSOS™/TSOA™/TSO4™</b> Through hole threaded standoffs <b>for clinching into thinner sheets</b> than SO™ standoffs - <b>PAGE 221</b>		<b>Installation</b> - <b>PAGES 223 &amp; 224</b>	
		<b>Performance data</b> - <b>PAGES 225 &amp; 226</b>	

PEM® Standoff Type	Application Requires:									
	Installation into stainless steel (1)	Superior corrosion resistance	Threads at barrel end	Closed-end for flush appearance	Grounding/earthing teeth on barrel end	Closest-to-edge distance mounting	Available Unthreaded	Thinnest minimum sheet	Most varied standard length increments	Non-magnetic
BSO			▪	▪						
BSOA			▪	▪						▪
BSOS		▪	▪	▪						▪
BSO4	▪	(2)	▪	▪						
DSO						▪				
DSOS		▪				▪				▪
SO							▪			
SOA							▪			▪
SOS		▪					▪			▪
SO4	▪	(2)					▪			
SOAG					▪					▪
SOSG		▪			▪					▪
TSO			▪	▪(3)				▪	▪	
TSOA			▪	▪(3)				▪	▪	▪
TSOS		▪	▪	▪(3)				▪	▪	▪
TSO4	▪	(2)	▪	▪(3)				▪	▪	

(1) See note 5 on page 223 about installing fasteners into stainless steel sheets.

(2) When used with optional nickel plating.

(3) Style #3 only.

# SELF-CLINCHING STANDOFFS

## SO™/SOS™/SOA™/SO4™ - THROUGH-HOLE THREADED STANDOFFS

- SO standoffs are recommended for use in steel or aluminum sheets HRB (Rockwell "B" scale) 80 / HB (Hardness Brinell) 150 or less.
- SOS standoffs are recommended for use in steel or aluminum sheets HRB (Rockwell "B" scale) 70 / HB (Hardness Brinell) 125 or less.
- SOA standoffs are recommended for use in aluminum sheets HRB (Rockwell "B" scale) 50 / HB (Hardness Brinell) 82 or less.
- SO4 standoffs are recommended for use in stainless steel sheets HRB (Rockwell "B" scale) 88 / HB (Hardness Brinell) 183 or less.

PEM® "Single" or PEM® "Two Groove" Registered Trademark

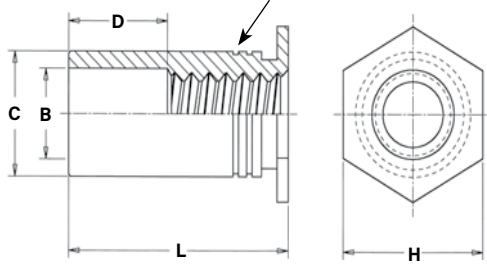

Clinching profile may vary.



SO/SOS/SOA



SO4

Installs into stainless steel

### PART NUMBER DESIGNATION

SO	-	440	-	8	ZI
SO	S	440	-	8	
SO	A	440	-	8	
SO	4	440	-	8	NC*
	↓	↓	↓	↓	↓
Type	Material Code	Thread Code	Length Code	Finish	

### GENERAL DIMENSIONAL DATA

All dimensions are in inches.

UNIFIED	Thread Code	Min. Sheet Thickness	Hole Size In Sheet +.003 -0.00	B Counter-Bore Dia. ±.005	C +.000 -0.005	H Nom.	Min. Dist. Hole $\varnothing$ To Edge	D ±.010
	440	.040	.166	.125	.165	.187	.23	Varies according to length. See length charts below.
	6440	.040	.213	.125	.212	.250	.27	
	632	.040	.213	.156	.212	.250	.27	
	8632	.050	.281	.156	.280	.312	.31	
	832	.050	.281	.188	.280	.312	.31	
032	.050	.281	.203	.280	.312	.31		

All dimensions are in millimeters.

METRIC	Thread Code	Min. Sheet Thickness	Hole Size In Sheet +0.08	B Counter-Bore Dia. ±0.13	C -0.13	H Nom.	Min. Dist. Hole $\varnothing$ To Edge	D ±0.25
	M3	1	4.22	3.2	4.2	4.8	6	Varies according to length. See length charts below.
	3.5M3	1	5.41	3.2	5.39	6.4	6.8	
	M3.5	1	5.41	3.9	5.39	6.4	6.8	
	M4	1.27	7.14	4.8	7.12	7.9	8	
	M5	1.27	7.14	5.35	7.12	7.9	8	

Micro sizes also available.

See PEM® Bulletin MPF for more information.

### THREAD SIZE AND LENGTH SELECTION DATA

All dimensions are in inches.

UNIFIED	Thread Size	Type				Thread Code	Length "L" +.002 -.005 (Length Code in 32nds of an inch)															
		Fastener Material					.125	.187	.250	.312	.375	.437	.500	.562	.625	.687	.750	.812	.875	.937	1.00	1.062
		Steel	Stainless Steel	Aluminum	Hardened Stainless Steel																	
.112-40 (#4-40)	SO	SOS	SOA	SO4	440	4	6	8	10	12	14	16	18	20	22	24	-	-	-	-	-	
					6440 <sup>(1)</sup>	4	6	8	10	12	14	16	18	20	22	24	26	28	30	32	34	
.138-32 (#6-32)	SO	SOS	SOA	SO4	632	4	6	8	10	12	14	16	18	20	22	24	26	28	30	32	34	
					8632 <sup>(1)</sup>	4	6	8	10	12	14	16	18	20	22	24	26	28	30	32	34	
.164-32 (#8-32)	SO	SOS	SOA	SO4	832	4	6	8	10	12	14	16	18	20	22	24	26	28	30	32	34	
.190-32 (#10-32)	SO	SOS	SOA	SO4	032	4	6	8	10	12	14	16	18	20	22	24	26	28	30	32	34	
D Dimension ±.010						None			.187				.312				.437					

All dimensions are in millimeters.

METRIC	Thread Size x Pitch	Type				Thread Code	Length "L" +0.05 -0.13 (Length Code in millimeters)													
		Fastener Material					3	4	6	8	10	12	14	16	18	20	22	25		
		Steel	Stainless Steel	Aluminum	Hardened Stainless Steel															
M3 x 0.5	SO	SOS	SOA	SO4	M3	3	4	6	8	10	12	14	16	18	-	-	-			
					3.5M3 <sup>(1)</sup>	3	4	6	8	10	12	14	16	18	20	22	25			
M3.5 x 0.6	SO	SOS	SOA	SO4	M3.5	3	4	6	8	10	12	14	16	18	20	22	25			
M4 x 0.7	SO	SOS	SOA	SO4	M4	3	4	6	8	10	12	14	16	18	20	22	25			
M5 x 0.8	SO	SOS	SOA	SO4	M5	3	4	6	8	10	12	14	16	18	20	22	25			
D Dimension ±0.25						None			4				8				11			

(1) Standoffs with thread codes 6440, 8632, and 3.5M3 have a thicker wall to provide more bearing surface for the mating component or panel reducing the chance of cracking or cutting into the board.

Please contact your local PEM® distributor for availability, minimum quantity, and pricing information.



Angic Global Solutions

1-888-872-0690 [www.angic.com](http://www.angic.com) 218

<https://www.AngicGlobal.com> Sales@AngicGlobal.com

# SELF-CLINCHING STANDOFFS

## BSO™/BSOS™/BSOA™/BSO4™ - BLIND THREADED STANDOFFS

- BSO standoffs are recommended for use in steel or aluminum sheets HRB (Rockwell "B" scale) 80 / HB (Hardness Brinell) 150 or less.
- BSOS standoffs are recommended for use in steel or aluminum sheets HRB (Rockwell "B" scale) 70 / HB (Hardness Brinell) 125 or less.
- BSOA standoffs are recommended for use in aluminum sheets HRB (Rockwell "B" scale) 50 / HB (Hardness Brinell) 82 or less.
- BSO4 standoffs are recommended for use in stainless steel sheets HRB (Rockwell "B" scale) 88 / HB (Hardness Brinell) 183 or less.

PEM® "Single" or PEM® "Two Groove" Registered Trademark

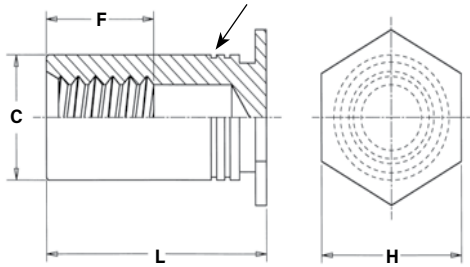

Clinching profile may vary.

### GENERAL DIMENSIONAL DATA

All dimensions are in inches.

UNIFIED	Thread Code	Min. Sheet Thickness	Hole Size In Sheet +.003 -.000	C +.000 -.005	H Nom.	Min. Dist. Hole To Edge	F Min.
	440	.040	.166	.165	.187	.23	Varies according to length. See length charts below.
	6440	.040	.213	.212	.250	.27	
	632	.040	.213	.212	.250	.27	
	8632	.050	.281	.280	.312	.31	
	832	.050	.281	.280	.312	.31	
032	.050	.281	.280	.312	.31		



BSO/BSOS/BSOA



BSO4

Installs into stainless steel

### PART NUMBER DESIGNATION

BSO	-	440	-	12	ZI
BSO	S	440	-	12	
BSO	A	440	-	12	
BSO	4	440	-	12	NC*
	↓	↓	↓	↓	↓
Type	Material Code	Thread Code	Length Code	Finish	

All dimensions are in millimeters.

METRIC	Thread Code	Min. Sheet Thickness	Hole Size In Sheet +0.08	C -0.13	H Nom.	Min. Dist. Hole To Edge	F Min.
	M3	1	4.22	4.2	4.8	6	Varies according to length. See length charts below.
	3.5M3	1	5.41	5.39	6.4	6.8	
	M3.5	1	5.41	5.39	6.4	6.8	
	M4	1.27	7.14	7.12	7.9	8	
	M5	1.27	7.14	7.12	7.9	8	

\* NC suffix is required if optional nickel plating (for corrosion resistance) is desired. Otherwise, no suffix is necessary.

### THREAD SIZE AND LENGTH SELECTION DATA

All dimensions are in inches.

UNIFIED	Thread Size	Type				Thread Code	Length "L" +.002 -.005 (Length Code in 32nds of an inch)											
		Steel	Stainless Steel	Aluminum	Hardened Stainless Steel		.312	.375	.437	.500	.562	.625	.687	.750	.812	.875	.937	1.00
	.112-40 (#4-40)	BSO	BSOS	BSOA	BSO4	440 6440 <sup>(1)</sup>	10	12	14	16	18	20	22	24	26	28	30	32
.138-32 (#6-32)	BSO	BSOS	BSOA	BSO4	632 8632 <sup>(1)</sup>	10	12	14	16	18	20	22	24	26	28	30	32	34
.164-32 (#8-32)	BSO	BSOS	BSOA	BSO4	832	10	12	14	16	18	20	22	24	26	28	30	32	34
.190-32 (#10-32)	BSO	BSOS	BSOA	BSO4	032	10	12	14	16	18	20	22	24	26	28	30	32	34
F Dimension Min.							.156	.187	.250			.375						

All dimensions are in millimeters.

METRIC	Thread Size x Pitch	Type				Thread Code	Length "L" +0.05 -0.13 (Length Code in millimeters)									
		Steel	Stainless Steel	Aluminum	Hardened Stainless Steel		6	8	10	12	14	16	18	20	22	25
M3 x 0.5	BSO	BSOS	BSOA	BSO4	M3 3.5M3 <sup>(1)</sup>	6	8	10	12	14	16	18	20	22	25	
M3.5 x 0.6	BSO	BSOS	BSOA	BSO4	M3.5	6	8	10	12	14	16	18	20	22	25	
M4 x 0.7	BSO	BSOS	BSOA	BSO4	M4	6	8	10	12	14	16	18	20	22	25	
M5 x 0.8	BSO	BSOS	BSOA	BSO4	M5	6	8	10	12	14	16	18	20	22	25	
F Dimension Min.						3.2	4		5	6.5			9.5			

(1) Standoffs with thread codes 6440, 8632, and 3.5M3 have a thicker wall to provide more bearing surface for the mating component or panel reducing the chance of cracking or cutting into the board.

Please contact your local PEM® distributor for availability, minimum quantity, and pricing information.

# SELF-CLINCHING STANDOFFS

## SO™/SOS™/SOA™/SO4™ - THROUGH-HOLE UNTHREADED STANDOFFS (SPECIAL ORDER)

- SO standoffs are recommended for use in steel or aluminum sheets HRB (Rockwell "B" scale) 80 / HB (Hardness Brinell) 150 or less.
- SOS standoffs are recommended for use in steel or aluminum sheets HRB (Rockwell "B" scale) 70 / HB (Hardness Brinell) 125 or less.
- SOA standoffs are recommended for use in aluminum sheets HRB (Rockwell "B" scale) 50 / HB (Hardness Brinell) 82 or less.
- SO4 standoffs are recommended for use in stainless steel sheets HRB (Rockwell "B" scale) 88 / HB (Hardness Brinell) 183 or less.

PEM® "Single" or PEM® "Two Groove" Registered Trademark

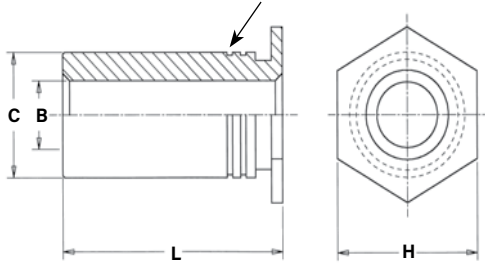

Clinching profile may vary.



SO/SOS/SOA



SO4

Installs into stainless steel

### PART NUMBER DESIGNATION

SO	-	4116	-	8	ZI
SO	S	4116	-	8	
SO	A	4116	-	8	
SO	4	4116	-	8	NC*
	↓	↓	↓	↓	↓
Type		Material Code		Thru-hole Code	Length Code
					Finish

### GENERAL DIMENSIONAL DATA

All dimensions are in inches.

UNIFIED	Thru-hole Code	Min. Sheet Thickness	Hole Size In Sheet +.003 -.000	C +.000 -.005	H Nom.	Min. Dist. Hole To Edge
	4116	.040	.166	.165	.187	.23
	6116	.040	.213	.212	.250	.27
	6143	.040	.213	.212	.250	.27
	8143	.050	.281	.280	.312	.31
	8169	.050	.281	.280	.312	.31
8194	.050	.281	.280	.280	.312	.31

All dimensions are in millimeters.

METRIC	Thru-hole Code	Min. Sheet Thickness	Hole Size In Sheet +0.08	C -0.13	H Nom.	Min. Dist. Hole To Edge
	43.1	1	4.22	4.2	4.8	6
	63.1	1	5.41	5.39	6.4	6.8
	63.6	1	5.41	5.39	6.4	6.8
	83.6	1.27	7.14	7.12	7.9	8
	84.1	1.27	7.14	7.12	7.9	8
85.1	1.27	7.14	7.12	7.9	8	

Micro sizes also available.

See PEM® [Bulletin MPF](#) for more information.

### THROUGH-HOLE AND LENGTH SELECTION DATA

All dimensions are in inches.

UNIFIED	B Thru-hole Diameter +.004 -.003	Type				Thru-hole Code	Length "L" +.002 -.005 (Length Code in 32nds of an inch)									
		Steel	Stainless Steel	Aluminum	Hardened Stainless Steel		.125	.187	.250	.312	.375	.437	.500	.562	.625	.687
	.116	SO	SOS	SOA	S04	4116 6116 <sup>(1)</sup>	4	6	8	10	12	14	16	18	20	22
.143	SO	SOS	SOA	S04	6143 8143 <sup>(1)</sup>	4	6	8	10	12	14	16	18	20	22	24
.169	SO	SOS	SOA	S04	8169	4	6	8	10	12	14	16	18	20	22	24
.194	SO	SOS	SOA	S04	8194	4	6	8	10	12	14	16	18	20	22	24

All dimensions are in millimeters.

METRIC	B Thru-hole Diameter +0.1 -0.08	Type				Thru-hole Code	Length "L" +0.05 -0.13 (Length Code in millimeters)									
		Steel	Stainless Steel	Aluminum	Hardened Stainless Steel		3	4	6	8	10	12	14	16	18	20
	3.1	SO	SOS	SOA	S04	43.1 63.1 <sup>(1)</sup>	3	4	6	8	10	12	14	16	18	20
3.6	SO	SOS	SOA	S04	63.6 83.6 <sup>(1)</sup>	3	4	6	8	10	12	14	16	18	20	
4.1	SO	SOS	SOA	S04	84.1	3	4	6	8	10	12	14	16	18	20	
5.1	SO	SOS	SOA	S04	85.1	3	4	6	8	10	12	14	16	18	20	

(1) Standoffs with thru-hole codes 6116, 8143, 63.1 and 83.6 have a thicker wall to provide more bearing surface for the mating component or panel reducing the chance of cracking or cutting into the board.

Please contact your local PEM® distributor for availability, minimum quantity, and pricing information.



Get quote

Angic Global Solutions

1-888-872-0690 [t.com 220](#)

<https://www.AngicGlobal.com> Sales@AngicGlobal.com

# SELF-CLINCHING STANDOFFS

## TSO™/TSOS™/TSOA™/TSO4™ THREADED STANDOFFS FOR SHEETS AS THIN AS .025"/0.63mm

- TSO standoffs are recommended for use in steel or aluminum sheets HRB (Rockwell "B" scale) 60 / HB (Hardness Brinell) 150 or less.
- TSOS standoffs are recommended for use in steel or aluminum sheets HRB (Rockwell "B" scale) 70 / HB (Hardness Brinell) 125 or less.
- TSOA standoffs are recommended for use in aluminum sheets HRB (Rockwell "B" scale) 50 / HB (Hardness Brinell) 82 or less.
- TSO4 standoffs are recommended for use in stainless steel sheets HRB (Rockwell "B" scale) 88 / HB (Hardness Brinell) 183 or less.

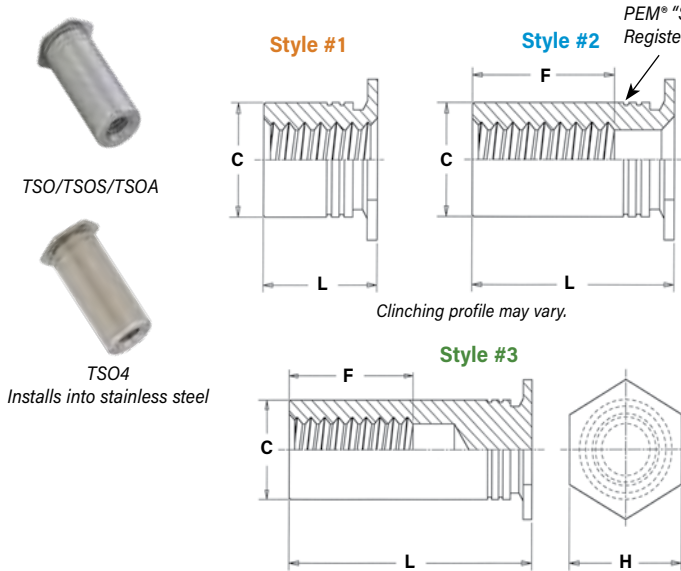

### GENERAL DIMENSIONAL DATA

All dimensions are in inches.

UNIFIED	Thread Code	Min. Sheet Thickness	Hole Size In Sheet +.003 -.000	C +.000 -.005	F Min. Thread Depth	H Nom.	Min. Dist. Hole To Edge
	256	.025	.166	.165	.200	.187	.23
6256	.025	.213	.212	.250		.27	
440	.025	.166	.165	.220	.187	.23	
6440	.025	.213	.212		.250	.27	
632	.025	.213	.212		.270	.250	.27

All dimensions are in millimeters.

METRIC	Thread Code	Min. Sheet Thickness	Hole Size In Sheet +0.08	C -0.13	F Min. Thread Depth	H Nom.	Min. Dist. Hole To Edge
	M25	0.63	4.22	4.2	5.2	4.8	5.8
6M25	0.63	5.41	5.39	6.4		7.1	
M3	0.63	4.22	4.2	6.2	4.8	5.8	
6M3	0.63	5.41	5.39		6.4	7.1	
M35	0.63	5.41	5.39	7	6.4	7.1	

### THREAD SIZE AND LENGTH SELECTION DATA

All dimensions are in inches.

UNIFIED	Thread Size	Type				Thread Code	Length "L" ±.003										
		Steel	Stainless Steel	Aluminum	Hardened Stainless Steel		For other lengths / thread depth data see chart at bottom of page.										
		.090	.125	.187	.250		.312	.375	.437	.500	.562	.625	.687	.750			
.086-56 (#2-56)	TSO	TSOS	TSOA	TSO4	256	090 <sup>(1)</sup>	125 <sup>(1)</sup>	187 <sup>(1)</sup>	250 <sup>(1)</sup>	312 <sup>(2)</sup>	375 <sup>(2)</sup>	437 <sup>(3)</sup>	500 <sup>(3)</sup>	562 <sup>(3)</sup>	625 <sup>(3)</sup>	687 <sup>(3)</sup>	750 <sup>(3)</sup>
					6256 <sup>(4)</sup>												
	440	090 <sup>(1)</sup>	125 <sup>(1)</sup>	187 <sup>(1)</sup>	250 <sup>(1)</sup>	312 <sup>(2)</sup>	375 <sup>(2)</sup>	437 <sup>(2)</sup>	500 <sup>(3)</sup>	562 <sup>(3)</sup>	625 <sup>(3)</sup>	687 <sup>(3)</sup>	750 <sup>(3)</sup>				
.112-40 (#4-40)	TSO	TSOS	TSOA	TSO4	6440 <sup>(4)</sup>	090 <sup>(1)</sup>	125 <sup>(1)</sup>	187 <sup>(1)</sup>	250 <sup>(1)</sup>	312 <sup>(2)</sup>	375 <sup>(2)</sup>	437 <sup>(2)</sup>	500 <sup>(3)</sup>	562 <sup>(3)</sup>	625 <sup>(3)</sup>	687 <sup>(3)</sup>	750 <sup>(3)</sup>
.138-32 (#6-32)	TSO	TSOS	TSOA	TSO4	632	-	125 <sup>(1)</sup>	187 <sup>(1)</sup>	250 <sup>(1)</sup>	312 <sup>(1)</sup>	375 <sup>(2)</sup>	437 <sup>(2)</sup>	500 <sup>(2)</sup>	562 <sup>(3)</sup>	625 <sup>(3)</sup>	687 <sup>(3)</sup>	750 <sup>(3)</sup>

All dimensions are in millimeters.

METRIC	Thread Size x Pitch	Type				Thread Code	Length "L" ±0.08									
		Steel	Stainless Steel	Aluminum	Hardened Stainless Steel		For other lengths / thread depth data see chart at bottom of page.									
		2.00	3.00	4.00	6.00		8.00	10.00	12.00	14.00	16.00	18.00	19.00			
M2.5 x 0.45	TSO	TSOS	TSOA	TSO4	M25	200 <sup>(1)</sup>	300 <sup>(1)</sup>	400 <sup>(1)</sup>	600 <sup>(1)</sup>	800 <sup>(2)</sup>	1000 <sup>(3)</sup>	1200 <sup>(3)</sup>	1400 <sup>(3)</sup>	1600 <sup>(3)</sup>	1800 <sup>(3)</sup>	1900 <sup>(3)</sup>
					6M25 <sup>(4)</sup>											
M3 x 0.5	TSO	TSOS	TSOA	TSO4	M3	200 <sup>(1)</sup>	300 <sup>(1)</sup>	400 <sup>(1)</sup>	600 <sup>(1)</sup>	800 <sup>(2)</sup>	1000 <sup>(2)</sup>	1200 <sup>(3)</sup>	1400 <sup>(3)</sup>	1600 <sup>(3)</sup>	1800 <sup>(3)</sup>	1900 <sup>(3)</sup>
					6M3 <sup>(4)</sup>											
M3.5 x 0.6	TSO	TSOS	TSOA	TSO4	M35	-	300 <sup>(1)</sup>	400 <sup>(1)</sup>	600 <sup>(1)</sup>	800 <sup>(1)</sup>	1000 <sup>(2)</sup>	1200 <sup>(2)</sup>	1400 <sup>(3)</sup>	1600 <sup>(3)</sup>	1800 <sup>(3)</sup>	1900 <sup>(3)</sup>

(1) Style #1. Thru-threaded.

(2) Style #2. Screw might not pass through unthreaded end. Tapped to minimum full thread depth shown. Incomplete threads on tap may allow screw to pass through.

(3) Style #3. Blind.

(4) Standoffs with thread codes 6256, 6440, 6M25 and 6M3 have a thicker wall to provide more bearing surface for the mating component or panel reducing the chance of cracking or cutting into the board.

Please contact your local PEM® distributor for availability, minimum quantity, and pricing information.

### LENGTH/STYLE DATA

All dimensions are in inches.

(Length can be specified in .001" increments.)

UNIFIED	Thread Code	Length "L" (Style #1)	Length "L" (Style #2)	Length "L" (Style #3)
	256 / 6256	.090 - .250	.251 - .375	.376 - .750
	440 / 6440	.090 - .280	.281 - .450	.451 - .750
	632	.120 - .350	.351 - .540	.541 - .750

All dimensions are in millimeters.

(Length can be specified in 0.02 mm increments.)

METRIC	Thread Code	Length "L" (Style #1)	Length "L" (Style #2)	Length "L" (Style #3)
	M25 / 6M25	2.00 - 6.30	6.32 - 9.50	9.52 - 19.00
	M3 / 6M3	2.00 - 7.50	7.52 - 11.00	11.02 - 19.00
	M35	3.00 - 8.80	8.82 - 12.80	12.82 - 19.00

### PART NUMBER DESIGNATION

TSO - 440 - 250 ZI  
 TSO S - 440 - 250  
 TSO A - 440 - 250  
 TSO 4 - 440 - 250 NC\*

Type Material Code Thread Code Length Code Finish

\* NC suffix is required if optional nickel plating (for corrosion resistance) is desired. Otherwise, no suffix is necessary.

# SELF-CLINCHING STANDOFFS

## DSOS™/DSO™ THREADED STANDOFFS - FOR CLOSE-TO-EDGE APPLICATIONS

- DSO standoffs are recommended for use in steel or aluminum sheets HRB (Rockwell "B" scale) 80 / HB (Hardness Brinell) 150 or less.
- DSOS standoffs are recommended for use in steel or aluminum sheets HRB (Rockwell "B" scale) 70 / HB (Hardness Brinell) 125 or less.

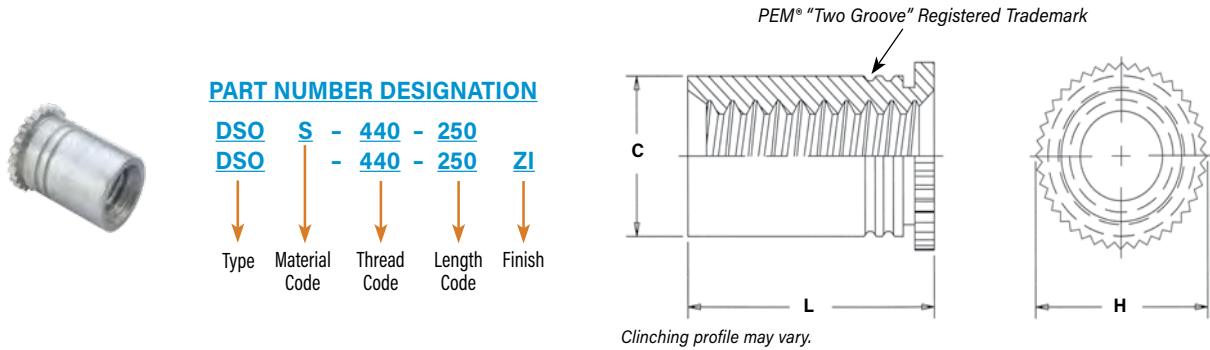

All dimensions are in inches.

UNIFIED	Thread Size	Type		Thread Code	Length Code	Sheet Thickness	Hole Size In Sheet +.003 -.000	C Max.	H Nom.	L <sup>(1)</sup> +.002 -.005	Min. Dist. Hole To Edge
		Stainless Steel	Steel								
	.112-40 (#4-40)	DSOS	DSO	440	250	.037 - .250	.166	.165	.194	.250	.126
					275					.275	

All dimensions are in millimeters.

METRIC	Thread Size x Pitch	Type		Thread Code	Length Code	Sheet Thickness	Hole Size In Sheet +0.08	C Max.	H Nom.	L <sup>(1)</sup> +0.05 -.13	Min. Dist. Hole To Edge
		Stainless Steel	Steel								
	M3 x 0.5	DSOS	DSO	M3	6.35	0.94 - 6.35	4.22	4.2	4.92	6.35	3.2
					7					7	

(1) Available in other lengths on special order.

Please contact your local PEM® distributor for availability, minimum quantity, and pricing information.

## SOSG™/SOAG™ GROUNDING/EARTHING STANDOFFS

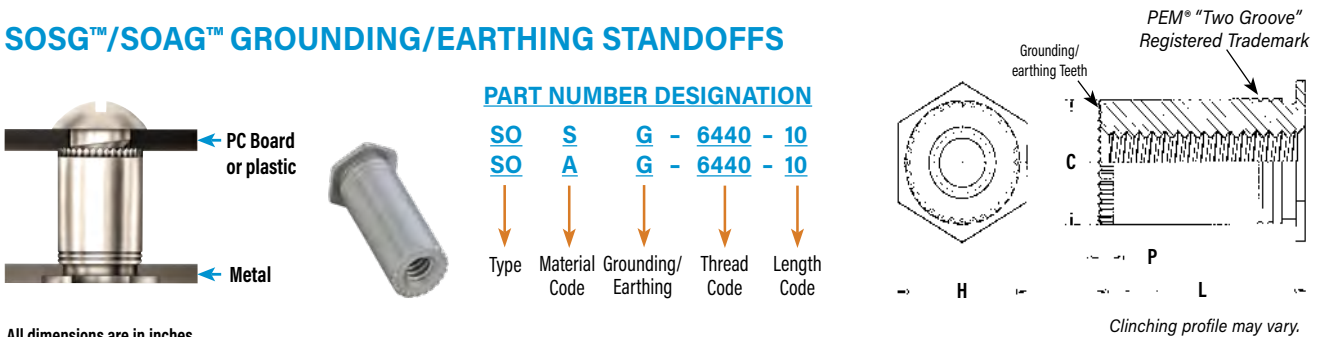

All dimensions are in inches.

UNIFIED	Thread Size	Type		Thread Code	Length "L" +.010 -.000 (Length Code is in 32nds of an inch)						Min. Sheet Thickness	Hole Size In Sheet +.003 -.000	C +.005 -.005	H ±.005	P Nom.	Min. Dist. Hole To Edge	
		Stainless Steel	Aluminum		.125	.187	.250	.312	.375	.437							.500
	.112-40 (#4-40)	SOSG	SOAG	6440	4	6	8	10	12	14	16	.040	.213	.212	.250	.030	.27
	.138-32 (#6-32)	SOSG	SOAG	8632	4	6	8	10	12	14	16	.050	.281	.280	.312	.030	.31

All dimensions are in millimeters.

METRIC	Thread Size x Pitch	Type		Thread Code	Length "L" +0.25 (Length Code is in millimeters)						Min. Sheet Thickness	Hole Size In Sheet +0.08	C -.13	H ±0.25	P Nom.	Min. Dist. Hole To Edge
		Stainless Steel	Aluminum		3	4	6	8	10	12						
	M3 x 0.5	SOSG	SOAG	3.5M3	3	4	6	8	10	12	1	5.4	5.39	6.4	0.76	6.8



Get quote >>

Angic Global Solutions

1-888-872-0690 [www.angic.com](http://www.angic.com) 222

<https://www.AngicGlobal.com> Sales@AngicGlobal.com

# SELF-CLINCHING STANDOFFS

## MATERIAL AND FINISH SPECIFICATIONS

Type	Threads <sup>(1)</sup>	Fastener Materials					Standard Finishes			Optional Finish	For Use In Sheet Hardness: <sup>(4)</sup>				
	Internal, ASME B1.1, 2B ASME B1.13M, 6H	Hardened Carbon Steel	Non-heat Treated Carbon Steel	Aluminum	300 Series Stainless Steel	Hardened 400 Series Stainless Steel (5)	Zinc Plated per ASTM B633, SC1 (5µm), Type III Colorless (2)	Passivated and/or Tested Per ASTM A380	No Finish	Electroless Nickel over Copper over Nickel Strike Per ASTM B733 (2) (3)	HRB 88 / HB 183 or Less	HRB 80 / HB 150 or Less	HRB 70 / HB 125 or Less	HRB 60 / HB 107 or Less	HRB 50 / HB 82 or Less
SO	▪	▪					▪								
SOA	▪			▪					▪						▪
SOS	▪				▪			▪					▪		
SO4	▪					▪		▪		▪	▪				
BSO	▪	▪					▪					▪			
BSOA	▪			▪					▪						▪
BSOS	▪				▪			▪				▪			
BSO4	▪					▪		▪		▪	▪				
TSO	▪		▪				▪						▪		
TSOS	▪				▪			▪				▪			
TSOA	▪			▪					▪						▪
TSO4	▪					▪		▪		▪	▪				
DSO	▪	▪					▪					▪			
DSOS	▪				▪			▪				▪			
SOAG	▪			▪					▪						▪
SOSG	▪				▪			▪				▪			
Part Number Codes For Finishes							ZI	None	None	NC					

- (1) Where applicable.
- (2) See PEM Technical Support section of our website for related plating standards and specifications.
- (3) Not stocked, available on special order. Minimum quantities apply. Contact your local PEM® distributor for details.
- (4) HRB - Hardness Rockwell "B" Scale. HB - Hardness Brinell.
- (5) In order for self-clinching fasteners to work properly, the fastener must be harder than the sheet into which it is being installed (For more information, see our [tech sheet](#) for installing fasteners into stainless steel sheets). In the case of stainless steel panels, fasteners made from 300 Series Stainless Steel do not meet this hardness criteria. It is for this reason that SO4™, BSO4™ and TSO4™ 400 series fasteners are offered. However, while these 400 Series fasteners install and perform well in 300 Series stainless sheets they should not be used if the end product will be exposed to any appreciable corrosive environment (unless finished with optional nickel plating), requires non-magnetic fasteners or will be exposed to any temperatures above 300°F (149°C). If any of these are issues, please contact [techsupport@pemnet.com](mailto:techsupport@pemnet.com) for other options.

## INSTALLATION

### SO™/SOS™/SOA™/SO4™/BSO™/BSOS™/BSOA™/BSO4™ STANDOFFS

1. Prepare properly sized mounting hole in sheet. Do not perform any secondary operation such as deburring.
2. Insert standoff through mounting hole (preferably the punch side) of sheet and into anvil as shown in drawing.
3. With installation punch and anvil surfaces parallel, apply only enough squeezing force to embed the standoff's head flush in the sheet. Drawing at right shows suggested tooling for applying these forces.

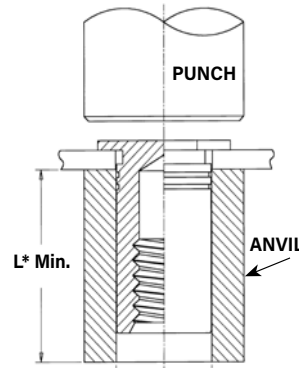

\*See pages 218 & 219 for "C" and "L":  
 +.004" to +.007" /  
 +0.1 mm to +0.18 mm

### PEMSERTER® Installation Tooling

Thread Code	Anvil Part Number	Punch Part Number
440/M2/M2.5/M3	970200487300	975200048
632/6440/3.5M3/M3.5	970200012300	
832/8632/M4	970200013300	
032/M5	970200013300	
0420/M6	970200393300	

# SELF-CLINCHING STANDOFFS

## INSTALLATION

### TSO™/TSOS™/TSOA™/TSO4™ STANDOFFS

1. Prepare properly sized mounting hole in sheet. Do not perform any secondary operation such as deburring.
2. Insert standoff through mounting hole (preferably the punch side) of sheet and into anvil as shown in drawing.
3. With installation punch and anvil surfaces parallel, apply only enough squeezing force to embed the standoff's head flush in the sheet. Drawing at right shows required installation anvil for sheet thickness of .025" to .032" / 0.63 mm to 0.81 mm. A chamfered anvil is not required for sheets over .032" / 0.81 mm.

REQUIRED INSTALLATION ANVIL FOR SHEETS BELOW .032" / 0.81 mm

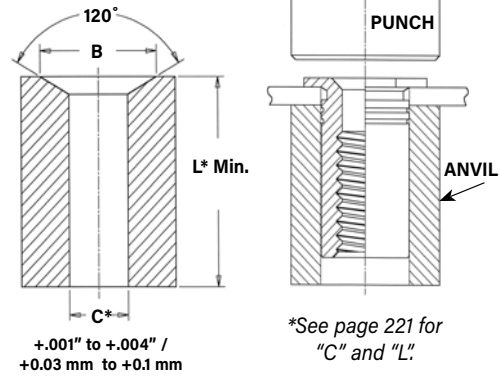

### PEMSERTER® Installation Tooling

UNIFIED	Thread Code	Anvil Dimensions (in.) For Sheets Below .032"		Anvil Part No. For Sheets Over .032"	Punch Part Number
		B	Anvil Part No.		
	256/440	.187 - .194	8003291	970200487300	975200048
6256/6440/632	.250 - .257	8003292	970200012300	975200048	

METRIC	Thread Code	Anvil Dimensions (mm) For Sheets Below 0.81 mm		Anvil Part No. For Sheets Over 0.81 mm	Punch Part Number
		B	Anvil Part No.		
	M2.5/M3	4.75 - 4.93	8003291	970200487300	975200048
6M25/6M3/M35	6.35 - 6.53	8003292	970200012300	975200048	

### DSOS™/DSO™ STANDOFFS

1. Prepare properly sized mounting hole in sheet. Do not perform any secondary operations such as deburring.
2. Insert fastener through mounting hole (preferably the punch side) and into anvil as shown in drawing.
3. With installation punch and anvil surfaces parallel, apply only enough squeezing force to embed the standoff's head flush in the sheet.

### PEMSERTER® Installation Tooling

Thread Code	Anvil Part Number	Punch Part Number
440/M3	970200487300	975200048
6440/3.5M3	970200012300	
8632	970200013300	

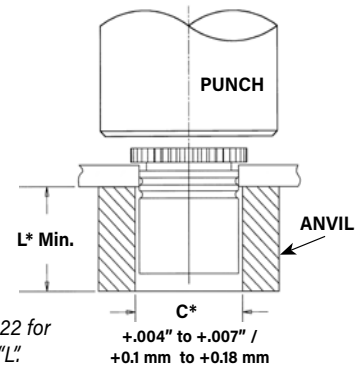

### SOSG™/SOAG™ STANDOFFS

1. Prepare properly sized mounting hole in sheet. Do not perform any secondary operations such as deburring.
2. Insert fastener through mounting hole (preferably the punch side) and into anvil as shown in drawing.
3. With installation punch and anvil surfaces parallel, apply only enough squeezing force to embed the standoff's head flush in the sheet.

### PEMSERTER® Installation Tooling

Thread Code	Anvil Part Number	Punch Part Number
440/M3	970200487300	975200048
6440/3.5M3	970200012300	
8632	970200013300	

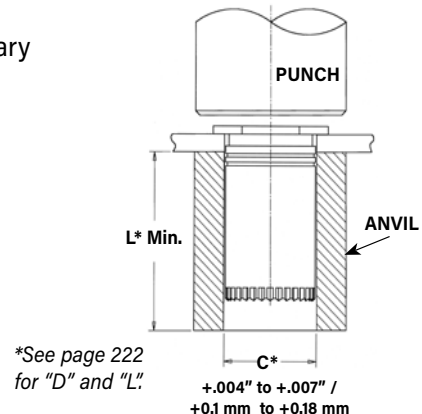

### INSTALLATION NOTES

- For best results we recommend using a Haeger® or PEMSERTER® press for installation of PEM® standoffs. Please check our website for more information.
- Visit the Animation Library on our website to view the installation process [for this product](#).



Get quote »

Angic Global Solutions

1-888-872-0690 [t.com 224](#)

<https://www.AngicGlobal.com> Sales@AngicGlobal.com

# SELF-CLINCHING STANDOFFS

## PERFORMANCE DATA<sup>(1)</sup>

### SO™/SOS™/SOA™/BSO™/BSOS™/BSOA™ STANDOFFS

UNIFIED	Thread Code	Standoff Material	Max. Rec. Tightening Torque For Mating Screw (in. lbs.)	Test Sheet Material <sup>(2)</sup>							
				.060" 5052-H34 Aluminum				.060" Cold-rolled Steel			
				Installation (lbs.)	Pushout (lbs.)	Torque-out <sup>(3)</sup> (in. lbs.)	Pull-thru <sup>(3)</sup> (lbs.)	Installation (lbs.)	Pushout (lbs.)	Torque-out <sup>(3)</sup> (in. lbs.)	Pull-thru <sup>(3)</sup> (lbs.)
440	Steel	4.75	1100	160	11	280	2200	225	19	330	
	Stainless Steel	3.8	1100	160	11	224	2200	225	19	264	
	Aluminum	2.85	1100	160	11	168	-	-	-	-	
6440	Steel	4.75	1700	300	25	310	3300	420	35	380	
	Stainless Steel	3.8	1700	300	25	248	3300	420	35	304	
	Aluminum	2.85	1700	300	25	186	-	-	-	-	
632	Steel	8.75	1700	300	25	310	3300	420	35	380	
	Stainless Steel	7	1700	300	25	248	3300	420	35	304	
	Aluminum	5.25	1700	300	25	186	-	-	-	-	
8632	Steel	8.75	2400	400	45	580	4000	560	75	700	
	Stainless Steel	7	2400	400	45	464	4000	560	75	560	
	Aluminum	5.25	2400	400	45	248	-	-	-	-	
832	Steel	18	2400	400	45	580	4000	560	75	700	
	Stainless Steel	14.4	2400	400	45	464	4000	560	75	560	
	Aluminum	11	2400	400	45	348	-	-	-	-	
032	Steel	32	2400	400	45	580	4000	560	75	700	
	Stainless Steel	25.6	2400	400	45	464	4000	560	75	560	
	Aluminum	19	2400	400	45	348	-	-	-	-	

METRIC	Thread Code	Standoff Material	Max. Rec. Tightening Torque For Mating Screw (N-m)	Test Sheet Material <sup>(2)</sup>							
				1.5 mm 5052-H34 Aluminum				1.5 mm Cold-rolled Steel			
				Installation (kN)	Pushout (N)	Torque-out <sup>(3)</sup> (N-m)	Pull-thru <sup>(3)</sup> (N)	Installation (kN)	Pushout (N)	Torque-out <sup>(3)</sup> (N-m)	Pull-thru <sup>(3)</sup> (N)
M3	Steel	0.55	4.9	710	1.24	1245	9.8	1000	2.15	1465	
	Stainless Steel	0.44	4.9	710	1.24	996	9.8	1000	2.15	1172	
	Aluminum	0.33	4.9	710	1.24	747	-	-	-	-	
3.5M3	Steel	0.55	7.6	1330	2.82	1375	14.7	1860	3.95	1690	
	Stainless Steel	0.44	7.6	1330	2.82	1100	14.7	1860	3.95	1352	
	Aluminum	0.33	7.6	1330	2.82	825	-	-	-	-	
M3.5	Steel	0.91	7.6	1330	2.82	1375	14.7	1860	3.95	1690	
	Stainless Steel	0.73	7.6	1330	2.82	1100	14.7	1860	3.95	1352	
	Aluminum	0.55	7.6	1330	2.82	825	-	-	-	-	
M4	Steel	2	10.7	1780	5.08	2575	17.8	2490	8.47	3110	
	Stainless Steel	1.6	10.7	1780	5.08	2060	17.8	2490	8.47	2488	
	Aluminum	1.2	10.7	1780	5.08	1545	-	-	-	-	
M5	Steel	3.6	10.7	1780	5.08	2575	17.8	2490	8.47	3110	
	Stainless Steel	2.88	10.7	1780	5.08	2060	17.8	2490	8.47	2488	
	Aluminum	2.16	10.7	1780	5.08	1545	-	-	-	-	

### SO4™/BSO4™ STANDOFFS

UNIFIED	Thread Code	Max. Rec. Tightening Torque For Mating Screw (in. lbs.)	Test Sheet Material			
			.050" 300 Series Stainless Steel			
			Installation (lbs.)	Pushout (lbs.)	Torque-out (in. lbs.) <sup>(2)</sup>	Pull-thru (lbs.) <sup>(2)</sup>
440	4.75	5500	336	17	600	
6440	4.75	9500	647	30	680	
632	8.75	9500	647	30	680	
8632	8.75	10500	900	71	1392	
832	18	10500	900	71	1517	
032	32	10500	900	71	1368	

METRIC	Thread Code	Max. Rec. Tightening Torque For Mating Screw (N-m)	Test Sheet Material			
			1.3 mm 300 Series Stainless Steel			
			Installation (kN)	Pushout (N)	Torque-out (N-m) <sup>(2)</sup>	Pull-thru (N) <sup>(2)</sup>
M3	0.55	24.5	1493	2.36	2650	
3.5M3	0.55	42.3	2877	3.06	3025	
M3.5	0.91	42.3	2877	3.06	3025	
M4	2	46.7	4003	8.89	6458	
M5	3.6	46.7	4003	8.89	6226	

(1) Published installation forces are for general reference. Actual set-up and confirmation of complete installation should be made by observing proper seating of fastener as described in the installation steps. Other performance values reported are averages when all proper installation parameters and procedures are followed. Variations in mounting hole size, sheet material, and installation procedure may affect performance. Performance testing this product in your application is recommended. We will be happy to provide technical assistance and/or samples for this purpose.

(2) See [tech sheet](#) on our website for performance data of PEM® SO™ standoffs installed into copper sheets.

(3) Joint failure in torque-out and pull-thru will depend on the strength and type of screw being used. In some cases the failure will be in the screw and not in the self-clinching standoff. Please contact our Applications Engineering group with any questions.

# SELF-CLINCHING STANDOFFS

## PERFORMANCE DATA<sup>(1)</sup>

### TSO™/TSOS™/TSOA™ STANDOFFS

Standoff "C" Dimension	Standoff Material	Test Sheet Material															
		.025" / 0.64 mm 5052-H34 Aluminum								.025" / 0.64 mm Cold-rolled Steel							
		Installation		Pushout		Torque-out <sup>(2)</sup>		Pull-thru <sup>(2)</sup>		Installation		Pushout		Torque-out <sup>(2)</sup>		Pull-thru <sup>(2)</sup>	
		(lbs.)	(kN)	(lbs.)	(N)	(in. lbs.)	(N-m)	(lbs.)	(N)	(lbs.)	(kN)	(lbs.)	(N)	(in. lbs.)	(N-m)	(lbs.)	(N)
.165" / 4.2 mm	Steel	700	3.1	70	311	6	0.68	230	1022	1100	4.9	100	445	9	1	206	916
	Stainless Steel	700	3.1	70	311	6	0.68	268	1191	1100	4.9	100	445	9	1	260	1155
	Aluminum	700	3.1	70	311	6	0.68	227	1009	—	—	—	—	—	—	—	—
.212" / 5.39 mm	Steel	700	3.1	90	400	11	1.24	264	1173	1800	8	150	667	15	1.7	207	920
	Stainless Steel	700	3.1	90	400	11	1.24	340	1511	1800	8	150	667	15	1.7	344	1529
	Aluminum	700	3.1	90	400	11	1.24	300	1333	—	—	—	—	—	—	—	—

### TSO4™ STANDOFFS

Standoff "C" Dimension	Test Sheet Material							
	.025" / 0.64 mm 300 series stainless steel							
	Installation		Pushout		Torque-out <sup>(2)</sup>		Pull-thru <sup>(2)</sup>	
	(lbs.)	(kN)	(lbs.)	(N)	(in. lbs.)	(N-m)	(lbs.)	(N)
.165" / 4.2 mm	6500	28.9	125	555	13	1.5	414	1840
.212" / 5.39 mm	6800	30.3	160	710	22	2.5	552	2453

### DSOS™/DSO™ STANDOFFS

UNIFIED	Thread Code	Max. Rec. Tightening Torque For Mating Screw (in. lbs.)	Test Sheet Material							
			.040" 5052-H34 Aluminum				.040" Cold-rolled Steel			
			Installation (lbs.)	Pushout (lbs.)	Torque-out (in. lbs.) <sup>(2)</sup>	Pull-thru (lbs.) <sup>(2)</sup>	Installation (lbs.)	Pushout (lbs.)	Torque-out (in. lbs.) <sup>(2)</sup>	Pull-thru (lbs.) <sup>(2)</sup>
			440	3.8	700	50	10	320	1100	75

METRIC	Thread Code	Max. Rec. Tightening Torque For Mating Screw (N-m)	Test Sheet Material							
			1 mm 5052-H34 Aluminum				1 mm Cold-rolled Steel			
			Installation (kN)	Pushout (N)	Torque-out (N-m) <sup>(2)</sup>	Pull-thru (N) <sup>(2)</sup>	Installation (kN)	Pushout (N)	Torque-out (N-m) <sup>(2)</sup>	Pull-thru (N) <sup>(2)</sup>
			M3	0.44	3.1	223	1.1	1422	4.9	334

### SOSG™/SOAG™ STANDOFFS

UNIFIED	Thread Code	Test Sheet Thickness and Test Sheet Material	Installation (lbs.)	Pushout (lbs.)	Torque-out (in. lbs.) <sup>(2)</sup>	Pull-thru (lbs.) <sup>(2)</sup>
	6440	.064" 5052-H34 Aluminum	1700	300	25	186
	8632	.064" 5052-H34 Aluminum	1700	400	45	248

METRIC	Thread Code	Test Sheet Thickness and Test Sheet Material	Installation (kN)	Pushout (N)	Torque-out (N-m) <sup>(2)</sup>	Pull-thru (N) <sup>(2)</sup>
		3.5M3	1.6 mm 5052-H34 Aluminum	7.6	1330	2.82

(1) Published installation forces are for general reference. Actual set-up and confirmation of complete installation should be made by observing proper seating of fastener as described in the installation steps. Other performance values reported are averages when all proper installation parameters and procedures are followed. Variations in mounting hole size, sheet material, and installation procedure may affect performance. Performance testing this product in your application is recommended. We will be happy to provide technical assistance and/or samples for this purpose.

(2) Joint failure in torque-out and pull-thru will depend on the strength and type of screw being used. In some cases the failure will be in the screw and not in the self-clinching standoff. Please contact our Applications Engineering group with any questions.



Get quote »

Angic Global Solutions

1-888-872-0690 [www.AngicGlobal.com](http://www.AngicGlobal.com) 226

<https://www.AngicGlobal.com> Sales@AngicGlobal.com

# SELF-CLINCHING STANDOFFS

If you require a standoff which we do not offer in this bulletin, please contact us. We will be happy to work with you to satisfy your special need. For other types of standard PEM® brand standoffs and spacers see:

## Bulletin CH



PEM® concealed-head standoffs.

## Bulletin K



PEM® broaching and surface mount standoffs for printed circuit boards.

## Bulletin SK



PEM® KEYHOLE® standoffs.

## Bulletin SSA



PEM® SNAP-TOP® standoffs.

## Bulletin MPF

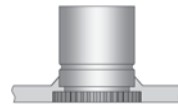

microPEM® standoffs.

**For more information on how to use PEM® self-clinching standoffs, see Tech Sheet “[PEM®-Ref/Standoff Basics](#)” on our web site.**

**PEM® “Single Groove”**  
(Registered trademark)  
*Parts that install into stainless steel sheets*

**PEM® “Two Groove”**  
(Registered trademark)

*Due to differences in manufacturing methods, location of grooves and surface appearance on barrel of actual parts may be different than shown in photo.*

## Thread Masking

PEM® PreTect™ thread masking plugs provide protection for PEM® internally threaded fasteners. They reduce labor and protect threads from paint and powder coating processes. Fasteners are shipped with plugs and film (where applicable) already in place. Plugs and film easily removed with a fine tip tool by end user. [Click here](#) for more information.



Fastener drawings and models are available at [www.pemnet.com](http://www.pemnet.com)



These PEM® fasteners install permanently;  
reduce hardware; and promote thinner and  
lighter designs in stainless applications.



**SS™**

## FASTENERS FOR USE IN STAINLESS STEEL SHEETS



Get quote »

Angic Global Solutions











1-888-872-0690

<https://www.AngicGlobal.com> [Sales@AngicGlobal.com](mailto:Sales@AngicGlobal.com)

# FASTENERS FOR USE IN STAINLESS STEEL SHEETS

One of the very basics of self-clinching is that the fastener must always be harder than the host sheet to ensure proper and permanent installation. This is particularly challenging when installing fasteners into stainless steel sheets. Therefore we have developed this line of specially hardened stainless steel fasteners for installation into stainless steel. **Refer to "Dos and Don'ts" on page 251 for further information.**

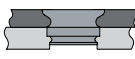
Fasteners made from precipitation hardened grade stainless including A286 stainless are particularly useful in applications such as outdoor equipment, medical devices and chemical and food processing equipment or anywhere corrosive element exposure is possible.

<p><b>SP™ PEM 300®</b> nuts provide <b>strong load-bearing internal threads</b> in stainless steel sheets as thin as .030"/0.8mm - <b>PAGE 230</b></p>		<p><b>FH4™ and FHP™</b> studs offer <b>externally threaded attachment points</b> in two stainless materials, depending on the level of corrosion resistance required. (See page 24 for other non-clinching stud solutions) - <b>PAGE 237</b></p>	
<p><b>SMPP™</b> nuts install into stainless steel sheets as thin as .025"/0.64mm. Reduced outer dimensions and thinner sheet capabilities compared to Type SP thread sizes - <b>PAGE 231</b></p>		<p><b>SGPC™ Swaging Collar Studs</b> can install into most panel material and accommodate multiple panels as long as the total thickness does not exceed the maximum sheet thickness - <b>PAGE 238</b></p>	
<p><b>A4™ and LA4™</b> internally threaded floating nuts allow for <b>mating hole misalignment and locking threads</b> if desired. - <b>PAGE 232</b></p>		<p><b>TP4™</b> pins provide an <b>unthreaded solution</b> for a wide range of positioning, pivot and alignment applications. - <b>PAGE 239</b></p>	
<p><b>F4™</b> fasteners are ideal for <b>flush applications</b> where a stainless steel sheet requires load-bearing threads - <b>PAGE 233</b></p>		<p><b>PFC4™</b> captive panel screws provides a tool only, <b>captive screw solution</b> for stainless steel sheets. (See page 24 for other non-clinching captive screw solutions) - <b>PAGE 240</b></p>	
<p><b>SO4™ and BSO4™</b> standoffs provide internally threaded fasteners for <b>stacking or spacing</b> applications - <b>PAGES 234 &amp; 235</b></p>		<p><b>SFP™ SpotFast®</b> fasteners provide a solution for <b>flush "face-on-face" sheet attachment</b> in stainless steel - <b>PAGE 241</b></p>	
<p><b>TSO4™</b> through hole threaded standoffs for <b>clinching into thinner sheets</b> than Type SO4. Install into sheets as thin as .025"/0.63mm. Also, threaded at the barrel end minimizing length of screw required - <b>PAGE 236</b></p>		<p><b>Material and finish specifications - PAGE 242</b></p> <p><b>Installation - PAGES 237 - 247</b></p> <p><b>Performance data - PAGES 248 - 250</b></p>	

For more information on these and other PEM® products, visit our PEMNET™ Resource Center at [www.pemnet.com](http://www.pemnet.com).

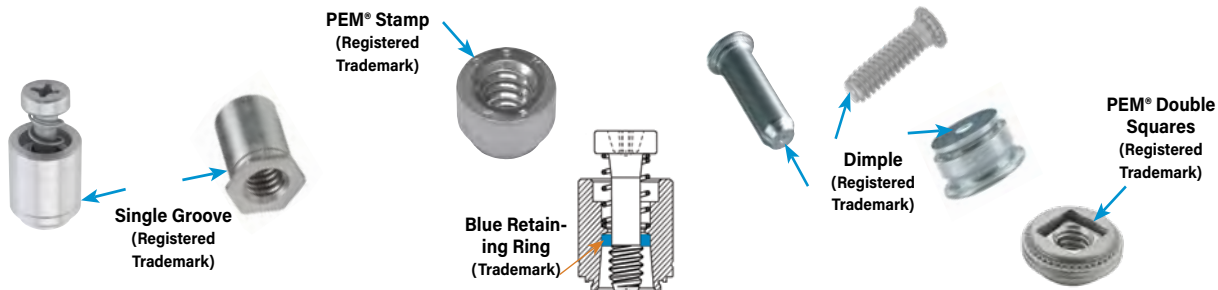

To be sure that you are getting genuine PEM® brand fasteners, look for the unique PEM® product markings and identifiers. On actual parts, location of groove on fastener may be different than shown in photo.

# FASTENERS FOR USE IN STAINLESS STEEL SHEETS

## SP™ PEM 300® SELF-CLINCHING NUTS

- After installation, reverse side of sheet remains flush and smooth.
- For use in stainless steel sheets HRB 90 / HB 192 or less.
- Corrosion resistance similar to 300 series stainless steel.

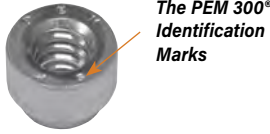

The PEM 300® Identification Marks

### PART NUMBER DESIGNATION

SP - 440 - 2  
 ↓            ↓            ↓  
 Type and Material    Thread Code    Shank Code

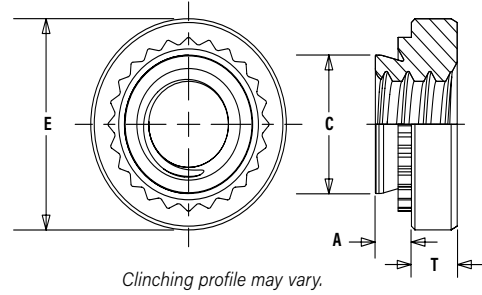

All dimensions are in inches.

Thread Size	Type	Thread Code	Shank Code	A (Shank) Max.	Rec. Min. Sheet Thickness	Hole Size In Sheet +.003 -.000	C Max.	E ±.010	T ±.010	Min. Dist. Hole To Edge
.086-56 (#2-56)	SP	256	0	.030	.030	.166	.165	.250	.070	.19
			1	.038	.040					
			2	.054	.056					
.112-40 (#4-40)	SP	440	0	.030	.030	.166	.165	.250	.070	.19
			1	.038	.040					
			2	.054	.056					
.138-32 (#6-32)	SP	632	0	.030	.030	.1875	.187	.280	.070	.22
			1	.038	.040					
			2	.054	.056					
.164-32 (#8-32)	SP	832	0	.030	.030	.213	.212	.310	.090	.27
			1	.038	.040					
			2	.054	.056					
.190-24 (#10-24)	SP	024	0	.030	.030	.250	.249	.340	.090	.28
			1	.038	.040					
			2	.054	.056					
.190-32 (#10-32)	SP	032	0	.030	.030	.250	.249	.340	.090	.28
			1	.038	.040					
			2	.054	.056					
.250-20 (1/4-20)	SP	0420	1	.054	.056	.344	.343	.440	.170	.34
			2	.087	.090					
.313-18 (5/16-18)	SP	0518	1	.054	.056	.413	.412	.500	.230	.38
			2	.087	.090					
.313-24 (5/16-24)	SP	0524	1	.054	.056	.413	.412	.500	.230	.38
			2	.087	.090					
.375-16 (3/8-16)	SP	0616	1	.087	.090	.500	.499	.560	.270	.44
			2	.120	.125					
.375-24 (3/8-24)	SP	0624	1	.087	.090	.500	.499	.560	.270	.44
			2	.120	.125					

All dimensions are in millimeters.

Thread Size x Pitch	Type	Thread Code	Shank Code	A (Shank) Max.	Rec. Min. Sheet Thickness	Hole Size In Sheet +0.08	C Max.	E ±0.25	T ±0.25	Min. Dist. Hole To Edge
METRIC										
M2 x 0.4	SP	M2	1	0.97	1	4.22	4.2	6.35	1.5	4.8
			2	1.38	1.4					
M2.5 x 0.45	SP	M2.5	0	0.77	0.8	4.22	4.2	6.35	1.5	4.8
			1	0.97	1					
			2	1.38	1.4					
M3 x 0.5	SP	M3	0	0.77	0.8	4.22	4.2	6.35	1.5	4.8
			1	0.97	1					
			2	1.38	1.4					
M4 x 0.7	SP	M4	0	0.77	0.8	5.41	5.38	7.87	2	6.9
			1	0.97	1					
			2	1.38	1.4					
M5 x 0.8	SP	M5	0	0.77	0.8	6.35	6.33	8.64	2	7.1
			1	0.97	1					
			2	1.38	1.4					
M6 x 1	SP	M6	1	1.38	1.4	8.75	8.73	11.18	4.08	8.6
			2	2.21	2.29					
M8 x 1.25	SP	M8	1	1.38	1.4	10.5	10.47	12.7	5.47	9.7
			2	2.21	2.29					
M10 x 1.5	SP	M10	1	2.21	2.29	14	13.97	17.35	7.48	13.5

The increased hardness of stainless steel panels requires careful consideration when installing self-clinching fasteners. Refer to "Dos and Don'ts" on page 251 for further information.

**NOTE:** Occasionally, users of our self-clinching fasteners encounter thread binding issues when assembling fasteners made from stainless steel. This problem is typically related to galling. Technical paper, [PEM® REF/THREAD GALLING](#), answers many of the typical questions that we receive surrounding this problem.



Get quote >>

Angic Global Solutions

1-888-872-0690 [t.com 230](#)

<https://www.AngicGlobal.com> Sales@AngicGlobal.com

# FASTENERS FOR USE IN STAINLESS STEEL SHEETS

## SMPP™ SELF-CLINCHING NUTS

- Installs into stainless steel sheets as thin as .025"/0.64mm.
- Corrosion resistance similar to 300 series stainless steel.
- Reduced outer dimensions and thinner sheet capabilities compared to SP nut thread sizes.
- Recommended for use in stainless steel sheets HRB 90 / HB 192 or less.



### PART NUMBER DESIGNATION

SMPP - 440

↓  
Type and  
Material

↓  
Thread  
Code

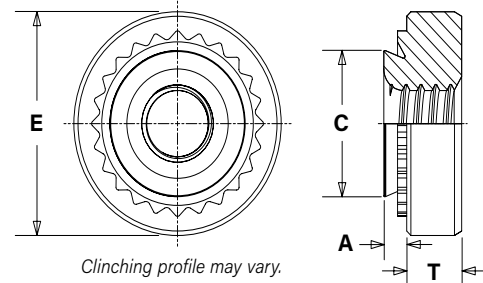

All dimensions are in inches.

UNIFIED	Thread Size	Type	Thread Code	A (Shank) Max.	Min. Sheet Thickness	Hole Size In Sheet +.003 -.000	C Max.	E ±.010	T ±.010	Min. Dist. Hole $\varnothing$ To Edge
	.086-56 (#2-56)	SMPP	256	.024	.025	.136	.135	.220	.065	.16
	.112-40 (#4-40)	SMPP	440	.024	.025	.166	.165	.220	.065	.20
	.138-32 (#6-32)	SMPP	632	.024	.025	.187	.186	.252	.065	.22

All dimensions are in millimeters.

METRIC	Thread Size x Pitch	Type	Thread Code	A (Shank) Max.	Min. Sheet Thickness	Hole Size In Sheet +0.08	C Max.	E ±0.25	T ±0.25	Min. Dist. Hole $\varnothing$ To Edge
	M2.5 x 0.45	SMPP	M2.5	0.61	0.64	3.8	3.79	5.6	1.4	3.9
	M3 x 0.5	SMPP	M3	0.61	0.64	4.24	4.22	5.6	1.4	5.1
	M3.5 x 0.6	SMPP	M3.5	0.61	0.64	4.75	4.73	6.4	1.4	5.5

**The increased hardness of stainless steel panels requires careful consideration when installing self-clinching fasteners. Refer to "Dos and Don'ts" on page 251 for further information.**

**NOTE:** Occasionally, users of our self-clinching fasteners encounter thread binding issues when assembling fasteners made from stainless steel. This problem is typically related to galling. Technical paper, [PEM® REF/THREAD GALLING](#), answers many of the typical questions that we receive surrounding this problem.

# FASTENERS FOR USE IN STAINLESS STEEL SHEETS

## A4™/LA4™ FLOATING SELF-CLINCHING FASTENERS

- Speeds assembly by compensating for mating hole misalignment.
- Permanent installation into stainless steel sheets as thin as .038"/0.97mm and greater.
- Provides high torque-out and pushout resistance in stainless panels.
- LA4 nut thread locking torque performance is equivalent to applicable NASM25027 specifications.<sup>(1)</sup>
- For use in stainless steel sheets HRB 88 / HB 183 or less.

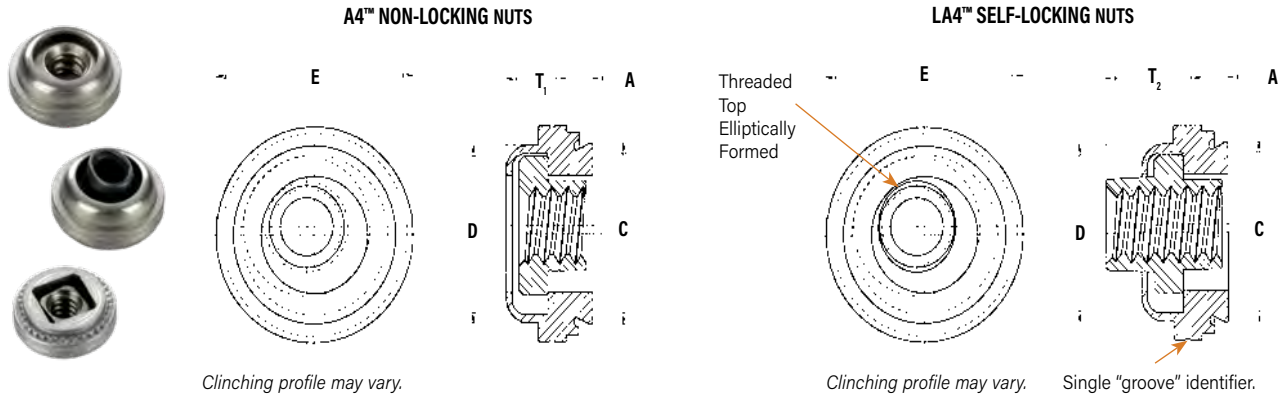

Float - .015"/0.38mm minimum, in all directions  
from center, .030"/0.76mm total.

### PART NUMBER DESIGNATION

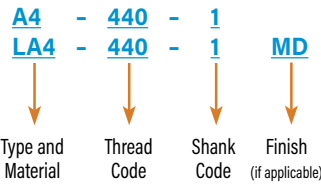

All dimensions are in inches.

UNIFIED	Thread Size	Type		Thread Code	Shank Code	A (Shank) Max.	Min. Sheet Thickness	Hole Size in Sheet +.003-.000	C Max.	D Max.	E ± .015	T <sub>1</sub> Max.	T <sub>2</sub> Max.	Min. Dist. Hole To Edge
		Non-Locking	Self-Locking											
	.112-40 (#4-40)	A4	LA4	440	1	.038	.038	.290	.289	.290	.360	.130	.190	.30
.138-32 (#6-32)	A4	LA4	632	1	.038	.038	.328	.327	.335	.390	.130	.200	.32	
.164-32 (#8-32)	A4	LA4	832	1	.038	.038	.368	.367	.365	.440	.130	.210	.34	
.190-32 (#10-32)	A4	LA4	032	1	.038	.038	.406	.405	.405	.470	.170	.270	.36	

All dimensions are in millimeters.

METRIC	Thread Size x Pitch	Type		Thread Code	Shank Code	A (Shank) Max.	Min. Sheet Thickness	Hole Size in Sheet + 0.08	C Max.	D Max.	E ± 0.38	T <sub>1</sub> Max.	T <sub>2</sub> Max.	Min. Dist. Hole To Edge
		Non-Locking	Self-Locking											
	M3 x 0.5	A4	LA4	M3	1	0.97	0.97	7.37	7.35	7.37	9.14	3.31	4.83	7.62
M4 x 0.7	A4	LA4	M4	1	0.97	0.97	9.35	9.33	9.28	11.18	3.31	5.34	8.64	
M5 x 0.8	A4	LA4	M5	1	0.97	0.97	10.31	10.29	10.29	11.94	4.32	6.86	9.14	

The increased hardness of stainless steel panels requires careful consideration when installing self-clinching fasteners. Refer to "Dos and Don'ts" on page 251 for further information.

(1) To meet national aerospace standards and to obtain testing documentation, product must be ordered to US NASM45938/11 specifications. Check our web site for a complete Military Specification and National Aerospace Standards Reference Guide (Bulletin NASM). Screws for use with PEM self-clinching locking fasteners should be Class 3A/4h fit or no smaller than Class 2A/6g.



Get quote >>

Angic Global Solutions

1-888-872-0690 [www.angic.com](http://www.angic.com) 232

<https://www.AngicGlobal.com> Sales@AngicGlobal.com

# FASTENERS FOR USE IN STAINLESS STEEL SHEETS

## F4™ PEMSERT® SELF-CLINCHING FLUSH FASTENERS

- Can be installed into sheets as thin as .060"/1.53mm.
- Ideal for flush applications where a stainless steel sheet requires load-bearing threads.
- Can be installed before bending and forming to provide strong threads while still remaining flat with no protrusions on either surface.
- For use in stainless steel sheets HRB 88 / HB 183 or less.



### PART NUMBER DESIGNATION

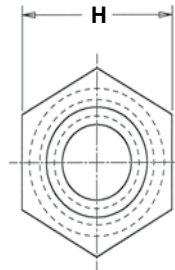
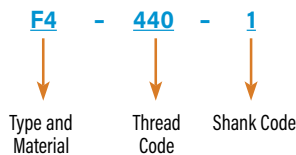

Profile for -1 shank code.

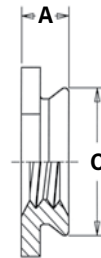

Profile for -2, -3, -4, & -5 shank codes.

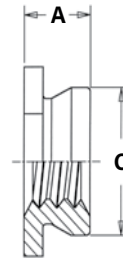

Clinching profile may vary.

All dimensions are in inches.

UNIFIED	Thread Size	Type	Thread Code	Shank Code	A (Shank) Max.	Sheet Thickness	Hole Size In Sheet +.003 -.000	C Max.	H Nom.	Min. Dist. Hole To Edge
	.086-56 (#2-56)	F4	256	1	.060	.060-.090	.172	.171	.188	.23
				2	.090	.091 Min.				
	.112-40 (#4-40)	F4	440	1	.060	.060-.090	.172	.171	.188	.23
				2	.090	.091 Min.				
	.138-32 (#6-32)	F4	632	1	.060	.060-.090	.213	.212	.250	.27
				2	.090	.091 Min.				
	.164-32 (#8-32)	F4	832	1	.060	.060-.090	.290	.289	.312	.28
				2	.090	.091 Min.				
	.190-32 (#10-32)	F4	032	1	.060	.060-.090	.312	.311	.343	.31
2				.090	.091 Min.					
.250-20 (1/4-20)	F4	0420	3	.120	.125-.155	.344	.343	.375	.34	
			4	.151	.156-.186					
			5	.182	.187 Min.					

All dimensions are in millimeters.

METRIC	Thread Size x Pitch	Type	Thread Code	Shank Code	A (Shank) Max.	Sheet Thickness	Hole Size In Sheet +0.08	C Max.	H Nom.	Min. Dist. Hole To Edge
	M2 x 0.4	F4	M2	1	1.53	1.53-2.3	4.37	4.35	4.8	6
				2	2.3	2.32 Min.				
	M2.5 x 0.45	F4	M2.5	1	1.53	1.53-2.3	4.37	4.35	4.8	6
				2	2.3	2.32 Min.				
	M3 x 0.5	F4	M3	1	1.53	1.53-2.3	4.37	4.35	4.8	6
				2	2.3	2.32 Min.				
	M4 x 0.7	F4	M4	1	1.53	1.53-2.3	7.37	7.35	7.9	7.2
				2	2.3	2.32 Min.				
	M5 x 0.8	F4	M5	1	1.53	1.53-2.3	7.92	7.9	8.7	8
2				2.3	2.32 Min.					
M6 x 1	F4	M6	3	3.05	3.18-3.94	8.74	8.72	9.5	8.8	
			4	3.84	3.96-4.72					
			5	4.63	4.75 Min.					

The increased hardness of stainless steel panels requires careful consideration when installing self-clinching fasteners. Refer to "Dos and Don'ts" on page 251 for further information.

# FASTENERS FOR USE IN STAINLESS STEEL SHEETS

## SO4™ THRU-HOLE THREADED STANDOFFS

- Ideal for stacking or spacing.
- Installed with head flush with one surface of the mounting sheet.
- For use in stainless steel sheets HRB 88 / HB 183 or less.

### GENERAL DIMENSIONAL DATA

All dimensions are in inches.

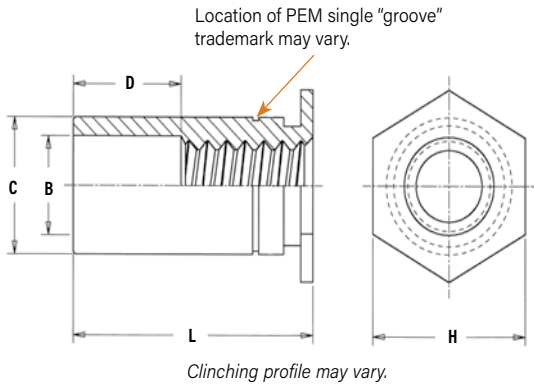

UNIFIED	Thread Code	Min. Sheet Thickness	Hole Size In Sheet +.003 -.000	B Counter-Bore Dia. ±.005	C +.000 -.005	H Nom.	Min. Dist. Hole $\varnothing$ To Edge	D $\pm$ .010
	440	.040	.166	.125	.165	.187	.23	Varies according to length. See length charts below.
	6440	.040	.213	.125	.212	.250	.27	
	632	.040	.213	.156	.212	.250	.27	
	8632	.050	.281	.156	.280	.312	.31	
	832	.050	.281	.188	.280	.312	.31	
032	.050	.281	.203	.280	.312	.31		

All dimensions are in millimeters.

METRIC	Thread Code	Min. Sheet Thickness	Hole Size In Sheet +0.08	B Counter-Bore Dia. ±0.13	C -0.13	H Nom.	Min. Dist. Hole $\varnothing$ To Edge	D $\pm$ 0.25
	M3	1	4.22	3.25	4.2	4.8	6	Varies according to length. See length charts below.
	3.5M3	1	5.41	3.25	5.39	6.4	6.8	
	M3.5	1	5.41	3.9	5.39	6.4	6.8	
	M4	1.27	7.14	4.8	7.12	7.9	8	
	M5	1.27	7.14	5.35	7.12	7.9	8	

### PART NUMBER DESIGNATION



**SO4 - 440 - 8**

SO4 → Type and Material  
440 → Thread Code  
8 → Length Code

### THREAD SIZE AND LENGTH SELECTION DATA

All dimensions are in inches.

UNIFIED	Thread Size	Type	Thread Code	Length "L" +.002 -.005 (Length Code in 32nds of an inch)															
				.125	.187	.250	.312	.375	.437	.500	.562	.625	.687	.750	.812	.875	.937	1.00	1.062
				.112-40 (#4-40)	S04	440 6440 <sup>(1)</sup>	4	6	8	10	12	14	16	18	20	22	24	—	—
.138-32 (#6-32)	S04	632 8632 <sup>(1)</sup>	4	6	8	10	12	14	16	18	20	22	24	26	28	30	32	34	
.164-32 (#8-32)	S04	832	4	6	8	10	12	14	16	18	20	22	24	26	28	30	32	34	
.190-32 (#10-32)	S04	032	4	6	8	10	12	14	16	18	20	22	24	26	28	30	32	34	
<b>D Dimension ±.010</b>			None				.187				.312				.437				

All dimensions are in millimeters.

METRIC	Thread Size x Pitch	Type	Thread Code	Length "L" +0.05 -0.13 (Length Code in millimeters)															
				3	4	6	8	10	12	14	16	18	—	—	—				
				M3 x 0.5	S04	M3 3.5M3 <sup>(1)</sup>	3	4	6	8	10	12	14	16	18	—	—	—	
M3.5 x 0.6	S04	M3.5	3	4	6	8	10	12	14	16	18	20	22	25					
M4 x 0.7	S04	M4	3	4	6	8	10	12	14	16	18	20	22	25					
M5 x 0.8	S04	M5	3	4	6	8	10	12	14	16	18	20	22	25					
<b>D Dimension ±0.25</b>			None				4				8				11				

(1) Standoffs with thread codes 6440, 8632, and 3.5M3 offer greater wall thickness for thread sizes 440, 632, and M3 respectively.

The increased hardness of stainless steel panels requires careful consideration when installing self-clinching fasteners. Refer to "Dos and Don'ts" on page 251 for further information.



Get quote >>

Angic Global Solutions

1-888-872-0690 [www.AngicGlobal.com](http://www.AngicGlobal.com) 234

<https://www.AngicGlobal.com> Sales@AngicGlobal.com

# FASTENERS FOR USE IN STAINLESS STEEL SHEETS

## BSO4™ BLIND THREADED STANDOFFS

- Ideal for stacking or spacing.
- Installed with closed end head flush with one surface of the mounting sheet.
- For use in stainless steel sheets HRB 88 / HB 183 or less.

### GENERAL DIMENSIONAL DATA

All dimensions are in inches.

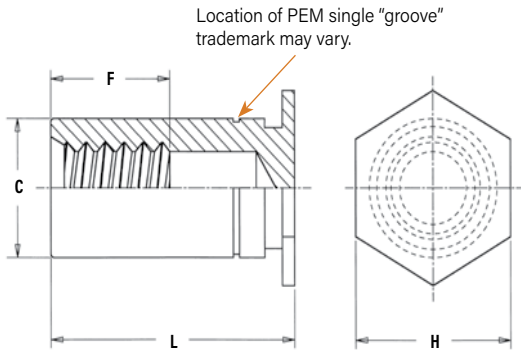

Clinching profile may vary.

UNIFIED	Thread Code	Min. Sheet Thickness	Hole Size In Sheet +.003 -.000	C +.000 -.005	H Nom.	Min. Dist. Hole $\phi$ To Edge	F Min.
	440	.040	.166	.165	.187	.23	Varies according to length. See length charts below.
	6440	.040	.213	.212	.250	.27	
	632	.040	.213	.212	.250	.27	
	8632	.050	.281	.280	.312	.31	
	832	.050	.281	.280	.312	.31	
032	.050	.281	.280	.312	.31		

All dimensions are in millimeters.

METRIC	Thread Code	Min. Sheet Thickness	Hole Size In Sheet +0.08	C -0.13	H Nom.	Min. Dist. Hole $\phi$ To Edge	F Min.
	M3	1	4.22	4.2	4.8	6	Varies according to length. See length charts below.
	3.5M3	1	5.41	5.39	6.4	6.8	
	M3.5	1	5.41	5.39	6.4	6.8	
	M4	1.27	7.14	7.12	7.9	8	
	M5	1.27	7.14	7.12	7.9	8	

### PART NUMBER DESIGNATION

**BSO4 - 440 - 8**



Type and Material      Thread Code      Length Code

### THREAD SIZE AND LENGTH SELECTION DATA

All dimensions are in inches.

UNIFIED	Thread Size	Type	Thread Code	Length "L" +.002 -.005 (Length Code in 32nds of an inch)												
				.312	.375	.437	.500	.562	.625	.687	.750	.812	.875	.937	1.00	1.062
.112-40 (#4-40)	BSO4	440	6440 <sup>(1)</sup>	10	12	14	16	18	20	22	24	26	28	30	32	34
			8632 <sup>(1)</sup>	10	12	14	16	18	20	22	24	26	28	30	32	34
.138-32 (#6-32)	BSO4	632	8632 <sup>(1)</sup>	10	12	14	16	18	20	22	24	26	28	30	32	34
			832	10	12	14	16	18	20	22	24	26	28	30	32	34
.164-32 (#8-32)	BSO4	832		10	12	14	16	18	20	22	24	26	28	30	32	34
.190-32 (#10-32)	BSO4	032		10	12	14	16	18	20	22	24	26	28	30	32	34
<b>F Dimension Min.</b>				.156		.187		.250			.375					

All dimensions are in millimeters.

METRIC	Thread Size x Pitch	Type	Thread Code	Length "L" +0.05 -0.13 (Length Code in millimeters)											
				6	8	10	12	14	16	18	20	22	25		
M3 x 0.5	BSO4	M3	3.5M3 <sup>(1)</sup>	6	8	10	12	14	16	18	20	22	25		
			M3.5	6	8	10	12	14	16	18	20	22	25		
M3.5 x 0.6	BSO4	M3.5		6	8	10	12	14	16	18	20	22	25		
M4 x 0.7	BSO4	M4		6	8	10	12	14	16	18	20	22	25		
M5 x 0.8	BSO4	M5		6	8	10	12	14	16	18	20	22	25		
<b>F Dimension Min.</b>				3.2	4	5	6.5	9.5							

(1) Standoffs with thread codes 6440, 8632, and 3.5M3 offer greater wall thickness for thread sizes 440, 632, and M3 respectively.

The increased hardness of stainless steel panels requires careful consideration when installing self-clinching fasteners. Refer to "Dos and Don'ts" on page 251 for further information.

# FASTENERS FOR USE IN STAINLESS STEEL SHEETS

## TSO4™ STANDOFFS FOR INSTALLATION INTO ULTRA-THIN STAINLESS STEEL SHEETS

- For installation into ultra-thin stainless steel sheets as thin as .025"/0.63mm.
- Threads on barrel end eliminate the need for long screws.
- For use in stainless steel sheets HRB 88 / HB 183 or less.

### GENERAL DIMENSIONAL DATA

All dimensions are in inches.

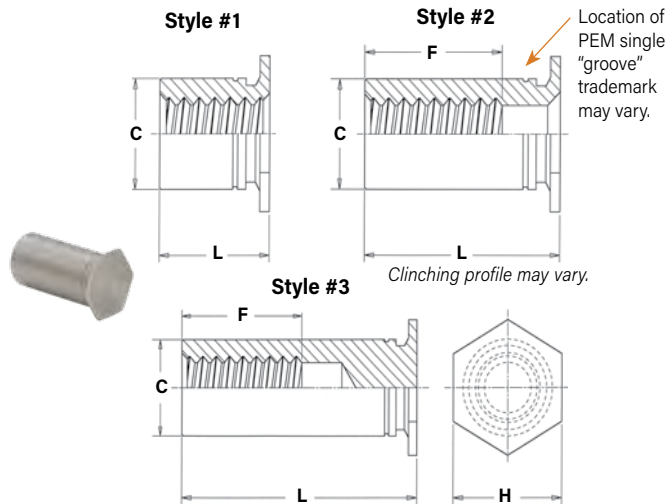

UNIFIED	Thread Code	Min. Sheet Thickness	Hole Size In Sheet +.003 -.000	C +.000 -.005	F Min. Thread Depth	H Nom.	Min. Dist. Hole To Edge
	256	.025	.166	.165	.200	.187	.23
6256	.025	.213	.212	.250		.27	
440	.025	.166	.165	.220	.187	.23	
6440	.025	.213	.212		.250	.27	
632	.025	.213	.212		.250	.27	

All dimensions are in millimeters.

METRIC	Thread Code	Min. Sheet Thickness	Hole Size In Sheet +0.08	C -0.13	F Min. Thread Depth	H Nom.	Min. Dist. Hole To Edge
	M25	0.63	4.22	4.2	5.2	4.8	5.8
6M25	0.63	5.41	5.39	6.4		7.1	
M3	0.63	4.22	4.2	6.2	4.8	5.8	
6M3	0.63	5.41	5.39		6.4	7.1	
M35	0.63	5.41	5.39		7	6.4	7.1

### THREAD SIZE AND LENGTH SELECTION DATA

All dimensions are in inches.

UNIFIED	Thread Size	Type	Thread Code	Length "L" ±.003											
				For other lengths / thread depth data see chart at bottom of page.											
				.090	.125	.187	.250	.312	.375	.437	.500	.562	.625	.687	.750
				Length Code (Length "L" without decimal point)											
.086-56 (#2-56)	TSO4	256	6256 <sup>(4)</sup>	090 <sup>(1)</sup>	125 <sup>(1)</sup>	187 <sup>(1)</sup>	250 <sup>(1)</sup>	312 <sup>(2)</sup>	375 <sup>(2)</sup>	437 <sup>(3)</sup>	500 <sup>(3)</sup>	562 <sup>(3)</sup>	625 <sup>(3)</sup>	687 <sup>(3)</sup>	750 <sup>(3)</sup>
				.112-40 (#4-40)	TSO4	440	6440 <sup>(4)</sup>	090 <sup>(1)</sup>	125 <sup>(1)</sup>	187 <sup>(1)</sup>	250 <sup>(1)</sup>	312 <sup>(2)</sup>	375 <sup>(2)</sup>	437 <sup>(2)</sup>	500 <sup>(3)</sup>
.138-32 (#6-32)	TSO4	632	-					125 <sup>(1)</sup>	187 <sup>(1)</sup>	250 <sup>(1)</sup>	312 <sup>(1)</sup>	375 <sup>(2)</sup>	437 <sup>(2)</sup>	500 <sup>(2)</sup>	562 <sup>(3)</sup>

All dimensions are in millimeters.

METRIC	Thread Size x Pitch	Type	Thread Code	Length "L" ±0.08										
				For other lengths / thread depth data see chart at bottom of page.										
				2.00	3.00	4.00	6.00	8.00	10.00	12.00	14.00	16.00	18.00	19.00
				Length Code (Length "L" without decimal point)										
M2.5 x 0.45	TSO4	M25	6M25 <sup>(4)</sup>	200 <sup>(1)</sup>	300 <sup>(1)</sup>	400 <sup>(1)</sup>	600 <sup>(1)</sup>	800 <sup>(2)</sup>	1000 <sup>(3)</sup>	1200 <sup>(3)</sup>	1400 <sup>(3)</sup>	1600 <sup>(3)</sup>	1800 <sup>(3)</sup>	1900 <sup>(3)</sup>
				M3 x 0.5	TSO4	M3	6M3 <sup>(4)</sup>	200 <sup>(1)</sup>	300 <sup>(1)</sup>	400 <sup>(1)</sup>	600 <sup>(1)</sup>	800 <sup>(2)</sup>	1000 <sup>(2)</sup>	1200 <sup>(3)</sup>
M3.5 x 0.6	TSO4	M35	-					300 <sup>(1)</sup>	400 <sup>(1)</sup>	600 <sup>(1)</sup>	800 <sup>(1)</sup>	1000 <sup>(2)</sup>	1200 <sup>(2)</sup>	1400 <sup>(3)</sup>

(1) Style #1. Thru-threaded.

(2) Style #2. Screw might not pass through unthreaded end. Tapped to minimum full thread depth shown. Incomplete threads on tap may allow screw to pass through.

(3) Style #3. Blind.

(4) Standoffs with thread codes 6256, 6440, 6M25 and 6M3 offer oversized body for increased bearing surface, wall thickness and performance.

Please contact your local PEM® distributor for availability, minimum quantity, and pricing information.

### LENGTH/STYLE DATA

All dimensions are in inches.

(Length can be specified in .001" increments.)

UNIFIED	Thread Code	Length "L" (Style #1)	Length "L" (Style #2)	Length "L" (Style #3)
	256	.090 - .250	.251 - .375	.376 - .750
6256	.090 - .280	.281 - .450	.451 - .750	
440	.120 - .350	.351 - .540	.541 - .750	
6440				

All dimensions are in millimeters.

(Length can be specified in .02 mm increments.)

METRIC	Thread Code	Length "L" (Style #1)	Length "L" (Style #2)	Length "L" (Style #3)
	M25	2.00 - 6.30	6.32 - 9.50	9.52 - 19.00
6M25				
M3	2.00 - 7.50	7.52 - 11.00	11.02 - 19.00	
6M3				
M35	3.00 - 8.80	8.82 - 12.80	12.82 - 19.00	

### PART NUMBER DESIGNATION

TSO4 - 440 - 250

↓                      ↓                      ↓  
Type and Material    Thread Code    Length Code

The increased hardness of stainless steel panels requires careful consideration when installing self-clinching fasteners. Refer to "Dos and Don'ts" on page 251 for further information.



Get quote >>

Angic Global Solutions

1-888-872-0690 [t.com](http://www.angic.com) 236

<https://www.AngicGlobal.com> Sales@AngicGlobal.com

# FASTENERS FOR USE IN STAINLESS STEEL SHEETS

## FH4™/FHP™ FLUSH-HEAD STUDS

- Permanent installation into stainless steel sheets as thin as .040"/1mm.
- FHP studs offers highest corrosion resistance and ideal for medical, food service, and marine applications.
- For use in stainless steel sheets HRB 92 / HB 202 or less.

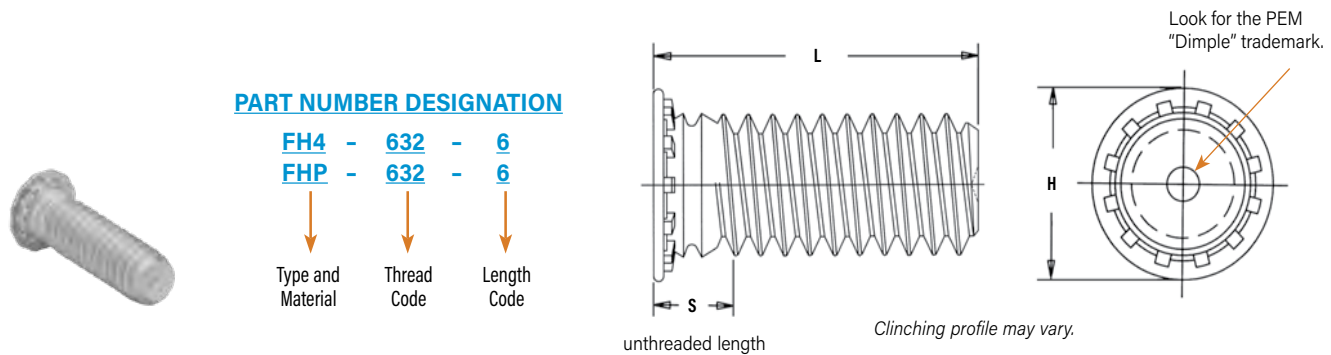

All dimensions are in inches.

UNIFIED	Thread Size	Type		Thread Code	Length Code "L" ±.015 (Length code in 16ths of an inch)									Sheet Thickness (1)	Hole Size in Sheet +.003 - .000	Max. Hole in Attach. Parts	H ±.015	S Max. (2)	Min. Dist. Hole to Edge	
					.250	.312	.375	.500	.625	.750	.875	1.00	1.25							1.50
	.112-40 (#4-40)	FH4	FHP	440	4	5	6	8	10	12	14	16	—	—	.040-.095	.111	.131	.176	.085	.219
	.138-32 (#6-32)	FH4	FHP	632	4	5	6	8	10	12	14	16	20	24	.040-.095	.137	.157	.206	.090	.250
	.164-32 (#8-32)	FH4	FHP	832	4	5	6	8	10	12	14	16	20	24	.040-.095	.163	.183	.237	.090	.281
	.190-32 (#10-32)	FH4	FHP	032	—	5	6	8	10	12	14	16	20	24	.040-.095	.189	.209	.256	.100	.281
	.250-20 (1/4-20)	FH4	—	0420	—	—	6	8	10	12	14	16	20	24	.062-.117	.249	.269	.337	.135	.312

All dimensions are in millimeters.

METRIC	Thread Size x Pitch	Type		Thread Code	Length Code "L" ±0.4 (Length Code in millimeters)									Sheet Thickness (1)	Hole Size in Sheet +0.08	Max. Hole in Attach. parts	H ±0.4	S Max. (2)	Min. Dist. Hole to Edge	
					6	8	10	12	15	18	20	25	30							35
	M3 x 0.5	FH4	FHP	M3	6	8	10	12	15	18	20	25	—	—	1 - 2.4	3	3.3	4.6	2.1	5.6
	M4 x 0.7	FH4	FHP	M4	6	8	10	12	15	18	20	25	30	35	1 - 2.4	4	4.7	5.9	2.4	7.2
	M5 x 0.8	FH4	FHP	M5	—	8	10	12	15	18	20	25	30	35	1 - 2.4	5	5.3	6.5	2.7	7.2
	M6 x 1	FH4	—	M6	—	—	10	12	15	18	20	25	30	35	1.6 - 3	6	6.8	8.2	3	7.9

(1) Performance may be reduced for studs installed into thicker sheets.

(2) Threads are gaugeable to within 2 pitches of the "S" Max. dimension. A class 3B/5H maximum material commercial nut shall pass up to the "S" Max. dimension.

**The increased hardness of stainless steel panels requires careful consideration when installing self-clinching fasteners. Refer to "Dos and Don'ts" on page 251 for further information.**

# FASTENERS FOR USE IN STAINLESS STEEL SHEETS

## SGPC™ SWAGING COLLAR STUDS

- Installs into sheets as thin as .024"/0.6mm.
- Can be used to attach dissimilar materials.
- Can accommodate multiple panels as long as the total thickness does not exceed the maximum sheet thickness.<sup>(1)</sup>
- Can be installed into most panel materials, including stainless steel.
- Allows for close centerline-to-edge distance.

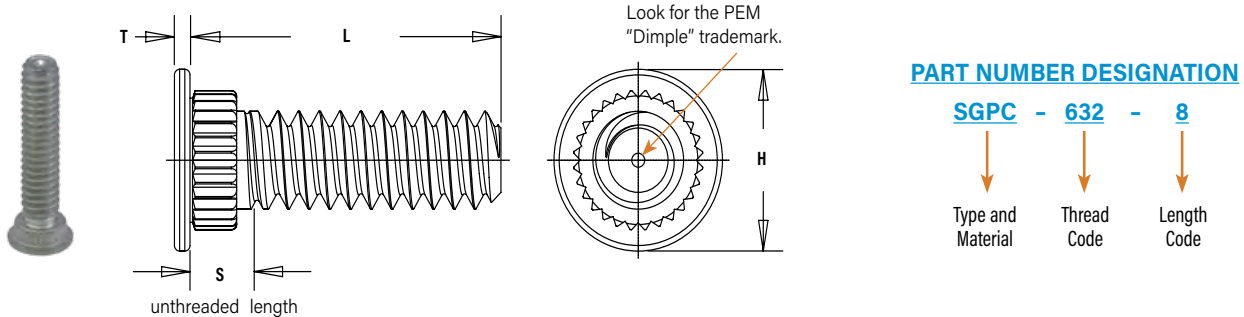

All dimensions are in inches.

UNIFIED	Thread Size	Type	Thread Code	Length Code "L" ±.015 (Length Code in 16ths of an inch)								Sheet Thickness (2)	Hole Size in Sheet +.003 -.000	Hole Dia. of Attached Panel +.005 -.000	H ±.010	S Max. (3)	T ±.004	Min. Dist. Hole to Edge	
		Fastener Material		.312	.375	.500	.625	.750	.875	1.00	1.25								1.50
		Stainless Steel																	
.086-56 (#2-56)	SGPC	256	5	6	8	10	12	—	—	—	—	.024 - .047	.145	.182	.189	.093	.020	.130	
.112-40 (#4-40)	SGPC	440	5	6	8	10	12	14	16	20	—	.024 - .047	.171	.205	.228	.101	.024	.160	
.138-32 (#6-32)	SGPC	632	5	6	8	10	12	14	16	20	24	.024 - .047	.196	.229	.256	.109	.024	.180	
.164-32 (#8-32)	SGPC	832	5	6	8	10	12	14	16	20	24	.024 - .047	.223	.259	.279	.109	.024	.200	
.190-32 (#10-32)	SGPC	032	5	6	8	10	12	14	16	20	24	.024 - .047	.249	.280	.307	.109	.024	.210	
.250-20 (1/4-20)	SGPC	0420	—	6	8	10	12	14	16	20	24	.024 - .047	.309	.343	.366	.131	.028	.250	

All dimensions are in millimeters.

METRIC	Thread Size x Pitch	Type	Thread Code	Length Code "L" ±0.4 (Length Code in millimeters)								Sheet Thickness (2)	Hole Size in Sheet +0.08	Hole Dia. of Attached Panel +0.13	H ±0.25	S Max. (3)	T ±0.1	Min. Dist. Hole to Edge	
		Fastener Material		8	10	12	15	18	—	—	—								—
		Stainless Steel																	
M2.5 x 0.45	SGPC	M2.5	8	10	12	15	18	—	—	—	—	0.6 - 1.2	4	4.95	5	2.4	0.5	3.9	
M3 x 0.5	SGPC	M3	8	10	12	15	18	20	25	—	—	0.6 - 1.2	4.5	5.45	6	2.5	0.6	4.3	
M4 x 0.7	SGPC	M4	8	10	12	15	18	20	25	30	—	0.6 - 1.2	5.5	6.3	7	2.7	0.6	4.9	
M5 x 0.8	SGPC	M5	8	10	12	15	18	20	25	30	35	0.6 - 1.2	6.5	7.45	8	2.8	0.6	5.5	
M6 x 1	SGPC	M6	—	10	12	15	18	20	25	30	35	0.6 - 1.2	7.5	8.3	9	3	0.7	6.2	

- When using the fastener to attach more than one sheet or panel, the stud may seem slightly loose after installation. This is a normal condition in some applications and will not affect the stud's performance.
- See installation data for tooling requirements. Contact Technical Support (techsupport@pemnet.com) for other thicknesses.
- Threads are gaugeable to within 2 pitches on the "S" Max. dimension. A class 3B/5H maximum material commercial nut shall pass up to the "S" Max. dimension.



Get quote >>

Angic Global Solutions

1-888-872-0690 [www.AngicGlobal.com](http://www.AngicGlobal.com) 238

<https://www.AngicGlobal.com> Sales@AngicGlobal.com

# FASTENERS FOR USE IN STAINLESS STEEL SHEETS

## TP4™ FLUSH-HEAD PINS

- Permanent installation into stainless steel sheets as thin as .040"/1mm.
- Satisfies a wide range of positioning, pivot, and alignment applications.
- Chamfered end makes mating hole location easy.
- For use in stainless steel sheets HRB 92 / HB 202 or less.

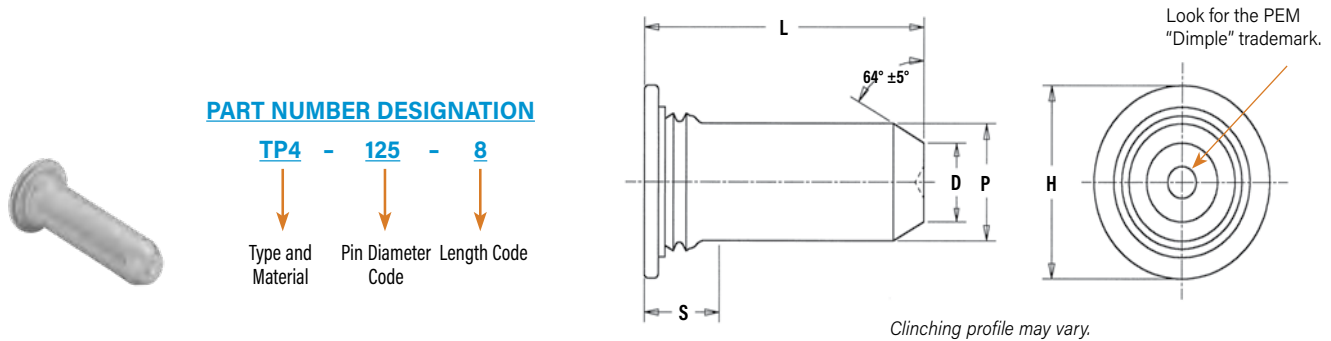

All dimensions are in inches.

UNIFIED	Pin Diameter P ±.002	Type	Pin Diameter Code	Length Code "L" ± .015 (Length Code in 16ths of an inch)					Min. Sheet Thickness	Hole Size in Sheet +.003 -.000	D ±.006	H ±.015	S Max. (1)	Min. Distance Hole to Edge
				.375	.500	.625	.750	1.00						
	.125	TP4	125	6	8	10	12	—	.040	.144	.090	.205	.090	.250
	.187	TP4	187	6	8	10	12	16	.040	.205	.132	.270	.090	.280
	.250	TP4	250	—	8	10	12	16	.040	.272	.177	.335	.090	.310

All dimensions are in millimeters.

METRIC	Pin Diameter P ±0.05	Type	Pin Diameter Code	Length Code "L" ± 0.4 (Length Code in millimeters)					Min. Sheet Thickness	Hole Size in Sheet +0.08	D ±0.15	H ±0.4	S Max. (1)	Min. Distance Hole to Edge
				8	10	12	16	—						
	3	TP4	3MM	8	10	12	16	—	1	3.5	2.05	5.2	2.29	6.4
	4	TP4	4MM	8	10	12	16	—	1	4.5	2.82	6.12	2.29	7.1
	5	TP4	5MM	—	10	12	16	20	1	5.5	3.53	7.19	2.29	7.6
	6	TP4	6MM	—	—	12	16	20	1	6.5	4.24	8.13	2.29	7.9

(1) Pin diameter may exceed max. in this region.

**The increased hardness of stainless steel panels requires careful consideration when installing self-clinching fasteners. Refer to "Dos and Don'ts" on page 251 for further information.**

# FASTENERS FOR USE IN STAINLESS STEEL SHEETS

## PFC4™ CAPTIVE PANEL SCREWS

- Tool only access meets UL 1950 "service area access" requirements and provides fixed screw solutions for the EC Machinery Directive.
- Assorted screw lengths for most applications.
- For use in stainless steel sheets HRB 88 / HB 183 or less.

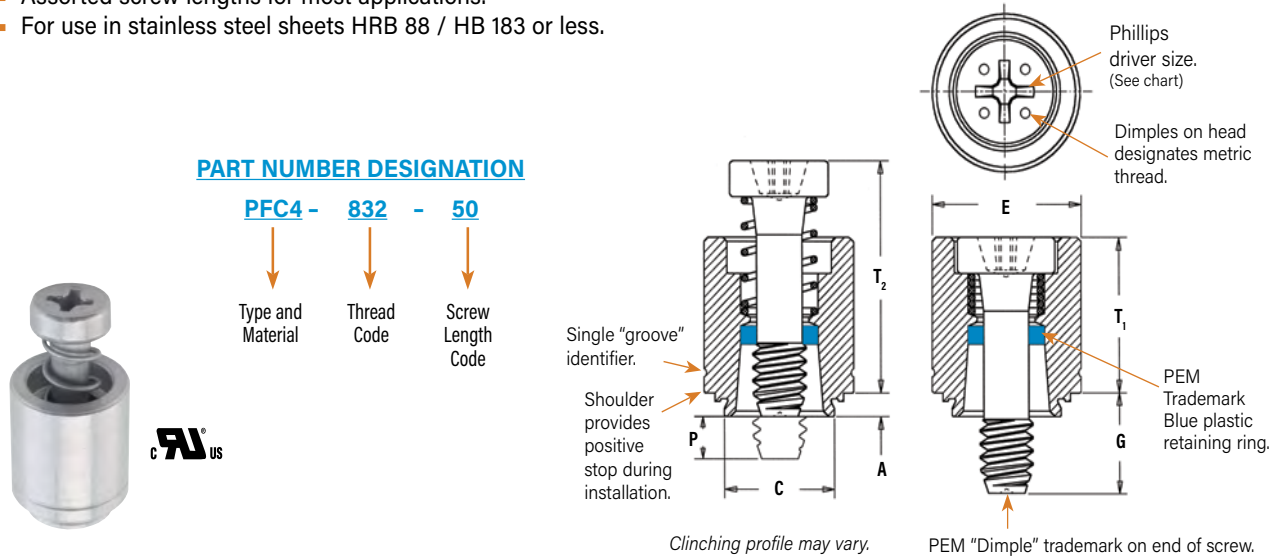

All dimensions are in inches.

UNIFIED	Thread Size	Type	Thread Code	Screw Length Code	A (Shank) Max.	Min. Sheet Thickness	Hole Size In Sheet +.003 - .000	C Max.	E ± .010	G ± .016	P ± .025	T <sub>1</sub> Max.	T <sub>2</sub> Nom.	Driver Size	Min. Dist. Hole To Edge
	.112-40 (#4-40)	PFC4	440	40	.060	.060	.265	.264	.344	.250 .375	.000 .125	.370	.540	#1	.25
.138-32 (#6-32)	PFC4	632	40	.060	.060	.281	.280	.375	.250	.000	.380	.540	#2	.28	
			62						.375	.125					
			84						.500	.250					
.164-32 (#8-32)	PFC4	832	50	.060	.060	.312	.311	.406	.312	.000	.480	.705	#2	.31	
			72						.437	.125					
			94						.562	.250					
.190-32 (#10-32)	PFC4	032	50	.060	.060	.344	.343	.437	.312	.000	.490	.705	#2	.34	
			72						.437	.125					
			94						.562	.250					

All dimensions are in millimeters.

METRIC	Thread Size x Pitch	Type	Thread Code	Screw Length Code	A (Shank) Max.	Min. Sheet Thickness	Hole Size In Sheet + 0.08	C Max.	E ± 0.25	G ± 0.4	P ± 0.64	T <sub>1</sub> Max.	T <sub>2</sub> Nom.	Driver Size	Min. Dist. Hole To Edge
	M3 x 0.5	PFC4	M3	40	1.53	1.53	6.73	6.71	8.74	6.4	0	9.4	13.72	#1	6.35
62				9.5						3.2					
M4 x 0.7	PFC4	M4	50	1.53	1.53	7.92	7.9	10.31	7.9	0	12.19	17.91	#2	7.87	
			72						11.1	3.2					
			94						14.3	6.4					
M5 x 0.8	PFC4	M5	50	1.53	1.53	8.74	8.72	11.1	7.9	0	12.45	17.91	#2	8.63	
			72						11.1	3.2					
			94						14.3	6.4					

The increased hardness of stainless steel panels requires careful consideration when installing self-clinching fasteners. Refer to "Dos and Don'ts" on page 251 for further information.



Get quote >>

Angic Global Solutions

1-888-872-0690 [www.angic.com](http://www.angic.com) 240

<https://www.AngicGlobal.com> Sales@AngicGlobal.com

# FASTENERS FOR USE IN STAINLESS STEEL SHEETS

## SFP™ SPOTFAST® FASTENERS

- Allows permanent joining of two metal sections.
- Offers high corrosion resistance.
- Can be used as single flush-mounted pivot point.
- Installs smooth with top sheet and flush or sub-flush with the bottom sheet.
- For use in sheets of HRB 88 / HB 183 or less.

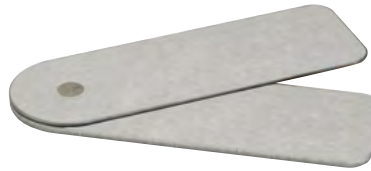

SpotFast® fastener used as a single flush-mounted pivot point. Top panel rotates about the SpotFast fastener.



Patented

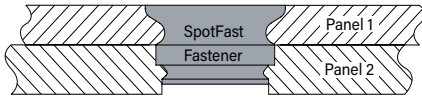

### PART NUMBER DESIGNATION

SFP - 3 - 1.0

Type and Material

Panel 1 Mounting Hole Code

Thickness Code

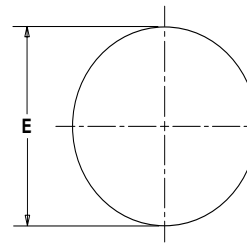

Clinching profile may vary.

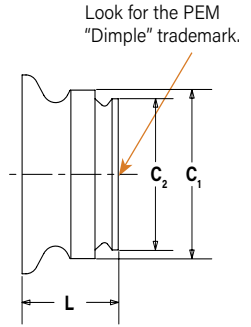

Look for the PEM "Dimple" trademark.

Type and Size	Thickness Code	Panel 1				Panel 2				C <sub>1</sub> Max.		C <sub>2</sub> Max.		E Max.		L Max.		Min. Dist. Hole To Edge	
		Thickness ±0.08 mm / ±.003"		Mounting Hole +0.08 mm / +.003" -0.000"		Thickness Min. (1)		Mounting Hole +0.08 mm / +.003" -0.000"											
		mm	in.	mm	in.	mm	in.	mm	in.	mm	in.	mm	in.	mm	in.	mm	in.	mm	in.
SFP-3	1.0	1	.039	3	.118	1	.039	2.5	.098	2.98	.117	2.48	.097	3.76	.148	1.9	.075	2.54	.1
SFP-3	1.2	1.2	.047	3	.118	1.2	.047	2.5	.098	2.98	.117	2.48	.097	3.76	.148	2.31	.091	2.54	.1
SFP-3	1.6	1.6	.063	3	.118	1.6	.063	2.5	.098	2.98	.117	2.48	.097	3.76	.148	3.12	.123	2.54	.1
SFP-5	1.0	1	.039	5	.197	1	.039	4.5	.177	4.98	.196	4.47	.176	5.56	.219	1.9	.075	3.6	.14
SFP-5	1.2	1.2	.047	5	.197	1.2	.047	4.5	.177	4.98	.196	4.47	.176	5.56	.219	2.31	.091	3.6	.14
SFP-5	1.6	1.6	.063	5	.197	1.6	.063	4.5	.177	4.98	.196	4.47	.176	5.56	.219	3.12	.123	3.6	.14

(1) Fastener will provide flush application at minimum sheet thickness.

**The increased hardness of stainless steel panels requires careful consideration when installing self-clinching fasteners. Refer to "Dos and Don'ts" on page 251 for further information.**

# FASTENERS FOR USE IN STAINLESS STEEL SHEETS

## MATERIAL AND FINISH SPECIFICATIONS

Type	Threads			Fastener Materials				Finish		For Use in Sheet Hardness <sup>(1)</sup>				Corrosion Resistance	Magnetic	
	Internal, ASME B1.1 2B/ ASME B1.13M, 6H	External, ASME B1.1 2A/ ASME B1.13M, 6g	Internal, UNJ Class 3B per ASME B1.15 / MJ Class 4H6H per ASME B1.2M (M6 thread 4H5H)	Precipitation Hardening Grade Stainless Steel	Heat-Treated 400 Series Stainless Steel	300 Series Stainless Steel	Age Hardened A286 Stainless Steel	Passivated and/or Tested per ASTM A380	Black Dry-film Lubricant	HRB 92 / HB 202 or less	HRB 90 / HB 192 or less	HRB 88 / HB 183 or less	Any Sheet Hardness			
SP	▪						▪	▪			▪			Excellent	No	
SMPP	▪						▪	▪			▪			Excellent	No	
A4	▪				▪ (retainer)	▪ (insert)		▪				▪		Fair	Yes	
LA4			▪		▪ (retainer)	▪ (insert)		▪ (retainer)	▪ (insert)			▪		Fair	Yes	
F4	▪				▪			▪				▪		Fair	Yes	
SO4	▪				▪			▪				▪ <sup>(2)</sup>		Fair	Yes	
BSO4	▪				▪			▪				▪ <sup>(2)</sup>		Fair	Yes	
TSO4	▪				▪			▪				▪ <sup>(2)</sup>		Fair	Yes	
FH4		▪			▪			▪		▪				Fair	Yes	
FHP		▪					▪	▪		▪				Excellent	No	
SGPC		▪				▪		▪					▪	Excellent	No	
TP4	Not threaded				▪			▪		▪				Fair	Yes	
PFC4 (Retainer) (Screw) (Spring)					▪			▪				▪		Fair	Yes	
		▪			▪			▪								
SFP	Not threaded			▪				▪				▪		Excellent	Yes	
Part number codes for finishes								None	MD							

(1) HRB - Hardness Rockwell "B" Scale. HB - Hardness Brinell.

(2) Also available, standoffs for installation into thinner, high strength, HSLA steel. See Innovation Brief "[Standoffs For Hard Panels](#)" on our website.

### A NOTE ABOUT 400 SERIES FASTENERS FOR STAINLESS STEEL PANELS

In order for self-clinching fasteners to work properly, the fastener must be harder than the sheet into which it is being installed. In the case of stainless steel panels, fasteners made from 300 Series Stainless Steel do not meet this hardness criteria. It is for this reason that 400 series fasteners are offered (A4, LA4, F4, SO4, BSO4, TSO4, FH4, TP4, and PFC4 fasteners). However, while these 400 Series fasteners install and perform well in 300 Series stainless sheets they should not be used if the end product:

- Will be exposed to any appreciable corrosive presence.
- Requires non-magnetic fasteners.
- Will be exposed to any temperatures above 300°F (149°C)

If any of these are issues, please contact [techsupport@pemnet.com](mailto:techsupport@pemnet.com) for other options.



Get quote »

Angic Global Solutions

1-888-872-0690 [www.angic.com](http://www.angic.com) 242

<https://www.AngicGlobal.com> Sales@AngicGlobal.com

# FASTENERS FOR USE IN STAINLESS STEEL SHEETS

## INSTALLATION

### SP™/SMPP™ NUTS<sup>(1)</sup>

1. Prepare properly sized mounting hole in sheet. Do not perform any secondary operations such as deburring.
2. Place fastener into the recommended counterbore anvil hole and place the mounting hole (punch side) over the shank of the fastener as shown in diagram.
3. With installation punch and anvil surfaces parallel, apply squeezing force until the head of the nut comes into contact with the sheet material.

### PEMSERTER® Installation Tooling

#### SP NUTS

UNIFIED	Thread Code	Anvil Dimensions (in.)				Anvil Part Number	Punch Part Number
		A	P +.000	R	R <sub>i</sub>		
		±.002	-.001	Max.	+.005		
440	.255	.064	.010	.005	8012821	975200048	
632	.286	.064	.010	.005	8012822		
832	.317	.082	.010	.005	8012823		
024/032	.348	.082	.010	.005	8012824	8003076	
0420	.443	.163	.010	.005	8012825		
0518	.505	.230	.010	.005	8015359		
0616/0624	.570	.263	.010	.005	8015863		

METRIC	Thread Code	Anvil Dimensions (mm)				Anvil Part Number	Punch Part Number
		A	P	R	R <sub>i</sub>		
		±0.05	-0.03	Max.	+0.13		
M2	6.48	1.63	0.25	0.13	8012821	975200048	
M2.5-0	6.48	1.42	0.25	0.13	8019477		
M2.5-1,-2	6.48	1.63	0.25	0.13	8012821		
M3	6.48	1.63	0.25	0.13	8012821		
M3.5	7.26	1.63	0.25	0.13	8012822		
M4	8.05	2.08	0.25	0.13	8012823		
M5	8.84	2.08	0.25	0.13	8012824		
M6	11.25	4.14	0.25	0.13	8012825	8003076	
M8	12.83	5.41	0.25	0.13	8015360		
M10	17.58	7.47	0.25	0.13	8015886		

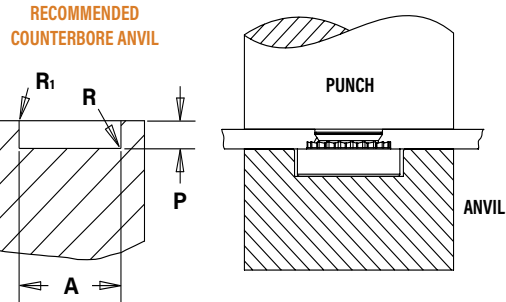

#### SMPP NUTS

UNIFIED	Thread Code	Anvil Dimensions (in.)				Anvil Part Number	Punch Part Number
		A	P +.000	R	R <sub>i</sub>		
		±.002	-.001	Max.	+.005		
256	.223	.060	.010	.005	8020023	975200048	
440	.233	.060	.010	.005	8021386		
632	.255	.060	.010	.005	8020024		

METRIC	Thread Code	Anvil Dimensions (mm)				Anvil Part Number	Punch Part Number
		A	P	R	R <sub>i</sub>		
		±0.05	-0.03	Max.	+0.13		
M2.5	5.66	1.27	0.25	0.13	8020025	975200048	
M3	5.66	1.27	0.25	0.13	8021474		
M3.5	6.48	1.27	0.25	0.13	8020026		

(1) For best results, we recommend using the installation punch and anvil shown. Deviations from recommended installation tooling may result in sheet distortion and reduced performance.

**NOTE:** Variations in hole preparation, installation tooling, installation force, and sheet material type, thickness, and hardness will affect both performance and tooling life.

### A4™/LA4™ NUTS

1. Prepare properly sized mounting hole in sheet. Do not perform any secondary operations such as deburring.
2. Place fastener into the anvil hole and place the mounting hole (punch side) over the shank of the fastener.
3. With installation punch and anvil surfaces parallel, apply sufficient squeezing force until the flange contacts the sheet material.

### PEMSERTER® Installation Tooling

Thread Code	Anvil Part Number	Punch Part Number
440/M3	8013889	975200048
632	8013890	
832/M4	8013891	
032/M5	8013892	

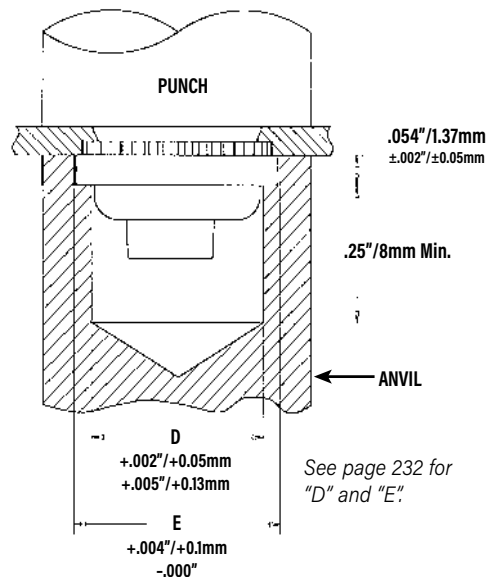

## INSTALLATION

### F4™ NUTS

1. Prepare properly sized round mounting hole in sheet. Do not perform any secondary operations such as deburring.
2. Place shank of fastener into mounting hole (punch side) as show in the drawing.
3. With installation punch and anvil surfaces parallel, apply sufficient squeezing force only to embed hexagonal head flush in sheet. The metal displaced by the head flows evenly and smoothly around the back-tapered shank of the fastener, securely locking it into place with high pullout resistance while at the same time, the embedded hexagonal head provides high torque resistance.

#### PEMSERTER® Installation Tooling

Thread Code	Anvil Part Number	Punch Part Number
256/M2/M2.5	8006193	975200048
440/M3	975200040	
632	975200041	
832/M4	975200042	
1032/M5	975200043	
0420/M6	975200044	

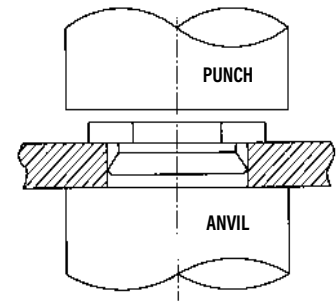

### SO4™/BSO4™ STANDOFFS

1. Prepare properly sized round mounting hole in sheet. Do not perform any secondary operations such as deburring.
2. Insert standoff barrel through mounting hole (punch side) in sheet and into anvil as shown.
3. With installation punch and anvil surfaces parallel, apply only enough squeezing force to embed the standoff's head flush in the sheet.

#### PEMSERTER® Installation Tooling

Thread Code	Anvil Part Number	Punch Part Number
440/M3	970200487300	975200048
632/6440/M3.5/3.5M3	970200012300	
832/8632/M4	970200013300	
032/M5	970200013300	

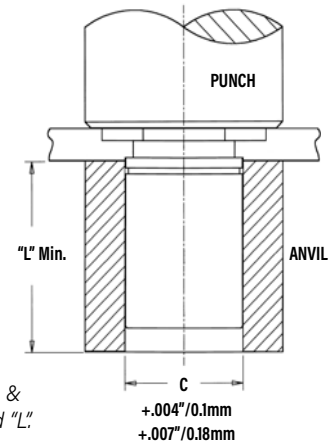

See pages 234 & 235 for "C" and "L".

+0.004"/0.1mm  
+0.007"/0.18mm

### TSO4™ STANDOFFS

1. Prepare properly sized mounting hole in sheet. Do not perform any secondary operation such as deburring.
2. Insert standoff through mounting hole (punch side) of sheet and into anvil as shown in drawing.
3. With installation punch and anvil surfaces parallel, apply only enough squeezing force to embed the standoff's head flush in the sheet. Drawing at right shows required installation anvil for sheet thickness of .025" to .032"/0.63 to 0.81mm. A chamfered anvil is not required for sheets over .032"/0.81mm.

#### PEMSERTER® Installation Tooling

UNIFIED	Thread Code	Anvil Dimensions (in.) For Sheets Below .032"		Anvil Part No. For Sheets Over .032"	Punch Part Number
		B	Anvil Part No.		
	256/440	.187 - .194	8003291	970200487300	975200048
	6256/6440/632	.250 - .257	8003292	970200012300	975200048

METRIC	Thread Code	Anvil Dimensions (mm) For Sheets Below 0.63 mm		Anvil Part No. For Sheets Over 0.63 mm	Punch Part Number
		B	Anvil Part No.		
	M2.5/M3	4.75 - 4.93	8003291	970200487300	975200048
	6M25/6M3/M35	6.35 - 6.53	8003292	970200012300	975200048

#### REQUIRED INSTALLATION ANVIL FOR SHEETS BELOW .032"/0.81MM

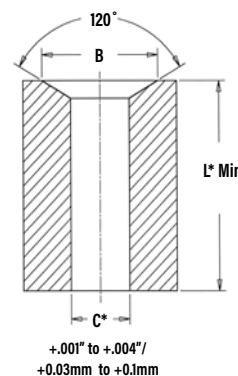

+0.001" to +0.004"/  
+0.03mm to +0.1mm

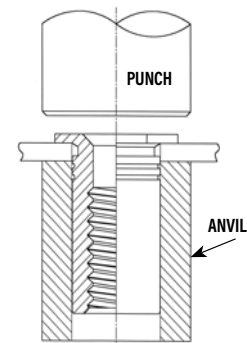

\*See page 236 for "C" and "L".



Get quote »

Angic Global Solutions

1-888-872-0690 [www.AngicGlobal.com](http://www.AngicGlobal.com) 244

<https://www.AngicGlobal.com> Sales@AngicGlobal.com

# FASTENERS FOR USE IN STAINLESS STEEL SHEETS

## INSTALLATION

### FH4™/FHP™ STUDS

1. Prepare properly sized mounting hole in sheet. Do not perform any secondary operations such as deburring.
2. Insert stud through mounting hole (punch side) of sheet and into anvil hole.
3. With punch and anvil surfaces parallel, apply squeezing force to embed the head of the stud flush in the sheet.

For FH4/FHP studs, a special anvil with a raised ring is required to create a proper installation. The raised ring acts as a second displacer of the stainless sheet material, thereby ensuring that the annular groove is filled. Please see page 10 for recommended sheet thickness range. The special anvils are available from PEM stock or can be machined from suitable tool steel. A hardness of HRC 55 / HB 547 minimum is required to provide long anvil life. We recommend measuring the "P" dimension every 5000 installations to ensure that the anvil remains within specification.

### PEMSERTER® Installation Tooling

UNIFIED	Thread Code	Anvil Dimensions (in.)						Anvil Part Number	Punch Part Number
		A	B	C	P	R <sub>1</sub>	R <sub>2</sub>		
	+0.003 -0.000	±.002	±.002	±.001	Max.	Max.			
	440	.113	.144	.174	.010	.003	.005	8001645	975200048
	632	.140	.170	.200	.010	.003	.005	8001644	
	832	.166	.202	.236	.010	.003	.005	8001643	
	032	.191	.235	.275	.010	.003	.005	8001642	
	0420	.252	.324	.360	.020	.003	.005	8002535	

METRIC	Thread Code	Anvil Dimensions (mm)						Anvil Part Number	Punch Part Number
		A	B	C	P	R <sub>1</sub>	R <sub>2</sub>		
	+0.08	±0.05	±0.05	±.025	Max.	Max.			
	M3	3.05	3.81	4.57	0.25	0.08	0.13	8001678	975200048
	M4	4.04	4.95	5.82	0.25	0.08	0.13	8001677	
	M5	5.08	6.15	7.16	0.25	0.08	0.13	8001676	
	M6	6.05	7.87	8.79	0.51	0.08	0.13	8002536	

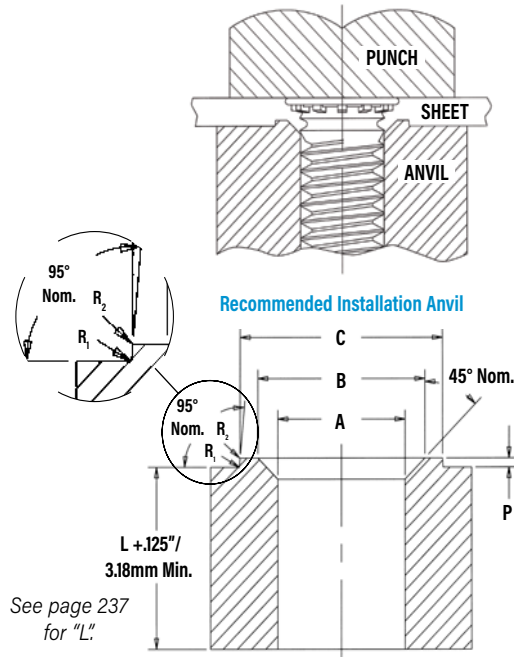

# FASTENERS FOR USE IN STAINLESS STEEL SHEETS

## INSTALLATION

### SGPC™ STUDS

1. Prepare properly sized mounting hole in sheet.
2. Insert fastener through mounting hole (punch side) as shown in drawing.
3. With installation punch and anvil surfaces parallel, apply squeezing force until the punch pushes over the protruding knurls of the stud.

### PEMSERTER® Installation Tooling

UNIFIED	Thread Code	Punch Dimensions (in.)		Punch Part Number	Anvil Dimensions (in.)		Anvil Part Number
		A	B		C	P	
		+0.004 -0.000	+0.000 -0.001		+0.001	+0.000 -0.002	
	256	.209	.019	8015111	.087	.014	8016983
	440	.248	.022	8015112	.113	.014	8016984
	632	.276	.022	8015113	.139	.014	8016985
	832	.299	.022	8015114	.165	.014	8016986
	032	.327	.022	8015115	.191	.014	8016987
	0420	.386	.026	8015116	.251	.014	8016988

METRIC	Thread Code	Punch Dimensions (mm)		Punch Part Number	Anvil Dimensions (mm)		Anvil Part Number
		A	B		C	P	
		+0.1	-0.025		+0.025	-0.05	
	M2.5	5.5	0.47	8015117	2.53	0.35	8016989
	M3	6.5	0.57	8015118	3.03	0.35	8016990
	M4	7.5	0.57	8015119	4.03	0.35	8016991
	M5	8.5	0.57	8015120	5.03	0.35	8016992
	M6	9.5	0.67	8015121	6.03	0.35	8016993

**NOTE:** For panel design information, go to [http://www.pemnet.com/SGPC\\_Panel\\_Designs.pdf](http://www.pemnet.com/SGPC_Panel_Designs.pdf)

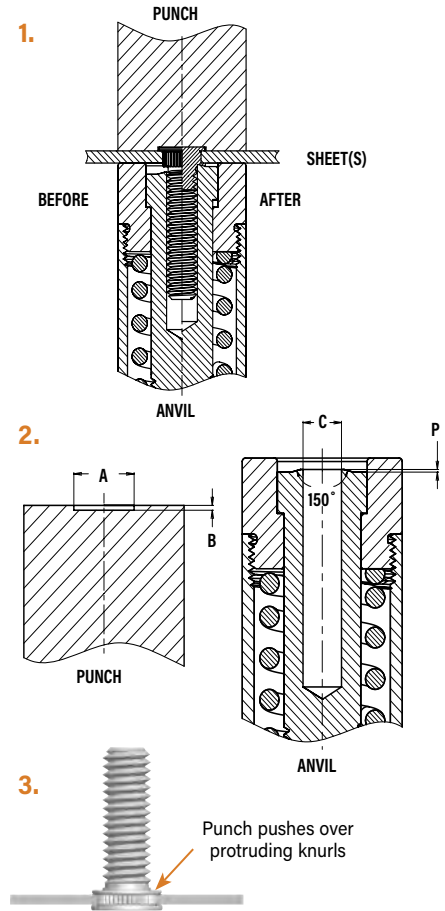

### TP4™ PINS

1. Prepare properly sized mounting hole in sheet. Do not perform any secondary operations such as deburring.
2. Place pin end through mounting hole in sheet (punch side) and into anvil as shown.
3. With installation punch and anvil surfaces parallel, apply squeezing force to embed the pin's head flush in the sheet.

### PEMSERTER® Installation Tooling

UNIFIED	Pin Dia. Code	Test Sheet Thickness (in.)	Anvil Dimensions (in.)		Anvil Part Number	Punch Part Number
			A ±.002	C ±.002		
			125	.040 - .060 Over .060 (1)		
187	.040 - .065 Over .065 (1)	.220 .192	8003285 8003279			
250	.040 - .075 Over .075 (1)	.285 .255	8003286 8003280			

METRIC	Pin Dia. Code	Test Sheet Thickness (mm)	Anvil Dimensions (mm)		Anvil Part Number	Punch Part Number
			A ±0.05	C ±0.05		
			3MM	1 - 1.7 Over 1.7 (1)		
4MM	1 - 1.7 Over 1.7 (1)	4.88 4.11	8003287 8003281			
5MM	1 - 1.8 Over 1.8 (1)	5.89 5.13	8003288 8003282			
6MM	1 - 1.9 Over 1.9 (1)	6.89 6.12	8003289 8003283			

(1) Chamfered anvil not required.

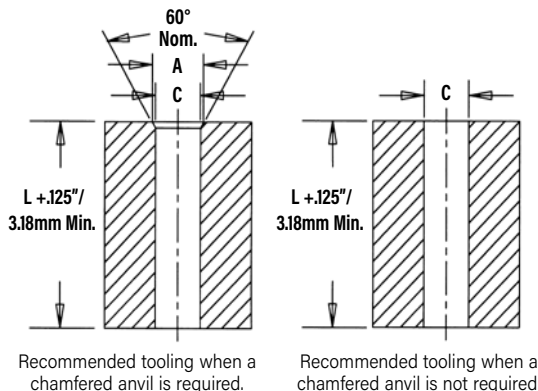

See page 239 for "L."

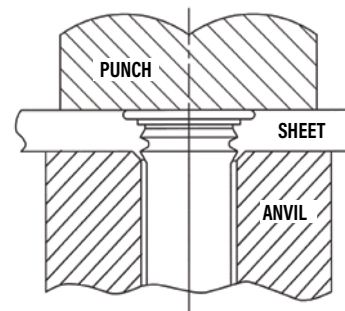

Get quote >>

Angic Global Solutions

1-888-872-0690 [www.angic.com](http://www.angic.com) 246

[www.AngicGlobal.com](http://www.AngicGlobal.com) Sales@AngicGlobal.com

## INSTALLATION

### PFC4™ CAPTIVE PANEL SCREWS

1. Prepare properly sized mounting hole in sheet. Do not perform any secondary operations such as deburring.
2. Place fastener into the anvil hole and place the mounting hole (punch side) over the shank of the fastener retainer.
3. With installation punch and anvil surfaces parallel, apply squeezing force until the shoulder of the retainer comes in contact with the sheet material.

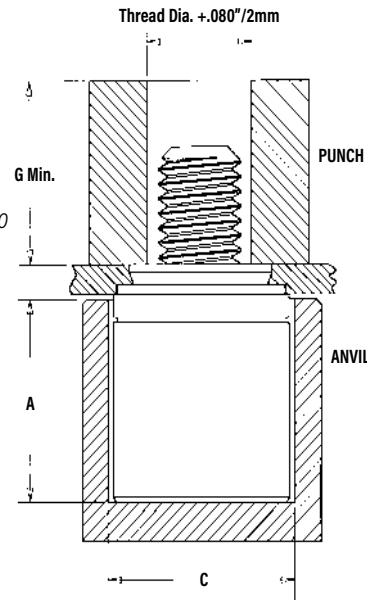

### PEMSERTER® Installation Tooling

UNIFIED	Thread Code	Anvil Dimensions (in.)		Anvil Part Number	Punch Part Number
		A ±.002	C ±.002		
	440	.345	.358	975200027	975200060
632	.345	.390	975201243	975200061	
832	.435	.421	975200029	975200062	
032	.435	.452	975201244	975200064	

METRIC	Thread Code	Anvil Dimensions (mm)		Anvil Part Number	Punch Part Number
		A ±0.05	C ±0.05		
	M3	8.76	9.09	975200027	975200060
M4	11.05	10.69	975200029	975200062	
M5	11.05	11.48	975201244	975200064	

### SFP™ FASTENERS

1. Prepare properly sized mounting hole in both panels. Do not perform any secondary operations such as deburring.
2. Place Panel 2 with smaller mounting hole on anvil and align Panel 1 mounting hole with the mounting hole of Panel 2. Place the smaller diameter end of the fastener through the mounting holes as shown in the drawing to the right.
3. With installation punch and anvil surfaces parallel, apply squeezing force until the fastener is flush with the top of Panel 1.

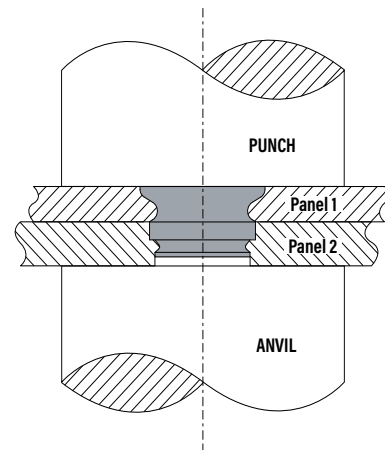

**NOTE:** To use as a flush-mounted pivot point, for best results, install SpotFast® fastener into Panel 1 first, then place Panel 2 over fastener and squeeze again.

### PEMSERTER® Installation Tooling

Size	Anvil Part Number	Punch Part Number
SF-3 / SF-5	975200046	975200048

#### INSTALLATION NOTES

- For best results we recommend using a Haeger® or PEMSERTER® machine for installation of PEM® self-clinching fasteners. Please check our website for more information.
- Visit the Animation Library on our website to view the installation process [for select products](#).

# FASTENERS FOR USE IN STAINLESS STEEL SHEETS

## PERFORMANCE DATA<sup>(1)</sup>

### SP™ NUTS

UNIFIED	Type	Thread Code	Shank Code	Test Sheet Material	Installation (lbs.)	Pushout (lbs.)	Torque-out (in. lbs.)
	SP	256		0	304 Stainless Steel	8000	130
1				9000		165	17
2				10000		290	18
SP	440		0	304 Stainless Steel	8000	130	14
			1		9000	165	17
			2		10000	290	18
SP	632		0	304 Stainless Steel	8500	140	18
			1		9500	170	24
			2		10500	340	28
SP	832		0	304 Stainless Steel	9000	145	30
			1		10000	180	37
			2		11000	360	45
SP	024/032		0	304 Stainless Steel	9500	180	35
			1		10500	230	45
			2		11500	400	60
SP	0420		1	304 Stainless Steel	13500	450	150
			2		13500	600	170
SP	0518		1	304 Stainless Steel	14800	470	170
			2		14800	750	250
SP	0524		1	304 Stainless Steel	14800	470	170
			2		14800	750	250
SP	0616/0624		1	304 Stainless Steel	16000	600	300
			2		20000	700	370

METRIC	Thread Code	Shank Code	Test Sheet Material		
			304 Stainless Steel		
			Installation (kN)	Pushout (N)	Torque-out (N-m)
M2		1	40	725	1.92
		2	44.5	1290	2.03
M2.5		0	35.6	575	1.58
		1	40	725	1.92
M3		2	44.5	1290	2.03
		0	35.6	575	1.58
M4		1	40	725	1.92
		2	44.5	1290	2.03
M5		0	40	645	3.38
		1	44.5	800	4.18
M6		2	49	1600	5.08
		0	42.3	800	3.95
M8		1	46.7	1025	5.08
		2	51.2	1775	6.77
M10		1	60	2000	17
		2	60	2600	19
M10		1	66	2100	19
		2	80	4500	23
M10		1	80	2150	38

### SMPP™ NUTS

UNIFIED	Thread Code	Max. Nut Tightening Torque (in. lbs.) (2) (3)	Test Sheet Thickness and Material (in.)	Sheet Hardness HRB	Installation (lbs.) (4)	Pushout (lbs.)	Torque-out (in. lbs.)	Tensile Strength (lbs.) (2) (3)	Test Bushing Hole Size For Pull Thru Tests (in.)
	256	75	.029" 304 Stainless Steel	89	4500	50	10	640	.104
440	13	.029" 304 Stainless Steel	89	4500	75	15	850	.112	
632	20	.029" 304 Stainless Steel	89	6000	75	20	1020	.138	

METRIC	Thread Code	Max. Nut Tightening Torque (N-m) (2) (3)	Test Sheet Thickness and Material (mm)	Sheet Hardness HRB	Installation (kN) (4)	Pushout (N)	Torque-out (N-m)	Tensile Strength (kN) (2) (3)	Test Bushing Hole Size For Pull Thru Tests (mm)
	M2.5	1.05	0.7 mm 304 Stainless Steel	89	20	200	1.35	3.05	3
M3	1.5	0.7 mm 304 Stainless Steel	89	20	300	1.85	3.63	3.5	
M3.5	2.1	0.7 mm 304 Stainless Steel	89	27	300	1.9	4.25	4	

### A4™/LA4™ NUTS

UNIFIED	Thread Code	Test Sheet Material		
		300 Series Stainless Steel		
		Installation (lbs.)	Retainer Pushout (lbs.)	Retainer Torque-out (in. lbs.)
440		9000	200	85
632		10000	200	85
832		12000	200	85
032		13000	250	125

METRIC	Thread Code	Test Sheet Material		
		300 Series Stainless Steel		
		Installation (kN)	Retainer Pushout (N)	Retainer Torque-out (N-m)
M3		40	890	9.6
M4		53	890	9.6
M5		57	1100	14.1

(1) Published installation forces are for general reference. Actual set-up and confirmation of complete installation should be made by observing proper seating of fastener as described in the installation steps. Other performance values reported are averages when all proper installation parameters and procedures are followed. Variations in mounting hole size, sheet material, and installation procedure may affect performance. Performance testing this product in your application is recommended. We will be happy to provide technical assistance and/or samples for this purpose.

(2) Head size is adequate to ensure failure in threaded area when tested with industry standard tensile bushing diameter.

(3) Tightening torque shown will induce preload of 70% of nut min axial strength with K or nut factor is equal to 0.20. In some applications tightening torque may need to be adjusted based on the actual K value. All tightening torques shown are based on 180 ksi/ Property Class 12.9 screws. For lower strength screws the tightening torque is proportionately less. For example, for 120 ksi screws, torque is 67% value shown. For 900 MPa screws (Property Class 9.8) torque value is 74% of value shown.

(4) Installation controlled by proper cavity depth in punch.



Get quote >>

Angic Global Solutions

1-888-872-0690 [www.AngicGlobal.com](http://www.AngicGlobal.com) 248

<https://www.AngicGlobal.com> Sales@AngicGlobal.com

# FASTENERS FOR USE IN STAINLESS STEEL SHEETS

## PERFORMANCE DATA

### F4™ NUTS

UNIFIED	Thread Code	Shank Code	Axial Tensile Strength (lbs.) (1)	Max. Screw Tightening Torque (2) (in. lbs.)	Test Sheet Material			
					300 Series Stainless Steel			
					Installation (lbs.)	Pushout (lbs.)		
256	1	2	130	1.50	7200	270		
440	1	2	165	2.50	7200	270		
632	1	2	190	3.50	7200	290		
832	1	2	230	5.25	9000	450		
032	1	2	280	7.50	9000	450		
0420	3	4	1035	36	14000	1000		

METRIC	Thread Code	Shank Code	Axial Tensile Strength (kN) (1)	Max. Screw Tightening Torque (2) (N-m)	Test Sheet Material			
					300 Series Stainless Steel			
					Installation (kN)	Pushout (N)		
M2	1	2	0.57	0.16	32	1200		
M2.5	1	2	0.68	0.23	32	1200		
M3	1	2	0.85	0.36	32	1200		
M4	1	2	1	0.58	40	2000		
M5	1	2	1.3	0.88	40	2000		
M6	3	4	4.5	3.7	65	4500		

### SO4™/BSO4™ STANDOFFS

UNIFIED	Thread Code	Max. Rec. Tightening Torque For Mating Screw (in. lbs.)	Test Sheet Material			
			.050" 300 Series Stainless Steel			
			Installation (lbs.)	Pushout (lbs.)	Torque-out (in. lbs.) (3)	Pull-thru (lbs.) (3)
440	4.75	5500	336	17	600	
6440	4.75	9500	647	30	680	
632	8.75	9500	647	30	680	
8632	8.75	10500	900	71	1392	
832	18	10500	900	71	1517	
032	32	10500	900	71	1368	

METRIC	Thread Code	Max. Rec. Tightening Torque For Mating Screw (N-m)	Test Sheet Material			
			1.3 mm 300 Series Stainless Steel			
			Installation (kN)	Pushout (N)	Torque-out (N-m) (3)	Pull-thru (N) (3)
M3	0.55	24.5	1493	2.36	2650	
3.5M3	0.55	42.3	2877	3.06	3025	
M3.5	0.91	42.3	2877	3.06	3025	
M4	2	46.7	4003	8.89	6458	
M5	3.6	46.7	4003	8.89	6226	

### TSO4™ STANDOFFS

Standoff "C" Dimension	Test Sheet Material					
	.025" / 0.64 mm 300 series stainless steel					
	Installation		Pushout		Torque-out (3)	
	(lbs.)	(kN)	(lbs.)	(N)	(in. lbs.)	(N-m)
.165" / 4.2 mm	5700	25.4	125	555	13	1.5
.212" / 5.39 mm	6800	30.3	160	710	22	2.5

### FH4™ STUDS

UNIFIED	Thread Code	Recommended Nut Tightening Torque (in. lbs.) (5)	Sheet Hardness HRB	Test Sheet Material			
				.060" Stainless Steel (4)			
				Installation (lbs.)	Pushout (lbs.)	Torque-out (in. lbs.)	Pull-thru (lbs.)
440	11	87	9000	450	16	800	
632	22	87	9500	540	27	1350	
832	35	86	11200	780	58	1800	
032	51	86	12000	800	95	2250	
0420	117	86	23000	1600	156	3900	

METRIC	Thread Code	Recommended Nut Tightening Torque (N-m) (5)	Sheet Hardness HRB	Test Sheet Material			
				1.5 mm Stainless Steel (4)			
				Installation (kN)	Pushout (N)	Torque-out (N-m)	Pull-thru (N)
M3	1.3	87	40	2220	1.8	3500	
M4	3.8	86	50	3210	6.5	8000	
M5	6	86	53	3560	10.7	10000	
M6	11	86	100	4200	15.9	14900	

- (1) Failure occurs in screw stripping using a 60 ksi screw and the shortest shank length fastener.
- (2) Torque values shown will produce a preload of 70% of axial tensile strength with nut factor "k" equal to .2. Threads may strip or head of the nut may bend and/or fail if screw is over-torqued beyond these values or if actual k value is less than .2.
- (3) Joint failure in torque-out and pull-thru will depend on the strength and type of screw being used. In some cases the failure will be in the screw and not in the self-clinching standoff. Please contact our Applications Engineering group with any questions.
- (4) Performance may be reduced for studs installed into thicker sheets.
- (5) Tightening torque shown is a theoretical value calculated to induce a load of 75% of minimum axial yield strength of the stud with an assumed K.

# FASTENERS FOR USE IN STAINLESS STEEL SHEETS

## PERFORMANCE DATA

### FHP™ STUDS

UNIFIED	Thread Code	Recommended Nut Tightening Torque (in. lbs.) <sup>(2)</sup>	Sheet Hardness HRB	Test Sheet Material			
				.060" Stainless Steel <sup>(1)</sup>			
				Installation (lbs.)	Pushout (lbs.)	Torque-out (in. lbs.)	Pull-thru (lbs.)
	440	8.1	86	9000	520	10.6	605
	632	16	86	9500	670	19.5	940
	832	28	86	11200	785	37.5	1415
	032	34	86	12000	800	59.5	1500

METRIC	Thread Code	Recommended Nut Tightening Torque (N-m) <sup>(2)</sup>	Sheet Hardness HRB	Test Sheet Material			
				1.5 mm (for M4&M5) 2 mm (for M3) Stainless Steel <sup>(1)</sup>			
				Installation (kN)	Pushout (N)	Torque-out (N-m)	Pull-thru (N)
	M3	1.3	86	40	2500	1.6	3500
	M4	2.9	86	50	3000	3.9	6000
	M5	4.4	86	53	3560	7.35	7320

### SGPC™ STUDS

UNIFIED	Thread Code	Max. Rec. Tightening Torque For Mating Nut (in. lbs.)	Sheet Hardness HRB	Test Sheet Material			
				Single sheet of .039" 300 Series Stainless Steel			
				Installation (lbs.)	Pushout (lbs.)	Torque-out (in. lbs.)	Pull-thru (lbs.)
	256	2.3	92	4000	425	5.2	415
	440	5	92	5000	450	8	512
	632	9	92	5500	460	15.8	811
	832	17	92	6500	480	29.3	1133
	032	27	92	7300	545	42.8	1273
	0420	58	92	10000	565	76.7	1721

METRIC	Thread Code	Max. Rec. Tightening Torque For Mating Nut (N-m)	Sheet Hardness HRB	Test Sheet Material			
				Single sheet of 1 mm 300 Series Stainless Steel			
				Installation (kN)	Pushout (N)	Torque-out (N-m)	Pull-thru (N)
	M2.5	0.41	92	20.1	2546	0.86	2561
	M3	0.74	92	21.8	2051	1.35	2851
	M4	1.7	92	28.5	2396	2.66	4000
	M5	3.5	92	35.6	3200	5.96	4284
	M6	5.9	92	42.3	3262	9.19	6311

### TP4™ PINS

UNIFIED	Pin Diameter Code	Test Sheet Material	
		300 Series Stainless Steel	
		Installation (lbs.)	Pushout (lbs.)
	125	8000	350
	187	12000	570
	250	14000	650

METRIC	Pin Diameter Code	Test Sheet Material	
		300 Series Stainless Steel	
		Installation (kN)	Pushout (N)
	3MM	35	1556
	4MM	45	2335
	5MM	54	2535
	6MM	60	2891

### PFC4™ CAPTIVE PANEL SCREWS

UNIFIED	Thread Code	Test Sheet Material	
		300 Series Stainless Steel	
		Installation (lbs.)	Retainer Pushout (lbs.)
	440	9100	350
	632	10300	400
	832	10800	450
	032	11800	550

METRIC	Thread Code	Test Sheet Material	
		300 Series Stainless Steel	
		Installation (kN)	Retainer Pushout (N)
	M3	40.5	1557
	M4	48	2002
	M5	52.5	2447

### SFP™ FASTENERS

Type and Size	Thickness Code	Test Sheet Material			
		Stainless Steel			
		Installation		Pushout of Panel 2 <sup>(3)</sup>	
		kN	lbs.	N	lbs.
SFP-3	1.0	13.5	3000	620	140
SFP-3	1.2	20	4500	830	186
SFP-3	1.6	22	5000	1500	340
SFP-5	1.0	18	4000	990	222
SFP-5	1.2	27	6000	1158	260
SFP-5	1.6	33	7500	3117	701

(1) Performance may be reduced for studs installed into thicker sheets.

(2) Tightening torque shown is a theoretical value calculated to induce a load of 75% of minimum axial yield strength of the stud with an assumed K.

(3) In most applications, pullout strength of the SpotFast® fastener in Panel 1 exceeds pushout strength of Panel 2.



Get quote »

Angic Global Solutions

1-888-872-0690 [t.com](http://www.AngicGlobal.com) 250

<https://www.AngicGlobal.com> Sales@AngicGlobal.com

# FASTENERS FOR USE IN STAINLESS STEEL SHEETS

## OTHER FASTENERS FOR CONSIDERATION TO USE IN STAINLESS STEEL SHEETS

### PF11MW™ CAPTIVE PANEL SCREWS



Floating captive panel screw with unique flare-mount feature allows fastener to "float" in mounting hole and compensate for mating thread alignment. (See PEM® [Bulletin PF](#))

### PF11MF™ CAPTIVE PANEL SCREWS



Flare-mounted captive panel screw that installs into any panel material and is flush on back side of panel. (See PEM® [Bulletin PF](#))

### MPP™ PINS



Self-clinching microPEM® pins that can be installed into stainless steel sheets as thin as .02"/0.5mm. (See PEM® [Bulletin MPF](#))

### MSO4™ STANDOFFS



Self-clinching microPEM® standoffs that can be installed into stainless steel sheets as thin as .016"/0.4mm. (See PEM® [Bulletin MPF](#))

### T4™ TACKPIN® FASTENERS



microPEM® TackPin® fasteners enable sheet-to-sheet attachment in stainless steel sheets in applications where disassembly is not required. (See PEM® [Bulletin MPF](#))

### WN/WNS WELD NUTS



Designed to overcome many problems such as burn-outs, complicated electrodes and pilots, indexing and re-tapping to remove weld spatter. (See PEM® [Bulletin WN](#))

### ATLAS® BLIND THREADED INSERTS



Attach to panels of any hardness and provide strong and reusable permanent threads in sheet materials where only one side is accessible. (See [ATLAS® Catalog](#))



Fastener drawings and models are available at [www.pemnet.com](http://www.pemnet.com)

## INSTALLATION INTO STAINLESS STEEL SHEETS DOS AND DON'TS

### "Dos"

- DO** select the proper fastener material to meet corrosion requirements.
- DO** make certain that panel material is in the annealed condition.
- DO** make certain that hole punch is kept sharp to minimize work hardening around hole.
- DO** provide mounting hole of specified size for each fastener.
- DO** maintain the hole punch diameter to no greater than +.001"/.025 mm over the minimum recommended mounting hole.
- DO** make certain that fastener is properly positioned within hole before applying installation force.
- DO** make certain that fastener is not installed adjacent to bends or other highly cold-worked areas.
- DO** apply squeezing force between parallel surfaces.
- DO** utilize recommended installation tooling when installing fasteners.
- DO** install fastener in punched side of hole.
- DO** apply sufficient force to totally embed clinching ring (where applicable) around entire circumference and to bring shoulder squarely in contact with sheet. For all other fasteners, installation will be complete when the head is flush with the panel surface.

### "Don'ts"

- DON'T** attempt to install any self-clinching fastener other than types SP, SMPP, A4, LA4, F4, S04, BS04, TS04, FH4, FHP, SGPC, TP4, PFC4, and SFP into a stainless steel sheet.
- DON'T** deburr mounting holes on either side of sheet before installing fasteners - deburring will remove metal required for clinching fastener into sheet.
- DON'T** install fastener closer to edge of sheet than minimum edge distance - unless a special fixture is used to restrict bulging of sheet edge.
- DON'T** install fastener near bends or other highly cold worked areas where sheet hardness may be greater than the limit for the fastener.
- DON'T** over-squeeze. It will crush the head, distort threads, and buckle the sheet. Be certain to determine optimum installation force by test prior to production runs.
- DON'T** attempt to insert fastener with a hammer blow - under any circumstances. A hammer blow won't permit the sheet metal to flow and develop an interlock with the fastener's contour.
- DON'T** install screw in the head side of fastener. Install from opposite side so that the fastener load is toward sheet. The clinching force is designed only to hold the fastener during handling and to resist torque during assembly.



PEM® brand SNAP-TOP® standoffs are designed for permanent installation into metal panels or PC Boards



# SSA™

## SNAP-TOP® STANDOFFS

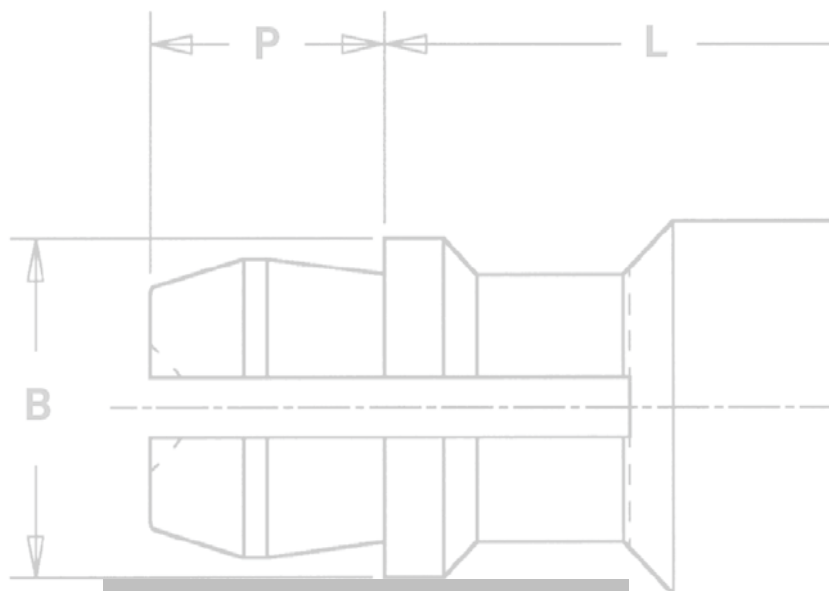

Get quote >>

Angic Global Solutions

1-888-872-0690

<https://www.AngicGlobal.com> [Sales@AngicGlobal.com](mailto:Sales@AngicGlobal.com)

# SNAP-TOP® STANDOFFS

**PEM® SNAP-TOP® Standoffs are designed for permanent installation into metal panels or PC boards.**

- Spring action to hold PC Boards and subassemblies securely.
- Allows for quick removal.
- Eliminates screws and other threaded hardware.
  - Less parts to handle during assembly.
  - Less risk of damaging delicate circuitry because of loose parts falling into your equipment.
- Available in three different mounting styles:
  - Self-clinching for installation into ductile materials
  - Broaching for installation into PC Board and brittle material.
  - Surface mount for installation to PC Board
- Permanently installed in the panel.

Installation forces, pushout and snap forces are listed on page 256.

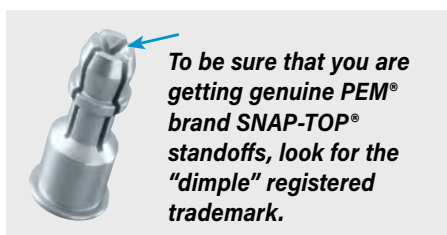
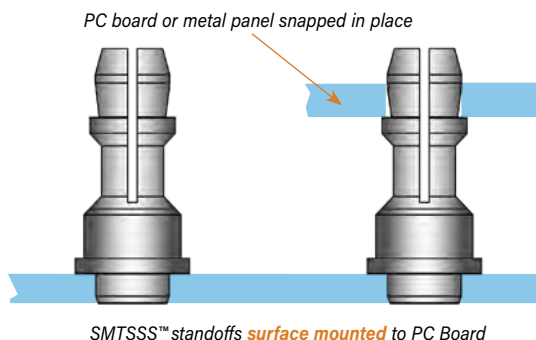
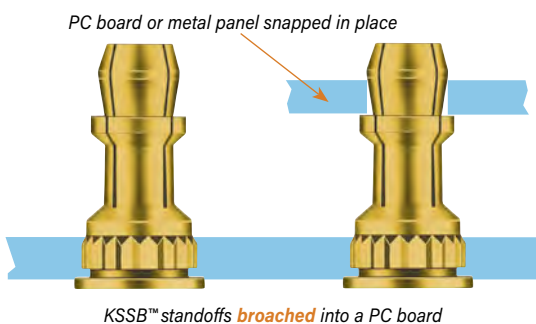
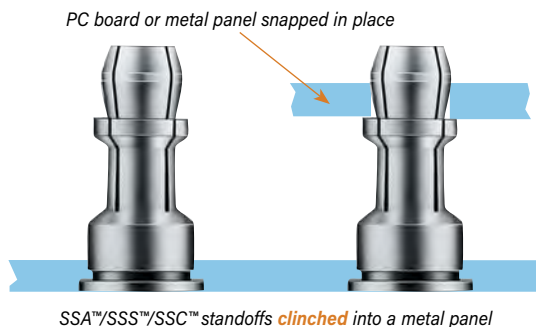

# SNAP-TOP® STANDOFFS

## SSA™/SSS™/SSC™ STANDOFFS FOR CLINCHING INTO METAL SHEETS

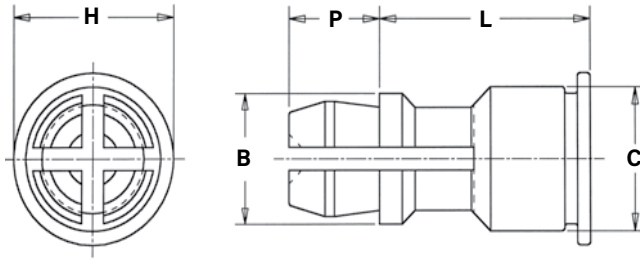

### PART NUMBER DESIGNATION

<b>SS</b>	<b>A</b>	-	<b>156</b>	-	<b>10</b>	
<b>SS</b>	<b>S</b>	-	<b>156</b>	-	<b>10</b>	<b>ZI</b>
<b>SS</b>	<b>C</b>	-	<b>156</b>	-	<b>10</b>	
Type	Material		Mounting Hole A Diameter Code		Length Code	Finish Code

### FASTENER MATERIAL:

SSA: Aluminum  
 SSS: Carbon Steel  
 SSC: 400 Series Stainless Steel

### FINISH:

SSA: Natural  
 SSS: ZI - Zinc plated per ASTM B633, SC1 (5µm), Type III, colorless, plus clear chromate <sup>(1)</sup>  
 SSC: Passivated and/or tested per ASTM A380

All dimensions are in inches.

UNIFIED	Type			Panel 2 (Top) Mounting Hole Diameter Code	Length Code "L" ±.005 (Length Code in 32nds of an inch)										B ±.005	C Max.	H ±.005	P ±.005
	Fastener Material																	
	Aluminum	Carbon Steel	Stainless Steel															
	SSA	SSS	SSC	156	.250	.312	.375	.437	.500	.562	.625	.750	.875	1.00				
					8	10	12	14	16	18	20	24	28	32 <sup>(2)</sup>				

All dimensions are in millimeters.

METRIC	Type			Panel 2 (Top) Mounting Hole Diameter Code	Length Code "L" ±0.13 (Length Code in millimeters)								B ±0.13	C Max.	H ±0.13	P ±0.13	
	Fastener Material																
	Aluminum	Carbon Steel	Stainless Steel														
	SSA	SSS	SSC	4MM	8	10	12	14	16	18	20	22	25 <sup>(2)</sup>				

(1) See PEM Technical Support section of our web site for related plating standards and specifications.

(2) This length not available for Type SSA aluminum fasteners.

### APPLICATION DATA

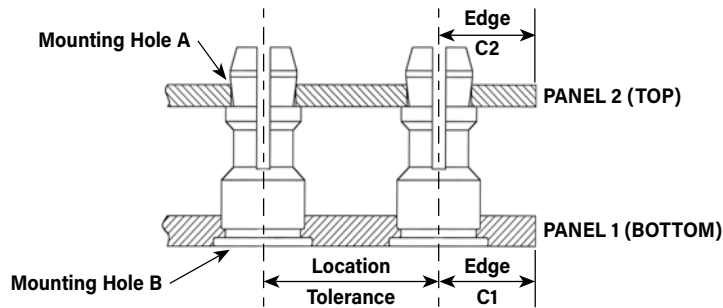

All dimensions are in inches.

UNIFIED	Panel 1							Panel 2				
	Type	Hardness Max. (2)	Bottom Mounting Hole B +.003 -.000	Panel Material	Thickness Min.	Edge Distance C, Min.	Location Tolerance	Hardness Max.	Top Mounting Hole A +.003 -.000	Panel Material	Thickness Range (3)	Edge Distance C, Min.
		SSA	HRB 50 / HB 82	.213	Metal	.040	.260	±.005	No Limit	.156	PC Board or Metal	.040 - .070
	SSS	HRB 60 / HB 107										
	SSC	HRB 70 / HB 125										

All dimensions are in millimeters.

METRIC	Panel 1							Panel 2				
	Type	Hardness Max. (2)	Bottom Mounting Hole B +0.08	Panel Material	Thickness Min.	Edge Distance C, Min.	Location Tolerance	Hardness Max.	Top Mounting Hole A +0.08	Panel Material	Thickness Range (3)	Edge Distance C, Min.
		SSA	HRB 50 / HB 82	5.41	Metal	1	6.6	±0.13	No Limit	4	PC Board or Metal	1 - 1.8
	SSS	HRB 60 / HB 107										
	SSC	HRB 70 / HB 125										

(2) HRB - Hardness Rockwell "B" Scale. HB - Hardness Brinell.

(3) Available for thicker boards on special order.



Get quote >>

Angic Global Solutions

1-888-872-0690 [www.angic.com](http://www.angic.com) 254

<https://www.AngicGlobal.com> Sales@AngicGlobal.com

# SNAP-TOP® STANDOFFS

## KSSB™ STANDOFFS FOR BROACHING INTO PC BOARDS

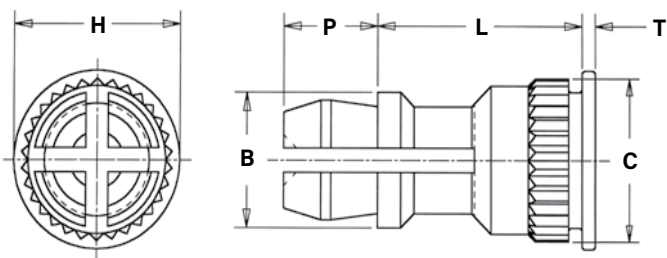

### PART NUMBER DESIGNATION

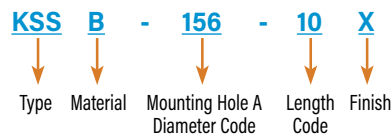

### FASTENER MATERIAL:

Brass

### FINISH:

Standard: X - Plain

Optional: ET - Electro-plated Tin, ASTM B545 Class B (5µm) with preservative coating, annealed <sup>(1)</sup>

(Optional ET finish is available on special order with additional charge.)

All dimensions are in inches.

UNIFIED	Type	Panel 2 (Top) Mounting Hole Diameter Code	Length Code "L" ±.005 (Length Code in 32nds of an inch)										B ±.005	C ±.003	H ±.005	P ±.005	T ±.005
			.250	.312	.375	.437	.500	.562	.625	.750	.875	1.00					
KSSB	156	8	10	12	14	16	18	20	24	28	32	.188	.226	.250	.141	.020	

All dimensions are in millimeters.

METRIC	Type	Panel 2 (Top) Mounting Hole Diameter Code	Length Code "L" ±0.13 (Length Code in millimeters)									B ±0.13	C ±0.08	H ±0.13	P ±0.13	T ±0.13
			8	10	12	14	16	18	20	22	25					
KSSB	4MM	8	10	12	14	16	18	20	22	25	4.78	5.74	6.35	3.58	0.51	

(1) See PEM Technical Support section of our web site for related plating standards and specifications.

### APPLICATION DATA

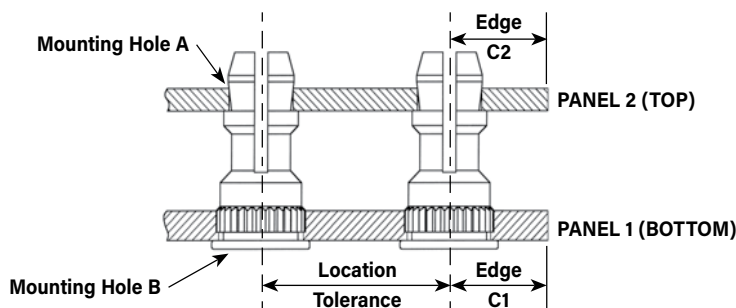

All dimensions are in inches.

UNIFIED	Type	Panel 1					Panel 2					
		Hardness Max. (2)	Bottom Mounting Hole B +.003 -.000	Panel Material	Thickness Min.	Edge Distance C, Min.	Location Tolerance	Hardness Max.	Top Mounting Hole A +.003 -.000	Panel Material	Thickness Range (3)	Edge Distance C, Min.
		KSSB	HRB 65 / HB 116	.213	PC Board	.050	.220	±.005	No Limit	.156	PC Board or Metal	.040 - .070

All dimensions are in millimeters.

METRIC	Type	Panel 1					Panel 2					
		Hardness Max. (2)	Bottom Mounting Hole B +0.08	Panel Material	Thickness Min.	Edge Distance C, Min.	Location Tolerance	Hardness Max.	Top Mounting Hole A +0.08	Panel Material	Thickness Range (3)	Edge Distance C, Min.
		KSSB	HRB 65 / HB 116	5.41	PC Board	1.27	5.59	±0.13	No Limit	4	PC Board or Metal	1 - 1.8

(2) HRB - Hardness Rockwell "B" Scale. HB - Hardness Brinell.

(3) Available for thicker boards on special order.

# SNAP-TOP® STANDOFFS

## SMTSSS™ REELFAST® SNAP-TOP® STANDOFFS



**NOTE: REELFAST® SNAP-TOP® SMTSSS™ standoffs are for on-only applications. For removal applications, mounting hole A can be increased to reduce removal force.**

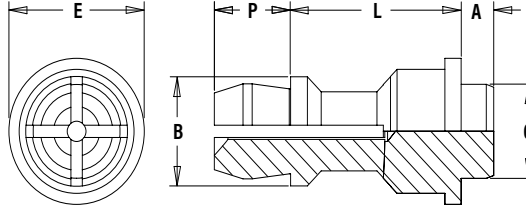

**NEW!**

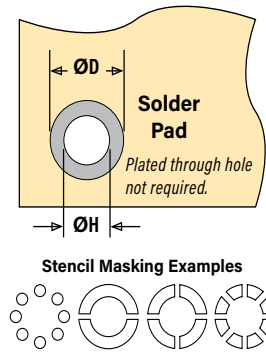

**FASTENER MATERIAL:** Carbon Steel **FINISH:** ET - Electro-plated Tin, ASTM B545 Class A with clear preservative coating, annealed <sup>(1)(2)</sup>

(1) See [PEM Technical Support](#) section of our web site for related plating standards and specifications.  
 (2) Optimal solderability life noted on packaging.

All dimensions are in inches.

UNIFIED	Top Board Mounting Hole A Diameter Code	Type and Material	Length Code "L" ±.005 (Length Code in 32nds of an inch)		Min. Sheet Thickness	A Max.	C Max.	E ±.005	B ±.005	P ±.005	ØH Hole Size in Sheet +.003 -.000	ØD Min. Solder Pad
			.250	.375								
	156	SMTSSS	8	12	.060	.060	.161	.250	.188	.141	.166	.276

All dimensions are in millimeters.

METRIC	Top Board Mounting Hole A Diameter Code	Type and Material	Length Code "L" ±0.13 (Length Code in millimeters)			Min. Sheet Thickness	A Max.	C Max.	E ±0.13	B ±0.13	P ±0.13	ØH Hole Size in Sheet +0.08	ØD Min. Solder Pad
			6	8	10								
	4MM	SMTSSS	6	8	10	1.53	1.53	4.09	6.35	4.8	3.58	4.22	7

### NUMBER OF PARTS PER REEL

Type, Material and Size	Length Code / Number of Parts per Reel		
SMTSSS-156	-8 / 280	-12 / 220	
SMTSSS-4MM	-6 / 300	-8 / 250	-10 / 200



### PART NUMBER DESIGNATION

**SMTSS S - 156 - 12 ET**  
 ↓ ↓ ↓ ↓ ↓  
 Type Material Mounting Hole A Length Finish  
 Diameter Code Code

Packaged on 330 mm recyclable reels. Tape width is 24 mm.  
 Supplied with polyimide patch for vacuum pick up.  
 Reels conform to EIA-481.

### APPLICATION DATA

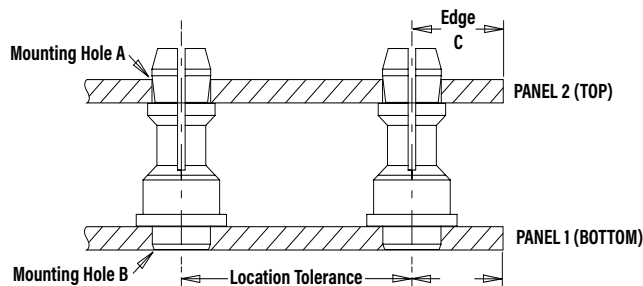

All dimensions are in inches.

UNIFIED	Type and Material	Panel 1				Panel 2					
		Hardness Max.	Bottom Mounting Hole B +.003 -.000	Panel Material	Thickness Min.	Location Tolerance	Hardness Max.	Top Mounting Hole A +.003 -.000	Panel Material	Thickness Range	Edge Distance C Min.
	SMTSSS	No Limit	.166	P.C. Board	.060	±.005	No Limit	.156	P.C. Board or Metal	.040 - .070	.100

All dimensions are in millimeters.

METRIC	Type and Material	Panel 1				Panel 2					
		Hardness Max.	Bottom Mounting Hole B +0.08	Panel Material	Thickness Min.	Location Tolerance	Hardness Max.	Top Mounting Hole A +0.08	Panel Material	Thickness Range	Edge Distance C Min.
	SMTSSS	No Limit	4.22	P.C. Board	1.53	±0.13	No Limit	4	P.C. Board or Metal	1 - 1.8	2.54



Get quote >>

Angic Global Solutions

1-888-872-0690 [t.com 256](#)

<https://www.AngicGlobal.com> Sales@AngicGlobal.com

## INSTALLATION

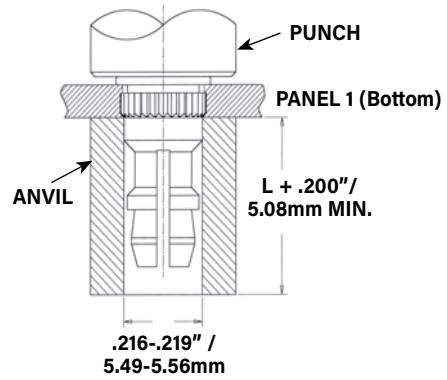
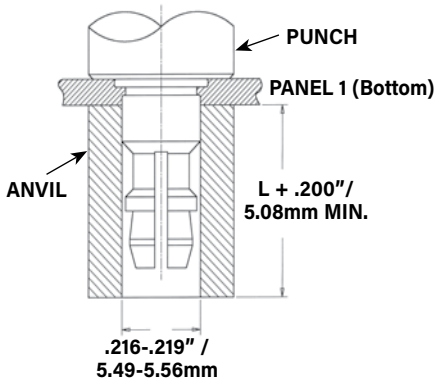

### SSA™/SSS™/SSC™ Standoffs

1. Prepare properly sized mounting hole in Panel 1 (Bottom).
2. Place the fastener through the mounting hole (preferably the punch side) of the panel and into the anvil as shown in the drawing.
3. With punch and anvil surfaces parallel, apply only enough squeezing force to embed the head flush with the panel.

### KSSB™ Standoffs

1. Prepare properly sized mounting hole in Panel 1 (Bottom).
2. Place the fastener through the mounting hole of the board and into the anvil as shown in the drawing.
3. With punch and anvil surfaces parallel, apply only enough squeezing force to bring the head into contact with the board.

### PEMSERTER® Installation Tooling

Type	Anvil Part Number	Punch Part Number
SSA, SSS, SSC, KSSB	970200015300	975200048

### SMTSSS™ Standoffs

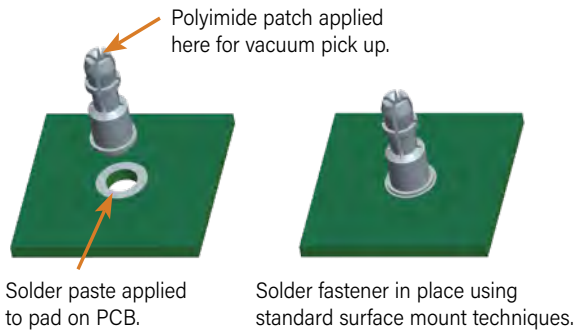

### INSTALLATION NOTES

- For best results we recommend using a HAEGER® or PEMSERTER® machine for installation of PEM® self-clinching fasteners. Please check our website for more information.
- Visit the Animation Library on our website to view the installation process [for select products](#).

# SNAP-TOP® STANDOFFS

## PERFORMANCE DATA<sup>(1)</sup>

### SSA™/SSS™/SSC™ Standoffs - Self-clinching

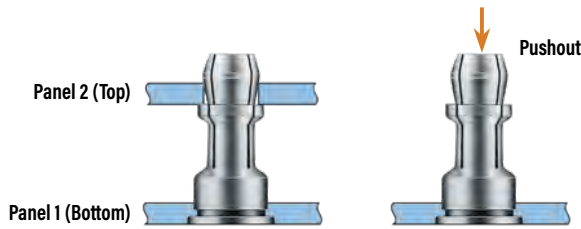

### KSSB™ Standoffs - Broaching

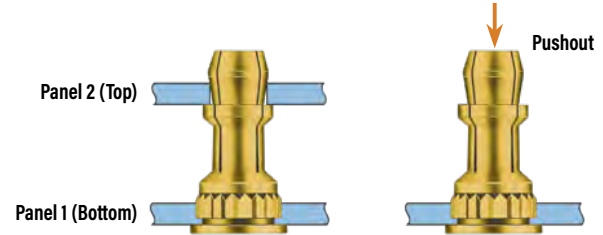

UNIFIED	Panel 1 (Bottom)				Panel 2 (Top) (Removable)		
	Type	Test Sheet Material	Installation (lbs.)	Pushout (lbs.)	Max. First on Snap Force (lbs.)	Min. First off Snap Force (lbs.)	Min. 15th off Snap Force (lbs.)
	SSA	Aluminum	1500	200	13	3	1
	SSS	Aluminum	1500	200	20	6	2
	SSC	Aluminum	1500	200	20	6	2
	SSS	Cold-rolled Steel	3600	400	20	6	2
	SSC	Cold-rolled Steel	3600	400	20	6	2
	KSSB	FR-4 Fiberglass	500	110	13	3	1

METRIC	Panel 1 (Bottom)				Panel 2 (Top) (Removable)		
	Type	Test Sheet Material	Installation (kN)	Pushout (N)	Max. First on Snap Force (N)	Min. First off Snap Force (N)	Min. 15th off Snap Force (N)
	SSA	Aluminum	6.7	890	58	13	4
	SSS	Aluminum	6.7	890	89	27	9
	SSC	Aluminum	6.7	890	89	27	9
	SSS	Cold-rolled Steel	16	1780	89	27	9
	SSC	Cold-rolled Steel	16	1780	89	27	9
	KSSB	FR-4 Fiberglass	2.2	484	58	13	4

### SMTSSS™ Standoffs - Surface Mount

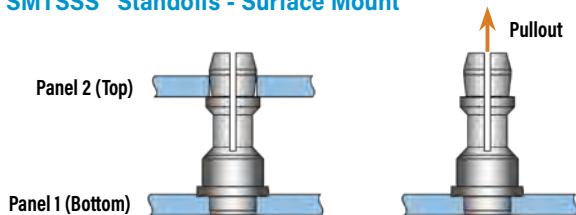

Type, Material and Size	Panel 1 (Bottom)		Panel 2 (Top)	
	Test Sheet Material	Pullout <sup>(2)</sup>	Max. Snap-on Force	Min. Snap Retention Force
SMTSSS-156	.062" Single Layer FR-4	113 lbs.	20 lbs.	6 lbs.
SMTSSS-4MM	1.58 mm Single Layer FR-4	500 N	89 N	27 N

#### TESTING CONDITIONS

Oven	Quad ZCR convection oven with 4 zones
High Temp	473 °F / 245 °C
Board Finish	62% Sn, 38% Pb
Board	.062" / 1.58 mm thick, Single Layer FR-4
Screen Printer	Ragin Manual Printer
Vias	None
Spokes	2 Spoke Pattern
Paste	Alpha CVP-390 Sn96.5/3.0Ag/0.5Cu (SAC305)
Stencil	.0067" / 0.17 mm thick

(1) Published installation forces are for general reference. Actual set-up and confirmation of complete installation should be made by observing proper seating of fastener as described in the installation steps. Other performance values reported are averages when all proper installation parameters and procedures are followed. Variations in mounting hole size, sheet material, and installation procedure may affect performance. Performance testing this product in your application is recommended. We will be happy to provide technical assistance and/or samples for this purpose.

(2) With lead-free paste. Average values of 30 test points. The data presented here is for general comparison purposes only. Actual performance is dependent upon application variables. We will be happy to provide samples for you to install. If required, we can also test your installed hardware and provide you with the performance data specific to your application.



Get quote >>

Angic Global Solutions

1-888-872-0690 [www.AngicGlobal.com](http://www.AngicGlobal.com) 258

[www.AngicGlobal.com](http://www.AngicGlobal.com) Sales@AngicGlobal.com



PEM® TY-D® hardware provides secure metal attachment points for mounting wires to electronic chassis.



**TD™**

**SELF-CLINCHING TY-D®  
CABLE TIE-MOUNTS**

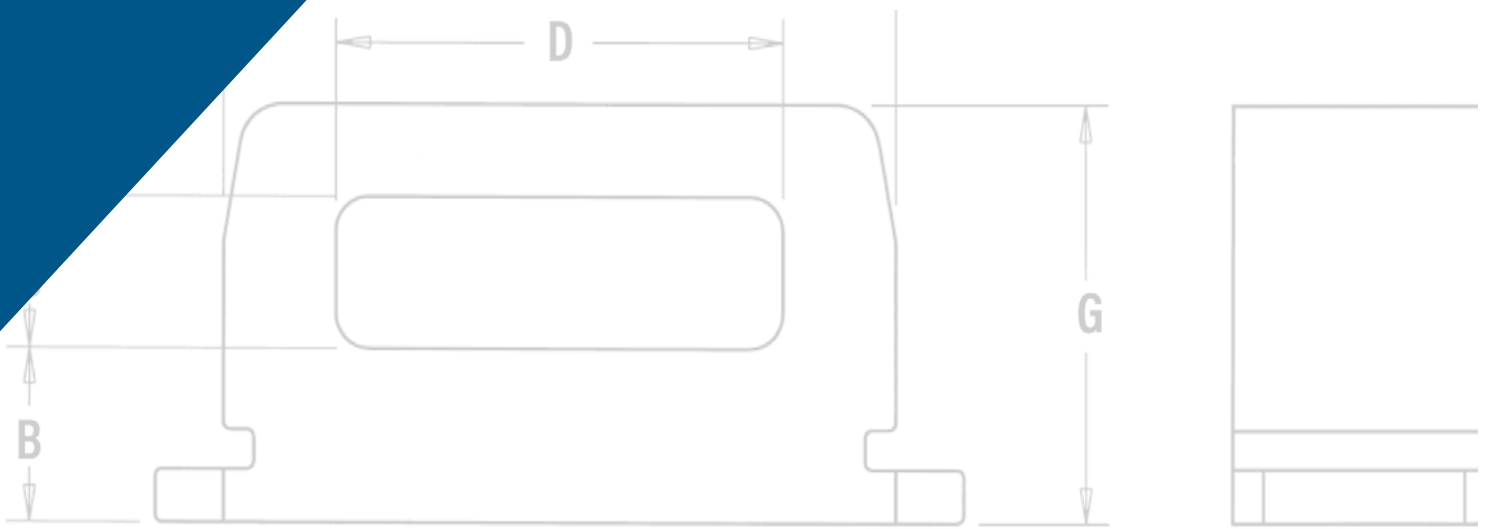

Get quote »

Angic Global Solutions

1-888-872-0690

<https://www.AngicGlobal.com> [Sales@AngicGlobal.com](mailto:Sales@AngicGlobal.com)



## SELF-CLINCHING TY-D® CABLE TIE-MOUNTS

PEM® TY-D® self-clinching tie-mounts provide secure metal attachment points for mounting wires to electronic chassis or enclosures. TY-D® hardware can be a great improvement over traditional mounting methods. They can be placed with assurance at designed locations and angles to remain secure for the life of the assembly.

- Installs quickly and permanently without screws
- Eliminates the use of adhesives that typically fail over time and temperature cycling
- Will not protrude on the reverse side, panel remains flush
- Fasteners ensure wire placement in desired location



**TDS™ cable tie-mounts** allow users to easily slide ties through the hardware's "eye" for fast cable mounting.

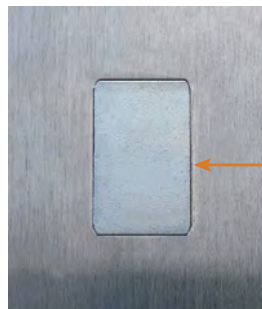
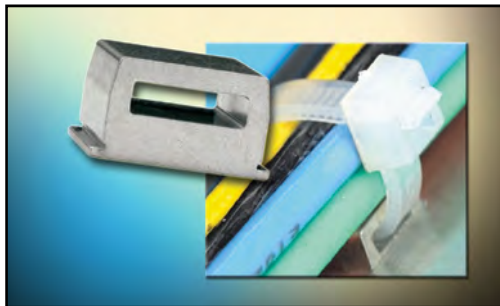

Depending on placement of the fastener within the mounting hole, on the reverse side of the sheet, a slight gap may be noticeable along the non-clinching edges of the fastener after installation. If gap is not acceptable in your application, check with [techsupport](#) for a solution.

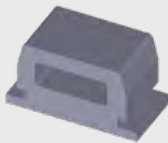

Fastener drawings and models are available at [www.pemnet.com](http://www.pemnet.com)

# SELF-CLINCHING TY-D® CABLE TIE-MOUNTS

## TDS™ CABLE TIE-MOUNTS

### PART NUMBER DESIGNATION

**TD** **S** - **60** - **6**  
**TD** **S** - **60** - **6** **ZI**

↓      ↓      ↓      ↓      ↓  
 Type   Material   Profile   Length   Finish  
       Code                    Code        Code        Code

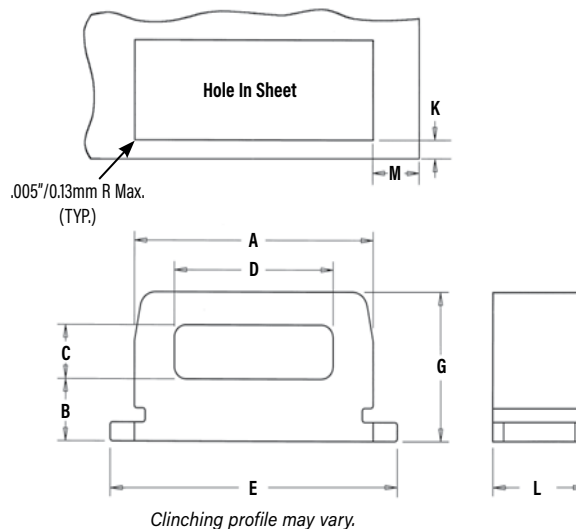
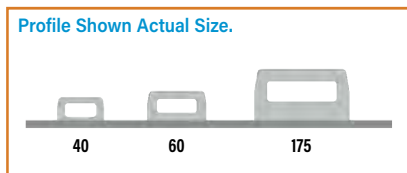

All dimensions are in inches.

UNIFIED	Type	Profile <sup>(1)</sup>	Length Code	Length L ±.003	Sheet Thickness	Hole Size In Sheet +.002 -.001	A ±.003	B ±.006	C ±.006	D ±.006	E ±.006	Height G ±.006	Min. Hole Edge To Sheet Edge K	Min. Hole Edge To Sheet Edge M
	Stainless Steel													
TDS	40	4	.121	.040 - .050	.250 x .125	.246	.055	.065	.160	.308	.150	.040	.147	
TDS	60	6	.184	.040 - .070	.312 x .187	.308	.075	.065	.205	.370	.180	.040	.196	
TDS	175	12	.371	.040 - .125	.500 x .375	.496	.130	.095	.360	.562	.285	.040	.262	

All dimensions are in millimeters.

METRIC	Type	Profile <sup>(1)</sup>	Length Code	Length L ±0.08	Sheet Thickness	Hole Size In Sheet +0.05 -0.03	A ±0.08	B ±0.15	C ±0.15	D ±0.15	E ±0.15	Height G ±0.15	Min. Hole Edge To Sheet Edge K	Min. Hole Edge To Sheet Edge M
	Stainless Steel													
TDS	40	4	3.07	1.02 - 1.27	6.35 x 3.18	6.25	1.4	1.65	4.06	7.82	3.81	1.02	3.73	
TDS	60	6	4.67	1.02 - 1.78	7.93 x 4.75	7.82	1.91	1.65	5.21	9.4	4.57	1.02	4.98	
TDS	175	12	9.42	1.02 - 3.18	12.7 x 9.53	12.6	3.3	2.4	9.14	14.28	7.24	1.02	6.65	

(1) Reference to typical load rating (in pounds) for appropriate size nylon cable tie.

## MATERIAL AND FINISH SPECIFICATIONS

**Material:** 17-4 Stainless Steel

**Standard Finish:** Passivated and/or tested per ASTM A380

**Optional Finish:** ZI - Zinc plated 8µm, Colorless, over Nickel Strike <sup>(2)</sup> <sup>(3)</sup>

**For use in Sheet Hardness:** HRB 70 / HB 125 or Less <sup>(4)</sup>

(2) See PEM [Technical Support](#) section of our web site for related plating standards and specifications.

(3) When applied to stainless steel base metal a nickel strike is used under the zinc for improved adhesion

(4) HRB - Hardness Rockwell "B" Scale. HB - Hardness Brinell.



Get quote >>

Angic Global Solutions

1-888-872-0690

[et.com](#) 261

<https://www.AngicGlobal.com> Sales@AngicGlobal.com

# SELF-CLINCHING TY-D® CABLE TIE-MOUNTS

## INSTALLATION

1. Punch a properly sized rectangular mounting hole in the sheet. Do not perform any secondary operations such as deburring.
2. Place the fastener through the mounting hole (preferably the punch side) and into the anvil.
3. With the installation punch and anvil surfaces parallel, apply a squeezing force until the bottom of the fastener becomes flush with the sheet.

## PEMSERTER® Installation Tooling

All dimensions are in inches.

UNIFIED	Part Number	W ±.001	Anvil Part Number	Punch Part Number
	TDS-40-4	.251	8006136	8003076
	TDS-60-6	.313	8006137	
	TDS-175-12	.501	8006138	

All dimensions are in millimeters.

METRIC	Part Number	W ±0.03	Anvil Part Number	Punch Part Number
	TDS-40-4	6.36	8006136	8003076
	TDS-60-6	7.95	8006137	
	TDS-175-12	12.73	8006138	

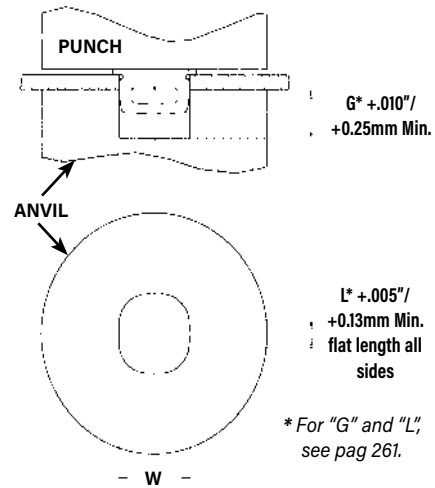

**NOTE:** The punch must be large enough to cover the entire base of the fastener to ensure proper installation.

### INSTALLATION NOTES

- For best results we recommend using a HAEGER® or PEMSERTER® machine for installation of PEM® self-clinching fasteners. Please e-mail [installationmachineinfo@pemnet.com](mailto:installationmachineinfo@pemnet.com) for more information.
- Visit the Animation Library on our website to view the installation process [for this product](#).

# SELF-CLINCHING TY-D® CABLE TIE-MOUNTS

## PERFORMANCE DATA<sup>(1)</sup>

UNIFIED	Part Number	Test Sheet Material							
		Cold-rolled Steel				5052-H34 Aluminum			
		Installation (lbs.)	Pushout (lbs.)	Pull Thru (lbs.)	Side Load (lbs.)	Installation (lbs.)	Pushout (lbs.)	Pull Thru (lbs.)	Side Load (lbs.)
TDS-40-4	1800	175	100	90	1000	90	100	90	
TDS-60-6	2500	260	160	100	1500	140	160	100	
TDS-175-12	4000	350	175	140	3000	235	175	140	

METRIC	Part Number	Test Sheet Material							
		Cold-rolled Steel				5052-H34 Aluminum			
		Installation (kN)	Pushout (N)	Pull Thru (N)	Side Load (N)	Installation (kN)	Pushout (N)	Pull Thru (N)	Side Load (N)
TDS-40-4	8	780	445	400	4.5	400	445	400	
TDS-60-6	11	1160	712	445	6.7	620	712	445	
TDS-175-12	17.7	1560	780	620	13.3	1040	780	620	

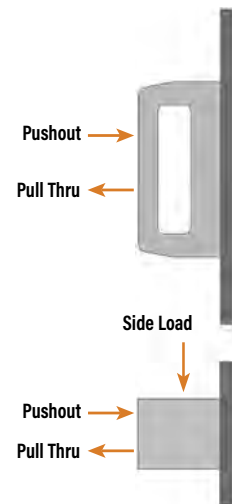

(1) Published installation forces are for general reference. Actual set-up and confirmation of complete installation should be made by observing proper seating of fastener as described in the installation steps. Other performance values reported are averages when all proper installation parameters and procedures are followed. Variations in mounting hole size, sheet material, and installation procedure may affect performance. Performance testing this product in your application is recommended. We will be happy to provide technical assistance and/or samples for this purpose.

## MOUNTING HOLE EXAMPLES

The mounting hole is defined by two dimensions. The two thick lines shown must be straight for the entire length defined by "Side 2" and must be separated by the distance shown as "Side 1" (Side 1 and Side 2 are the two dimensions given for the mounting hole on pages 3 and 4). The illustration shows three examples (#1, #2, and #3) of how it can be achieved. Example #4 in the lower right side will not work.

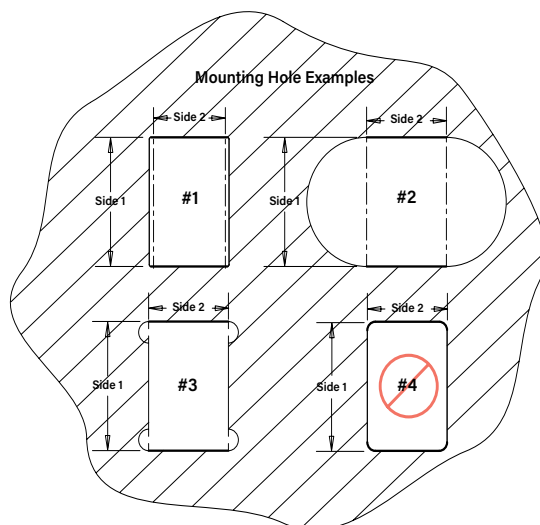



Get quote 



PEM® VariMount® bonding fasteners are assemblies comprised of standard PEM® fasteners mounted permanently into base plates.



VM™

PEM® VARIMOUNT®  
BONDING FASTENERS

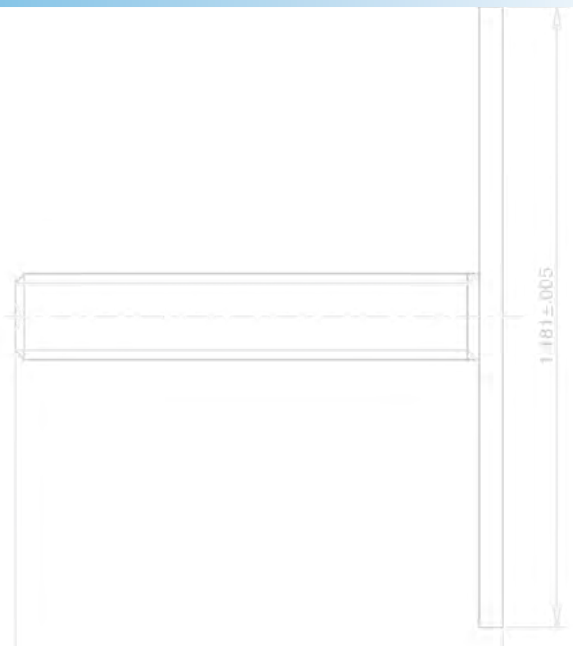
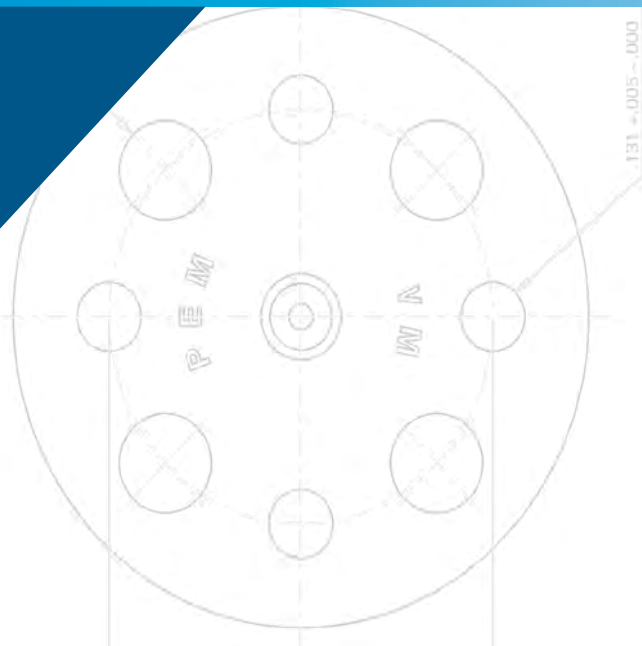

Get quote »

Angic Global Solutions

1-888-872-0690

<https://www.AngicGlobal.com> [Sales@AngicGlobal.com](mailto:Sales@AngicGlobal.com)

# PEM® VARIMOUNT® BONDING FASTENERS

The PEM® VariMount® fastening system eliminates issues associated with welding. The assembly is comprised of a standard PEM® nut, stud or standoff mounted permanently into a base plate. The assembly can then be fastened or bonded to assorted panel types in a variety of ways:

### Mounting Methods:

- Mold-in
- Laminate within composite layers
- Surface bonding
- Rivets
- Loose hardware (nuts, bolts, screws)
- Self-clinching fasteners
- Blind threaded rivets
- Adhesives or adhesive tape
- Hollow wall anchors
- Spot welding

### Mounts on or in:

- Composites (Carbon fiber, fiberglass)
- Plastics
- Metal
- Wall board
- Any rigid material or panel

VariMount® assemblies are available with either steel or stainless steel base plates depending on the fastener that is selected. The VariMount® base plate's radial holes provide various mounting options.

Base plates can also be purchased separately. See page 267 for dimensional data and part numbers.

## VARIMOUNT® ASSEMBLY USING SELF-CLINCHING TECHNOLOGY

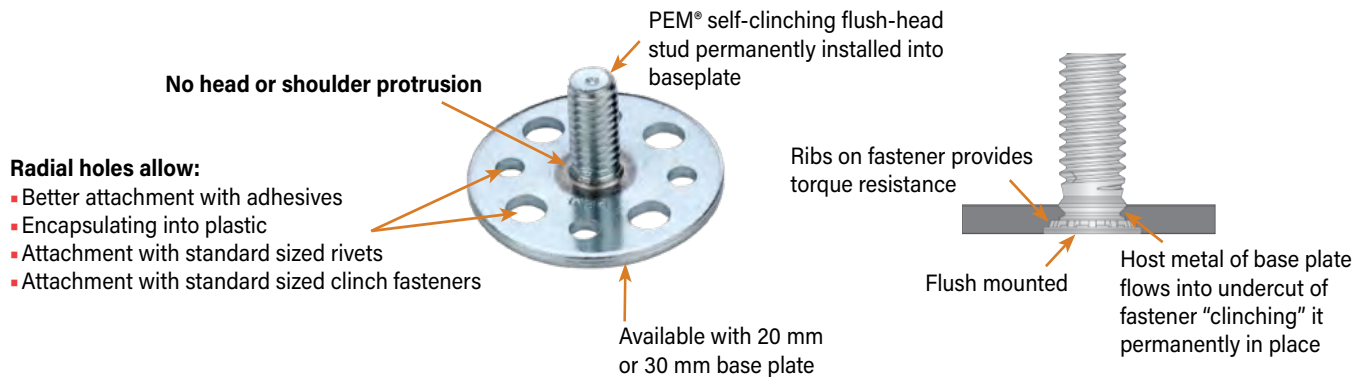

## TYPICAL MOUNTING METHODS

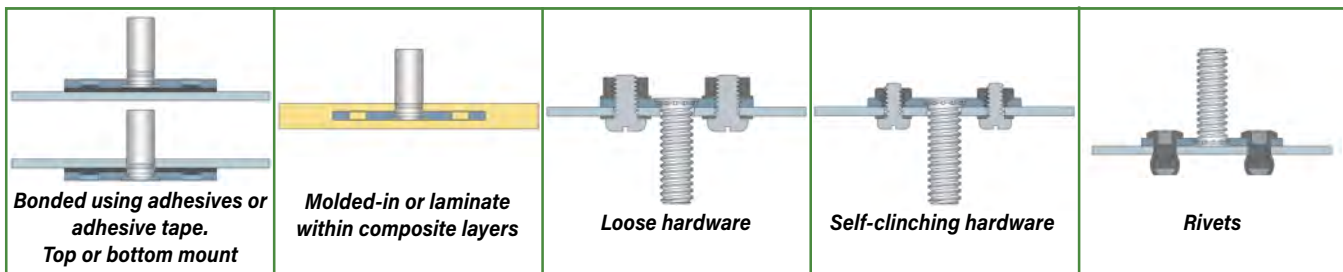

## ASSEMBLY PART NUMBER DESIGNATION

<b>VM</b>		<b>30</b>	<b>FH</b>	<b>- 0420</b>	<b>- 16</b>	<b>ZI</b>
<b>VM</b>	<b>C</b>	<b>30</b>	<b>FHP</b>	<b>- 032</b>	<b>- 16</b>	
VariMount Fastener Style	Base Plate Material Code (1)	Base Plate Diameter (2)	Fastener Type	Fastener Thread Code	Fastener Length Code	Fastener Finish Code (3) (if applicable)
Base plate prefix			PEM® fastener part number			

A VariMount® assembly part number includes a base plate prefix paired with a standard PEM® fastener part number.

- (1) "Blank" equals steel base plate and "C" equals stainless steel base plate.
- (2) See page 5 for complete dimensional information.
- (3) Required on steel assemblies.

# PEM® VARIMOUNT® BONDING FASTENERS

The charts below show PEM® fastener types/sizes that are offered as standard VariMount® assemblies.

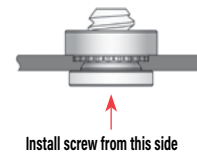
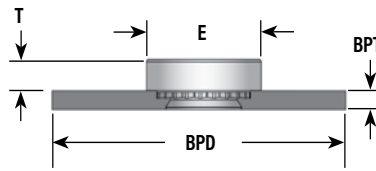

## STANDARD NUTS

All dimensions are in inches.

UNIFIED	Thread Size	Type and Material		Thread Code	Shank Code	BPD ±.0165	BPT ±.004	E ±.010	T ±.010
		Steel	Stainless Steel						
	.112-40 (#4-40)	VM20S	VMC20SP	440	1	.787	.048	.250	.070
		VM30S	VMC30SP			1.181			
	.138-32 (#6-32)	VM20S	VMC20SP	632	1	.787	.048	.280	.070
		VM30S	VMC30SP			1.181			
	.164-32 (#8-32)	VM20S	VMC20SP	832	1	.787	.048	.310	.090
		VM30S	VMC30SP			1.181			
	.190-32 (#10-32)	VM20SS	VMC20SP	032	2	.787	.071	.340	.090
		VM30SS	VMC30SP			1.181			

All dimensions are in millimeters.

METRIC	Thread Size x Pitch	Type and Material		Thread Code	Shank Code	BPD ±0.42	BPT ±0.1	E ±0.25	T ±0.25
		Steel	Stainless Steel						
	M3 x 0.5	VM20S	VMC20SP	M3	1	20	1.2	6.35	1.5
		VM30S	VMC30SP			30			
	M4 x 0.7	VM20S	VMC20SP	M4	1	20	1.2	7.87	2
		VM30S	VMC30SP			30			
	M5 x 0.8	VM20SS	VMC20SP	M5	2	20	1.8	8.64	2
		VM30SS	VMC30SP			30			

For more information on PEM® standard nuts, see [Bulletin CL](#) on our website.

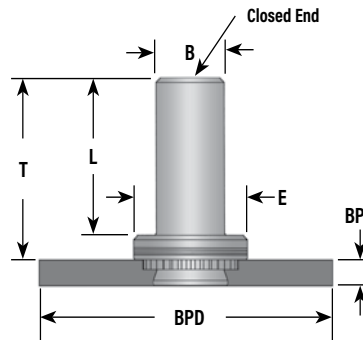

## BLIND NUTS

All dimensions are in inches.

UNIFIED	Thread Size	Type and Material	Thread Code	Shank Code	BPD ±.0165	BPT ±.004	B Max.	E ±.010	L Max.	T ±.010
		Steel								
	.112-40 (#4-40)	VM20B	440	1	.787	.048	.150	.250	.335	.380
		VM30B			1.181					
	.138-32 (#6-32)	VM20B	632	1	.787	.048	.169	.280	.335	.380
		VM30B			1.181					
	.164-32 (#8-32)	VM20B	832	1	.787	.048	.204	.310	.385	.440
		VM30B			1.181					
	.190-32 (#10-32)	VM20B	032	2	.787	.071	.235	.340	.385	.440
		VM30B			1.181					

All dimensions are in millimeters.

METRIC	Thread Size x Pitch	Type and Material	Thread Code	Shank Code	BPD ±0.42	BPT ±0.1	B Max.	E ±0.25	L Max.	T ±0.25
		Steel								
	M3 x 0.5	VM20B	M3	1	20	1.2	3.84	6.35	8.5	9.6
		VM30B			30					
	M4 x 0.7	VM20B	M4	1	20	1.2	5.2	7.95	9.8	11.2
		VM30B			30					
	M5 x 0.8	VM20B	M5	2	20	1.8	6.02	8.75	9.8	11.2
		VM30B			30					

For more information on PEM® blind nuts, see [Bulletin B](#) on our website.



Get quote >>

Angic Global Solutions

1-888-872-0690 [t.com 267](#)

<https://www.AngicGlobal.com> Sales@AngicGlobal.com

# PEM® VARIMOUNT® BONDING FASTENERS

The charts below show PEM® fastener types/sizes that are offered as standard VariMount® assemblies.

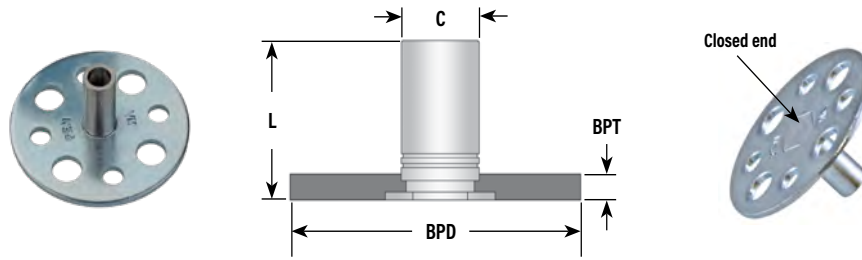

## STANDOFFS

All dimensions are in inches.

UNIFIED	Thread Size	Type and Material		Thread Code	Length Code "L" $\pm 0.002$ - $0.005$ (Length code in 32nds of an inch)						BPD $\pm 0.0165$	BPT $\pm 0.004$	C $+0.000$ - $0.005$	
		Steel			.375	.437	.500	.562	.625	.687				.750
	.112-40 (#4-40)	VM20BSO		440	12	14	16	18	20	22	24	.787	.048	.165
		VM30BSO			12	14	16	18	20	22	24	1.181		
	.138-32 (#6-32)	VM20BSO		632	12	14	16	18	20	22	24	.787	.048	.212
		VM30BSO			12	14	16	18	20	22	24	1.181		

All dimensions are in millimeters.

METRIC	Thread Size x Pitch	Type and Material		Thread Code	Length Code "L" $\pm 0.05$ - $0.13$ (Length code in millimeters)						BPD $\pm 0.42$	BPT $\pm 0.1$	C $-0.13$
		Steel			12	14	16	18	20	30			
	M3 x 0.5	VM20BSO		M3	12	14	16	18	20	30	1.2	4.2	
		VM30BSO			12	14	16	18	20	30	1.2		
	M3.5 x 0.6	VM20BSO		M3.5	12	14	16	18	20	30	1.2	5.39	
		VM30BSO			12	14	16	18	20	30	1.2		

For more information on PEM® standoffs, see [Bulletin SQ](#) on our website.

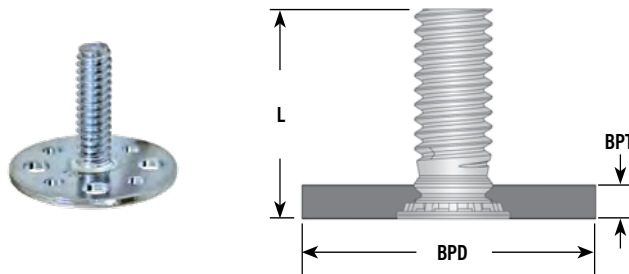

## STUDS

All dimensions are in inches.

UNIFIED	Thread Size	Type and Material		Thread Code	Length Code "L" $\pm 0.015$ (Length code in 16ths of an inch)						BPD $\pm 0.0165$	BPT $\pm 0.004$
		Steel	Stainless Steel		.500	.625	.750	.875	1.00	1.25		
	.164-32 (#8-32)	VM20FH	VMC20FHP	832	8	10	12	14	16	20	.787	.048
		VM30FH	VMC30FHP		8	10	12	14	16	20	1.181	
	.190-32 (#10-32)	VM20FH	VMC20FHP	032	8	10	12	14	16	20	.787	.048
		VM30FH	VMC30FHP		8	10	12	14	16	20	1.181	
	.250-20 (1/4-20)	VM20FH	—	0420	8	10	12	14	16	20	.787	.071
		VM30FH	—		8	10	12	14	16	20	1.181	

All dimensions are in millimeters.

METRIC	Thread Size x Pitch	Type and Material		Thread Code	Length Code "L" $\pm 0.4$ (Length code in millimeters)						BPD $\pm 0.42$	BPT $\pm 0.1$
		Steel	Stainless Steel		10	12	15	18	20	25		
	M4 x 0.7	VM20FH	VMC20FHP	M4	10	12	15	18	20	25	20	1.2
		VM30FH	VMC30FHP		10	12	15	18	20	25	30	
	M5 x 0.8	VM20FH	VMC20FHP	M5	10	12	15	18	20	25	20	1.2
		VM30FH	VMC30FHP		10	12	15	18	20	25	30	
	M6 x 1	VM20FH	—	M6	10	12	15	18	20	25	20	1.8
		VM30FH	—		10	12	15	18	20	25	30	

For more information on PEM® studs, see [Bulletin FH](#) on our website.

# PEM® VARIMOUNT® BONDING FASTENERS

## BASE PLATE PART NUMBER, DIMENSIONS AND MATERIAL GUIDE

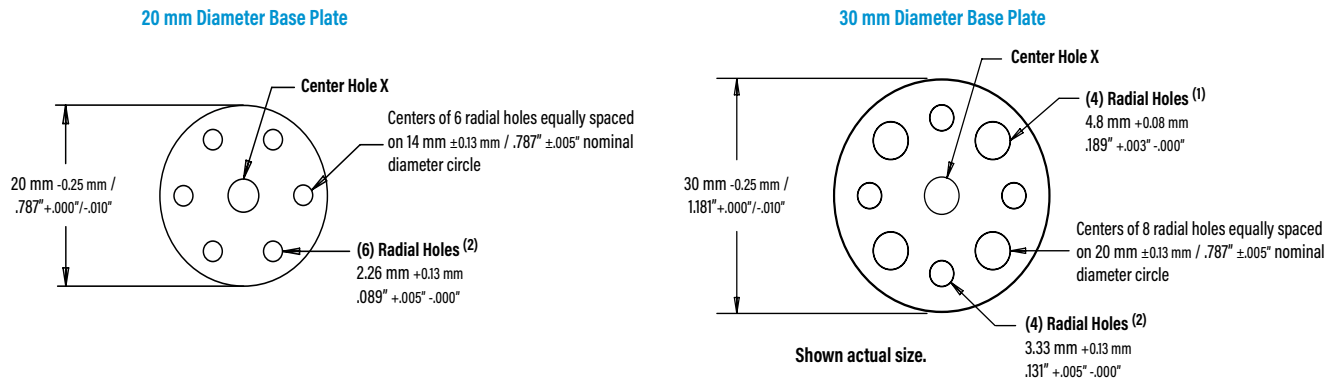

Base Plate Part Number (4)				Thickness ±0.1 mm / ±.004"	Center Hole X Diameter +0.08 mm / +.003" -.000"
Steel (5)		Stainless Steel (6)			
20 mm Dia.	30 mm Dia.	20 mm Dia.	30 mm Dia.		
BP1.2-422-20ZI	BP1.2-422-30ZI	BPC1.2-422-20	BPC1.2-422-30	1.2 mm / .048"	4.22 mm / .166"
BP1.2-480-20ZI	BP1.2-480-30ZI	BPC1.2-480-20	BPC1.2-480-30	1.2 mm / .048"	4.8 mm / .189"
BP1.2-541-20ZI	BP1.2-541-30ZI	BPC1.2-541-20	BPC1.2-541-30	1.2 mm / .048"	5.41 mm / .213"
—	BP1.6-635-30ZI	—	BPC1.6-635-30	1.6 mm / .063"	6.35 mm / .250"
BP1.2-400-20ZI	BP1.2-400-30ZI	BPC1.2-400-20	BPC1.2-400-30	1.2 mm / .048"	4 mm / .1575"
BP1.2-500-20ZI	BP1.2-500-30ZI	BPC1.2-500-20	BPC1.2-500-30	1.2 mm / .048"	5 mm / .1969"
—	BP1.6-600-30ZI	—	BPC1.6-600-30	1.6 mm / .063"	6 mm / .2362"
BP1.8-600-20ZI	—	BPC1.8-600-20	—	1.8 mm / .071"	6 mm / .2362"
BP1.8-635-20ZI	—	BPC1.8-635-20	—	1.8 mm / .071"	6.35 mm / .250"

- (1) Accepts standard M3.5 / #6-32 self-clinching nuts. Also flush-head studs #10-24 / #10-32 sizes. May also accept 4.8 mm / 3/16" rivet.
- (2) 30mm OD parts include standard holes sized for 3.2 mm / 1/8" rivets. 20mm OD parts include standard holes sized for 2 mm / 5/64" rivets
- (3) "Blank" equals steel base plate and "C" equals stainless steel base plate.
- (4) Use this part number if ordering base plate separately. Minimum quantities may apply.
- (5) Base plate is carbon steel, zinc plated per ASTM B633, SC1, Type III.
- (6) Base plate is 300 series stainless steel, passivated and/or tested per ASTM A380.

### BASE PLATE PART NUMBER DESIGNATION

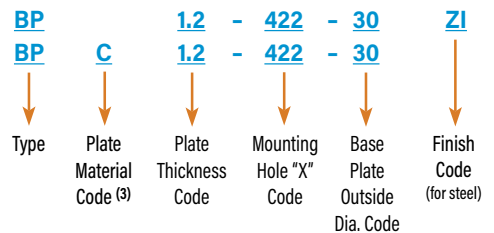

### NOTE ABOUT PERFORMANCE

General performance of PEM® fasteners in thin metal panels can be found in their respective PEM® Bulletins. Performance of the assembly (fastener and base plate) mounted to your specific material, in your application will have to be determined by testing. We recommend that you perform testing to be sure it is ideally suited to your application. We will be happy to provide technical assistance and/or samples to you for this purpose.

Look for the trademarks to identify genuine PEM® fasteners.

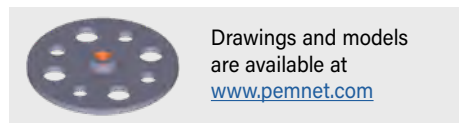
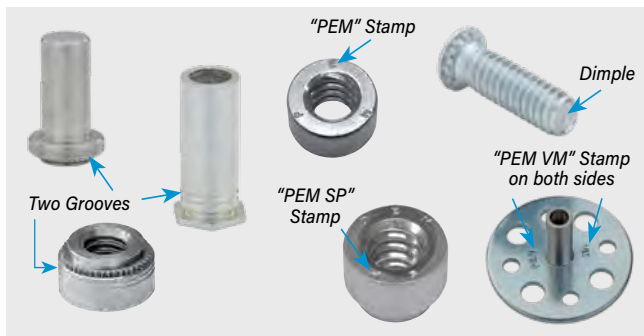

Get quote >>

Angic Global Solutions

1-888-872-0690 [www.pemnet.com](http://www.pemnet.com) 269

<https://www.AngicGlobal.com> Sales@AngicGlobal.com

# PEM® VARIMOUNT® BONDING FASTENERS

## OTHER PEM® FASTENER TYPES AND SIZES AVAILABLE \*

While we have listed the standard offering of assemblies on the charts (pages 265 and 266), other PEM® fasteners can be provided pre-installed into one of the base plates listed on page 5. The charts below give a review of these fastener types. To choose an assembly using one of these fasteners, simply create a part number as described on page 264.

PEM® Fastener Types	Standard Size Codes
<b>Self-clinching Nuts</b>	
BS	440 / 632 / 832 / 032 / M3 / M4 / M5
CLS	256 / 348 / 440 / 632 / 832 / M2 / M2.5 / M3 / M3.5 / M4
CLSS	024 / 032 / M5
LK, LKS	440 / M3
PL, PLC	M3
S	256 / 348 / M2 / M2.5 / M3.5
SL	440 / 632 / 832 / 032 / M3 / M3.5 / M4 / M5
<b>SP</b>	256 / 024
SS	024
<b>Self-clinching Studs</b>	
FH	024 / Non-threaded
<b>FH4</b>	832 / 032 / 0420 / M4 / M5 / M6
FHS	832 / 024 / 032 / 0420 M4 / M5 / M6 / Non-threaded
HFE	032 / 0420 / M5 / M6
HFH, HFHS	0420 / M6

PEM® Fastener Types	Standard Size Codes
<b>Self-clinching Standoffs</b>	
BS0, BS0S, <b>BS04</b>	440 / 632 / 6440 / M3 / 3.5M3 / M3.5
DS0, DS0S	440 / M3
SO, <b>S04</b>	6440 / 3.5M3 / M3.5 / Non-threaded
SOS	440 / 632 / 6440 / 3.5M3 / M3 / M3.5 / Non-threaded
SOSG	6440 / 3.5M3
SSC, SSS	156 / 4MM
<b>Panel Fasteners</b>	
N10	440 / 632 / 832 / M3
PF1, PF12, PF11M, PF12M	632
<b>PF11MF, PF12MF</b>	440 / M3
<b>PF11MW, PF12MW</b>	440 / M3
PF11PM	632
PF30	832
PF31, PF32	832 / M4
PF50, PF51, PF52, PF60, PF61, PF62	832 / M4
PF7M	632
<b>PF7MF</b>	440 / M3
SCB, SCBJ	M4
SCBR	832 / M4

*Types shown in bold italics can be installed into stainless steel base plates. Other types are not recommended for installation into stainless steel base plates.*



Micro Sized Options Available

\* Other fasteners, base plate configurations and assemblies are available on special order. For questions, please contact our global technical support team using the contact information listed at the bottom of this page. Appropriate minimum quantities may apply.



PEM® brand self-locating weld nuts feature engineered projections, round head design and a self-locating shank



**WN™**

## SELF-LOCATING PROJECTION WELD NUTS

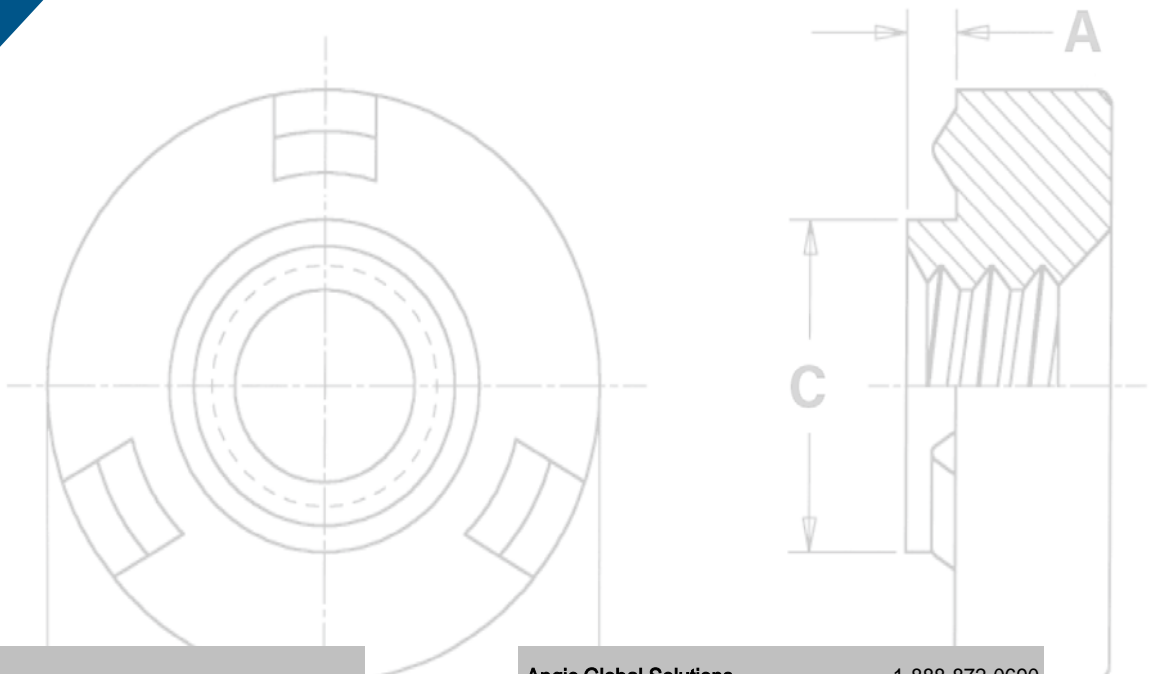

Get quote »

Angic Global Solutions

1-888-872-0690

<https://www.AngicGlobal.com> [Sales@AngicGlobal.com](mailto:Sales@AngicGlobal.com)

# SELF-LOCATING PROJECTION WELD NUTS

PEM® brand WN™/WNS™ weld nuts are designed to be welded onto another metal surface into properly sized holes. The PEM® weld nut design helps overcome many problems associated with other welded nuts:

- **Engineered projections**
  - Prevent burn-outs in thin sheets
  - Help keep the nut from warping while welding in high current
- **Round head design**
  - Eliminates tedious time-consuming indexing
  - Speeds production using standard equipment
  - Compact design fits on narrow flanges
- **Self-locating shank**
  - Eliminates the need for complex electrodes with pilots
  - Properly positions weld nuts
  - Protects threads from weld spatter

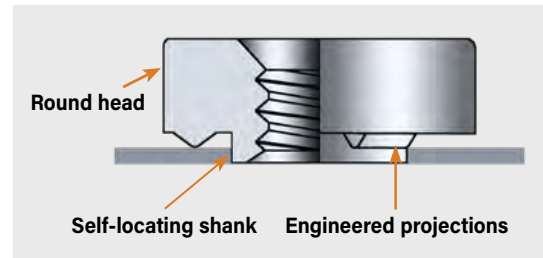

A variety of welding equipment is suitable for installation of PEM® weld nuts. Best results have been obtained with a 50KVA press-type, spot-welding machine whose upper welding head moves vertically in a straight line with the lower electrode. Flat-faced electrodes with tip diameters .125" / 3.2 mm larger than the "E" dimension of the PEM® weld nut should be used.

PEM® weld nuts are available in steel (WN™) or stainless steel (WNS™). Stainless steel nuts offer the added advantage of corrosion resistance.

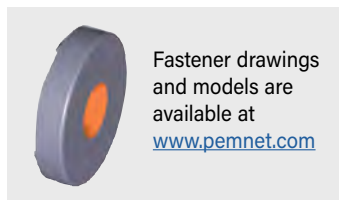
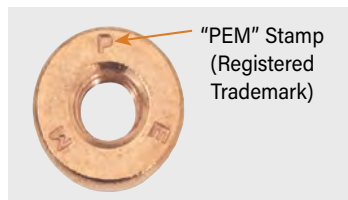

# SELF-LOCATING PROJECTION WELD NUTS

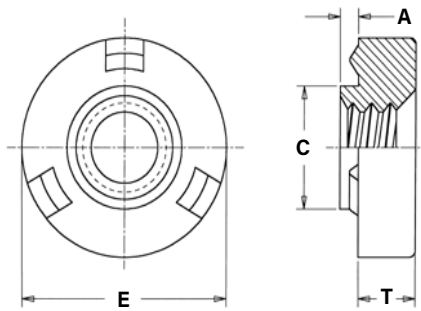

## PART NUMBER DESIGNATION

**WN** - **632** - **0** **CU**  
**WN** **S** - **632** - **0**

↓      ↓                      ↓                      ↓                      ↓  
 Type   Material              Thread              Shank              Finish  
          Code                      Size Code              Code

All dimensions are in inches.

UNIFIED	Thread Size	Type		Thread Code	Shank Code	A (Shank) Max.	Min. Sheet Thickness	Hole Size In Sheet +.004 -.000	C Max.	E +.000 -.010	T ±.004	Min. Dist. Hole To Edge
		Steel	Stainless Steel									
	.112-40 (#4-40)	WN	WNS	440	0	.030	.030	.173	.172	.308	.065	.154
	.138-32 (#6-32)	WN	WNS	632	0	.030	.030	.193	.192	.341	.094	.171
	.164-32 (#8-32)	WN	WNS	832	0	.030	.030	.218	.217	.371	.108	.186
	.190-24 (#10-24)	WN	WNS	024	0	.030	.030	.250	.249	.440	.156	.220
	.190-32 (#10-32)	WN	WNS	032	0	.030	.030	.250	.249	.440	.156	.220
	.250-20 (1/4-20)	WN	WNS	0420	0	.048	.048	.316	.315	.522	.186	.261

All dimensions are in millimeters.

METRIC	Thread Size x Pitch	Type		Thread Code	Shank Code	A (Shank) Max.	Min. Sheet Thickness	Hole Size In Sheet +0.1	C Max.	E -0.25	T ±0.1	Min. Dist. Hole To Edge
		Steel	Stainless Steel									
	M3 x 0.5	WN	WNS	M3	0	0.77	0.77	4.39	4.36	7.82	1.49	3.91
	M4 x 0.7	WN	WNS	M4	0	0.77	0.77	5.53	5.5	9.42	2.58	4.71
	M5 x 0.8	WN	WNS	M5	0	0.77	0.77	6.35	6.32	11.17	3.78	5.59
	M6 x 1	WN	WNS	M6	0	1.22	1.24	8.04	8.01	13.25	4.56	6.63

## MATERIAL AND FINISH SPECIFICATIONS

Type	Threads	Fastener Materials		Standard Finishes	
	Internal, ASME B1.1, 2B/ ASME B1.13M, 6H	Carbon Steel	300 Series Stainless Steel	Passivated and/or Tested Per ASTM A380	Copper Flash (1)
WN	■	■	■	■	■
WNS	■		■	■	
Part Number Code For Finishes				None	CU

(1) Copper Flash plating prevents surface rust, facilitates automatic feeding, and requires no preparation before painting or finishing.

## INSTALLATION

- With a PEM® weld nut inserted in the properly sized hole (see above), bring the electrode force up sufficiently to clamp the projections of the fastener firmly against the sheet without embedding any portion of the projections. Be sure the electrodes are centered, and that the electrode faces are flat so that the force is applied evenly to all three projections.
- Set the current or heat regulator on the low side and adjust along with the weld time until a good weld is produced. For mild steel, which has a medium electrical resistance, there is a wide range of adjustments possible. For austenitic stainless steel, which has a high electrical resistance, the range is narrow at low heat.
- Adjust squeeze time so that there is adequate time for the electrodes to close and develop proper forces (suggested initial setting 35 cycles). The weld period should be established by starting with the settings suggested in the tables on page 4. As indicated above for current adjustments, a wide range of time is possible with mild steel, but there is a limited range with stainless steel. If weld time starts too soon, and proper welding is not achieved, the squeeze time should be lengthened. Also, the electrodes should be moved closer together so that they require less travel time to close on the work. Longer squeeze times will have no effect on the quality of the weld. However, they do affect productivity and decrease the number of weld nuts that can be installed per hour. Hold time is set long enough to permit cooling and solidification of the weld before removing the electrodes. Start with 15 cycles and lengthen if necessary.



Get quote »

Angic Global Solutions

1-888-872-0690 [www.angic.com](http://www.angic.com) 273

<https://www.AngicGlobal.com> Sales@AngicGlobal.com

# SELF-LOCATING PROJECTION WELD NUTS

## PERFORMANCE DATA<sup>(1)</sup>

UNIFIED	Type	Thread Code	Test Sheet Material			
			.060" Cold-rolled Steel		.060" 302 Stainless Steel	
			Pushout (lbs.)	Torque-out (in. lbs.)	Pushout (lbs.)	Torque-out (in. lbs.)
WN	440	500	13	N/A	N/A	
	632	640	22	N/A	N/A	
	832	760	33	N/A	N/A	
	032	880	56	N/A	N/A	
	0420	1000	185	N/A	N/A	
WNS	440	N/A	N/A	680	13	
	632	N/A	N/A	800	28	
	832	N/A	N/A	850	45	
	032	N/A	N/A	900	110	
	0420	N/A	N/A	1000	200	

METRIC	Type	Thread Code	Test Sheet Material			
			1.5 mm Cold-rolled Steel		1.5 mm 302 Stainless Steel	
			Pushout (N)	Torque-out (N-m)	Pushout (N)	Torque-out (N-m)
WN	M3	2220	1.4	N/A	N/A	
	M4	3380	3.7	N/A	N/A	
	M5	3910	6.3	N/A	N/A	
	M6	4445	20.9	N/A	N/A	
	M3	N/A	N/A	3020	1.4	
WNS	M4	N/A	N/A	3780	5	
	M5	N/A	N/A	4000	12.4	
	M6	N/A	N/A	4445	22.5	

## SETTING GUIDES FOR PEM® WELD NUTS IN .030"/0.77 MM TO .063"/1.6 MM SHEETS

UNIFIED	Type	Thread Code	Test Sheet Material					
			Cold-rolled Steel			302 Stainless Steel		
			Electrode <sup>(A)</sup> Ram Force (lbs.)	Secondary <sup>(B)</sup> Current Amps ±500	Weld <sup>(C)</sup> Time Cycles/Sec.	Electrode <sup>(A)</sup> Ram Force (lbs.)	Secondary <sup>(B)</sup> Current Amps ±500	Weld <sup>(C)</sup> Time Cycles/Sec.
WN	440	450-500	17,000	6 / 0.10	N/A	N/A	N/A	
	632	450-500	17,000	6 / 0.10	N/A	N/A	N/A	
	832	450-500	17,000	6 / 0.10	N/A	N/A	N/A	
	032	500-550	18,000	10 / 0.17	N/A	N/A	N/A	
	0420	550-600	20,000	10 / 0.17	N/A	N/A	N/A	
WNS	440	N/A	N/A	N/A	450-500	16,500	6 / 0.10	
	632	N/A	N/A	N/A	450-500	16,500	6 / 0.10	
	832	N/A	N/A	N/A	500-550	16,500	6 / 0.10	
	032	N/A	N/A	N/A	550-600	18,500	6 / 0.10	
	0420	N/A	N/A	N/A	650-700	20,000	6 / 0.10	

METRIC	Type	Thread Code	Test Sheet Material					
			Cold-rolled Steel			302 Stainless Steel		
			Electrode <sup>(A)</sup> Ram Force (N)	Secondary <sup>(B)</sup> Current Amps ±500	Weld <sup>(C)</sup> Time Cycles/Sec.	Electrode <sup>(A)</sup> Ram Force (N)	Secondary <sup>(B)</sup> Current Amps ±500	Weld <sup>(C)</sup> Time Cycles/Sec.
WN	M3	2000-2220	17,000	6 / 0.10	N/A	N/A	N/A	
	M4	2000-2220	17,000	6 / 0.10	N/A	N/A	N/A	
	M5	2220-2440	18,000	10 / 0.17	N/A	N/A	N/A	
	M6	2440-2670	20,000	10 / 0.17	N/A	N/A	N/A	
	M3	N/A	N/A	N/A	2000-2220	16,500	6 / 0.10	
WNS	M4	N/A	N/A	N/A	2220-2440	16,500	6 / 0.10	
	M5	N/A	N/A	N/A	2440-2670	18,500	6 / 0.10	
	M6	N/A	N/A	N/A	2890-3110	20,000	6 / 0.10	

N/A Not Applicable.

- (1) Published installation forces are for general reference. Actual set-up and confirmation of complete installation should be made by observing proper seating of fastener as described in the installation steps. Other performance values reported are averages when all proper installation parameters and procedures are followed. Variations in mounting hole size, sheet material, and installation procedure may affect performance. Performance testing this product in your application is recommended. We will be happy to provide technical assistance and/or samples for this purpose.
- (A) **Electrode Force** is the force exerted by the electrodes on the fastener and sheet to clamp them together and ensure good electrical contact. Electrode force also sets the weld nut down flush on the sheet as the projections melt during the welding period. Insufficient electrode force may result in flashing, spitting, burning, spatter, and discoloration. On the other hand, excessive electrode force may flatten the fastener projections before proper welding temperature is reached or may embed the projections of the cold fastener into the sheet. Excessive electrode force can also distort threads during the weld cycle.
- (B) **Secondary Current** determines the heat applied to the PEM® weld nut and sheet. Heat is in direct proportion to weld time, resistances of the materials, and the square of the current. Current should not be set so high as to cause flashing or spattering or excessive heat which will distort the threads. Low currents may produce good looking welds but pushout and torque-out strengths will not be satisfactory.
- (C) **Timing Cycle** for projection welding comprises four periods; 1) the squeeze time in which the electrodes move into position and develop the required force; 2) the weld time when the current is applied; 3) the hold time while the weld congeals and cools; and 4) the off time for positioning the work for the next weld nut.

**NOTE: The setting guides shown in the above charts are for reference only and may differ for your welding equipment.**

*Axial Strength and Mating Screw Recommended Tightening Torque data is available at: [www.pemnet.com/design\\_info/tightening-torque/](http://www.pemnet.com/design_info/tightening-torque/)*

## GUIDES TO BETTER WELDING

Electrodes, weld nuts, and panels must be clean and free of grease, rust, and metal burrs. When welds appear satisfactory on installed nut, but pushout values are low, one or more of the following may be the cause:

- 1) Ram pressure too high.
- 2) Current too low.
- 3) Panel not clean.
- 4) Weld nuts not centered under electrodes.
- 5) Hold time not long enough to allow proper cooling.
- 6) Pressure regulator on welding equipment drifts.

If installed threads are distorted, one or more of the following may be the cause:

- 1) Weld time too long.
- 2) Current too high.
- 3) Ram pressure too high.

Should it be impossible to produce a proper weld because weld time starts before electrodes close on the work, shorten the gap between the electrodes so that they take less time to move into position and/or lengthen the squeeze time.

All PEM® products meet our stringent quality standards. If you require additional industry or other specific [quality certifications](#), special procedures and/or part numbers are required. Please contact your local sales office or representative for further information.

Regulatory [compliance information](#) is available in Technical Support section of our website. Specifications subject to change without notice. See our website for the most current version of this bulletin.

**PennEngineering®**



**North America:** Danboro, Pennsylvania USA ▪ E-mail: [info@pemnet.com](mailto:info@pemnet.com) ▪ Tel: +1-215-766-8853 ▪ 800-237-4736 (USA)

**Europe:** Galway, Ireland ▪ E-mail: [europa@pemnet.com](mailto:europa@pemnet.com) ▪ Tel: +353-91-751714

**Asia/Pacific:** Singapore ▪ E-mail: [singapore@pemnet.com](mailto:singapore@pemnet.com) ▪ Tel: +65-6-745-0660

Shanghai, China ▪ E-mail: [china@pemnet.com](mailto:china@pemnet.com) ▪ Tel: +86-21-5868-3688

Visit our PEMNET™ Resource Center at [www.pemnet.com](http://www.pemnet.com) ▪ Technical support e-mail: [techsupport@pemnet.com](mailto:techsupport@pemnet.com)

Revised



Get quote »

Angic Global Solutions

1-888-872-0690

<https://www.AngicGlobal.com> Sales@AngicGlobal.com