

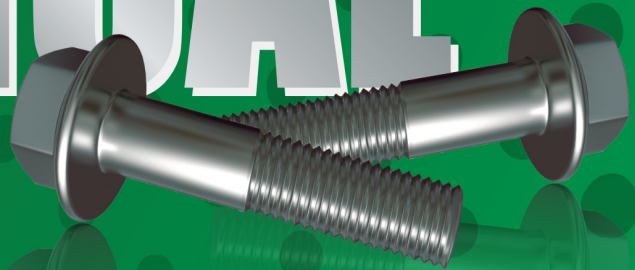

BY ANY MEASURE.

TECHNICAL MANUAL

the distributor's choice



**THE DEFINITIVE GUIDE THE INDUSTRY'S WIDEST AND DEEPEST
SELECTION OF METRIC, STANDARD AND SPECIAL FASTENERS**



Get quote »

Angic Global Solutions

1-888-872-0690

<https://www.AngicGlobal.com> Sales@AngicGlobal.com

Value Advantage

Lindstrom's Quality Policy is based on customer satisfaction. We strive for continuous improvement in our quality systems, to the objectives of our company:

- Supplying products that meet or exceed our customer's requirements
- Providing a service that results in customer satisfaction
- Continuous development of a dependable vendor base

We are committed to the pursuit of continuous improvement in quality and the assessment of the quality system in order to assure its sustainability to meet the requirements of our company and the requirements of our customers.



CONVENIENCE. VALUE. FLEXIBILITY. CHOICE.

The true value of an industry partner is realized when they transcend the boundaries of 'traditional supplier' - becoming an invaluable resource, rather than just a parts source.



**METRIC AND
STANDARD INCH
SERIES FASTENERS**



**CUSTOM
PACKAGING
SOLUTIONS**



**SPECIAL PLATING
AND SECONDARY
PROCESSES**



**MANUFACTURED
PARTS AND
CNC SPECIALS**



**TECHNICAL
SERVICES AND
SUPPORT NETWORK**



**VENDOR
MANAGED
PROGRAMS**

WELCOME TO THE NEW LINDSTROM.



Metric Products

PRODUCT	STANDARD	SIMILAR/COMPARISON STANDARD		SECTION	PAGE
SOCKET HEAD CAP SCREWS	DIN 912	ISO 4762	ANSI B 18.3.1 M	-	1.1-3 4
FLANGE SOCKET HEAD CAP SCREWS	-	-	-	-	1.4 7
SOCKET HEAD CAP SCREWS WITH SERRATED FLANGE	-	-	-	-	1.4 7
LOW HEAD SOCKET CAP SCREWS WITH PILOT	DIN 6912	-	-	-	1.5 8
LOW HEAD SOCKET CAP SCREWS	DIN 7984	-	-	-	1.5 8
SOCKET SHOULDER (STRIPPER) BOLTS	ISO 7379	-	ANSI B 18.3.3 M	-	1.6 9
BUTTON HEAD SOCKET CAP SCREWS	ISO 7380	-	ANSI B 18.3.4 M	-	1.7 10
FLAT SOCKET HEAD CAP SCREWS	DIN 7991	ISO 10642	ANSI B 18.3.5 M	-	1.8 11
SOCKET SET SCREWS FLAT POINT	DIN 913	ISO 4026	ANSI B 18.3.6 M	-	1.9 12
SOCKET SET SCREWS CONE POINT	DIN 914	ISO 4027	ANSI B 18.3.6 M	-	1.10 13
SOCKET SET SCREWS DOG POINT	DIN 915	ISO 4028	ANSI B 18.3.6 M	-	1.11 14
SOCKET SET SCREWS CUP POINT	DIN 916	ISO 4029	ANSI B 18.3.6 M	-	1.12 15
HEX KEYS	ISO 2936	-	ANSI B 18.3.2 M	-	1.13 16
HEX HEAD CAP SCREWS (COARSE PITCH)	DIN 931/933	ISO 4014/4017	ANSI B 18.2.3 M	JIS B 1180	2.1-3 17
HEX HEAD CAP SCREWS (FINE PITCH)	DIN 960/961	ISO 8765/8676	-	JIS B 1180	2.4-5 20
HEX HEAD FLANGE SCREWS	DIN 6921	IFI 536	ASME-ANSI B18.2.3.4M	JIS B 1189	2.6-7 22
RIBBED FLANGE SCREWS	-	-	-	-	2.8 24
SERRATED FLANGE SCREWS	-	-	-	-	2.8 24
FULL HEX NUTS	DIN 934	ISO 4032 STYLE 1	ANSI B 18.2.4.1M STYLE 1	JIS B1181	3.1-3 25
HEX JAM NUTS	DIN 439 B	ISO 4035/8675	ANSI B 18.2.4.5 M	-	3.4-5 28
NYLON INSERT LOCK NUTS	DIN 985	ISO 7040	ANSI B 18.16.3M	-	3.6-7 30
ALL-METAL LOCK NUTS	DIN 980	ISO 7719	ANSI B 18.16.3M	-	3.8-9 32
HEX NUTS WITH WASHERS ATTACHED (KEPS®)	-	-	-	-	3.10 34
HEX FLANGE NUTS	DIN 6923	ISO 4161	ANSI B 18.2.4.4M	JIS B 1190	3.11 35
HEX NUTS WITH CONICAL SPRING WASHERS ATTACHED	-	-	-	-	3.12 36
HEX COUPLING NUTS	DIN 6334	-	-	-	3.12 36
SQUARE WELD NUTS	DIN 928	-	-	-	3.13 37
HEX WELD NUTS	DIN 929	-	-	-	3.13 37
CARRIAGE BOLTS	DIN 603	ISO 8677/8678	ASME B 18.5.2.1M	-	4.1-2 38
LIFTING EYE BOLTS	DIN 580	-	-	-	4.3 40
LIFTING EYE NUTS	DIN 582	-	-	-	4.4 41
SLOTTED CHEESE HEAD MACHINE SCREWS	DIN 84	ISO 1207	-	-	5.1 42
PHILLIPS CHEESE HEAD MACHINE SCREWS	-	ISO 7048	-	SN 213307	5.2 43
SLOTTED PAN HEAD MACHINE SCREWS	DIN 85	ISO 1580	ANSI B 18.16.7 M	JIS B 1101	5.3 44
PHILLIPS PAN HEAD MACHINE SCREWS	DIN 7985	ISO 7045	ANSI B 18.16.7 M	JIS B 1111	5.4 45
SLOTTED FLAT HEAD MACHINE SCREWS	DIN 963	ISO 2009	ANSI B 18.16.7 M	JIS B 1101	5.5 46
PHILLIPS FLAT HEAD MACHINE SCREWS	DIN 965	ISO 7046	ANSI B 18.16.7 M	JIS B 1111	5.6 47
SLOTTED OVAL HEAD MACHINE SCREWS	DIN 964	ISO 2010	ANSI B 18.16.7 M	JIS B 1101	5.7 48
PHILLIPS OVAL HEAD MACHINE SCREWS	DIN 966	ISO 7047	ANSI B 18.16.7 M	JIS B 1111	5.8 49
STUDS	DIN 939	-	-	-	6.1 50
FLAT WASHERS (REGULAR SERIES)	DIN 125A/B	ISO 7089/7090	-	-	7.1 51
FLAT WASHERS (SMALL SERIES)	DIN 433	ISO 7092	-	-	7.2 52
FLAT WASHERS (LARGE SERIES)	DIN 9021	ISO 7093	-	-	7.3 53
SPLIT LOCK WASHERS	DIN 127B	-	-	-	7.4 54
SPLIT LOCK WASHERS (HIGH COLLAR)	DIN 7980	-	-	-	7.4 54
EXTERNAL TOOTH LOCK WASHERS	DIN 6797 A	-	-	-	7.5 55
INTERNAL TOOTH LOCK WASHERS	DIN 6797 J	-	-	-	7.5 55
EXTERNAL TOOTH SERRATED LOCK WASHERS	DIN 6798 A	-	-	-	7.5 55
INTERNAL TOOTH SERRATED LOCK WASHERS	DIN 6798 J	-	-	-	7.5 55
EXTERNAL TOOTH COUNTERSUNK SERRATED LOCK WASHERS	DIN 6798 V	-	-	-	7.5 55

LFG 10-01-2016 REVISED



PRODUCT INDEX



Metric Products continued

PRODUCT INDEX - METRIC & INCH

PRODUCT	STANDARD	SIMILAR/COMPARISON STANDARD			SECTION	PAGE
EXTERNAL RETAINING RINGS	DIN 471	-	-	-	7.6	56
INTERNAL RETAINING RINGS	DIN 472	-	-	-	7.6	56
E SERIES EXTERNAL CLIPS	DIN 6799	-	-	-	7.6	56
DOWEL PINS	DIN 6325	ISO 8734A	-	-	8.1	57
TAPER PINS	DIN 1B	ISO 2339B	-	-	8.2	58
THREAD FORMING & THREAD CUTTING SCREWS	DIN 7500	-	-	-	9.1	59
GENERAL INFORMATION FOR METRIC FASTENERS	-	-	-	-	10.1	60
THREAD PITCHES & PREFERENCE CLASSES	-	-	-	-	10.2	61
MECHANICAL PROPERTIES FOR BOLTS & SCREWS	-	-	-	-	10.3	62
TORQUE VALUES	-	-	-	-	10.4	63
TABLE OF WEIGHTS	-	-	-	-	11.1-13	64

LFG 10-01-2016 REVISED



Inch Products

PRODUCT	STANDARD	SECTION	PAGE
SOCKET HEAD CAP SCREWS	ASME B18.3	12.1	78
SOCKET HEAD SHOULDER (STRIPPER) BOLTS	ASME B18.3	12.2	79
BUTTON HEAD SOCKET CAP SCREWS	ASME B18.3	12.3	80
FLAT SOCKET HEAD CAP SCREWS	ASME B18.3	12.4	81
HEX HEAD CAP SCREWS (COARSE PITCH)	ASME B18.2.1	13.1	82
FULL HEX NUTS	ASME B18.2.2	14.1	83
NYLON INSERT LOCK NUTS (NM)	ASME B18.16.6	14.2	84
NYLON INSERT LOCK NUTS (NTM)	ASME B18.16.6	14.2	84
NYLON INSERT LOCK NUTS (NE)	ASME B18.16.6	14.3	85
NYLON INSERT LOCK NUTS (NTE)	ASME B18.16.6	14.3	85
NYLON INSERT LOCK NUTS (NU)	ASME B18.16.6	14.4	86
NYLON INSERT LOCK NUTS (NTU)	ASME B18.16.6	14.4	86
USS FLAT WASHERS	ASME B18.21.1	15.1	87
SAE FLAT WASHERS	ASME B18.21.1	15.1	87
HELICAL SPRING LOCK WASHERS	ASME B18.21.1	15.1	87
MACHINE BUSHINGS	ASTM F844	15.2	88
EXTERNAL RETAINING RINGS (TYPE SH)	ASME B18.27.1-NA1	15.3	89
INTERNAL RETAINING RINGS (TYPE HO)	ASME B18.27.1-NA2	15.3	89
EXTERNAL TYPE E CLIPS	ASME B18.27.1-NA3	15.3	89
TRILOBULAR THREAD FORMING SCREWS	THREAD DIMENSIONS /CONFIGURATIONS	16.1	90
TYPE 23 THREAD CUTTING SCREWS	THREAD DIMENSIONS /CONFIGURATIONS	16.2	91
TYPE 25 THREAD CUTTING SCREWS	THREAD DIMENSIONS /CONFIGURATIONS	16.3	92
TYPE F THREAD CUTTING SCREWS	THREAD DIMENSIONS /CONFIGURATIONS	16.4	93
PAN HEAD & TRUSS HEAD SCREWS	HEAD / DRIVE DIMENSIONS TO ASME B18.6.3	16.5	94
FLAT HEAD & FLAT HEAD UNDERCUT SCREWS	HEAD / DRIVE DIMENSIONS TO ASME B18.6.3	16.6	95
HEX HEAD / HEX WASHER HEAD & COMBO HEAD SCREWS	HEAD / DRIVE DIMENSIONS TO ASME B18.6.3	16.7	96
ROUND HEAD & ROUND HEAD SCREWS WITH WASHER	HEAD / DRIVE DIMENSIONS TO ASME B18.6.3	16.8	97
OVAL HEAD SCREWS	HEAD / DRIVE DIMENSIONS TO ASME B18.6.3	16.9	98
OVAL HEAD UNDERCUT SCREWS	HEAD / DRIVE DIMENSIONS TO ASME B18.6.3	16.10	99

LFG 10-01-2016 REVISED



Get quote »

Angic Global Solutions

1-888-872-0690 Rights Reserved

<https://www.AngicGlobal.com> Sales@AngicGlobal.com



BY ANY MEASURE.

Metric Products

THE DISTRIBUTOR'S CHOICE WITH THE INDUSTRY'S WIDEST AND DEEPEST



Get quote >>

STANDARD

Angic Global Solutions

1-888-872-0690

<https://www.AngicGlobal.com> Sales@AngicGlobal.com

SOCKET HEAD CAP SCREWS - DIN 912 / ISO 4762 / ANSI B 18.3.1 M

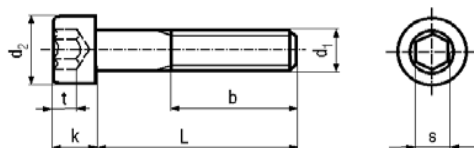

Head Diameter d2 max. allows for Knurled Head

For Screws Not Fully Threaded, The Thread Length Shown Is Minimum

1.1 - SOCKET HEAD CAP SCREWS

Thread Size d1	(M1.4)		M1.6		M2		M2.5		M2.6		M3		M4	
Thread Pitch	0.3		0.35		0.4		0.45		0.45		0.5		0.7	
Thread Length b	Full Thread		Full Thread		Full Thread		Full Thread		Full Thread		25mm & Longer 18mm		30mm & Longer 20mm	
Head Dia. d2	min.	max.	min.	max.	min.	max.	min.	max.	min.	max.	min.	max.	min.	max.
DIN 912 (1983)	2.46	2.74	2.86	3.14	3.62	3.98	4.32	4.68	4.82	5.18	5.32	5.68	6.78	7.22
ISO 4762 (1997)			2.86	3.14	3.62	3.98	4.32	4.68			5.32	5.68	6.78	7.22
ANSI B 18.3.1 M (1986)			2.87	3.00	3.65	3.80	4.33	4.50			5.32	5.50	6.80	7.00
Head Height k	min.	max.	min.	max.	min.	max.	min.	max.	min.	max.	min.	max.	min.	max.
DIN 912 (1983)	1.26	1.40	1.46	1.60	1.86	2.00	2.36	2.50	2.46	2.60	2.86	3.00	3.82	4.00
ISO 4762 (1997)			1.46	1.60	1.86	2.00	2.36	2.50			2.86	3.00	3.82	4.00
ANSI B 18.3.1 M (1986)			1.52	1.60	1.91	2.00	2.40	2.50			2.89	3.00	3.88	4.00
Key Size nominal s	1.3		1.5		1.5		2		2		2.5		3	
DIN 912 (1983)	min.	max.	min.	max.	min.	max.	min.	max.	min.	max.	min.	max.	min.	max.
ISO 4762 (1997)	1.320	1.360	1.520	1.560	1.520	1.560	2.020	2.060	2.020	2.060	2.520	2.580	3.020	3.080
ANSI B 18.3.1 M (1986)			1.520	1.545	1.520	1.545	2.020	2.045			2.520	2.560	3.020	3.071
Key Engagement t	min.		min.		min.		min.		min.		min.		min.	
DIN 912 (1983)	0.60		0.70		1.00		1.10		1.20		1.30		2.00	
ISO 4762 (1997)			0.70		1.00		1.10				1.30		2.00	
ANSI B 18.3.1 M (1986)			0.80		1.00		1.25				1.50		2.00	
Thread Size d1	M5		M6		M8		M10		M12		(M14)		M16	
Thread Pitch	0.8		1		1.25		1.5		1.75		2		2	
Thread Length b	30mm & Longer 22mm		35mm & Longer 24mm		40mm & Longer 28mm		45mm & Longer 32mm		55mm & Longer 36mm		60mm & Longer 40mm		65mm & Longer 44mm	
Head Dia. d2	min.	max.	min.	max.	min.	max.	min.	max.	min.	max.	min.	max.	min.	max.
DIN 912 (1983)	8.28	8.72	9.78	10.22	12.73	13.27	15.73	16.27	17.73	18.27	20.67	21.33	23.67	24.33
ISO 4762 (1997)	8.28	8.72	9.78	10.22	12.73	13.27	15.73	16.27	17.73	18.27	20.67	21.33	23.67	24.33
ANSI B 18.3.1 M (1986)	8.27	8.50	9.74	10.00	12.70	13.00	15.67	16.00	17.63	18.00	20.60	21.00	23.58	24.00
Head Height k	min.	max.	min.	max.	min.	max.	min.	max.	min.	max.	min.	max.	min.	max.
DIN 912 (1983)	4.82	5.00	5.70	6.00	7.64	8.00	9.64	10.00	11.57	12.00	13.57	14.00	15.57	16.00
ISO 4762 (1997)	4.82	5.00	5.70	6.00	7.64	8.00	9.64	10.00	11.57	12.00	13.57	14.00	15.57	16.00
ANSI B 18.3.1 M (1986)	4.86	5.00	5.85	6.00	7.83	8.00	9.81	10.00	11.79	12.00	13.77	14.00	15.76	16.00
Key Size nominal s	4		5		6		8		10		12		14	
DIN 912 (1983)	min.	max.	min.	max.	min.	max.	min.	max.	min.	max.	min.	max.	min.	max.
ISO 4762 (1997)	4.020	4.095	5.020	5.140	6.020	6.140	8.025	8.175	10.025	10.175	12.032	12.212	14.032	14.212
ANSI B 18.3.1 M (1986)	4.020	4.084	5.020	5.084	6.020	6.095	8.025	8.115	10.025	10.127	12.032	12.146	14.032	14.159
Key Engagement t	min.		min.		min.		min.		min.		min.		min.	
DIN 912 (1983)	2.5		3.0		4.0		5.0		6.0		7.0		8.0	
ISO 4762 (1997)	2.5		3.0		4.0		5.0		6.0		7.0		8.0	
ANSI B 18.3.1 M (1986)	2.5		3.0		4.0		5.0		6.0		7.0		8.0	
Thread Size d1	(M18)		M20		(M22)		M24		(M27)		M30		M33	
Thread Pitch	2.5		2.5		2.5		3		3		3.5		3.5	
Thread Length b	70mm & Longer 48mm		80mm & Longer 52mm		80mm & Longer 56mm		90mm & Longer 60mm		100mm & Longer 66mm		110mm & Longer 72mm		110mm & Longer 78mm	
Head Dia. d2	min.	max.	min.	max.	min.	max.	min.	max.	min.	max.	min.	max.	min.	max.
DIN 912 (1983)	26.67	27.33	29.67	30.33	32.61	33.39	35.61	36.39	39.61	40.39	44.61	45.39	49.61	50.39
ISO 4762 (1997)			29.67	30.33			35.61	36.39			44.61	45.39		
ANSI B 18.3.1 M (1986)			29.53	30.00			35.48	36.00			44.42	45.00		
Head Height k	min.	max.	min.	max.	min.	max.	min.	max.	min.	max.	min.	max.	min.	max.
DIN 912 (1983)	17.57	18.00	19.48	20.00	21.48	22.00	23.48	24.00	26.48	27.00	29.48	30.00	32.38	33.00
ISO 4762 (1997)			19.48	20.00			23.48	24.00			29.48	30.00		
ANSI B 18.3.1 M (1986)			19.73	20.00			23.70	24.00			29.67	30.00		
Key Size nominal s	14		17		17		19		19		22		24	
DIN 912 (1983)	min.	max.	min.	max.	min.	max.	min.	max.	min.	max.	min.	max.	min.	max.
ISO 4762 (1997)	14.032	14.212	17.050	17.230	17.050	17.230	19.065	19.275	19.065	19.275	22.065	22.275	24.065	24.275
ANSI B 18.3.1 M (1986)			17.050	17.216			19.065	19.243			22.065	22.319		
Key Engagement t	min.		min.		min.		min.		min.		min.		min.	
DIN 912 (1983)	9.0		10.0		11.0		12.0		13.5		15.5		18.0	
ISO 4762 (1997)			10.0				12.0				15.5			
ANSI B 18.3.1 M (1986)			10.0				12.0				15.0			

FOR MORE DETAILED INFORMATION, PLEASE REFER TO COMPLETE DIN, ISO, OR ANSI STANDARD, WHICH ARE THE GOVERNING STANDARDS

DIN 912 (1983) / ISO 4762 (1997) / ANSI B 18.3.1M (1986) - LFG 10/01/10 REVISED



Get quote >>

Angic Global Solutions

1-888-872-0690 Rights Reserved

<https://www.AngicGlobal.com> Sales@AngicGlobal.com

SOCKET HEAD CAP SCREWS • DIN 912 / ISO 4762 / ANSI B 18.3.1 M

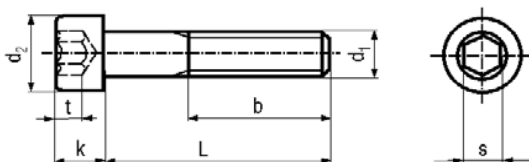

Head Diameter d2 max. allows for Knurled Head

For Screws Not Fully Threaded, The Thread Length Shown Is Minimum

Thread Size d1	M36		(M39)		M42		(M45)		M48		M56		M64	
Thread Pitch	4		4		4.5		4.5		5		5.5		6	
Thread Length b	120mm & Longer 84mm		120mm & Longer 84mm		140mm & Longer 96mm		140mm & Longer 96mm		160mm & Longer 108mm		180mm & Longer 124mm		200mm & Longer 140mm	
Head Dia. d2	min.	max.	min.	max.	min.	max.	min.	max.	min.	max.	min.	max.	min.	max.
DIN 912 (1983)	53.54	54.46	57.54	58.46	62.54	63.46	66.54	67.46	71.54	72.46	83.46	84.54	95.46	96.54
ISO 4762 (1997)	53.54	54.46			62.54	63.46			71.54	72.46	83.46	84.54	95.46	96.54
ANSI B 18.3.1 M (1986)	53.37	54.00			62.31	63.00			71.27	72.00				
Head Height k	min.	max.	min.	max.	min.	max.	min.	max.	min.	max.	min.	max.	min.	max.
DIN 912 (1983)	35.38	36.00	38.38	39.00	41.38	42.00	44.38	45.00	47.38	48.00	55.26	56.00	63.26	64.00
ISO 4762 (1997)	35.38	36.00			41.38	42.00			47.38	48.00	55.26	56.00	63.26	64.00
ANSI B 18.3.1 M (1986)	35.64	36.00			41.61	42.00			47.58	48.00				
Key Size nominal s	27		27		32		32		36		41		46	
	min.	max.	min.	max.	min.	max.	min.	max.	min.	max.	min.	max.	min.	max.
DIN 912 (1983)	27.065	27.275	27.065	27.275	32.080	32.330	32.080	32.330	36.080	36.330	41.080	41.330	46.080	46.330
ISO 4762 (1997)	27.065	27.275			32.080	32.330			36.080	36.330	41.080	41.330	46.080	46.330
ANSI B 18.3.1 M (1986)	27.065	27.319			32.080	32.461			36.080	36.461				
Key Engagement t	min.		min.		min.		min.		min.		min.		min.	
DIN 912 (1983)	19.0		22.0		24.0		24.0		28.0		34.0		38.0	
ISO 4762 (1997)	19.0				24.0				28.0		34.0		38.0	
ANSI B 18.3.1 M (1986)	18.0				21.0				24.0					

Thread Size d1	M72		M80		M90		M100	
Thread Pitch	6		6		6		6	
Thread Length b	220mm & Longer 156mm		240mm & Longer 172mm		260mm & Longer 192mm		280mm & Longer 212mm	
Head Dia. d2	min.	max.	min.	max.	min.	max.	min.	max.
DIN 912 (1983)	107.46	108.54	119.46	120.54	134.37	135.63	149.37	150.63
Head Height k	min.	max.	min.	max.	min.	max.	min.	max.
DIN 912 (1983)	71.26	72.00	79.26	80.00	89.13	90.00	99.13	100.00
Key Size nominal s	55		65		75		85	
	min.	max.	min.	max.	min.	max.	min.	max.
DIN 912 (1983)	55.100	55.400	65.100	65.400	75.100	75.400	85.120	85.470
Key Engagement t	min.		min.		min.		min.	
DIN 912 (1983)	43.0		48.0		54.0		60.0	

Property Class	12.9		8.8sd 16mm		8.8sd 16mm		10.9		A2 / A4-50		A2 / A4-70		A2 / A4-80	
Tensile Strength	176900 psi		116000 psi		120350 psi		150800 psi		72500 psi		101500 psi		116000 psi	
Yield Strength	159500 psi		92800 psi		95700 psi		136300 psi		30450 psi		65250 psi		87000 psi	
Rockwell Hardness (HRC)	min.	max.	min.	max.	min.	max.	min.	max.	min.	max.	min.	max.	min.	max.
	39	44	22	32	23	34	32	39	NA	NA	NA	NA	NA	NA

Property Class	Steel	Steel	Stainless Steel
	12.9	8.8 & 10.9	A2 & A4
Finish	Furnace Black		Plain
Thread Tolerance	5g6g	6g	

Diameters & Lengths With () are not recommended for new design.

M1.4, 2.6, 39 and 45 are no longer included in DIN 912.

M1.4, 2.6, 18, 22, 27, 33, 39, and 45 are no longer included in ISO 4762.

The basic difference between DIN 912-12.9 (1983) / ISO 4762-12.9 (1997) and ANSI B 18.3.1M (1986) is both DIN and ISO have a thread tolerance of 5g6g, while ANSI has a thread tolerance of 4g6g, which may not be readily available on a worldwide basis.

ANSI B 18.3.1 M is only available in Property Class 12.9.

FOR MORE DETAILED INFORMATION, PLEASE REFER TO COMPLETE DIN, ISO, OR ANSI STANDARD, WHICH ARE THE GOVERNING STANDARDS

DIN 912 (1983) / ISO 4762 (1997) / ANSI B 18.3.1M (1982) - LFG 10/01/10 REVISED

Length Tolerance	DIN 912		ISO 4762		ANSI B18.3.1M M1.6 Thru M10		ANSI B18.3.1M M12 Thru M20		ANSI B18.3.1M Over M20	
	min.	max.	min.	max.	min.	max.	min.	max.	min.	max.
Nominal Length										
2	1.80	2.20	1.80	2.20						
2.5	2.30	2.70	2.30	2.70	2.20	2.80				
3	2.80	3.20	2.80	3.20	2.70	3.30				
4	3.76	4.24	3.76	4.24	3.70	4.30				
5	4.76	5.24	4.76	5.24	4.70	5.30				
6	5.76	6.24	5.76	6.24	5.70	6.30				
8	7.71	8.29	7.71	8.29	7.70	8.30				
10	9.71	10.29	9.71	10.29	9.70	10.30				
12	11.65	12.35	11.65	12.35	11.70	12.30				
(14)	13.65	14.35								
16	15.65	16.35	15.65	16.35	15.70	16.30	15.70	16.30		
(18)	17.65	18.35								
20	19.58	20.42	19.58	20.42	19.60	20.40	19.60	20.40		
(22)	21.58	22.42								
25	24.58	25.42	24.58	25.42	24.60	25.40	24.60	25.40		
(28)	27.58	28.42								
30	29.58	30.42	29.58	30.42	29.60	30.40	29.60	30.40		
35	34.50	35.50	34.50	35.50	34.60	35.40	34.60	35.40		
40	39.50	40.50	39.50	40.50	39.60	40.40	39.60	40.40	39.30	40.70
45	44.50	45.50	44.50	45.50	44.60	45.40	44.60	45.40	44.30	45.70
50	49.50	50.50	49.50	50.50	49.60	50.40	49.60	50.40	49.30	50.70
55	54.40	55.60	54.40	55.60	54.30	55.70	54.00	56.00	53.50	56.50
60	59.40	60.60	59.40	60.60	59.30	60.70	59.00	61.00	58.50	61.50
65	64.40	65.60	64.40	65.60	64.30	65.70	64.00	66.00	63.50	66.50
70	69.40	70.60	69.40	70.60	69.30	70.70	69.00	71.00	68.50	71.50
(75)	74.40	75.60								
80	79.40	80.60	79.40	80.60	79.30	80.70	79.00	81.00	78.50	81.50
(85)	84.30	85.70								
90	89.30	90.70	89.30	90.70	89.30	90.70	89.00	91.00	88.50	91.50
(95)	94.30	95.70								
100	99.30	100.70	99.30	100.70	99.30	100.70	99.00	101.00	98.50	101.50
110	109.30	110.70	109.30	110.70	109.30	110.70	109.00	111.00	108.50	111.50
120	119.30	120.70	119.30	120.70	119.30	120.70	119.00	121.00	118.50	121.50
130	129.20	130.80	129.20	130.80	129.00	131.00	128.50	131.50	128.00	132.00
140	139.20	140.80	139.20	140.80	139.00	141.00	138.50	141.50	138.00	142.00
150	149.20	150.80	149.20	150.80	149.00	151.00	148.50	151.50	148.00	152.00
160	159.20	160.80	159.20	160.80	159.00	161.00	158.50	161.50	158.00	162.00
(170)	169.20	170.80								
180	179.20	180.80	179.20	180.80	179.00	181.00	178.50	181.50	178.00	182.00
(190)	189.08	190.93								
200	199.08	200.93	199.08	200.93	199.00	201.00	198.50	201.50	198.00	202.00
220	219.08	220.93	219.08	220.93	218.00	222.00	217.50	222.50	217.00	223.00
240	239.08	240.93	239.08	240.93	238.00	242.00	237.50	242.50	237.00	243.00
260	258.95	261.05	258.95	261.05	258.00	262.00	257.50	262.50	257.00	263.00
280	278.95	281.05	278.95	281.05						
300	298.95	301.05	298.95	301.05	298.00	302.00	297.50	302.50	297.00	303.00
320	318.85	321.15								
340	338.85	341.15								
360	358.85	361.15								
380	378.85	381.15								
400	398.85	401.15								
420	418.75	421.25								
440	438.75	441.25								
460	458.75	461.25								
480	478.75	481.25								
500	498.75	501.25								

FOR MORE DETAILED INFORMATION, PLEASE REFER TO COMPLETE DIN, ISO, OR ANSI STANDARD, WHICH ARE THE GOVERNING STANDARDS

DIN 912 (1983) / ISO 4762 (1997) / ANSI B 18.3.1M (1982) - LF6 10/01/10 REVISED



Get quote

Angic Global Solutions

1-888-872-0690 Rights Reserved

<https://www.AngicGlobal.com> Sales@AngicGlobal.com

SOCKET HEAD CAP SCREWS WITH FLANGE ATTACHED ▪ BN 1392 / BN 3873

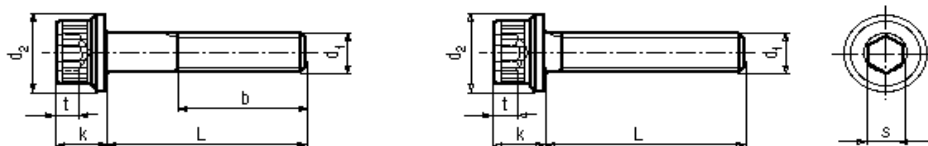

Thread Size d1	M4	M5	M6	M8	M10	M12	Material	Steel	
Thread Pitch	0.7	0.8	1	1.25	1.5	1.75	Property Class	12.9	
Thread Length b	14	16	18	22	26	30	Finish	Furnace Black	
Head Dia. Not to include Flange	7	8.5	10	13	16	18	Thread Tolerance	6g	
Head Dia. to include Flange d2	9.0	11.0	12.5	17.0	21.0	24.0	Tensile Strength	176900 psi	
Head Height to include Flange k	4	5	6	8	10	12	Yield Strength	159500 psi	
Key Size s	3	4	5	6	8	10	Rockwell Hardness (HRC)	min. 39	
Key Engagement t	2.2	2.5	3.0	4.0	5.0	6.0		max. 44	
Length L	Thread Length								
8									
10									
12									
16									
20									
25									
30									
35									
40									
50									
60									
70									
80									
90									
100									

1.4 - FLANGE SOCKET HEAD CAP SCREWS

SOCKET HEAD CAP SCREWS WITH SERRATED (LOCKING) FLANGE ATTACHED ▪ BN 1392 / BN 3873

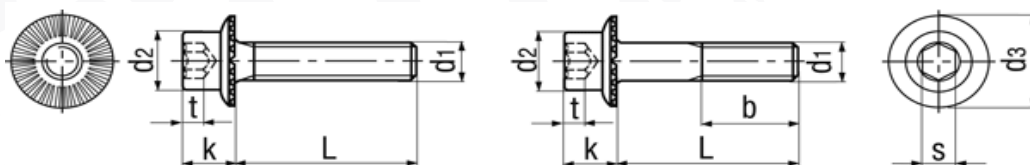

Thread Size d1	M5	M6	M8	M10	M12	Material	Steel	
Thread Pitch	0.8	1	1.25	1.5	1.75	Property Class	100	
Thread Length b	22	24	28	32	36	Finish	Furnace Black	
Head Dia. max. d2	9	11	14	17	19	Thread Tolerance	6g	
Flange Dia. max. d3	11.0	13.5	17.0	19.5	22.5	Tensile Strength	min. 145000 psi	
Head Height to include Flange k	5	6	8	10	12		max. 174000 psi	
Key Size s	4	5	6	8	10	Rockwell Hardness (HRC)	min. 32	
Key Engagement t	2.5	3.0	4.0	5.0	6.0		max. 38	
Length L	Thread Length							
10								
12								
16								
20								
25								
30								
35								
40								
45								
50								

FOR MORE DETAILED INFORMATION, PLEASE REFER TO BOSSARD BN 1392 AND 3873, WHICH ARE THE GOVERNING STANDARDS

©2005 BY BOSSARD - LFG 10-01-2016 REVISED

LOW HEAD SOCKET HEAD CAP SCREWS WITH PILOT RECESS - DIN 6912

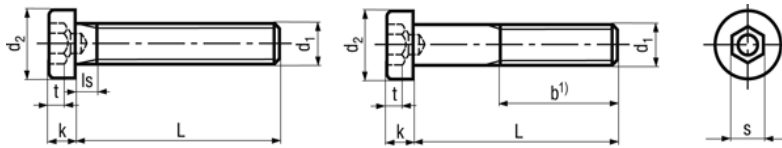

Thread Size d1		M4	M5	M6	M8	M10	M12	(M14)	M16	(M18)	M20	(M22)	M24	(M27)	M30	(M33)	M36
Thread Pitch		0.7	0.8	1	1.25	1.5	1.75	2	2	2.5	2.5	2.5	3	3	3.5	3.5	4
Shank Length min. ls		1.4	1.8	2.5	3.2	3.5	4.2	4.5	5.0	5.5	6.5	6.5	7.0	8.0	8.5	9.5	10.5
Thread Length b1 (min.)	For Lengths ≤125mm	14	16	18	22	26	30	34	38	42	46	50	54	60	66	72	78
	For Lengths >125mm≤200mm					32	36	40	44	48	52	56	60	66	72	78	84
	For Lengths >200 mm								57	61	65	69	73	79	85	91	97
Head Dia. d2	min.	6.78	8.28	9.78	12.73	15.73	17.73	20.67	23.67	26.67	29.67	32.61	35.61	39.61	44.61	49.61	53.54
	max. = nominal	7.00	8.50	10.00	13.00	16.00	18.00	21.00	24.00	27.00	30.00	33.00	36.00	40.00	45.00	50.00	54.00
Head Height k	min.	2.66	3.32	3.82	4.82	6.28	7.28	8.28	9.78	10.73	11.73	12.73	13.73	15.73	17.23	19.17	21.17
	max. = nominal	2.80	3.50	4.00	5.00	6.50	7.50	8.50	10.00	11.00	12.00	13.00	14.00	16.00	17.50	19.50	21.50
Key Size s	Nominal Size	3	4	5	6	8	10	12	14	14	17	17	19	19	22	24	27
	min.	3.020	4.020	5.020	6.020	8.025	10.025	12.032	14.032	14.032	17.050	17.050	19.065	19.065	22.065	24.065	27.065
	max.	3.100	4.120	5.140	6.140	8.175	10.175	12.212	14.212	14.212	17.230	17.230	19.275	19.275	22.275	24.275	27.275
Key Engagement t	min.	1.48	1.88	2.38	2.88	3.35	3.85	4.35	5.35	5.85	6.32	6.82	8.32	8.82	9.82	11.28	
	max.	1.72	2.12	2.62	3.12	3.65	4.15	4.65	5.65	6.15	6.68	7.18	7.18	8.68	9.18	10.18	11.72

1.5 - LOW HEAD SOCKET HEAD CAP SCREWS

LOW HEAD SOCKET HEAD CAP SCREWS - DIN 7984

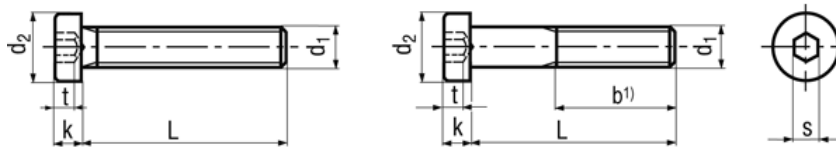

DIN 6912 / 7984		
Nominal Length L	Length Tolerance	
	min.	max.
5	4.760	5.240
6	5.760	6.240
8	7.710	8.290
10	9.710	10.290
12	11.650	12.350
(14)	13.650	14.350
16	15.650	16.350
(18)	17.650	18.350
20	19.580	20.420
(22)	21.580	22.420
25	24.580	25.420
(28)	27.580	28.420
30	29.580	30.420
35	34.500	35.500
40	39.500	40.500
45	44.500	45.500
50	49.500	50.500
55	54.400	55.600
60	59.400	60.600
65	64.400	65.600
70	69.400	70.600
(75)	74.400	75.600
80	79.400	80.600
(85)	84.300	85.700
90	89.300	90.700
(95)	94.300	95.700
100	99.300	100.700
110	109.300	110.700
120	119.300	120.700
130	129.200	130.800
140	139.200	140.800
150	149.200	150.800
160	159.200	160.800
(170)	169.200	170.800
180	179.200	180.800
(190)	189.075	190.925
200	199.075	200.925

Thread Size d1		M3	M4	M5	M6	M8	M10	M12	(M14)	M16	(M18)	M20	(M22)	M24	25	24.580	25.420
Thread Pitch		0.5	0.7	0.8	1	1.25	1.5	1.75	2	2	2.5	2.5	2.5	3	(28)	27.580	28.420
Thread Length b1 (min.)	For Lengths ≤125mm	12	14	16	18	22	26	30	34	38	42	46	50	54	30	29.580	30.420
	For Lengths >125mm≤200mm					28	32	36	40	44	48	52	56	60	35	34.500	35.500
	For Lengths >200 mm									57	61	65	69	73	40	39.500	40.500
Head Dia. d2	min.	5.32	6.78	8.28	9.78	12.73	15.73	17.73	20.67	23.67	26.67	29.67	32.61	35.61	60	59.400	60.600
	max. = nominal	5.50	7.00	8.50	10.00	13.00	16.00	18.00	21.00	24.00	27.00	30.00	33.00	36.00	65	64.400	65.600
Head Height k	min.	1.86	2.66	3.32	3.82	4.82	5.82	6.78	7.78	8.78	9.78	10.73	11.73	12.73	70	69.400	70.600
	max. = nominal	2.00	2.80	3.50	4.00	5.00	6.00	7.00	8.00	9.00	10.00	11.00	12.00	13.00	(75)	74.400	75.600
Key Size s	Nominal Size	2	2.5	3	4	5	7	8	10	12	12	14	14	17	80	79.400	80.600
	min.	2.020	2.520	3.020	4.020	5.020	7.025	8.025	10.025	12.032	12.032	14.032	14.032	17.050	(85)	84.300	85.700
	max.	2.100	2.600	3.100	4.120	5.140	7.175	8.175	10.175	12.212	12.212	14.212	14.212	17.230	90	89.300	90.700
Key Engagement t	min.	1.38	2.18	2.58	2.88	3.65	4.35	4.85	5.15	5.35	6.32	7.32	7.82	7.82	(95)	94.300	95.700
	max.	1.62	2.42	2.82	3.12	3.95	4.65	5.15	5.45	5.65	6.68	7.68	8.18	8.18	100	99.300	100.700

Diameters & Lengths With () are not recommended for new design.

Property Class	Steel	Stainless Steel
	8.8	A2 & A4
Finish	Furnace Black	Plain
Thread Tolerance	6g	6g

DIN 6912
DIN 7984
Neither of these designs are intended for high strength applications.

DIN 7984 Standard only covers through 100mm long.

FOR MORE DETAILED INFORMATION, PLEASE REFER TO COMPLETE DIN STANDARD, WHICH IS THE GOVERNING STANDARD

DIN 6912 (1985) / DIN 7984 (1970)- LFG 10/01/2016 REVISED



Get quote »

Angic Global Solutions

1-888-872-0690 Rights Reserved

<https://www.AngicGlobal.com> Sales@AngicGlobal.com

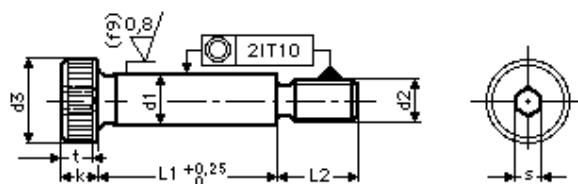

According To ISO 7379, Head Can Be Plain Or Knurled As Shown Here

Shoulder Diameter d1	6 (1)	8	10	12 (1)	16
Shoulder min.	5.960	7.951	9.951	11.941	15.941
Shoulder max.	5.990	7.987	9.987	11.984	15.984
Shoulder Diameter Tolerance	-.010 mm to -.040 mm		-.013 mm to -.049 mm		-.016 mm to -.059 mm
Shoulder Length Tolerance	+0.25 mm	+0.25 mm	+0.25 mm	+0.25 mm	+0.25 mm
Thread Size & Pitch d2	M5x0.8	M6x1	M8x1.25	M10x1.5	M12x1.75
Thread Class	5g6g	5g6g	5g6g	5g6g	5g6g
Thread Length L2	9.5	11.0	13.0	16.0	18.0
Head Diameter d3	10	13	16	18	24
Head Height max. k	4.50	5.50	7.00	9.00	11.00
Head Height min. k	4.32	5.32	6.78	7.78	9.73
Drive Size s	3	4	5	6	8
Drive Depth min. t	2.4	3.3	4.2	4.9	6.6
Tensile Strength min. psi	159500	159500	159500	159500	159500
Shear Strength psi	95700	95700	95700	95700	95700
Rockwell Hardness	C39-C44	C39-C44	C39-C44	C39-C44	C39-C44

Shoulder Diameter d1	20	24 (1)	Shoulder Bolts	Material	12.9
Shoulder min.	19.928	23.928		Finish	Furnace Black
Shoulder max.	19.980	23.980		Shoulder	Ground
Shoulder Diameter Tolerance	-.020 mm to -.072 mm		Due to the undercut between the shoulder and the thread, the tightening torque has to be lowered from the normal torque for 12.9 material. The 12.9 material is to increase wear resistance on the shoulder.		
Shoulder Length Tolerance	+0.25 mm	+0.25 mm			
Thread Size & Pitch d2	M16x2	M20x2.5			
Thread Class	5g6g	5g6g			
Thread Length L2	22.0	27.0			
Head Diameter d3	30	36	The basic difference between ~ISO 7379 (1983) and ANSI B 18.3.3M (1986) is ANSI has a thread tolerance of 4g6g.		
Head Height max. k	14.00	16.00			
Head Height min. k	13.73	15.73			
Drive Size s	10	12	(1) These sizes are not included in the ISO 7379 standard, but are the accepted sizes in today's market. ISO recognizes 6.5, 13, and 25mm, but these sizes are not readily available outside of production quantities.		
Drive Depth min. t	8.8	10.0			
Tensile Strength min. psi	159500	159500			
Shear Strength psi	95700	95700			
Rockwell Hardness	C39-C44	C39-C44			

FOR MORE DETAILED INFORMATION, PLEASE REFER TO COMPLETE ISO STANDARD , WHICH IS THE GOVERNING STANDARD

ISO 7379 (1983) - LFG 10/01/2016 REVISED

FLAT HEAD SOCKET CAP SCREWS • DIN 7991 / ISO 10642 / ANSI B18.3.5M

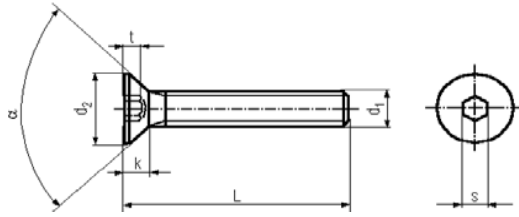

*****Notice*****
Lindstrom Metric, LLC will supply all Flat Head Socket Cap Screws With Full Thread, not according to below formulas.

Thread Size d1		(M2)	(M2.5)	M3	M4	M5	M6	M8	M10	M12	(M14)	M16	(M18)	M20	(M22)	M24
Thread Pitch		0.4	0.45	0.5	0.7	0.8	1	1.25	1.5	1.75	2	2	2.5	2.5	2.5	3
Head Angle a		90°	90°	90°	90°	90°	90°	90°	90°	90°	90°	90°	90°	90°	60°	60°
DIN 7991 Thread Length Formula	For Lengths ≤125mm	10	11	12	14	16	18	22	26	30	34	38	42	46	50	54
	For Lengths >125mm≤200mm						24	28	32	36	40	44	48	52	56	60
	For Lengths >200 mm								45	49	53	57	61	65	69	73
ISO 10642 & ANSI B18.3.5M use a shank length / grip length formula to determine thread length. - Refer to full ISO or ANSI standard for more details.																
DIN 7991 Head Dia. d2	min.	3.70	4.70	5.70	7.64	9.64	11.57	15.57	19.48	23.48	26.48	29.48	32.38	35.38	35.38	38.38
	max. = nominal	4.00	5.00	6.00	8.00	10.00	12.00	16.00	20.00	24.00	27.00	30.00	33.00	36.00	36.00	39.00
ISO 10642 Head Dia. d2	min.			5.54	7.53	9.43	11.34	15.24	19.22	23.12	26.52	29.01		36.05		
	max. = theoretical			6.72	8.96	11.20	13.44	17.92	22.40	26.88	30.80	33.60		40.32		
ANSI B18.3.5M Head Dia. d2	min.			5.35	7.80	9.75	11.70	15.65	19.50	23.40	26.18	23.76		34.60		
	max. = theoretical			6.72	8.96	11.20	13.44	17.92	22.40	26.88	30.24	33.60		40.32		

ISO 10642 & ANSI B18.3.5M use a theoretical value for the max head diameter, which represents the exact diameter of a hole countersunk to exactly 90° in which a screw having the maximum head size will fit flush. - Refer to full ISO or ANSI standard for more details.

DIN 7991 Head Height k	max.	1.2	1.5	1.7	2.3	2.8	3.3	4.4	5.5	6.5	7.0	7.5	8.0	8.5	13.1	14.0
ISO 10642 Head Height k	max. = reference			1.86	2.48	3.10	3.72	4.96	6.20	7.44	8.40	8.80		10.16		
ANSI B18.3.5M Head Height k	max. = reference			1.86	2.48	3.10	3.72	4.96	6.20	7.44	8.12	8.80		10.16		

ISO 10642 & ANSI B18.3.5M show Head Height k as a reference point only. - Refer to full ISO or ANSI standard for more details.
For DIN 7991 / ISO 10642 / ANSI B18.3.5M, the overall length of the screw includes the head.

DIN 7991 Key Size s	Nominal Size	1.3	1.5	2	2.5	3	4	5	6	8	10	10	12	12	14	14
	min.	1.275	1.545	2.020	2.520	3.020	4.020	5.020	6.020	8.025	10.025	10.025	12.032	12.032	14.032	14.032
	max.	1.300	1.520	2.100	2.600	3.100	4.120	5.140	6.140	8.175	10.175	10.175	12.212	12.212	14.212	14.212
ISO 10642 Key Size s	Nominal Size			2	2.5	3	4	5	6	8	10	10		12		
	min.			2.020	2.520	3.020	4.020	5.020	6.020	8.025	10.025	10.025		12.032		
	max.			2.060	2.580	3.080	4.095	5.140	6.140	8.175	10.175	10.175		12.212		
ANSI B18.3.5M Key Size s	Nominal Size			2	2.5	3	4	5	6	8	10	10		12		
	min.			2.020	2.520	3.020	4.020	5.020	6.020	8.025	10.025	10.025		12.032		
	max.			2.045	2.560	3.071	4.084	5.084	6.095	8.115	10.115	10.115		12.142		
DIN 7991 Key Engagement t	min.	0.750	0.800	0.950	1.550	2.050	2.250	3.200	4.100	4.300	4.500	5.000	5.200	5.600	8.440	9.870
ISO 10642 Key Engagement t	min.			1.100	1.500	1.900	2.200	3.000	3.600	4.300	4.500	4.800		5.600		
ANSI B18.3.5M Key Engagement t	min.			1.100	1.500	1.900	2.200	3.000	3.600	4.300	4.700	4.800		5.600		

Length Tolerance	DIN 7991 / ISO 10642		ANSI B18.3.5M		Length Tolerance	DIN 7991 / ISO 10642		ANSI B18.3.5M									
	min.	max.	min.	max.		Nominal Length	min.	max.	min.	max.							
Nominal Length																	
(4)	3.76	4.24	3.70	4.30	30	29.58	30.42	29.50	30.50								
(5)	4.76	5.24	4.70	5.30	35	34.50	35.50	34.50	35.50								
(6)	5.76	6.24	5.70	6.30	40	39.50	40.50	39.50	40.50								
8	7.71	8.29	7.70	8.30	45	44.50	45.50	44.50	45.50								
10	9.71	10.29	9.70	10.30	50	49.50	50.50	49.50	50.50								
12	11.65	12.35	11.70	12.30	(55)	54.40	55.60	54.50	55.50								
(14)	13.65	14.35	13.70	14.30	60	59.40	60.60	59.50	60.50								
16	15.65	16.35	15.70	16.30	(65)	64.40	65.60	64.20	65.80								
(18)	17.65	18.35	17.50	18.50	70	69.40	70.60	69.20	70.80								
20	19.58	20.42	19.50	20.50	(75)	74.40	75.60	74.20	75.80								
(22)	21.58	22.42	21.50	22.50	80	79.40	80.60	79.20	80.80								
25	24.58	25.42	24.50	25.50	90	89.30	90.70	89.20	90.80								
(28)	27.58	28.42	27.50	28.50	100	99.30	100.70	99.20	100.80								

*****Notice*****
Diameters and or Lengths shown with () are not shown in some standards and are not recommended for use in new design.

*****Notice*****
DIN 7991, ISO 10642, and ANSI B18.3.5M are not intended for high strength applications. The only purpose of having them produced in property class 10.9 or 12.9 is to increase the wear resistance of the socket drive.

	DIN 7991 / ISO 10642		ANSI B18.3.5M
Material	Steel	Stainless Steel	Steel
Property Class	10.9	A2 & A4	12.9
Tensile Strength	145000 psi	101500 psi	150800 psi
Finish	Furnace Black	Plain	Furnace Black
Thread Tolerance	6g	6g	4g6g

FOR MORE DETAILED INFORMATION, PLEASE REFER TO COMPLETE DIN, ISO OR ANSI STANDARD, WHICH ARE THE GOVERNING STANDARDS

DIN 7991 (1986) / ISO 10642 (1997) / ANSI B18.3.5M (1986 REV. 1993)- LFG 10/01/2016 REVISED

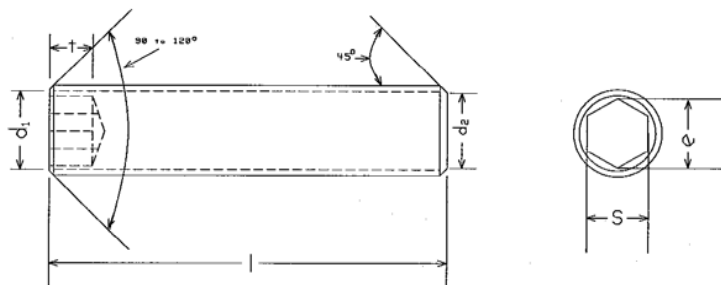

Thread Size d1		(M1.4)	M1.6	(M1.8)	M2	M2.5	M3	M4	M5	M6	M8	M10	M12	(M14)	M16	(M18)	M20	(M22)	M24
Thread Pitch		0.3	0.35	0.35	0.4	0.45	0.5	0.7	0.8	1	1.25	1.5	1.75	2	2	2.5	2.5	2.5	3
d2	min.	0.45	0.55	0.65	0.75	1.25	1.75	2.25	3.20	3.70	5.20	6.64	8.14	9.64	11.57	12.57	14.57	16.57	17.57
	max.	0.70	0.80	0.90	1.00	1.50	2.00	2.50	3.50	4.00	5.50	7.00	8.50	10.00	12.00	13.00	15.00	17.00	18.00
S	Nominal Size	0.7	0.7	0.7	0.9	1.3	1.5	2	2.5	3	4	5	6	6	8	10	10	12	12
	min.	0.711	0.711	0.711	0.889	1.270	1.520	2.020	2.520	3.020	4.020	5.020	6.020	6.020	8.025	10.025	10.025	12.032	12.032
	max.	0.724	0.724	0.724	0.902	1.295	1.545	2.045	2.560	3.080	4.095	5.095	6.095	6.095	8.115	10.115	10.115	12.142	12.142
t min.	above	0.6	0.7	0.8	0.8	1.2	1.2	1.5	2.0	2.0	3.0	4.0	4.8	5.6	6.4	7.2	8.0	9.0	10.0
	below	1.4	1.5	1.6	1.7	2.0	2.0	2.5	3.0	3.5	5.0	6.0	8.0	9.0	10.0	11.0	12.0	13.5	15.0

Nominal Length	Length		Minimum Depth Of Key Engagement - See t min. Above For Clarification To Actual Nominal Lengths																		
	min.	max.																			
2	1.80	2.20																			
2.5	2.30	2.70																			
3	2.80	3.20																			
(3.5)	3.26	3.74																			
4	3.76	4.24																			
5	4.76	5.24																			
6	5.76	6.24																			
8	7.71	8.29																			
10	9.71	10.29																			
12	11.65	12.35																			
(14)	13.65	14.35																			
16	15.65	16.35																			
(18)	17.65	18.35																			
20	19.58	20.42																			
(22)	21.58	22.42																			
25	24.58	25.42																			
(28)	27.58	28.42																			
30	29.58	30.42																			
35	34.50	35.50																			
40	39.50	40.50																			
45	44.50	45.50																			
50	49.50	50.50																			
55	54.40	55.60																			
60	59.40	60.60																			
70	69.40	70.60																			
80	79.40	80.60																			

Diameters With () are not in the ISO 4026 Standard and not recommended for new design.
 Lengths With () are not in the ISO 4026 Standard and are not recommended for new design.

Property Class	Steel	Stainless Steel
		45H
Finish	Furnace Black	Plain
Thread Tolerance	5g6g	6g

FOR MORE DETAILED INFORMATION, PLEASE REFER TO COMPLETE DIN OR ISO STANDARD, WHICH ARE THE GOVERNING STANDARDS

DIN 913 (1980) / ISO 4026 (1993) - LFG 10/01/10 REVISED

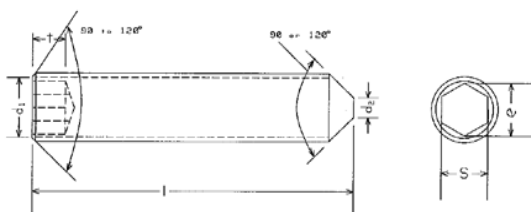

Thread Size d1		(M1.4)	M1.6	(M1.8)	M2	M2.5	M3	M4	M5	M6	M8	M10	M12	(M14)	M16	(M18)	M20	(M22)	M24
Thread Pitch		0.3	0.35	0.35	0.4	0.45	0.5	0.7	0.8	1	1.25	1.5	1.75	2	2	2.5	2.5	2.5	3
d2	min.									0.90	1.40	1.90	2.40	3.25	3.25	4.25	4.25	5.25	5.25
	max.									1.50	2.00	2.50	3.00	4.00	4.00	5.00	5.00	6.00	6.00
S	Nominal Size	0.7	0.7	0.7	0.9	1.3	1.5	2	2.5	3	4	5	6	6	8	10	10	12	12
	min.	0.711	0.711	0.711	0.889	1.270	1.520	2.020	2.520	3.020	4.020	5.020	6.020	6.020	8.025	10.025	10.025	12.032	12.032
	max.	0.724	0.724	0.724	0.902	1.295	1.545	2.045	2.560	3.080	4.095	5.095	6.095	6.095	8.115	10.115	10.115	12.142	12.142
t min.	above	0.6	0.7	0.8	0.8	1.2	1.2	1.5	2.0	2.0	3.0	4.0	4.5	5.6	6.4	7.2	8.0	9.0	10.0
	below	1.4	1.5	1.6	1.7	2.0	2.0	2.5	3.0	3.5	5.0	6.0	8.0	9.0	10.0	11.0	12.0	13.5	15.0

Nominal Length	Length		Minimum Depth Of Key Engagement - See t min. Above For Clarification To Actual Nominal Lengths																	
	min.	max.																		
2	1.80	2.20																		
2.5	2.30	2.70																		
3	2.80	3.20																		
(3.5)	3.26	3.74																		
4	3.76	4.24																		
5	4.76	5.24																		
6	5.76	6.24																		
8	7.71	8.29																		
10	9.71	10.29																		
12	11.65	12.35																		
(14)	13.65	14.35																		
16	15.65	16.35																		
(18)	17.65	18.35																		
20	19.58	20.42																		
(22)	21.58	22.42																		
25	24.58	25.42																		
(28)	27.58	28.42																		
30	29.58	30.42																		
35	34.50	35.50																		
40	39.50	40.50																		
45	44.50	45.50																		
50	49.50	50.50																		
55	54.40	55.60																		
60	59.40	60.60																		
70	69.40	70.60																		
80	79.40	80.60																		

Diameters With () are not in the ISO 4027 Standard and not recommended for new design.
 Lengths With () are not in the ISO 4027 Standard and are not recommended for new design.

Property Class	Steel	Stainless Steel
	45H	A1, A2, A4
Finish	Furnace Black	Plain
Thread Tolerance	5g6g	6g

Angle Of Cone Point	above	120°
	below	90°

FOR MORE DETAILED INFORMATION, PLEASE REFER TO COMPLETE DIN OR ISO STANDARD, WHICH ARE THE GOVERNING STANDARDS

DIN 914 (1980) / ISO 4027 (1993) - LFG 10/01/10 REVISED

SOCKET SET SCREWS DOG POINT - DIN 915 / ISO 4028

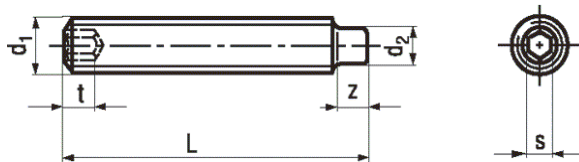

1.11 - SOCKET SET SCREWS - DOG POINT

Thread Size d1		(M1.4)	M1.6	(M1.8)	M2	M2.5	M3	M4	M5	M6	M8	M10	M12	(M14)	M16	(M18)	M20	(M22)	M24	
Thread Pitch		0.3	0.35	0.35	0.4	0.45	0.5	0.7	0.8	1	1.25	1.5	1.75	2	2	2.5	2.5	2.5	3	
d2	min.	0.45	0.55	0.65	0.75	1.25	1.75	2.25	3.20	3.70	5.20	6.64	8.14	9.64	11.57	12.57	14.57	16.57	17.57	
	max.	0.70	0.80	0.90	1.00	1.50	2.00	2.50	3.50	4.00	5.50	7.00	8.50	10.00	12.00	13.00	15.00	17.00	18.00	
s	Nominal Size	0.7	0.7	0.7	0.9	1.3	1.5	2	2.5	3	4	5	6	6	8	10	10	12	12	
	min.	0.711	0.711	0.711	0.889	1.270	1.520	2.020	2.520	3.020	4.020	5.020	6.020	6.020	8.025	10.025	10.025	12.032	12.032	
	max.	0.724	0.724	0.724	0.902	1.295	1.545	2.045	2.560	3.060	4.095	5.095	6.095	6.095	8.115	10.115	10.115	12.142	12.142	
t min.	above	0.6	0.7	0.8	0.8	1.2	1.2	1.5	2.0	2.0	3.0	4.0	4.8	5.6	6.4	7.2	8.0	9.0	10.0	
	below	1.4	1.5	1.6	1.7	2.0	2.0	2.5	3.0	3.5	5.0	6.0	8.0	9.0	10.0	11.0	12.0	13.5	15.0	
z	Dog pt (1)	min.	0.40	0.40	0.50	0.50	0.63	0.75	1.00	1.25	1.50	2.00	2.50	3.00	3.50	4.00	4.50	5.00	5.50	6.00
		max.	0.65	0.65	0.65	0.75	0.88	1.00	1.25	1.50	1.75	2.25	2.75	3.25	3.80	4.30	4.80	5.30	5.80	6.30
	Dog pt (2)	min.	0.80	0.80	1.00	1.00	1.25	1.50	2.00	2.50	3.00	4.00	5.00	6.00	7.00	8.00	9.00	10.00	11.00	12.00
		max.	1.05	1.05	1.25	1.25	1.50	1.75	2.25	2.75	3.25	4.30	5.30	6.30	7.36	8.36	9.86	10.36	11.43	12.43

Nominal Length	Length		Minimum Depth Of Key Engagement - See t min. Above For Clarification To Actual Nominal Lengths																	
	min.	max.																		
2	1.80	2.20																		
2.5	2.30	2.70																		
3	2.80	3.20																		
(3.5)	3.26	3.74																		
4	3.76	4.24																		
5	4.76	5.24																		
6	5.76	6.24																		
8	7.71	8.29																		
10	9.71	10.29																		
12	11.65	12.35																		
(14)	13.65	14.35																		
16	15.65	16.35																		
(18)	17.65	18.35																		
20	19.58	20.42																		
(22)	21.58	22.42																		
25	24.58	25.42																		
(28)	27.58	28.42																		
30	29.58	30.42																		
35	34.50	35.50																		
40	39.50	40.50																		
45	44.50	45.50																		
50	49.50	50.50																		
55	54.40	55.60																		
60	59.40	60.60																		
70	69.40	70.60																		
80	79.40	80.60																		

Diameters With () are not in the ISO 4028 Standard and not recommended for new design.

Lengths With () are not in the ISO 4028 Standard and are not recommended for new design.

Property Class	Steel	Stainless Steel
	45H	A1, A2, A4
Finish	Furnace Black	Plain
Thread Tolerance	5g6g	6g

Length Of Dog Point	above	1
	below	2

FOR MORE DETAILED INFORMATION, PLEASE REFER TO COMPLETE DIN OR ISO STANDARD, WHICH ARE THE GOVERNING STANDARDS

DIN 915 (1980) / ISO 4028 (1993) - LFG 10/01/10 REVISED

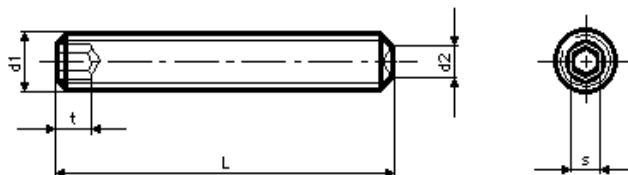

Thread Size d1		(M1.4)	M1.6	(M1.8)	M2	M2.5	M3	M4	M5	M6	M8	M10	M12	(M14)	M16	(M18)	M20	(M22)	M24
Thread Pitch		0.3	0.35	0.35	0.4	0.45	0.5	0.7	0.8	1	1.25	1.5	1.75	2	2	2.5	2.5	2.5	3
d2	min.	0.45	0.55	0.65	0.75	0.95	1.15	1.75	2.25	2.75	4.70	5.70	7.64	8.64	9.64	11.57	13.57	15.57	15.57
	max.	0.70	0.80	0.90	1.00	1.20	1.40	2.00	2.50	3.00	5.00	6.00	8.00	9.00	10.00	12.00	14.00	16.00	16.00
s	Nominal Size	0.7	0.7	0.7	0.9	1.3	1.5	2	2.5	3	4	5	6	6	8	10	10	12	12
	min.	0.711	0.711	0.711	0.889	1.270	1.520	2.020	2.520	3.020	4.020	5.020	6.020	6.020	8.025	10.025	10.025	12.032	12.032
t min.	above	0.6	0.7	0.8	0.8	1.2	1.2	1.5	2.0	2.0	3.0	4.0	4.8	5.6	6.4	7.2	8.0	9.0	10.0
	below	1.4	1.5	1.6	1.7	2.0	2.0	2.5	3.0	3.5	5.0	6.0	8.0	9.0	10.0	11.0	12.0	13.5	15.0

Nominal Length	Length		Minimum Depth Of Key Engagement - See t min. Above For Clarification To Actual Nominal Lengths																	
	min.	max.																		
2	1.80	2.20																		
2.5	2.30	2.70																		
3	2.80	3.20																		
(3.5)	3.26	3.74																		
4	3.76	4.24																		
5	4.76	5.24																		
6	5.76	6.24																		
8	7.71	8.29																		
10	9.71	10.29																		
12	11.65	12.35																		
(14)	13.65	14.35																		
16	15.65	16.35																		
(18)	17.65	18.35																		
20	19.58	20.42																		
(22)	21.58	22.42																		
25	24.58	25.42																		
(28)	27.58	28.42																		
30	29.58	30.42																		
35	34.50	35.50																		
40	39.50	40.50																		
45	44.50	45.50																		
50	49.50	50.50																		
55	54.40	55.60																		
60	59.40	60.60																		
70	69.40	70.60																		
80	79.40	80.60																		

Diameters With () are not in the ISO 4029 Standard and not recommended for new design.
 Lengths With () are not in the ISO 4029 Standard and are not recommended for new design.

Property Class	Steel	Stainless Steel
	45H	A1, A2, A4
Finish	Furnace Black	Plain
Thread Tolerance	5g6g	6g

FOR MORE DETAILED INFORMATION, PLEASE REFER TO COMPLETE DIN OR ISO STANDARD, WHICH ARE THE GOVERNING STANDARDS

DIN 916 (1980) / ISO 4029 (1993) - LFG 10/01/10 REVISED

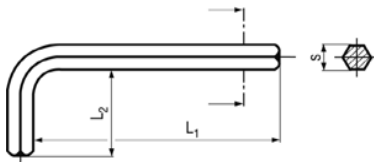

ISO 2036 Key Size s	s Tolerance		Standard Arm L1	Long Arm L1	Extra Long Arm L1	L1 Limit Deviations	Arm L2	L2 Limit Deviations	Rockwell Hardness	Fits Dia. Socket Cap Screws	Fits Dia. Socket Set Screws	Fits Dia. Button & Flat Socket Screws	Fits Dia. Shoulder Screws	Fits Dia. Low Head Socket Screws			
	min.	max.															
(0.7)	0.70	0.71	33			0-2mm	7	0-2mm	52 HRC		1.4/1.6						
(0.9)	0.88	0.89	33				11						2				
(1.3)	1.24	1.27	41	63.5	81		13					1.4	2.5	2			
(1.5)	1.48	1.50	46.5	63.5	91.5		15.5					1.6/2	3	2.5			
(2)	1.96	2.00	52	77	102		18					2.5/2.6	4	3			3
2.5	2.46	2.50	58.5	87.5	114.5	20.5					3	5	4			4	
3	2.96	3.00	66	93	129	23					4	6	5	6		5	
(3.5)	3.45	3.50	69.5	98.5	140	25.5											
4	3.95	4.00	74	104	144	29					5	8	6	8		6	
(4.5)	4.45	4.50	80	114.5	156	30.5											
5	4.95	5.00	85	120	165	33			6	10	8	10		8			
6	5.95	6.00	96	141	186	38			8	12/14	10	12					
(7)	6.94	7.00	102	147	197	41								10			
8	7.94	8.00	108	158	208	44			10	16	12	16		12			
(9)	8.94	9.00	114	169	219	47											
10	9.94	10.00	122	180	234	50			12	18/20	14/16	20					
(11)	10.89	11.00	129	191	247	53											
12	11.89	12.00	137	202	262	57			14	22/24	20	12		16			
(13)	12.89	13.00	145	213	277	63											
14	13.89	14.00	154	229	294	70			16/18		24			20			
(15)	14.89	15.00	161	240	307	73											
(16)	15.89	16.00	168	240	307	76											
17	16.89	17.00	177	262	337	80			20/22					24			
(18)	17.89	18.00	188	262	358	84											
19	18.87	19.00	199			89			24/27								
(21)	20.87	21.00	211			96											
22	21.87	22.00	222			102			30								
(23)	22.87	23.00	233			108											
24	23.87	24.00	248			114			33								
27	26.87	27.00	277			127			36/39								
(29)	28.87	29.00	311			141											
(30)	29.87	30.00	315			142											
32	31.84	32.00	347			157			42/45								
36	35.84	36.00	391			176			48								

The dimensions for ISO 2936 and ANSI B 18 3.2M are basically the same and should have little if any impact during use of same.

FOR MORE DETAILED INFORMATION, PLEASE REFER TO COMPLETE ISO STANDARD, WHICH IS THE GOVERNING STANDARD

ISO 2936 (2001) / ANSI B 18.3.2 M (1979) - LFG 10/01/10 REVISED

HEX HEAD CAP SCREWS - COARSE PITCH ▪ DIN 931/933 / ISO 4014/4017 / JIS B1180 / ANSI B 18.2.3.1M

For Screws Not Fully Threaded, The Thread Length Shown Is Minimum

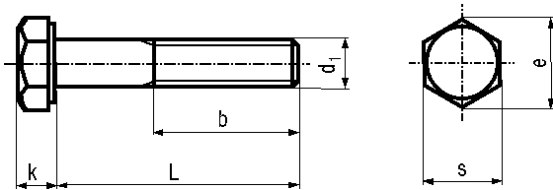

DIN 931 / ISO 4014 Partial Thread
DIN 933 / ISO 4017 Full Thread

Width Across Flats s	M2		M3		M4		M5		M6		(M7)		M8	
Standard	min.	max.	min.	max.	min.	max.	min.	max.	min.	max.	min.	max.	min.	max.
DIN 931/933 (1987)	3.82	4.00	5.32	5.50	6.78	7.00	7.78	8.00	9.78	10.00	10.73	11.00	12.73	13.00
ISO 4014/4017 (1988)	3.82	4.00	5.32	5.50	6.78	7.00	7.78	8.00	9.78	10.00			12.73	13.00
JIS B 1180 (1977)													11.75	12.00
ANSI B 18.2.3.1M (1979)							7.78	8.00	9.78	10.00			12.73	13.00

Head Height k	M2		M3		M4		M5		M6		(M7)		M8	
DIN 931/933 (1987)	1.280	1.520	1.880	2.120	2.680	2.920	3.350	3.650	3.850	4.150	4.650	4.950	5.150	5.450
ISO 4014/4017 (1988)	1.275	1.525	1.875	2.125	2.675	2.925	3.350	3.650	3.850	4.150			5.150	5.450
JIS B 1180 (1977)													5.350	5.650
ANSI B 18.2.3.1M (1979)							3.350	3.650	3.850	4.150			5.100	5.500

Comparable Thread Lengths For DIN - ISO - JIS - ANSI														
DIN 931	M2		M3		M4		M5		M6		(M7)		M8	
Lengths ≤125mm	10		12		14		16		18		20		22	
Lengths >125mm≤200mm							22		24		26		28	
Lengths >200 mm													41	
ISO 4014	M2		M3		M4		M5		M6		(M7)		M8	
Lengths ≤125mm	10		12		14		16		18				22	
Lengths >125mm≤200mm														
Lengths >200 mm														
JIS 1180	M2		M3		M4		M5		M6		(M7)		M8	
Lengths ≤125mm													22	
Lengths >125mm≤200mm														
Lengths >200 mm														
ANSI B18.2.3.1M	M2		M3		M4		M5		M6		(M7)		M8	
Lengths ≤125mm							16		18				22	
Lengths >125mm≤200mm							22		24				28	
Lengths >200 mm							35		37				41	

Width Across Flats s	M10		M12		(M14)		M16		(M18)		M20		(M22)	
Standard	min.	max.	min.	max.	min.	max.	min.	max.	min.	max.	min.	max.	min.	max.
DIN 931/933 (1987)	16.73	17.00	18.67	19.00	21.67	22.00	23.67	24.00	26.67	27.00	29.67	30.00	31.61	32.00
ISO 4014/4017 (1988)	15.73	16.00	17.73	18.00	20.67	21.00	23.67	24.00	26.67	27.00	29.67	30.00	33.38	34.00
JIS B 1180 (1977)	13.75	14.00	16.65	17.00										
ANSI B 18.2.3.1M (1979)	15.73	16.00	17.73	18.00	20.67	21.00	23.67	24.00			29.16	30.00		

Head Height k	M10		M12		(M14)		M16		(M18)		M20		(M22)	
DIN 931/933 (1987)	6.220	6.580	7.320	7.680	8.620	8.980	9.820	10.180	11.280	11.720	12.280	12.720	13.780	14.220
ISO 4014/4017 (1988)	6.220	6.580	7.320	7.680	8.620	8.980	9.820	10.180	11.285	11.715	12.285	12.715	13.785	14.215
JIS B 1180 (1977)	6.800	7.200	7.800	8.200										
ANSI B 18.2.3.1M (1979)	6.170	6.630	7.240	7.760	8.510	9.090	9.680	10.320			12.120	12.880		

Comparable Thread Lengths For DIN - ISO - JIS - ANSI														
DIN 931	M10		M12		(M14)		M16		(M18)		M20		(M22)	
Lengths ≤125mm	26		30		34		38		42		46		50	
Lengths >125mm≤200mm	32		36		40		44		48		52		56	
Lengths >200 mm	45		49		53		57		61		65		69	
ISO 4014	M10		M12		(M14)		M16		(M18)		M20		(M22)	
Lengths ≤125mm	26		30		34		38		42		46		50	
Lengths >125mm≤200mm					40		44		48		52		56	
Lengths >200 mm													69	
JIS 1180	M10		M12		(M14)		M16		(M18)		M20		(M22)	
Lengths ≤125mm	26		30											
Lengths >125mm≤200mm														
Lengths >200 mm														
ANSI B18.2.3.1M	M10		M12		(M14)		M16		(M18)		M20		(M22)	
Lengths ≤125mm	26		30		34		38				46			
Lengths >125mm≤200mm	32		36		40		44				52			
Lengths >200 mm	45		49		53		57				65			

FOR MORE DETAILED INFORMATION, PLEASE REFER TO COMPLETE DIN, ISO, JIS OR ANSI STANDARD, WHICH ARE THE GOVERNING STANDARDS

DIN 931/933 (1987) / ISO 4014/4017 (1988) / JIS B1180 (1977) / ANSI B 18.2.3.1M (1979) - LFG 10/01/2016 REVISED

HEX HEAD CAP SCREWS - COARSE PITCH ▪ DIN 931/933 / ISO 4014/4017 / JIS B1180 / ANSI B 18.2.3.1M

2.2 - HEX HEAD CAP SCREWS - COARSE PITCH

For Screws Not Fully Threaded, The Thread Length Shown Is Minimum

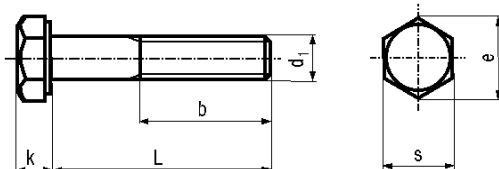

DIN 931 / ISO 4014 Partial Thread
DIN 933 / ISO 4017 Full Thread

Width Across Flats s	M24		(M27)		M30		(M33)		M36		(M39)		M42	
Standard	min.	max.	min.	max.	min.	max.	min.	max.	min.	max.	min.	max.	min.	max.
DIN 931/933 (1987)	35.38	36.00	40.00	41.00	45.00	46.00	49.00	50.00	53.80	55.00	58.80	60.00	63.10	65.00
ISO 4014/4017 (1988)	35.38	36.00	40.00	41.00	45.00	46.00	49.00	50.00	53.80	55.00	58.80	60.00	63.10	65.00
ANSI B 18.2.3.1M (1979)	35.00	36.00			45.00	46.00			53.80	55.00				

Head Height k	M24		(M27)		M30		(M33)		M36		(M39)		M42	
DIN 931/933 (1987)	14.780	15.220	16.650	17.350	18.280	19.120	20.580	21.420	22.080	22.920	24.580	25.420	25.580	26.420
ISO 4014/4017 (1988)	14.785	15.215	16.650	17.350	18.280	19.120	20.580	21.420	22.080	22.920	24.580	25.420	25.580	26.420
ANSI B 18.2.3.1M (1979)	14.560	15.440			17.920	19.480			21.620	23.380				

Comparable Thread Lengths For DIN - ISO - ANSI														
DIN 931	M24		(M27)		M30		(M33)		M36		(M39)		M42	
Lengths ≤125mm	54		60		66		72		78		84		90	
Lengths >125mm≤200mm	60		66		72		78		84		90		96	
Lengths >200 mm	73		79		85		91		97		103		109	
ISO 4014	M24		(M27)		M30		(M33)		M36		(M39)		M42	
Lengths ≤125mm	54		60		66		78		84		90		96	
Lengths >125mm≤200mm	60		66		72		78		84		90		96	
Lengths >200 mm	73		79		85		91		97		103		109	
ANSI B18.2.3.1M	M24		(M27)		M30		(M33)		M36		(M39)		M42	
Lengths ≤125mm	54				66									
Lengths >125mm≤200mm	60				72				84				96	
Lengths >200 mm	73				85				97				109	

Width Across Flats s	(M45)		M48		(M52)		M56		(M60)		M64		M72	
Standard	min.	max.	min.	max.	min.	max.	min.	max.	min.	max.	min.	max.	min.	max.
DIN 931/933 (1987)	68.1	70.0	73.1	75.0	78.1	80.0	82.8	85.0	87.8	90.0	92.8	95.0	102.8	105.0
ISO 4014/4017 (1988)	68.1	70.0	73.1	75.0	78.1	80.0	82.8	85.0	87.8	90.0	92.8	95.0		

Head Height k	(M45)		M48		(M52)		M56		(M60)		M64		M72	
DIN 931/933 (1987)	27.58	28.42	29.58	30.42	32.50	33.50	34.50	35.50	37.50	38.50	39.50	40.50	44.50	45.50
ISO 4014/4017 (1988)	27.58	28.42	29.58	30.42	32.50	33.50	34.50	35.50	37.50	38.50	39.50	40.50		

Comparable Thread Lengths For DIN - ISO - ANSI														
DIN 931	(M45)		M48		(M52)		M56		(M60)		M64		M72	
Lengths ≤125mm	96		102											
Lengths >125mm≤200mm	102		108		116		124		132		140		156	
Lengths >200 mm	115		121		129		137		145		153		169	
ISO 4014	(M45)		M48		(M52)		M56		(M60)		M64		M72	
Lengths ≤125mm														
Lengths >125mm≤200mm	102		108		116									
Lengths >200 mm	115		121		129		137		145		153			
ANSI B18.2.3.1M	(M45)		M48		(M52)		M56		(M60)		M64		M72	
Lengths ≤125mm														
Lengths >125mm≤200mm			108											
Lengths >200 mm			121				137				153		169	

Property Class	8.8≤d 16mm		8.8≥d 16mm		10.9		A2 / A4-50		A2 / A4-70		A2 / A4-80	
Tensile Strength	116000 psi		120350 psi		150800 psi		72500 psi		101500 psi		116000 psi	
Yield Strength	92800 psi		95700 psi		136300 psi		30450 psi		65250 psi		87000 psi	
Rockwell Hardness (HRC)	min.	max.	min.	max.	min.	max.	min.	max.	min.	max.	min.	max.
	22	32	23	34	32	39	NA	NA	NA	NA	NA	NA

Property Class	Steel		Stainless Steel	
	8.8 & 10.9		A2 & A4	
Finish	Furnace Black	Plated	Plain	
Thread Tolerance	6g		6h	

FOR MORE DETAILED INFORMATION, PLEASE REFER TO COMPLETE DIN, ISO, JIS OR ANSI STANDARD, WHICH ARE THE GOVERNING STANDARDS

DIN 931/933 (1987) / ISO 4014/4017 (1988) / JIS B1180 (1977) / ANSI B 18.2.3.1M (1979) - LFG 10/01/2016 REVISED



Get quote >>

Angic Global Solutions

1-888-872-0690 Rights Reserved

<https://www.AngicGlobal.com> Sales@AngicGlobal.com

HEX HEAD CAP SCREWS - COURSE PITCH ▪ DIN 931/933 / ISO 4014/4017 / JIS B1180 / ANSI B 18.2.3.1M

For Screws Not Fully Threaded, The Thread Length Shown Is Minimum

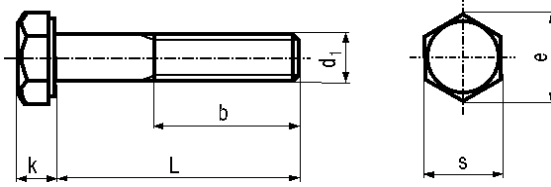

DIN 931 / ISO 4014 Partial Thread
DIN 933 / ISO 4017 Full Thread

Length Tolerance Product Grade Nominal Length L	DIN 931 / 933				ISO 4014 / 4017			
	A		B		A		B	
	min.	max.	min.	max.	min.	max.	min.	max.
6	5.76	6.24			5.76	6.24		
8	7.71	8.29			7.71	8.29		
10	9.71	10.29			9.71	10.29		
12	11.65	12.35			11.65	12.35		
(14)	13.65	14.35						
16	15.65	16.35			15.65	16.35		
(18)	17.65	18.35						
20	19.58	20.42			19.58	20.42		
(22)	21.58	22.42						
25	24.58	25.42			24.58	25.42		
(28)	27.58	28.42						
30	29.58	30.42			29.58	30.42		
35	34.50	35.50			34.50	35.50		
40	39.50	40.50			39.50	40.50		
45	44.50	45.50			44.50	45.50		
50	49.50	50.50			49.50	50.50		
55	54.40	55.60			54.40	55.60		
60	59.40	60.60			59.40	60.60		
65	64.40	65.60			64.40	65.60		
70	69.40	70.60			69.40	70.60		
(75)	74.40	75.60						
80	79.40	80.60			79.40	80.60		
(85)	84.30	85.70						
90	89.30	90.70	88.25	91.75	89.30	90.70		
(95)	94.30	95.70	93.25	96.75				
100	99.30	100.70	98.25	101.75	99.30	100.70	98.25	100.75
110	109.30	110.70	108.25	111.75	109.30	110.70	108.25	111.75
120	119.30	120.70	118.25	121.75	119.30	120.70	118.25	121.75
130	129.20	130.80	128.00	132.00	129.20	130.80	128.00	132.00
140	139.20	140.80	138.00	142.00	139.20	140.80	138.00	142.00
150	149.20	150.80	148.00	152.00	149.20	150.80	148.00	152.00
160	159.20	160.80	158.00	162.00			158.00	162.00
(170)	169.20	170.80	168.00	172.00				
180	179.20	180.80	178.00	182.00			178.00	182.00
(190)	189.08	190.92	187.70	192.30				
200	199.08	200.92	197.70	202.30			197.70	202.30
220			217.70	222.30			217.70	222.30
240			237.70	242.30			237.70	242.30
260			257.40	262.60			257.40	262.60
280			277.40	282.60			277.40	282.60
300			297.40	302.60			297.40	302.60
320			317.15	322.85			317.15	322.85
340			337.15	342.85			337.15	342.85
360			357.15	362.85			357.15	362.85
380			377.15	382.85			377.15	382.85
400			397.15	402.85			397.15	402.85
420			416.85	423.15			416.85	423.15
440			436.85	443.15			436.85	443.15
460			456.85	463.15			456.85	463.15
480			476.85	483.15			476.85	483.15
500			496.85	503.15			496.85	503.15

JIS B 1180 Length Tolerance is the same as ISO 4014 / 4017 Product Grade A through 120 mm long.

Please contact your Lindstrom Service Center For ANSI Length Tolerance.

For Reference Point Only	
Diameter	Coarse Thread Pitch
M2	0.4
M3	0.5
M4	0.7
M5	0.8
M6	1
(M7)	1
M8	1.25
M10	1.5
M12	1.75
(M14)	2
M16	2
(M18)	2.5
M20	2.5
(M22)	2.5
M24	3
(M27)	3
M30	3.5
(M33)	3.5
M36	4
(M39)	4
M42	4.5
(M45)	4.5
M48	5
(M52)	5
M56	5.5
(M60)	5.5
M64	6
M72	6

In Metric language, you should not show the thread pitch if you are using coarse thread pitch.

Diameters & Lengths Shown in () are not recommended for new design.
 The major difference between DIN, ISO, JIS and ANSI is the smaller WAF.
 The JIS standard for hex heads is only available in M8, M10, and M12.
 With the exception of M8, M10, M12, M14 and M22 WAF, all standards are basically functional and interchangeable.
 Width across corners (e) is relative to Width Across Flats.
 The DIN standard is still the most widely accepted standard worldwide except for the US Automotive Industry.

FOR MORE DETAILED INFORMATION, PLEASE REFER TO COMPLETE DIN, ISO, JIS OR ANSI STANDARD, WHICH ARE THE GOVERNING STANDARDS

DIN 931/933 (1987) / ISO 4014/4017 (1988) / JIS B1180 (1977) / ANSI B 18.2.3.1M (1979) - LFG 10/01/2016 REVISED

HEX HEAD CAP SCREWS - FINE PITCH - DIN 960/961 / ISO 8765/8676 / JIS B1180

2.4 - HEX HEAD CAP SCREWS - FINE PITCH

For Screws Not Fully Threaded, The Thread Length Shown Is Minimum

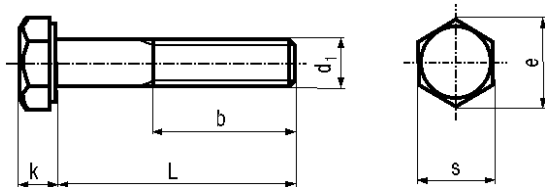

DIN 960 / ISO 8765 Partial Thread
DIN 961 / ISO 8675 Full Thread

Width Across Flats s	M8		M10		M12		(M14)		M16		(M18)		M20	
Fine Pitch	1		1.25		1.5		1.5		1.5		2		2	
Extra Fine Pitch			1		1.25		1.25		1		1.5		1.5	
Extra Extra Fine Pitch			0.75		1		1				1		1	
Standard	min.	max.	min.	max.	min.	max.	min.	max.	min.	max.	min.	max.	min.	max.
DIN 960/961 (1987)	12.73	13.00	16.73	17.00	18.67	19.00	21.67	22.00	23.67	24.00	26.67	27.00	29.67	30.00
ISO 8676/8765 (1988)	12.73	13.00	15.73	16.00	17.73	18.00	20.67	21.00	23.67	24.00	26.67	27.00	29.67	30.00
JIS B 1180 (1977)	11.75	12.00	13.75	14.00	16.65	17.00								

Head Height k	M8		M10		M12		(M14)		M16		(M18)		M20	
DIN 960/961 (1987)	5.150	5.450	6.220	6.580	7.320	7.680	8.620	8.980	9.820	10.180	11.280	11.720	12.280	12.720
ISO 8676/8765 (1988)	5.150	5.450	6.220	6.580	7.320	7.680	8.620	8.980	9.820	10.180	11.285	11.715	12.285	12.715
JIS B 1180 (1977)	5.350	5.650	6.800	7.200	7.800	8.200								

Comparable Thread Lengths For DIN - ISO - JIS - ANSI

DIN 960 (1987)	M8	M10	M12	(M14)	M16	(M18)	M20
Lengths ≤125mm	22	26	30	34	38	42	46
Lengths >125mm≤200mm	28	32	36	40	44	48	52
Lengths >200 mm	41	45	49	53	57	61	65
ISO 8765	M8	M10	M12	(M14)	M16	(M18)	M20
Lengths ≤125mm	22	26	30	34	38	42	46
Lengths >125mm≤200mm				40	44	48	52
Lengths >200 mm							
JIS 1180	M8	M10	M12	(M14)	M16	(M18)	M20
Lengths ≤125mm	22	26	30				
Lengths >125mm≤200mm							
Lengths >200 mm							

Width Across Flats s	(M22)		M24		(M27)		M30		(M33)		M36		(M39)	
Fine Pitch	2		2		2		3		3		3		3	
Extra Fine Pitch	1.5		1.5		1.5		2		2		2		2	
Extra Extra Fine Pitch	1		1		1		1.5		1.5		1.5		1.5	
Standard	min.	max.	min.	max.	min.	max.	min.	max.	min.	max.	min.	max.	min.	max.
DIN 960/961 (1987)	31.61	32.00	35.38	36.00	40.00	41.00	45.00	46.00	49.00	50.00	53.80	55.00	58.80	60.00
ISO 8676/8765 (1988)	33.38	34.00	35.38	36.00	40.00	41.00	45.00	46.00	49.00	50.00	53.80	55.00	58.80	60.00
Head Height k	(M22)		M24		(M27)		M30		(M33)		M36		(M39)	
DIN 960/961 (1987)	13.780	14.220	14.780	15.220	17.350	18.650	18.280	19.120	20.580	21.420	22.080	22.920	24.580	25.420
ISO 8676/8765 (1988)	13.785	14.215	14.785	15.215	16.650	17.350	18.280	19.120	20.580	21.420	22.080	22.920	24.580	25.420

Comparable Thread Lengths For DIN - ISO - JIS - ANSI

DIN 960 (1987)	(M22)	M24	(M27)	M30	(M33)	M36	(M39)
Lengths ≤125mm	50	54	60	66	72	78	84
Lengths >125mm≤200mm	56	60	66	72	78	84	90
Lengths >200 mm	69	73	79	85	91	97	103
ISO 8765	(M22)	M24	(M27)	M30	(M33)	M36	(M39)
Lengths ≤125mm	50	54	60	66			
Lengths >125mm≤200mm	56	60	66	72	78	84	90
Lengths >200 mm	69	73	79	85	91	97	103

FOR MORE DETAILED INFORMATION, PLEASE REFER TO COMPLETE DIN, ISO, OR JIS STANDARD, WHICH ARE THE GOVERNING STANDARDS

DIN 960/961 (1987) / ISO 8765/8676 (1988) / JIS B1180 (1977) - LFG 10/01/2016 REVISED

For Screws Not Fully Threaded, The Thread Length Shown Is Minimum

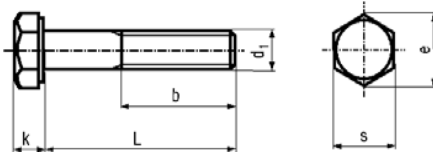

DIN 960 / ISO 8765 Partial Thread
DIN 961 / ISO 8675 Full Thread

Width Across Flats s	M42		(M45)		M48		(M52)		M56		(M60)		M64	
Fine Pitch	4		4		4		4		4		4		4	
Extra Fine Pitch	3		3		3		3		3		3		3	
Extra Extra Fine Pitch	2		2		2		2		2		2		2	
Standard	min.	max.	min.	max.	min.	max.	min.	max.	min.	max.	min.	max.	min.	max.
DIN 960/961 (1987)	63.1	65.0	68.1	70.0	73.1	75.0	78.1	80.0	82.8	85.0	87.8	90.0	92.8	95.0
ISO 8676/8765 (1988)	63.1	65.0	68.1	70.0	73.1	75.0	78.1	80.0	82.8	85.0	87.8	90.0	92.8	95.0
Head Height k	M42		(M45)		M48		(M52)		M56		(M60)		M64	
DIN 960/961 (1987)	25.58	26.42	27.58	28.42	29.58	30.42	32.50	33.50	34.50	35.50	37.50	38.50	39.50	40.50
ISO 8676/8765 (1988)	25.58	26.42	27.58	28.42	29.58	30.42	32.50	33.50	34.50	35.50	37.50	38.50	39.50	40.50

Comparable Thread Lengths For DIN - ISO - JIS - ANSI														
DIN 960 (1987)	M42		(M45)		M48		(M52)		M56		(M60)		M64	
Lengths ≤125mm	90		96		102									
Lengths >125mm≤200mm	96		102		108		116		124		132		140	
Lengths >200 mm	109		115		121		129		137		145		153	
ISO 8765	M42		(M45)		M48		(M52)		M56		(M60)		M64	
Lengths ≤125mm														
Lengths >125mm≤200mm	96		102		108		116							
Lengths >200 mm	109		115		121		129		137		145		153	
Property Class	8.8≤d 16mm		8.8≥d 16mm		10.9		Property Class		Steel					
Tensile Strength	116000 psi		120350 psi		150800 psi		Property Class		8.8 & 10.9					
Yield Strength	92800 psi		95700 psi		136300 psi		Finish		Furnace Black					
Rockwell Hardness (HRC)	min.	max.	min.	max.	min.	max.	Thread Tolerance		6g					
	22	32	23	34	32	39								

Length Tolerance	DIN 960 / 961				ISO 8765 / 8675				JIS B 1180 Length Tolerance is the same as ISO 4014 / 4017 Product Grade A through 120 mm long.
Product Grade	A		B		A		B		
Nominal Length L	min.	max.	min.	max.	min.	max.	min.	max.	
35	34.500	35.500			34.50	35.50			
40	39.500	40.500			39.50	40.50			
45	44.500	45.500			44.50	45.50			
50	49.500	50.500			49.50	50.50			
55	54.400	55.600			54.40	55.60			
60	59.400	60.600			59.40	60.60			
65	64.400	65.600			64.40	65.60			
70	69.400	70.600			69.40	70.60			
(75)	74.400	75.600							
80	79.400	80.600			79.40	80.60			
(85)	84.300	85.700	83.25	86.75					
90	89.300	90.700	88.25	91.75	89.30	90.70	88.25	91.75	
(95)	94.300	95.700	93.25	96.75					
100	99.300	100.700	98.25	101.75	99.30	100.70	98.25	100.75	
110	109.300	110.700	108.25	111.75	109.30	110.70	108.25	111.75	
120	119.300	120.700	118.25	121.75	119.30	120.70	118.25	121.75	
130	129.200	130.800	128.00	132.00	129.20	130.80	128.00	132.00	
140	139.200	140.800	138.00	142.00	139.20	140.80	138.00	142.00	
150	149.200	150.800	148.00	152.00	149.20	150.80	148.00	152.00	
160	159.200	160.800	158.00	162.00	159.20	160.80	158.00	162.00	
(170)	169.200	170.800	168.00	172.00					
180	179.200	180.800	178.00	182.00	179.20	180.80	178.00	182.00	
(190)	189.075	190.925	187.70	192.30					
200	199.075	200.925	197.70	202.30	199.08	200.92	197.70	202.30	
220			217.70	222.30			217.70	222.30	
240			237.70	242.30			237.70	242.30	
260			257.40	262.60			257.40	262.60	
280			277.40	282.60			277.40	282.60	
300			297.40	302.60			297.40	302.60	
320			317.15	322.85			317.15	322.85	
340			337.15	342.85			337.15	342.85	
360			357.15	362.85			357.15	362.85	
380			377.15	382.85			377.15	382.85	
400			397.15	402.85			397.15	402.85	
420			416.85	423.15			416.85	423.15	
440			436.85	443.15			436.85	443.15	
460			456.85	463.15			456.85	463.15	
480			476.85	483.15			476.85	483.15	
500			496.85	503.15			496.85	503.15	

2.5 - HEX HEAD CAP SCREWS - FINE PITCH

FOR MORE DETAILED INFORMATION, PLEASE REFER TO COMPLETE DIN, ISO, OR JIS STANDARD, WHICH ARE THE GOVERNING STANDARDS

DIN 960/961 (1987) / ISO 8765/8676 (1988) / JIS B1180 (1977) - LFG 10/01/2016 REVISED



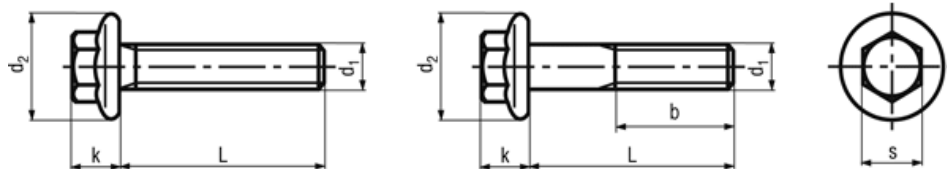

M6, M8, & M10 Diameters are also Available with a Serrated Flange

Thread Size d1	DIN 6921	M5	M6	M8	M10	M12	(M14)	M16	M20
Thread Pitch		0.8	1	1.25	1.5	1.75	2	2	2.5
Fine Pitch				1	1.25	1.5	1.5	1.5	1.5
Extra Fine Pitch					1	1.25			
DIN 6921 Thread Length b	For Lengths ≤125mm	16	18	22	26	30	34	38	46
	For Lengths >125mm≤200mm			28	32	36	40	44	52
	For Lengths >200 mm							57	65
DIN 6921 WAF s	min.	7.78	9.78	12.73	14.73	15.73	17.73	20.67	26.67
	max. = nominal	8.00	10.00	13.00	15.00	16.00	18.00	21.00	27.00
DIN 6921 Head Height To Include Flange k	max.	5.4	6.6	8.1	9.2	11.5	12.8	14.4	17.1
DIN 6921 Flange Diameter d2	max.	11.8	14.2	18.0	22.3	26.6	30.5	35.0	43.0

Thread Size d1	JIS B1189	M6	M8	M10
Thread Pitch		1	1.25	
Fine Pitch				1.25
JIS B1189 Thread Length b	For Lengths ≤125mm	18	22	26
	For Lengths >125mm≤200mm		28	32
JIS B 1189 WAF s	min.	9.80	11.75	13.75
	max. = nominal	10.00	12.00	14.00
JIS B 1189 Head Height To Include Flange k	max.	6.0	8.0	10.0
JIS B 1189 Flange Diameter d2	max.	14.0	17.5	21.0

JIS B1189 Availability Is Limited To The Diameters & Thread Pitches Shown Here.

Thread Size d1	ISO 4162	M5	M6	M8	M10	M12	(M14)	M16
Thread Pitch		0.8	1	1.25	1.5	1.75	2	2
Fine Pitch	ISO 4162 Does Not Recognize Fine Pitch Flange Screws							
ISO 4162 Thread Length b	For Lengths ≤125mm	16	18	22	26	30	34	38
	For Lengths >125mm≤200mm			28	32	36	40	44
	For Lengths >200 mm							57
ISO 4162 WAF s	min.	6.64	7.64	9.64	12.57	14.57	17.57	20.16
	max. = nominal	7.00	8.00	10.00	13.00	15.00	18.00	21.00
ISO 4162 Head Height To Include Flange k	max.	5.6	6.8	8.5	9.7	11.9	12.9	15.1
ISO 4162 Flange Diameter d2	max.	11.4	13.6	17.0	20.8	24.7	28.6	32.8

FOR MORE DETAILED INFORMATION, PLEASE REFER TO COMPLETE DIN OR JIS STANDARD, WHICH ARE THE GOVERNING STANDARDS

DIN 6921 (1983) / JIS B1189 (1977) / ISO 4162 (1990) / ASME-ANSI B18.2.3.4M (1995) / IFI 536 (1982) - LFG 10/01/2016 REVISED



Get quote >>

Angic Global Solutions

1-888-872-0690 Rights Reserved

<https://www.AngicGlobal.com> Sales@AngicGlobal.com

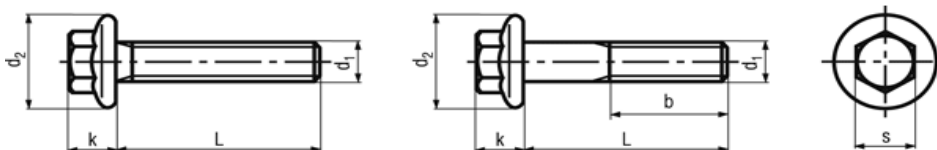

Thread Size d1	ASME-ANSI B18.2.3.4M	M5	M6	M8	M10	M12	(M14)	M16		
Thread Pitch		0.8	1	1.25	1.5	1.75	2	2		
Fine Pitch	ASME-ANSI B18.2.3.4M Does Not Recognize Fine Pitch Flange Screws									
ASME-ANSI B18.2.3.4M Thread Length b	ASME-ANSI B18.2.3.4M uses a shank length / grip length formula to determine thread length. - Refer to ASME- ANSI standard for more details.									
ASME-ANSI B18.2.3.4M WAF s	min.	6.64	7.64	9.64	12.57	14.57	17.57	20.16		
	max. = nominal	7.00	8.00	10.00	13.00	15.00	18.00	21.00		
ASME-ANSI B18.2.3.4M Head Height To Include Flange k	max.	5.6	6.9	8.5	9.7	12.1	12.9	15.2		
ASME-ANSI B18.2.3.4M Flange Diameter d2	max.	11.4	13.6	17.0	20.8	24.7	28.6	32.8		
Thread Size d1	IFI 536	M5	M6	M8	M10	M12	(M14)	M16		
Thread Pitch		0.8	1	1.25	1.5	1.75	2	2		
Fine Pitch	IFI 536 Does Not Recognize Fine Pitch Flange Screws									
IFI 536 Thread Length b	IFI 536 uses a shank length / grip length formula to determine thread length. - Refer to IFI standard for more details.									
IFI 536 WAF s	min.	6.64	7.64	9.64	12.57	14.57	17.57	20.48		
	max. = nominal	7.00	8.00	10.00	13.00	15.00	18.00	21.00		
IFI 536 Head Height To Include Flange k	max.	5.6	6.8	8.5	9.7	11.9	12.9	15.1		
IFI 536 Flange Diameter d2	max.	11.4	13.6	17.0	20.8	24.7	28.6	32.8		
Length Tolerance	DIN 6921		Length Tolerance							
Nominal Length	min.	max.	ISO 4162 / ASME-ANSI B18.2.3.4M Length Tolerance same as DIN 6921 through 160mm long.							
10	9.71	10.29	JIS B 1189 Length Tolerance same as DIN 6921 through 120mm long.							
12	11.65	12.35								
16	15.65	16.35								
20	19.58	20.42								
25	24.58	25.42								
30	29.58	30.42	IFI 536 Length Tolerance is similar to DIN 6921- Refer to IFI standard for more details.							
35	34.50	35.50	Diameters & Lengths With () are not recommended for new design.							
40	39.50	40.50								
45	44.50	45.50								
50	49.50	50.50								
(55)	54.40	55.60								
60	59.40	60.60	Thread Tolerance Plain 6g							
(65)	64.40	65.60	Thread Tolerance Plated 6h							
70	69.40	70.60	Thread Tolerance Stainless 6g							
80	79.40	80.60	Material	8.8 ≤ 16mm	8.8 > 16mm	10.9	A2 / A4-50	A2 / A4-70	A2 / A4-80	
90	89.30	90.70								
100	99.30	100.70	Finish				Furnace Black or Plated			
110	109.30	110.70	Tensile Strength		116000 psi	120350 psi	150800 psi	72500 psi	101500 psi	116000 psi
120	119.30	120.70	Yield Strength		92800 psi	95700 psi	136300 psi	30450 psi	65250 psi	87000 psi
130	129.20	130.80	Hardness		HRC 22-32	HRC 23-34	HRC 32-39	NA		
140	139.20	140.80								
150	149.20	150.80								
160	159.20	160.80								
180	179.20	180.80								
200	199.00	201.00								

FOR MORE DETAILED INFORMATION, PLEASE REFER TO COMPLETE DIN, JIS, ISO OR ASME-ANSI STANDARD, WHICH ARE THE GOVERNING STANDARDS

DIN 6921 (1983) / JIS B1189 (1977) / ISO 4162 (1990) / ASME-ANSI B18.2.3.4M (1995) / IFI 536 (1982) - LFG 10/01/2016 REVISED

HEX RIBBED FLANGE SCREWS (VERBUS RIPP®)

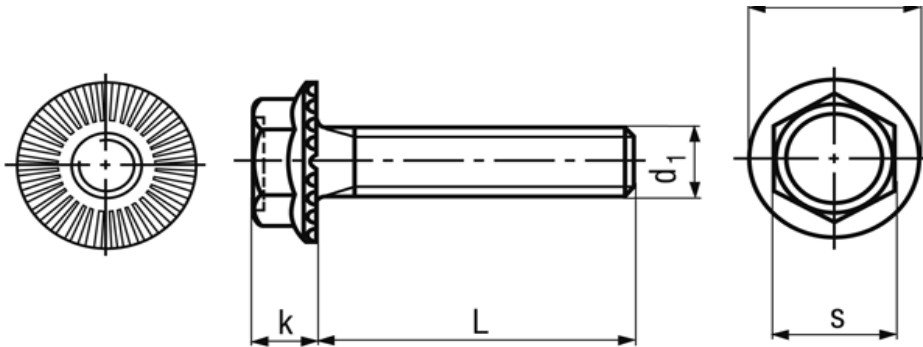

Thread Size d1		M5	M6	M8	M10	M12	M16
Thread Pitch		0.8	1	1.25	1.5	1.75	2
WAF s	min.	7.78	9.78	12.73	14.73	16.73	21.67
	max. = nominal	8.00	10.00	13.00	15.00	17.00	22.00
Head Height To Include Flange k	max.	4.3	5.5	7.0	8.5	10.0	14.0
Flange Diameter d2	max.	11.2	14.2	18.2	21.0	24.0	31.0
Normal Thread Length		16	18	22	26	30	38
Mechanical Properties							
Similar to		10.9					
Property Class		100					
Tensile Strength		150800-174000 psi					
Hardness		32-38 HRC					
Finish		Furnace Black					

HEX SERRATED FLANGE SCREWS

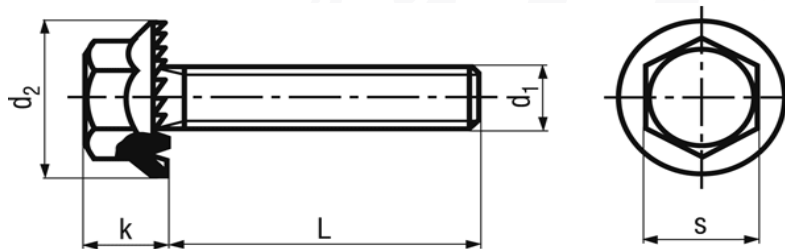

Thread Size d1		M5	M6	M8	M10	M12	M16
Thread Pitch		0.8	1	1.25	1.5	1.75	2
WAF s	min.	7.78	9.78	12.73	14.73	16.73	21.67
	max. = nominal	8.00	10.00	13.00	15.00	17.00	22.00
Head Height To Include Flange k	max.	4.3	5.5	7.0	7.9	8.7	11.2
Flange Diameter d2	max.	11.2	14.2	18.2	21.0	24.0	31.0
Normal Thread Length		16	18	22	26	30	38
Mechanical Properties		M5 Through M10				M12 & Up	
Similar to		9.8				10.9	
Property Class		90				100	
Tensile Strength		130500-159500 psi				150800-174000 psi	
Hardness		27-34 HRC				32-38 HRC	
Finish		Furnace Black				Furnace Black	

FOR MORE DETAILED INFORMATION, PLEASE REFER TO BAUER & SCHAURTE KARCHER SICHERUNGSSCHRAUBEN, WHICH IS THE GOVERNING STANDARD

BAUER & SCHAURTE - LFG 01/01/09 REVISED

FULL HEX NUTS ▪ DIN 934 / ISO 4032, STYLE 1 / JIS B 1181 / ANSI B 18.2.4.1M, STYLE 1

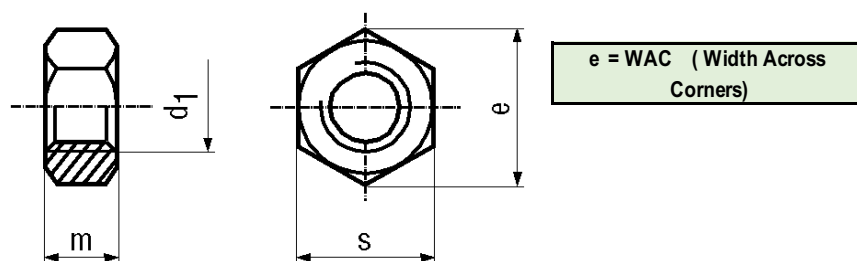

Thread Size d_1	1		1.2		1.4		1.6		2		2.5		3	
Coarse Pitch	0.25		0.25		0.3		0.35		0.4		0.45		0.5	
WAF s	min.	max.= nominal	min.	max.= nominal	min.	max.= nominal	min.	max.= nominal	min.	max.= nominal	min.	max.= nominal	min.	max.= nominal
DIN 934 (1987)	2.40	2.50	2.90	3.00	2.90	3.00	3.02	3.20	3.82	4.00	4.82	5.00	5.32	5.50
ISO 4032 (1986)							3.02	3.20	3.82	4.00	4.82	5.00	5.32	5.50
ANSI B 18.2.4.1M (1999)							3.02	3.20	3.82	4.00	4.82	5.00	5.32	5.50
Thickness m	min.	max.= nominal	min.	max.= nominal	min.	max.= nominal	min.	max.= nominal	min.	max.= nominal	min.	max.= nominal	min.	max.= nominal
DIN 934 (1987)	0.55	0.80	0.75	1.00	0.95	1.20	1.05	1.30	1.35	1.60	1.75	2.00	2.15	2.40
ISO 4032 (1986)							1.05	1.30	1.35	1.60	1.75	2.00	2.15	2.40
ANSI B 18.2.4.1M (1999)							1.05	1.30	1.35	1.60	1.75	2.00	2.15	2.40
WAC e	min.		min.		min.		min.		min.		min.		min.	
DIN 934 (1987)	2.71		3.28		3.28		3.41		4.32		5.45		6.01	
ISO 4032 (1986)							3.41		4.32		5.45		6.01	
ANSI B 18.2.4.1M (1999)							min.	max.	min.	max.	min.	max.	min.	max.
							3.41	3.70	4.32	4.62	5.45	5.77	6.01	6.35
Thread Size d_1	(3.5)		4		5		6		(7)		8		10	
Coarse Pitch	0.6		0.7		0.8		1		1		1.25		1.5	
Fine Pitch											1		1.25	
Extra Fine Pitch													1	
WAF s	min.	max.= nominal	min.	max.= nominal	min.	max.= nominal	min.	max.= nominal	min.	max.= nominal	min.	max.= nominal	min.	max.= nominal
DIN 934 (1987)	5.82	6.00	6.78	7.00	7.78	8.00	9.78	10.00	10.73	11.00	12.73	13.00	16.73	17.00
ISO 4032 (1986)	5.82	6.00	6.78	7.00	7.78	8.00	9.78	10.00			12.73	13.00	15.73	16.00
JIS 1181 (1985)											11.75	12.00	13.75	14.00
ANSI B 18.2.4.1M (1999)	5.82	6.00	6.78	7.00	7.78	8.00	9.78	10.00			12.73	13.00	15.73	16.00
Thickness m	min.	max.= nominal	min.	max.= nominal	min.	max.= nominal	min.	max.= nominal	min.	max.= nominal	min.	max.= nominal	min.	max.= nominal
DIN 934 (1987)	2.55	2.80	2.90	3.20	3.70	4.00	4.70	5.00	5.20	5.50	6.14	6.50	7.64	8.00
ISO 4032 (1986)	2.55	2.80	2.90	3.20	4.40	4.70	4.90	5.20			6.44	6.80	8.04	8.40
JIS 1181 (1985)											6.14	6.50	7.64	8.00
ANSI B 18.2.4.1M (1999)	2.55	2.80	2.90	3.20	4.40	4.70	4.90	5.20			6.44	6.80	8.04	8.40
WAC e	min.		min.		min.		min.		min.		min.		min.	
DIN 934 (1987)	6.58		7.66		8.79		11.05		12.12		14.38		18.90	
ISO 4032 (1986)	6.58		7.66		8.79		11.05				14.38		17.77	
JIS 1181 (1985)											13.20		15.50	
ANSI B 18.2.4.1M (1999)	min.	max.	min.	max.	min.	max.	min.	max.	min.	max.	min.	max.	min.	max.
	6.58	6.93	7.66	8.08	8.79	9.24	11.05	11.55			14.38	15.01	17.77	18.45

FOR MORE DETAILED INFORMATION, PLEASE REFER TO COMPLETE DIN, ISO, JIS, OR ANSI STANDARD, WHICH ARE THE GOVERNING STANDARDS

DIN 934 (1987) / ISO 4032 STYLE 1 (1986) / JIS B 1181 (1985) / ANSI B 18.2.4.1M STYLE 1 (1999) - LFG

FULL HEX NUTS ▪ DIN 934 / ISO 4032, STYLE 1 / JIS B 1181 / ANSI B 18.2.4.1M, STYLE 1

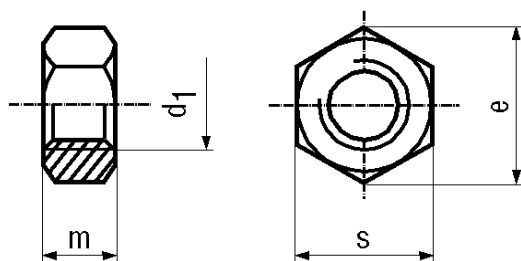

e = WAC (Width Across Corners)

Thread Size d_1	12		14		16		(18)		20		(22)		24	
Coarse Pitch	1.75		2		2		2.5		2.5		2.5		3	
Fine Pitch	1.5		1.5		1.5		2		2		2		2	
Extra Fine Pitch	1.25						1.5		1.5		1.5		1.5	
WAF s	min.	max.= nominal	min.	max.= nominal	min.	max.= nominal	min.	max.= nominal	min.	max.= nominal	min.	max.= nominal	min.	max.= nominal
DIN 934 (1987)	18.67	19.00	21.67	22.00	23.67	24.00	26.16	27.00	29.16	30.00	31.00	32.00	35.00	36.00
ISO 4032 (1986)	17.73	18.00	20.67	21.00	23.67	24.00	26.16	27.00	29.16	30.00	33.00	34.00	35.00	36.00
JIS 1181 (1985)	16.65	17.00												
ANSI B 18.2.4.1M (1999)	17.73	18.00	20.67	21.00	23.67	24.00			29.16	30.00			35.00	36.00

Thickness m	min.	max.= nominal	min.	max.= nominal	min.	max.= nominal	min.	max.= nominal	min.	max.= nominal	min.	max.= nominal	min.	max.= nominal
DIN 934 (1987)	9.64	10.00	10.30	11.00	12.30	13.00	14.30	15.00	14.90	16.00	16.90	18.00	17.70	19.00
ISO 4032 (1986)	10.37	10.80	12.10	12.80	14.10	14.80	15.10	15.80	16.90	18.00	18.10	19.40	20.20	21.50
JIS 1181 (1985)	9.64	10.00												
ANSI B 18.2.4.1M (1999)	10.37	10.80	12.10	12.80	14.10	14.80			16.90	18.00			20.20	21.50

WAC e	min.		min.		min.		min.		min.		min.		min.	
DIN 934 (1987)	21.10		24.49		26.75		29.56		32.95		35.03		39.55	
ISO 4032 (1986)	20.03		23.35		26.75		29.56		32.95		37.29		39.55	
JIS 1181 (1985)	18.80													
ANSI B 18.2.4.1M (1999)	min.	max.	min.	max.	min.	max.	min.	max.	min.	max.	min.	max.	min.	max.
	20.03	20.78	23.35	24.25	26.75	27.71			32.95	34.64			39.55	41.57

Thread Size d_1	(27)		30		(33)		36		(39)		42		(45)	
Coarse Pitch	3		3.5		3.5		4		4		4.5		4.5	
Fine Pitch	2		2		2		3		3		3		3	
WAF s	min.	max.= nominal	min.	max.= nominal	min.	max.= nominal	min.	max.= nominal	min.	max.= nominal	min.	max.= nominal	min.	max.= nominal
DIN 934 (1987)	40.0	41.0	45.0	46.0	49.0	50.0	53.8	55.0	58.8	60.0	63.1	65.0	68.1	70.0
ISO 4032 (1986)	40.0	41.0	45.0	46.0	49.0	50.0	53.8	55.0	58.8	60.0	63.1	65.0	68.1	70.0
ANSI B 18.2.4.1M (1999)			45.0	46.0			53.8	55.0						

Thickness m	min.	max.= nominal	min.	max.= nominal	min.	max.= nominal	min.	max.= nominal	min.	max.= nominal	min.	max.= nominal	min.	max.= nominal
DIN 934 (1987)	20.7	22.0	22.7	24.0	24.7	26.0	27.4	29.0	29.4	31.0	32.4	34.0	34.4	36.0
ISO 4032 (1986)	22.5	23.8	24.3	25.6	27.4	28.7	29.4	31.0	31.8	33.4	32.4	34.0	34.4	36.0
ANSI B 18.2.4.1M (1999)			24.3	25.6			29.4	31.0						

WAC e	min.		min.		min.		min.		min.		min.		min.	
DIN 934 (1987)	45.20		50.85		55.37		60.79		66.44		71.30		76.95	
ISO 4032 (1986)	45.20		50.85		55.37		60.79		66.44		71.30		76.95	
ANSI B 18.2.4.1M (1999)	min.	max.	min.	max.	min.	max.	min.	max.	min.	max.	min.	max.	min.	max.
			50.85	53.12			60.79	63.51						

FOR MORE DETAILED INFORMATION, PLEASE REFER TO COMPLETE DIN, ISO, JIS, OR ANSI STANDARD, WHICH ARE THE GOVERNING STANDARDS

DIN 934 (1987) / ISO 4032 STYLE 1 (1986) / JIS B 1181 (1985) / ANSI B 18.2.4.1M STYLE 1 (1999) - LFG

FULL HEX NUTS ▪ DIN 934 / ISO 4032, STYLE 1 / JIS B 1181 / ANSI B 18.2.4.1M, STYLE 1

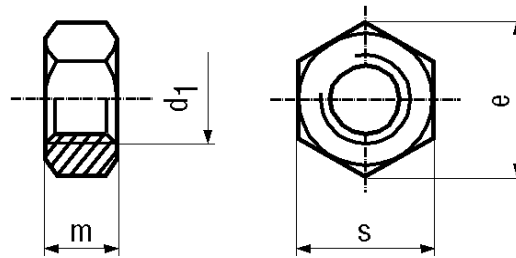

e = WAC (Width Across Corners)

Thread Size d1	48		(52)		56		(60)		64		(68)		72	
Coarse Pitch	5		5		5.5		5.5		6		6		6	
Fine Pitch	3		3		4		4		4		4		4	
WAF s	min.	max.= nominal	min.	max.= nominal	min.	max.= nominal	min.	max.= nominal	min.	max.= nominal	min.	max.= nominal	min.	max.= nominal
DIN 934 (1987)	73.1	75.0	78.1	80.0	82.8	85.0	87.8	90.0	92.8	95.0	97.8	100.0	102.8	105.0
ISO 4032 (1986)	73.1	75.0	78.1	80.0	82.8	85.0	87.8	90.0	92.8	95.0				

Thickness m	min.	max.= nominal	min.	max.= nominal	min.	max.= nominal	min.	max.= nominal	min.	max.= nominal	min.	max.= nominal	min.	max.= nominal
DIN 934 (1987)	36.4	38.0	40.4	42.0	43.4	45.0	46.4	48.0	49.1	51.0	52.1	54.0	56.1	58.0
ISO 4032 (1986)	36.4	38.0	40.4	42.0	43.4	45.0	46.4	48.0	49.1	51.0				

WAC e	min.		min.		min.		min.		min.		min.		min.	
DIN 934 (1987)	82.60		88.25		93.56		99.21		104.86		110.51		116.16	
ISO 4032 (1986)	82.60		88.25		93.56		99.21		104.86					

Thread Size d1	(76)		80		90		100		*****Notice*****					
Coarse Pitch	6		6		6		6		JIS 1181 Hex Nuts Only Available In Property Class 8, And In Sizes M8x1.25, M10x1.25, And M12x1.25, Except On Special Order.					
Fine Pitch	4		4		4		4							
WAF s	min.	max.= nominal	min.	max.= nominal	min.	max.= nominal	min.	max.= nominal						
DIN 934 (1987)	107.8	110.0	112.8	115.0	127.5	130.0	142.5	145.0	*****Notice*****					

Thickness m	min.	max.= nominal	min.	max.= nominal	min.	max.= nominal	min.	max.= nominal	The Strength Class Of The Nut Should Always Be Equal Or Greater Than The Strength Class Of The					
DIN 934 (1987)	59.1	61.0	62.1	64.0	70.1	72.0	78.1	80.0	*****Notice*****					

WAC e	min.		min.		min.		min.		Diameters with () & Fine Pitch Should Not Be Use For New Design.					
DIN 934 (1987)	121.81		127.46		144.08		161.02							

Material	Steel - Property Class							
Proof Load Stress psi	6		8		10		12	
up to M4	87000		116000		150800		166750	
M4 to M7	97150		117450		150800		166750	
M7 TO M10	98600		120350		150800		168200	
M10 TO M16	101500		121800		152250		172550	
M16 TO M39	104400		133400		153700		174000	
M39 TO M100	-		-		-		-	
Vickers Hardness HV	min.	max.	min.	max.	min.	max.	min.	max.
up to M4	150	302	170		272	353	295	353
M4 to M7			188	302				
M7 TO M10								
M10 TO M16			170	207				
M16 TO M39	170	207	-	-				
M39 TO M100	142	207	-	-				
Rockwell Hardness (min.)	~ B75		~ B80		~ C25		~ C30	
Finish	Plain or Plated							
Thread Tolerance	6H Plain or Plated							

Proof Load Stress (psi)	Stainless Steel A2 & A4	
Property Class 50	72500	
Property Class 70	101500	
Property Class 80	116000	
Hardness is not a measurable attribute of Stainless Steel		
Finish	Plain	
Thread Tolerance	6H	

Proof Load Stress (psi)	Brass	
Ms58	53650-65250	
Ms63	55100-69600	
Finish	Plain or Nickel Plated	
Thread Tolerance	6H	

FOR MORE DETAILED INFORMATION, PLEASE REFER TO COMPLETE DIN, ISO, JIS, OR ANSI STANDARD, WHICH ARE THE GOVERNING STANDARDS

DIN 934 (1987) / ISO 4032 STYLE 1 (1986) / JIS B 1181 (1985) / ANSI B 18.2.4.1M STYLE 1 (1999) - LFG

HEX JAM NUTS ▪ DIN 439B / ISO 4035 / ISO 8675 / ANSI B 18.2.4.5M

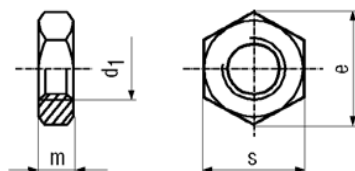

e = WAC (Width Across Corners)

3.4 - HEX JAM NUTS

Thread Size d1	1.6		2		2.5		3		(3.5)		4		5	
Coarse Pitch	0.35		0.4		0.45		0.5		0.6		0.7		0.8	
WAF s	min.	max.= nominal	min.	max.= nominal	min.	max.= nominal	min.	max.= nominal	min.	max.= nominal	min.	max.= nominal	min.	max.= nominal
DIN 439B (1987)	3.02	3.20	3.82	4.00	4.82	5.00	5.32	5.50	5.82	6.00	6.78	7.00	7.78	8.00
ISO 4035 (1986) / ISO 8675 (1988)	3.02	3.20	3.82	4.00	4.82	5.00	5.32	5.50	5.82	6.00	6.78	7.00	7.78	8.00
ANSI B 18.2.4.5M (1990)													7.78	8.00

Thickness m	min.	max.= nominal	min.	max.= nominal	min.	max.= nominal	min.	max.= nominal	min.	max.= nominal	min.	max.= nominal	min.	max.= nominal
DIN 439B (1987)	0.75	1.00	0.95	1.20	1.35	1.60	1.55	1.80	1.75	2.00	1.95	2.20	2.45	2.70
ISO 4035 (1986) / ISO 8675 (1988)	0.75	1.00	0.95	1.20	1.35	1.60	1.55	1.80	1.75	2.00	1.95	2.20	2.45	2.70
ANSI B 18.2.4.5M (1990)													2.45	2.70

WAC e	min.		min.		min.		min.		min.		min.		min.	
DIN 439B (1987)	3.41		4.32		5.45		6.01		6.58		7.66		8.79	
ISO 4035 (1986) / ISO 8675 (1988)	3.41		4.32		5.45		6.01		6.58		7.66		8.79	
ANSI B 18.2.4.5M (1990)													min.	max.
													8.79	9.24

Thread Size d1	6		8		10		12		14		16		(18)	
Coarse Pitch	1		1.25		1.5		1.75		2		2		2.5	
Fine Pitch			1		1.25		1.5		1.5		1.5		2	
Extra Fine Pitch					1		1.25						1.5	
WAF s	min.	max.= nominal	min.	max.= nominal	min.	max.= nominal	min.	max.= nominal	min.	max.= nominal	min.	max.= nominal	min.	max.= nominal
DIN 439B (1987)	9.78	10.00	12.73	13.00	16.73	17.00	18.67	19.00	21.67	22.00	23.67	24.00	26.16	27.00
ISO 4035 (1986) / ISO 8675 (1988)	9.78	10.00	12.73	13.00	15.73	16.00	17.73	18.00	20.67	21.00	23.67	24.00	26.16	27.00
ANSI B 18.2.4.5M (1990)	9.78	10.00	12.73	13.00	15.73	16.00	17.73	18.00	20.67	21.00	23.67	24.00		

Thickness m	min.	max.= nominal	min.	max.= nominal	min.	max.= nominal	min.	max.= nominal	min.	max.= nominal	min.	max.= nominal	min.	max.= nominal
DIN 439B (1987)	2.90	3.20	3.70	4.00	4.70	5.00	5.70	6.00	6.42	7.00	7.42	8.00	8.42	9.00
ISO 4035 (1986) / ISO 8675 (1988)	2.90	3.20	3.70	4.00	4.70	5.00	5.70	6.00	6.42	7.00	7.42	8.00	8.42	9.00
ANSI B 18.2.4.5M (1990)	2.90	3.20	3.70	4.00	4.70	5.00	5.70	6.00	6.64	7.00	7.64	8.00		

WAC e	min.		min.		min.		min.		min.		min.		min.	
DIN 439B (1987)	11.05		14.38		18.90		21.10		24.49		26.75		29.56	
ISO 4035 (1986) / ISO 8675 (1988)	11.05		14.38		17.77		20.03		23.35		26.75		29.56	
ANSI B 18.2.4.5M (1990)	min.	max.	min.	max.	min.	max.	min.	max.	min.	max.	min.	max.	min.	max.
	11.05	11.55	14.38	15.01	17.77	18.48	20.03	20.78	23.35	24.25	26.75	27.71		

DIN 439B Applies To Both Coarse & Fine Pitch Hex Jam Nuts	Diameters with () & Fine Pitch Should Not Be Use For New Design.
ISO 4035 Applies To Coarse Pitch Hex Jam Nuts	
ISO 8675 Applies To Fine Pitch Hex Jam Nuts	
ANSI B18.2.4.5M Does Not Recognize Fine Pitch Hex Jam Nuts	

FOR MORE DETAILED INFORMATION, PLEASE REFER TO COMPLETE DIN, ISO, OR ANSI STANDARD, WHICH ARE THE GOVERNING STANDARDS

DIN 439B (1987) / ISO 4035 (1986) / ISO 8675 (1988) / ANSI B 18.2.4.5M (1990) - LFG 10/01/2016 REVISED

HEX JAM NUTS • DIN 439B / ISO 4035 / ISO 8675 / ANSI B 18.2.4.5M

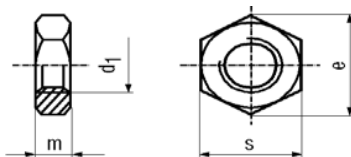

e = WAC (Width Across Corners)

Thread Size d1	20		(22)		24		(27)		30		(33)		36	
Coarse Pitch	2.5		2.5		3		3		3.5		3.5		4	
Fine Pitch	2		2		2		2		2		2		3	
Extra Fine Pitch	1.5		1.5		1.5		1.5		1.5		1.5		2	
Extra Extra Fine Pitch													1.5	
WAF s	min.	max.= nominal	min.	max.= nominal	min.	max.= nominal	min.	max.= nominal	min.	max.= nominal	min.	max.= nominal	min.	max.= nominal
DIN 439B (1987)	29.16	30.00	31.00	32.00	35.00	36.00	40.00	41.00	45.00	46.00	49.00	50.00	53.80	55.00
ISO 4035 (1986) / ISO 8675 (1988)	29.16	30.00	33.00	34.00	35.00	36.00	40.00	41.00	45.00	46.00	49.00	50.00	53.80	55.00
ANSI B 18.2.4.5M (1990)	29.16	30.00			35.00	36.00			45.00	46.00			53.80	55.00
Thickness m	min.	max.= nominal	min.	max.= nominal	min.	max.= nominal	min.	max.= nominal	min.	max.= nominal	min.	max.= nominal	min.	max.= nominal
DIN 439B (1987)	9.10	10.00	9.90	11.00	10.90	12.00	12.40	13.50	13.90	15.00	15.40	16.50	16.90	18.00
ISO 4035 (1986) / ISO 8675 (1988)	9.10	10.00	9.90	11.00	10.90	12.00	12.40	13.50	13.90	15.00	15.40	16.50	16.90	18.00
ANSI B 18.2.4.5M (1990)	9.42	10.00			11.30	12.00			14.30	15.00			17.30	18.00
WAC e	min.		min.		min.		min.		min.		min.		min.	
DIN 439B (1987)	32.95		35.03		39.55		45.20		50.85		55.37		60.79	
ISO 4035 (1986) / ISO 8675 (1988)	32.95		37.29		39.55		45.20		50.85		55.37		60.79	
ANSI B 18.2.4.5M (1990)	min.	max.			min.	max.			min.	max.			min.	max.
	32.95	34.64			39.55	41.57			50.85	53.12			60.79	63.51
Thread Size d1	(39)		42		(45)		48		(52)		56		64	
Coarse Pitch	4		4.5		4.5		5		5		5.5		6	
Fine Pitch	3		3		3		3		3		4		4	
Extra Fine Pitch	2		2		2		2		2					
Extra Extra Fine Pitch	1.5		1.5		1.5		1.5		1.5					
WAF s	min.	max.= nominal	min.	max.= nominal	min.	max.= nominal	min.	max.= nominal	min.	max.= nominal	min.	max.= nominal	min.	max.= nominal
DIN 439B (1987)	58.8	60.0	63.1	65.0	68.1	70.0	73.1	75.0	78.1	80.0				
ISO 4035 (1986) / ISO 8675 (1988)	58.8	60.0	63.1	65.0	68.1	70.0	73.1	75.0	78.1	80.0	82.8	85.0	92.8	95.0
Thickness m	min.	max.= nominal	min.	max.= nominal	min.	max.= nominal	min.	max.= nominal	min.	max.= nominal	min.	max.= nominal	min.	max.= nominal
DIN 439B (1987)	18.2	19.5	19.7	21.0	21.2	22.5	22.7	24.0	24.7	26.0				
ISO 4035 (1986) / ISO 8675 (1988)	18.2	19.5	19.7	21.0	21.2	22.5	22.7	24.0	24.7	26.0	26.7	28.0	30.4	32.0
WAC e	min.		min.		min.		min.		min.		min.		min.	
DIN 439B (1987)	66.44		71.30		76.95		82.60		88.25					
ISO 4035 (1986) / ISO 8675 (1988)	66.44		71.30		76.95		82.60		88.25		93.56		104.86	
Mechanical Properties														
Material	Steel - Property Class 04				Proof Load	Stainless Steel A2 & A4				Proof Load	Brass			
Diameter	Proof Load Stress (psi)	Vickers Hardness HV		min.	max.	Stress (psi)	Property Class 50		72500	Proof Load Stress (psi)	Ms58		53650-65250	
							Property Class 70				101500	Ms63		55100-69600
up to M4	55100	188	302	Hardness is not a measurable attribute of Stainless Steel				Hardness is not a measurable attribute of Brass						
M4 to M7				Finish				Plain or Nickel Plated						
M7 TO M10				Steel										
M10 TO M16				Plain										
M16 TO M39														
M39 TO M100														
Rockwell Hardness (min.)	~ B90				Thread Tolerance For All Jam Nuts, Steel Plain Or Plated, Stainless Steel, And Brass Is 6H									
Finish	Plain or Plated													

FOR MORE DETAILED INFORMATION, PLEASE REFER TO COMPLETE DIN, ISO, OR ANSI STANDARD, WHICH ARE THE GOVERNING STANDARDS

DIN 439B (1987) / ISO 4035 (1986) / ISO 8675 (1988) / ANSI B 18.2.4.5M (1990) - LFG 10/01/2016 REVISED

NYLON INSERT LOCK NUTS - DIN 985 / ISO 7040 / ANSI B 18.16.3M

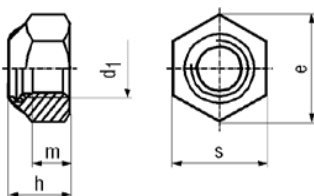

e = WAC (Width Across Corners)

**Nylon Temperature Range
- 58° to + 250° F**

3.6 - NYLON INSERT LOCK NUTS

Thread Size d1	(2)**		(2.5)**		(2.6)**		3		(3.5)**		4		5	
Coarse Pitch	0.4		0.45		0.45		0.5		0.6		0.7		0.8	
WAF s	min.	max.= nominal	min.	max.= nominal	min.	max.= nominal	min.	max.= nominal	min.	max.= nominal	min.	max.= nominal	min.	max.= nominal
DIN 985 (1987)	3.82	4.00	4.82	5.00	4.82	5.00	5.32	5.50	5.82	6.00	6.78	7.00	7.78	8.00
ISO 7040 (1997)							5.32	5.50			6.78	7.00	7.78	8.00
ANSI B 18.16.3M (1998)							5.32	5.50	5.82	6.00	6.78	7.00	7.78	8.00
Overall Height h	min.	max.= nominal	min.	max.= nominal	min.	max.= nominal	min.	max.= nominal	min.	max.= nominal	min.	max.= nominal	min.	max.= nominal
DIN 985 (1987)	2.55	2.80	3.55	3.80	3.55	3.80	3.70	4.00	4.20	4.50	4.70	5.00	4.70	5.00
ISO 7040 (1997)							4.02	4.50			5.52	6.00	6.22	6.80
ANSI B 18.16.3M (1998)							3.90	4.50	4.30	5.00	5.30	6.00	6.00	6.80
Wrenching Height m	min.		min.		min.		min.		min.		min.		min.	
DIN 985 (1987)	1.60		2.00		2.00		2.40		2.60		2.90		3.20	
ISO 7040 (1997)							1.72				2.32		3.52	
ANSI B 18.16.3M (1998)							1.40		1.70		1.90		2.70	
WAC e	min.		min.		min.		min.		min.		min.		min.	
DIN 985 (1987)	4.32		5.45		5.45		6.01		6.58		7.66		8.79	
ISO 7040 (1997)							6.01				7.66		8.79	
ANSI B 18.16.3M (1998)							min.	max.	min.	max.	min.	max.	min.	max.
							6.01	6.35	6.58	6.93	7.66	8.08	8.79	9.24
Thread Size d1	6		(7)		8		10		12		14		16	
Coarse Pitch	1		1		1.25		1.5		1.75		2		2	
Fine Pitch					1		1.25		1.5		1.5		1.5	
Extra Fine Pitch							1		1.25					
WAF s	min.	max.= nominal	min.	max.= nominal	min.	max.= nominal	min.	max.= nominal	min.	max.= nominal	min.	max.= nominal	min.	max.= nominal
DIN 985 (1987)	9.78	10.00	10.73	11.00	12.73	13.00	16.73	17.00	18.67	19.00	21.67	22.00	23.67	24.00
ISO 7040 (1997)	9.78	10.00			12.73	13.00	15.73	16.00	17.73	18.00	20.67	21.00	23.67	24.00
ANSI B 18.16.3M (1998)	9.78	10.00			12.73	13.00	15.73	16.00	17.73	18.00	20.67	21.00	23.67	24.00
Overall Height h	min.	max.= nominal	min.	max.= nominal	min.	max.= nominal	min.	max.= nominal	min.	max.= nominal	min.	max.= nominal	min.	max.= nominal
DIN 985 (1987)	5.70	6.00	7.14	7.50	7.64	8.00	9.64	10.00	11.57	12.00	13.30	14.00	15.30	16.00
ISO 7040 (1997)	7.42	8.00			8.92	9.50	11.20	11.90	14.20	14.90	15.90	17.00	17.80	19.10
ANSI B 18.16.3M (1998)	7.20	8.00			8.50	9.50	10.90	11.90	13.90	14.90	15.80	17.00	17.90	19.10
Wrenching Height m	min.		min.		min.		min.		min.		min.		min.	
DIN 985 (1987)	4.00		4.70		5.50		6.50		8.00		9.50		10.50	
ISO 7040 (1997)	3.92				5.15		6.43		8.30		9.68		11.28	
ANSI B 18.16.3M (1998)	3.00				3.70		4.80		6.70		7.80		9.10	
WAC e	min.		min.		min.		min.		min.		min.		min.	
DIN 985 (1987)	11.05		12.12		14.38		18.90		21.10		24.49		26.75	
ISO 7040 (1997)	11.05				14.38		17.77		20.03		23.36		26.75	
ANSI B 18.16.3M (1998)	min.	max.	min.	max.	min.	max.	min.	max.	min.	max.	min.	max.	min.	max.
	11.05	11.55			14.38	15.01	17.77	18.48	20.03	20.78	23.35	24.25	26.75	27.71

M2, M2.5, M2.6, And M3.5 Not in DIN 985 Standard, But Dimensions As Shown. These Sizes Along With Other Sizes With () Should Not Be Used In New Designs.

The Strength Class Of The Nut Should Always Be Equal Or Greater Than The Strength Class Of The Screw.

Thread Tolerance For All Lock Nuts, Steel Plain Or Plated, Stainless Steel, Is 6H

FOR MORE DETAILED INFORMATION, PLEASE REFER TO COMPLETE DIN, ISO, OR ANSI STANDARD, WHICH ARE THE GOVERNING STANDARDS

DIN 985 (1987) / ISO 7040 (1997) / ANSI B 18.16.3M(1998) - LFG 10/01/2016 REVISED



Get quote »

Angic Global Solutions

1-888-872-0690 Rights Reserved

<https://www.AngicGlobal.com> Sales@AngicGlobal.com

NYLON INSERT LOCK NUTS • DIN 985 / ISO 7040 / ANSI B 18.16.3M

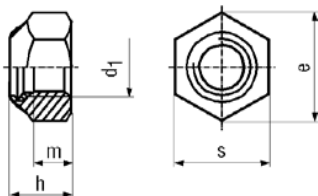

**e = WAC (Width Across
Corners)**

**Nylon Temperature Range
- 58° to + 250° F**

Thread Size d1	(18)		20		(22)		24		(27)		30		(33)			
Coarse Pitch	2.5		2.5		2.5		3		3		3.5		3.5			
Fine Pitch	2		2		2		2		2		2		2			
Extra Fine Pitch	1.5		1.5		1.5											
WAF s	min.	max.= nominal	min.	max.= nominal	min.	max.= nominal	min.	max.= nominal	min.	max.= nominal	min.	max.= nominal	min.	max.= nominal		
DIN 985 (1987)	26.16	27.00	29.16	30.00	31.00	32.00	35.00	36.00	40.00	41.00	45.00	46.00	49.00	50.00		
ISO 7040 (1997)			29.16	30.00			35.00	36.00			45.00	46.00				
ANSI B 18.16.3M (1998)			29.16	30.00			35.00	36.00			45.00	46.00				
Overall Height h	min.	max.= nominal	min.	max.= nominal	min.	max.= nominal	min.	max.= nominal	min.	max.= nominal	min.	max.= nominal	min.	max.= nominal		
DIN 985 (1987)	17.66	18.50	18.70	20.00	20.70	22.00	22.70	24.00	25.70	27.00	28.70	30.00	31.40	33.00		
ISO 7040 (1997)			20.70	22.80			25.00	27.10			30.10	32.60				
ANSI B 18.16.3M (1998)			21.50	22.80			25.60	27.10			30.60	32.60				
Wrenching Height m	min.		min.		min.		min.		min.		min.		min.			
DIN 985 (1987)	13.00		14.00		15.00		15.00		17.00		19.00		22.00			
ISO 7040 (1997)			13.52				16.16				19.44					
ANSI B 18.16.3M (1998)			10.90				13.00				15.70					
WAC e	min.		min.		min.		min.		min.		min.		min.			
DIN 985 (1987)	29.56		32.95		35.03		39.55		45.20		50.85		55.37			
ISO 7040 (1997)			32.95				39.55				50.85					
ANSI B 18.16.3M (1998)	min.	max.	min.	max.	min.	max.	min.	max.	min.	max.	min.	max.	min.	max.		
			32.95	34.64			39.55	41.57			50.85	53.12				
Thread Size d1	36		(39)		42		(45)		48							
Coarse Pitch	4		4		4.5		4.5		5							
Fine Pitch	3		3		3		3		3							
WAF s	min.	max.= nominal	min.	max.= nominal	min.	max.= nominal	min.	max.= nominal	min.	max.= nominal						
DIN 985 (1987)	53.8	55.0	58.8	60.0	63.8	65.0	68.1	70.0	73.1	75.0						
ISO 7040 (1997)	53.8	55.0														
ANSI B 18.16.3M (1998)	53.8	55.0														
Overall Height h	min.	max.= nominal	min.	max.= nominal	min.	max.= nominal	min.	max.= nominal	min.	max.= nominal						
DIN 985 (1987)	34.4	36.0	37.4	39.0	40.4	42.0	43.4	45.0	46.4	48.0						
ISO 7040 (1997)	36.4	38.9														
ANSI B 18.16.3M (1998)	36.9	38.9														
Wrenching Height m	min.		min.		min.		min.		min.							
DIN 985 (1987)	25.00		27.00		29.00		32.00		36.00							
ISO 7040 (1997)	23.52															
ANSI B 18.16.3M (1998)	19.00															
WAC e	min.		min.		min.		min.		min.							
DIN 985 (1987)	60.79		66.44		72.09		76.95		82.60							
ISO 7040 (1997)	60.79															
ANSI B 18.16.3M (1998)	min.	max.														
	60.79	63.51														
Stainless Steel A2 & A4																
Proof Load Stress (psi)											Property Class 50	72500				
											Property Class 70	101500				
											Property Class 80	116000				
Hardness is not a measurable attribute of Stainless Steel																
Finish	Plain															
Steel - Property Class																
Material	6		8		10		Vickers Hardness HV		6		8		10			
Proof Load Stress (psi)									min.	max.	min.	max.	min.	max.		
up to M4	87000		116000		150800		up to M4		150	302	170		272	353		
M4 to M7	97150		117450		150800		M4 to M7				188				302	
M7 TO M10	98600		120350		150800		M7 TO M10				233				353	
M10 TO M16	101500		121800		152250		M10 TO M16				207					
M16 TO M39	104400		133400		153700		M16 TO M39									
M39 TO M100	-		-		-		M39 TO M100									
Finish	Plain or Plated															
Thread Tolerance	6H															

3.7 - NYLON INSERT LOCK NUTS

FOR MORE DETAILED INFORMATION, PLEASE REFER TO COMPLETE DIN, ISO, OR ANSI STANDARD, WHICH ARE THE GOVERNING STANDARDS

DIN 985 (1987) / ISO 7040 (1997) / ANSI B 18.16.3M(1998) - LFG 10/01/2016 REVISED



Get quote >>

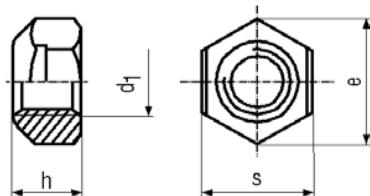

e = WAC (Width Across Corners)

Temperature Range
- 58° to + 440° F

3.8 - ALL-METAL LOCK NUTS

Thread Size d1	3		3.5**		4		5		6		(7)		8	
Coarse Pitch	0.5		0.7		0.7		0.8		1		1		1.25	
Fine Pitch													1	
WAF s	min.	max.= nominal	min.	max.= nominal	min.	max.= nominal	min.	max.= nominal	min.	max.= nominal	min.	max.= nominal	min.	max.= nominal
DIN 980V (1987)	5.32	5.50			6.78	7.00	7.78	8.00	9.78	10.00	10.73	11.00	12.73	13.00
ISO 7719 (1997)							7.78	8.00	9.78	10.00			12.73	13.00
ANSI B 18.16.3M (1998)	5.32	5.50	5.82	6.00	6.78	7.00	7.78	8.00	9.78	10.00			12.73	13.00
Overall Height h	min.	max.= nominal	min.	max.= nominal	min.	max.= nominal	min.	max.= nominal	min.	max.= nominal	min.	max.= nominal	min.	max.= nominal
DIN 980V (1987)	3.40	3.70			3.90	4.20	4.80	5.10	5.70	6.00	6.50	7.00	7.50	8.00
ISO 7719 (1997)							4.80	5.30	5.40	5.90			6.44	7.10
ANSI B 18.16.3M (1998)	2.65	3.10	3.00	3.50	3.50	4.00	4.80	5.30	5.40	5.90			6.44	7.10
WAC e	min.		min.		min.		min.		min.		min.		min.	
DIN 980V (1987)	6.01				7.66		8.79		11.05		12.12		14.38	
ISO 7719 (1997)							8.79		11.05				14.38	
ANSI B 18.16.3M (1998)	min.	max.	min.	max.	min.	max.	min.	max.	min.	max.	min.	max.	min.	max.
	6.01	6.35	6.58	6.93	7.66	8.08	8.79	9.24	11.05	11.55			14.38	15.01
Thread Size d1	10		12		14		16		(18)		20		(22)	
Coarse Pitch	1.5		1.75		2		2		2.5		2.5		2.5	
Fine Pitch	1.25		1.5		1.5		1.5		2		2		2	
Extra Fine Pitch	1		1.25						1.5		1.5		1.5	
WAF s	min.	max.= nominal	min.	max.= nominal	min.	max.= nominal	min.	max.= nominal	min.	max.= nominal	min.	max.= nominal	min.	max.= nominal
DIN 980V (1987)	16.73	17.00	18.67	19.00	21.67	22.00	23.67	24.00	26.16	27.00	29.16	30.00	31.00	32.00
ISO 7719 (1997)	15.73	16.00	17.73	18.00	20.67	21.00	23.67	24.00	26.16	27.00	29.16	30.00	33.00	34.00
ANSI B 18.16.3M (1998)	15.73	16.00	17.73	18.00	20.67	21.00	23.67	24.00			29.16	30.00		
Overall Height h	min.	max.= nominal	min.	max.= nominal	min.	max.= nominal	min.	max.= nominal	min.	max.= nominal	min.	max.= nominal	min.	max.= nominal
DIN 980V (1987)	9.00	10.00	11.00	12.00	12.00	14.00	14.00	16.00	16.00	18.00	18.00	20.00	20.00	22.00
ISO 7719 (1997)	8.04	9.00	10.37	11.60	12.10	13.20	14.10	15.20	15.01	17.00	16.90	19.00	18.10	21.00
ANSI B 18.16.3M (1998)	8.04	9.00	10.37	11.60	12.10	13.20	14.10	15.20			16.90	19.00		
WAC e	min.		min.		min.		min.		min.		min.		min.	
DIN 980V (1987)	18.90		21.10		24.49		26.75		29.56		32.95		35.03	
ISO 7719 (1997)	17.77		20.03		23.36		26.75		29.56		32.95		37.29	
ANSI B 18.16.3M (1998)	min.	max.	min.	max.	min.	max.	min.	max.	min.	max.	min.	max.	min.	max.
	17.77	18.48	20.03	20.78	23.35	24.25	26.75	27.71			32.95	34.64		
Thread Size d1	24		(27)		30		(33)		36		(39)			
Coarse Pitch	3		3		3.5		3.5		4		4			
Fine Pitch	2		2		2		2		3		3			
WAF s	min.	max.= nominal	min.	max.= nominal	min.	max.= nominal	min.	max.= nominal	min.	max.= nominal	min.	max.= nominal	min.	max.= nominal
DIN 980V (1987)	35.0	36.0	40.0	41.0	45.0	46.0	49.0	50.0	53.8	55.0	58.8	60.0		
ISO 7719 (1997)	35.0	36.0			45.0	46.0			53.8	55.0				
ANSI B 18.16.3M (1998)	35.0	36.0			45.0	46.0			53.8	55.0				
Overall Height h	min.	max.= nominal	min.	max.= nominal	min.	max.= nominal	min.	max.= nominal	min.	max.= nominal	min.	max.= nominal	min.	max.= nominal
DIN 980 (1987)	22.0	24.0	25.0	27.0	28.0	30.0	31.0	33.0	34.0	36.0	37.0	39.0		
ISO 7719 (1997)	20.2	23.0			24.3	26.9			29.4	32.5				
ANSI B 18.16.3M (1998)	20.2	23.0			24.3	26.9			29.4	32.5				
WAC e	min.		min.		min.		min.		min.		min.		min.	
DIN 980V (1987)	39.55		45.20		50.85		55.37		60.79		66.44			
ISO 7719 (1997)	39.55				50.85				60.79					
ANSI B 18.16.3M (1998)	min.	max.	min.	max.	min.	max.	min.	max.	min.	max.	min.	max.	min.	max.
	39.55	41.57			50.85	53.12			60.79	63.51				

FOR MORE DETAILED INFORMATION, PLEASE REFER TO COMPLETE DIN, ISO, OR ANSI STANDARD, WHICH ARE THE GOVERNING STANDARDS

DIN 980V (1987) / ISO 7719 (1997) / ANSI B 18.16.3M (1998) - LFG 10/01/2016 REVISED

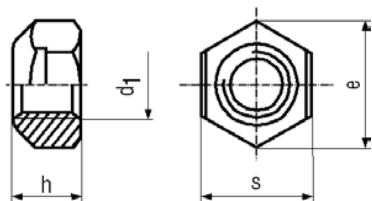

e = WAC (Width Across Corners)

Temperature Range
- 58° to + 440° F

M3.5 Is Not Listed In DIN Standard, And That Size Along With Sizes With () Should Not Be Used In New Designs.										
The Strength Class Of The Nut Should Always Be Equal Or Greater Than The Strength Class Of The Screw.										
Mechanical Properties										
Steel - Property Class										
Proof Load Stress psi	6	8	10	Vickers Hardness HV	6		8		10	
					min.	max.	min.	max.	min.	max.
up to M4	87000	116000	150800	up to M4	150	302	170	302	272	353
M4 to M7	97150	117450	150800	M4 to M7						
M7 TO M10	98600	120350	150800	M7 TO M10						
M10 TO M16	101500	121800	152250	M10 TO M16	170	207	233	353	272	353
M16 TO M39	104400	133400	153700	M16 TO M39						
M39 TO M100	-	-	-	M39 TO M100	142		207			
Finish	Plain or Plated									
Thread Tolerance	Plain or Plated 6H									

3.9 - ALL-METAL LOCK NUTS

FOR MORE DETAILED INFORMATION, PLEASE REFER TO COMPLETE DIN, ISO, OR ANSI STANDARD, WHICH ARE THE GOVERNING STANDARDS

DIN 980V (1987) / ISO 7719 (1997) / ANSI B 18.16.3M (1998) - LFG 10/01/2016 REVISED



Get quote »

HEX NUTS WITH EXTERNAL TOOTH LOCK WASHERS ATTACHED (KEPS®)

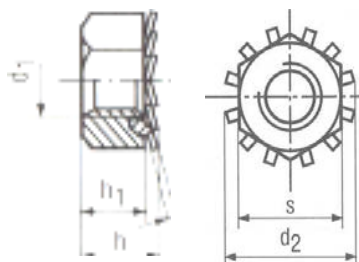

There Is No DIN, ISO, Or ANSI Standard Covering This Product, But Here Are The Dimensions To Which We Supply This Product.

Thread Size d1	3		4		5		6		8		10	
Coarse Pitch	0.5		0.7		0.8		1		1.25		1.5	
WAF s	min.	max.= nominal	min.	max.= nominal	min.	max.= nominal	min.	max.= nominal	min.	max.= nominal	min.	max.= nominal
Hex Nuts With External Tooth Lock Washers Attached	5.32	5.50	6.78	7.00	7.78	8.00	9.78	10.00	12.73	13.00	16.73	17.00
Nut Only Height h1	min.	max.= nominal	min.	max.= nominal	min.	max.= nominal	min.	max.= nominal	min.	max.= nominal	min.	max.= nominal
Hex Nuts With External Tooth Lock Washers Attached	2.15	2.40	2.90	3.20	3.70	4.00	4.70	5.00	6.14	6.50	7.64	8.00
Overall Height To Include Washer h	min.	max.= nominal	min.	max.= nominal	min.	max.= nominal	min.	max.= nominal	min.	max.= nominal	min.	max.= nominal
Hex Nuts With External Tooth Lock Washers Attached	max. 3.3		max. 4.1		max. 5.2		max. 6.2		max. 8.5		max. 9.7	
Washer OD d2												
Hex Nuts With External Tooth Lock Washers Attached	max. 7.1		max. 8.5		max. 9.5		max. 12		max. 15.5		max. 20.1	

Nut Material	Property Class 8	A2 Stainless Steel	Thread Tolerance For Steel & Stainless Steel Is 6H.
Washer Material	Spring Steel	A2 Stainless Steel	
Proof Load Stress psi	116000	72500	
Rockwell Hardness	~HRB 92.5-HRC 30	Not An Attribute Of Stainless Steel	
Finish	Zinc Plated	Plain	

LFG 01/01/2013 REVISED

HEX FLANGE NUTS - DIN 6923 / JIS B 1190 / ISO 4161 / ANSI B 18.2.4.4M

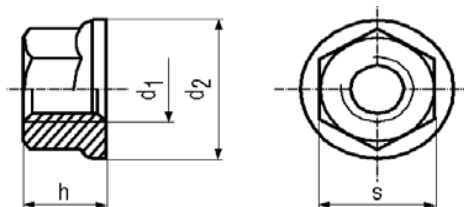

Thread Size d1	5		6		8		10			
Coarse Pitch	0.8		1		1.25		1.5			
					1		1.25			
							1			
WAF s	min.	max.= nominal	min.	max.= nominal	min.	max.= nominal	min.	max.= nominal		
DIN 6923 (1983)	7.78	8.00	9.78	10.00	12.73	13.00	14.73	15.00		
ISO 4161 (1983)	7.78	8.00	9.78	10.00	12.73	13.00	14.73	15.00		
JIS B 1190 (1977)			9.80	10.00	11.75	12.00	13.75	14.00		
ANSI B 18.2.4.4M (1993)	7.78	8.00	9.78	10.00	12.73	13.00	14.73	15.00		
Overall Height h	min.	max.	min.	max.	min.	max.	min.	max.		
DIN 6923 (1983)	4.70	5.00	5.70	6.00	7.60	8.00	9.64	10.00		
ISO 4161 (1983)	4.70	5.00	5.70	6.00	7.60	8.00	9.64	10.00		
JIS B 1190 (1977)			5.25	6.00	7.10	8.00	9.10	10.00		
ANSI B 18.2.4.4M (1993)	4.70	5.00	5.70	6.00	7.60	8.00	9.64	10.00		
Flange Diameter d2	max.		max.		max.		max.			
DIN 6923 (1983)	11.8		14.2		17.9		21.8			
ISO 4161 (1983)	11.8		14.2		17.9		21.8			
JIS B 1190 (1977)			14.0		17.5		21.0			
ANSI B 18.2.4.4M (1993)	11.8		14.2		17.9		21.8			
Thread Size d1	12		14		16		20			
Coarse Pitch	1.75		2		2		2.5			
Fine Pitch	1.5		1.5		1.5		1.5			
Extra Fine Pitch	1.25									
WAF s	min.	max.= nominal	min.	max.= nominal	min.	max.= nominal	min.	max.= nominal		
DIN 6923 (1983)	17.73	18.00	20.67	21.00	23.67	24.00	29.67	30.00		
ISO 4161 (1983)	17.73	18.00	20.67	21.00	23.67	24.00	29.16	30.00		
ANSI B 18.2.4.4M (1993)	17.73	18.00	20.67	21.00	23.67	24.00	29.16	30.00		
Overall Height h	min.	max.	min.	max.	min.	max.	min.	max.		
DIN 6923 (1983)	11.6	12.0	13.3	14.0	15.3	16.0	18.9	20.0		
ISO 4161 (1983)	11.6	12.0	13.3	14.0	15.3	16.0	18.9	20.0		
ANSI B 18.2.4.4M (1993)	11.6	12.0	13.3	14.0	15.3	16.0	18.9	20.0		
Flange Diameter d2	max.		max.		max.		max.			
DIN 6923 (1983)	26.0		29.9		34.5		42.8			
ISO 4161 (1983)	26.0		29.9		34.5		42.8			
ANSI B 18.2.4.4M (1993)	26.0		29.9		34.5		42.8			
Material	Steel - Property Class				Stainless Steel A2					
Proof Load (psi)	8		10		Proof Load (psi)	Property Class 50		72500		
M5 to M6	117450		150800			Property Class 70		101500		
M8 TO M10	120350		150800			Property Class 80		116000		
M10 TO M16	121800		152250		Hardness is not a measurable attribute of Stainless Steel					
M20	133400		153700							
Vickers Hardness HV	min.	max.	min.	max.	Finish	Plain				
M5 to M6	188	302	272	353	Thread Tolerance	6H				
M8 TO M10					JIS Only Available In M6 x 1, M8 x 1.25, And M10 x1.25, Except On Special Order.					
M10 TO M16										
M20	233	353	The Strength Class Of The Nut Should Always Be Equal Or Greater Than The Strength Class Of The Screw.							
Rockwell Hardnes (min)	~ B80								~ C25	
Finish	Plain or Plated									
Thread Tolerance	6H Plain or Plated									

FOR MORE DETAILED INFORMATION, PLEASE REFER TO COMPLETE DIN, JIS, ISO, OR ANSI STANDARD, WHICH ARE THE GOVERNING STANDARDS

DIN 6923 (1983) / JIS B 1190 (1977) / ISO 4161 (1983) / ANSI B 18.2.4.4M(1993) - LFG 10/01/16 REVISED

HEX NUTS WITH CONICAL SPRING WASHERS ATTACHED ▪ BN 1365

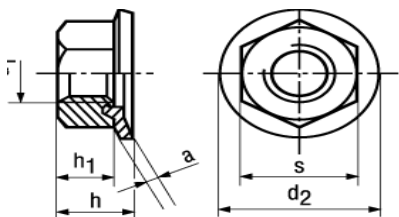

There is No DIN, ISO, Or ANSI Standard Covering This Product, But Here Are The Dimensions To Which We Supply This Product.

Thread Size d1	3		4		5		6		8		10		12	
Coarse Pitch	0.5		0.7		0.8		1		1.25		1.5		1.75	
WAF s	min.	max.= nominal	min.	max.= nominal	min.	max.= nominal	min.	max.= nominal	min.	max.= nominal	min.	max.= nominal	min.	max.= nominal
Hex Nuts With Conical Spring Washers Attached	5.32	5.50	6.78	7.00	7.78	8.00	9.78	10.00	12.73	13.00	16.73	17.00	18.73	19.00
Nut Only Height h1	min.	max.= nominal	min.	max.= nominal	min.	max.= nominal	min.	max.= nominal	min.	max.= nominal	min.	max.= nominal	min.	max.= nominal
Hex Nuts With Conical Spring Washers Attached	2.15	2.40	2.90	3.20	3.70	4.00	4.70	5.00	6.14	6.50	7.64	8.00	9.64	10.00
Overall Height To Include Washer h	min.	max.= nominal	min.	max.= nominal	min.	max.= nominal	min.	max.= nominal	min.	max.= nominal	min.	max.= nominal	min.	max.= nominal
Hex Nuts With Conical Spring Washers Attached	max. 3.8		max. 4.2		max. 5.3		max. 6.6		max. 8.8		max. 10.7		max. 13.8	
Washer OD d2														
Hex Nuts With Conical Spring Washers Attached	max. 8.0		max. 10.0		max. 12.0		max. 14.0		max. 18.0		max. 22.0		max. 25.5	
Nut Material	Property Class 8													
Washer Material	Spring Steel													
Proof Load Stress psi	116000													
Rockwell Hardness	~HRB 92.5-HRC 30													
Finish	Zinc Plated													
Thread Tolerance	6H													

FOR MORE DETAILED INFORMATION, PLEASE REFER TO BOSSARD BN 1365, WHICH IS THE GOVERNING STANDARD

LFG 10/01/2016

HEX COUPLING NUTS ▪ DIN 6334 (NOMINAL HEIGHT ~ 3 x DIAMETER)

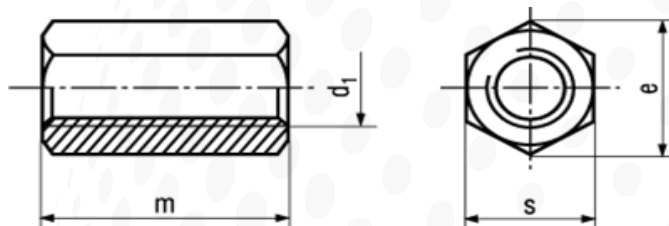

Thread Size d1	4	5	6	8	10	12	14	16	20	24	30
Coarse Pitch	0.07	0.08	1	1.25	1.5	1.75	2	2	2.5	3	3.5
WAF s	7	8	10	13	17	19	22	24	30	36	46
Height m	12	15	18	24	30	36	42	48	60	72	90
Material	Free Cutting Steel										
Rockwell Hardness	Not Rated For Hardness										
Finish	Zinc Plated										
Thread Tolerance	6H										

FOR MORE DETAILED INFORMATION, PLEASE REFER TO DIN 9334, WHICH IS THE GOVERNING STANDARD

LFG 10/01/2016

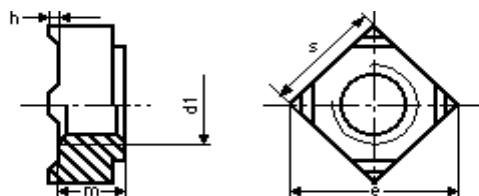

4 Weld Projections
Material (max. C=0.25%)
Thread Tolerance 6G

DIN 928																			
Thread Size d1	4		5		6		(7)		8		10		12		(14)		(16)		
Coarse Pitch	0.7		0.8		1		1		1.25		1.5		1.75		2		2		
Fine Pitch									1		1.25		1.5		1.5		1.5		
Extra Fine Pitch											1		1.25						
	min.	max.	min.	max.	min.	max.	min.	max.	min.	max.	min.	max.	min.	max.	min.	max.	min.	max.	
WAF s	6.64	7.00	8.64	9.00	9.65	10.00	10.57	11.00	13.57	14.00	16.57	17.00	18.48	19.00	21.48	22.00	23.48	24.00	
WAC e	9.00		12.00		13.00		14.00		18.00		22.00		25.00		28.00		32.00		
Weld Projection h	0.50	0.70	0.70	0.90	0.70	0.90	0.70	0.90	0.99	1.10	1.10	1.30	1.30	1.50	1.30	1.50	1.50	1.70	
Overall Height m	3.20	3.50	3.90	4.20	4.70	5.00	5.14	5.50	6.14	6.50	7.64	8.00	9.14	9.50	10.57	11.00	12.53	13.00	
Plate Thickness	0.75	3.00	0.88	3.50	0.88	4.00	0.88	4.00	1.00	4.50	1.25	5.00	1.50	5.00	2.00	6.00	2.00	6.00	
The proof loads as listed apply to the assessment of the mechanical properties of the weld nuts.																			
Proof Load (N)	6800		11000		15500		22300		28300		44800		65300		89700		123000		

3.13 - WELD NUTS

HEX WELD NUTS ▪ DIN 929

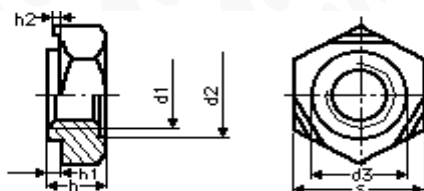

3 Weld Projections
Material (max. C=0.25%)
Thread Tolerance 6G

DIN 929																				
Thread Size	3		4		5		6		(7)		8		10		12		(14)		16	
Coarse Pitch	0.5		0.7		0.8		1		1		1.25		1.5		1.75		2		2	
Fine Pitch											1		1.25		1.5		1.5		1.5	
Extra Fine Pitch													1		1.25					
	min.	max.	min.	max.	min.	max.	min.	max.	min.	max.	min.	max.	min.	max.	min.	max.	min.	max.	min.	max.
WAF s	7.28	7.50	8.78	9.00	9.78	10.00	10.73	11.00	11.73	12.00	13.73	14.00	16.73	17.00	18.67	19.00	21.67	22.00	23.67	24.00
WAC e	8.15		9.83		10.95		12.02		13.14		15.38		18.74		20.91		24.27		26.51	
Weld Projection h	0.50	0.70	0.50	0.70	0.70	0.90	0.70	0.90	0.70	0.90	0.99	1.10	1.10	1.30	1.30	1.50	1.30	1.50	1.50	1.70
Overall Height m	2.70	3.00	3.20	3.50	3.70	4.00	4.70	5.00	5.20	5.50	6.14	6.50	7.64	8.00	9.14	10.00	10.57	11.00	12.53	13.00
Plate Thickness	0.63	2.50	0.75	3.00	0.88	3.50	0.88	4.00	0.88	4.00	1.00	4.50	1.25	5.00	1.50	5.00	2.00	6.00	2.00	6.00
The proof loads as listed apply to the assessment of the mechanical properties of the weld nuts.																				
Proof Load (N)	6800		6800		11000		15500		22300		28300		44800		65300		89700		123000	

FOR MORE DETAILED INFORMATION, PLEASE REFER TO COMPLETE DIN STANDARD, WHICH IS THE GOVERNING STANDARD

DIN 928 (1983) / DIN 929 (1983) - LF6 10/01/2016 REVISED

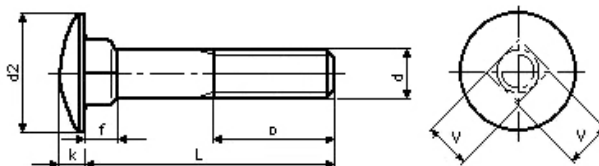

4.1 - CARRIAGE BOLTS

Thread Size d1	DIN 603	M5	M6	M8	M10	M12	M16	M20
Thread Pitch		0.8	1	1.25	1.5	1.75	2	2.5
Thread Length b1	For Lengths ≤125mm	16	18	22	26	30	38	46
	For Lengths >125mm≤200mm	22	24	28	32	36	44	52
	For Lengths >200 mm		37	41	45	49	57	65
Head Dia. d2	min.	12.45	15.45	19.35	23.35	29.35	37.20	45.20
	max.	13.55	16.55	20.65	24.65	30.65	38.80	46.80
Head Height k	min.	2.70	3.12	4.12	4.62	6.05	8.05	9.95
	max.	3.30	3.88	4.88	5.38	6.95	8.95	11.05
Square Depth f	min.	2.90	3.40	4.40	5.40	7.25	11.10	14.10
	max.	4.10	4.60	5.60	6.60	8.75	12.90	15.90
Square AF v	min.	4.52	5.52	7.42	9.42	11.30	15.30	19.16
	max.	5.48	6.48	8.58	10.58	12.70	16.70	20.84

Thread Size d1	ISO 8677 (Large Head)	M5	M6	M8	M10	M12	M16	M20
Thread Pitch		0.8	1	1.25	1.5	1.75	2	2.5
Thread Length b1	For Lengths ≤125mm	16	18	22	26	30	38	46
	For Lengths >125mm≤200mm	22	24	28	32	36	44	52
	For Lengths >200 mm		37	41	45	49	57	65
Head Dia. d2	min.	11.90	14.90	18.70	22.70	28.70	36.40	44.40
	max. = nom.	13.00	16.00	20.00	24.00	30.00	38.00	46.00
Head Height k	min.	2.50	3.00	4.00	5.00	6.00	8.00	10.00
	max.	3.10	3.60	4.80	5.80	6.80	8.90	10.90
Square Depth f	min.	2.90	3.40	4.40	5.40	7.20	11.10	14.10
	max.	4.10	4.60	5.60	6.60	8.80	12.90	15.90
Square AF v	min.	4.52	5.52	7.42	9.42	11.30	15.30	19.16
	max.	5.48	6.48	8.58	10.58	12.70	16.70	20.84

Thread Size d1	ISO 8678 & ASME B18.5.2.1M Small Head/Short Neck	M6	M8	M10	M12	(M14) ASME Only	M16	M20
Thread Pitch		1	1.25	1.5	1.75	2	2	2.5
Thread Length b1	For Lengths ≤125mm	18	22	26	30	34	38	46
	For Lengths >125mm≤200mm	24	28	32	36	40	44	52
	For Lengths >200 mm	37	41	45	49	53	57	65
Head Dia. d2	min.	No Head Diameter minimum specified in ISO 8678 and or ASME B18.5.2.1M						
	max.	14.20	18.00	22.30	26.60	30.50	35.00	43.00
Head Height k	min.	3.00	4.00	5.00	6.00	7.00	8.00	10.00
	max.	3.60	4.80	5.80	6.80	7.90	8.90	10.90
Square Depth f (Short Neck)	min.	2.40	2.40	3.20	3.20	3.20	4.20	4.20
	max.	3.00	3.00	4.00	4.00	4.00	5.00	5.00
Square AF v	min.	5.88	7.85	9.85	11.82	13.82	15.82	19.79
	max.	6.48	8.58	10.58	12.70	14.70	16.70	20.84

FOR MORE DETAILED INFORMATION, PLEASE REFER TO COMPLETE DIN, ISO OR ASME STANDARD, WHICH ARE THE GOVERNING STANDARDS

DIN 603 (1981) / ISO 8677 (1996) / ISO 8678 (1988) / ASME B 18.5.2.4M (1996) - LFG 10/01/10 REVISED

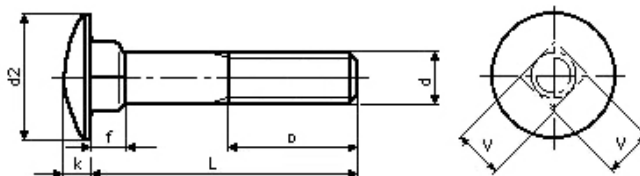

Nominal Length	Length Tolerance By Standard										
	DIN 603		ISO 8677		ISO 8678		ASME B18.5.2.1M				
	min.	max.		min.	max.	min.	max.		min.	max.	
12						11.10	12.90		11.10	12.90	
(14)						13.10	14.90				
16	15.10	16.90				15.10	16.90		15.10	16.90	
20	18.95	21.05		19.0	21.0	18.95	21.05		18.95	21.05	
25	23.95	26.05		24.0	26.0	23.95	26.05		23.95	26.05	
30	28.95	31.05		29.0	31.0	28.95	31.05		28.95	31.05	
35	33.75	36.25		33.7	36.3	33.75	36.25		33.75	36.25	
40	38.75	41.25		38.7	41.3	38.75	41.25		38.75	41.25	
45	43.75	46.25		43.7	46.3	43.75	46.25		43.75	46.25	
50	48.75	51.25		48.7	51.3	48.75	51.25		48.75	51.25	
(55)	53.50	56.50		53.5	56.5	53.50	56.50		53.50	56.50	
60	58.50	61.50		58.5	61.5	58.50	61.50		58.50	61.50	
(65)	63.50	66.50		63.5	66.5	63.50	66.50		63.50	66.50	
70	68.50	71.50		68.5	71.5	68.50	71.50		68.50	71.50	
(75)	73.50	76.50		73.5	76.5						
80	78.50	81.50		78.5	81.5	78.50	81.50		78.50	81.50	
90	88.25	91.75		88.3	91.7	88.25	91.75		88.25	91.75	
100	98.25	101.75		98.3	101.7	98.25	101.75		98.25	101.75	
110	108.25	111.75		108.3	111.7	108.25	111.75		108.25	111.75	
120	118.25	121.75		118.3	121.7	118.25	121.75		118.25	121.75	
130	128.00	132.00		128.0	132.0	128.00	132.00		128.00	132.00	
140	138.00	142.00		138.0	142.0	138.00	142.00		138.00	142.00	
150	148.00	152.00		148.0	152.0	148.00	152.00		148.00	152.00	
160	156.00	164.00		156.0	164.0	158.00	162.00		158.00	162.00	
180	176.00	184.00		176.0	184.0	177.70	182.30		177.70	182.30	
200	195.40	204.60		195.4	204.6	197.70	202.30		197.70	202.30	

Mechanical Properties	Diameters & Lengths With () are not recommended for new design.					
	3.6	4.6	8.8 ≤ 16mm	8.8 > 16mm	10.9	A2 Stainless
Material	3.6	4.6	8.8 ≤ 16mm	8.8 > 16mm	10.9	A2 Stainless
Finish	Plain or Plated					Plain
Tensile Strength	47850 psi	58000 psi	116000 psi	120350 psi	150800 psi	72500-116000 psi
Yield Strength	28710	34800 psi	92800 psi	95700 psi	136300 psi	30450-87000 psi
Hardness	52-99.5 HRB		22-32 HRC	23-34 HRC	32-39 HRC	NA
Thread Tolerance	Plain 6g			Plated 6h		6g

FOR MORE DETAILED INFORMATION, PLEASE REFER TO COMPLETE DIN, ISO OR ASME STANDARD, WHICH ARE THE GOVERNING STANDARDS

DIN 603 (1981) / ISO 8677 (1990) / ISO 8678 / ASME B 18.5.2.1M (1996) - LFG 10/01/10 REVISED

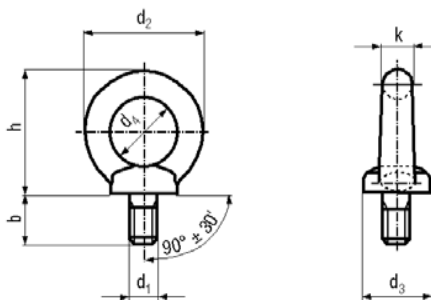

Standard	Thread Size d1											
DIN 580	(M6)	M8	M10	M12	(M14)	M16	M20	(M22)	M24	(M27)	M30	(M33)
Thread Pitch	1	1.25	1.5	1.75	2	2	2.5	2.5	3	3	3.5	3.5
Fine Pitch				1.5		1.5	2		2		2	
Ring OD d2	36	36	45	54	63	63	72	90	90	108	108	126
Ring ID d4	20	20	25	30	35	35	40	50	50	60	60	70
Ring Height to Include shoulder h	36	36	45	53	62	62	71	90	90	109	109	128
Ring Width k	8	8	10	12	14	14	16	20	20	24	24	28
Shoulder Diameter d3	20	20	25	30	35	35	40	50	50	65	65	75
Thread Length b	13.0	13.0	17.0	20.5	27.0	27.0	30.0	36.0	36.0	45.0	45.0	54.0
Bolts Must Be Stamped C 15	Maximum Permissible Load In Pounds With (1) One Or (2) Bolts Firmly Tightened											
With (1) One Bolt	154	308	506	748	1078	1540	2640	3300	3960	5500	7920	9460
With (2) Two Bolts @ 45°	110	209	374	528	748	1100	1826	2310	2794	3630	5720	7040

Standard	Thread Size d1										
DIN 580	M36	(M39)	M42	(M45)	M48	(M52)	M56	M64	M72	M80	M100
Thread Pitch	4	4	4.5	4.5	5	5	5.5	6	6	6	6
Fine Pitch	3		3		3		4	4	4	4	4
Ring OD d2	126	126	144	166	166	184	184	206	260	296	330
Ring ID d4	70	70	80	90	90	100	100	110	140	160	180
Ring Height to Include shoulder h	128	128	147	168	168	187	187	208	260	298	330
Ring Width k	28	28	32	38	38	42	42	48	60	68	75
Shoulder Diameter d3	75	75	85	100	100	110	110	120	150	170	190
Thread Length b	54	54	63	68	68	78	78	90	100	112	130
Bolts Must Be Stamped C 15	Maximum Permissible Load In Pounds With (1) One Or (2) Bolts Firmly Tightened										
With (1) One Bolt	11220	13420	15400	17600	18920	21780	25300	35200	46200	61600	83600
With (2) Two Bolts @ 45°	8140	9460	11000	12100	13420	16060	18260	24200	33000	44000	59400

M6, M14, M22, M27, M33, M39, M45 & M52 Are Not Included In DIN 580, And Should Not Be Considered For New Designs. Also The Dimensions Could Vary From What Is Shown Above.

Fine Pitch DIN 580 Eye Bolts Only Available Upon Special Request.

If DIN 580 Eye Bolts Are Not Stamped C 15 Refer To Complete DIN Standard For Correct Load Information.

DIN 580 Does Not Reference Any Material Other Than C 15 Steel (Plain Or Zinc Plated), But Some Sizes Are Available In A2 And Or A4 Stainless Steel.

FOR MORE DETAILED INFORMATION, PLEASE REFER TO COMPLETE DIN STANDARD, WHICH IS THE GOVERNING STANDARD

DIN 580 (1972)- LFG 10/01/2016 REVISED

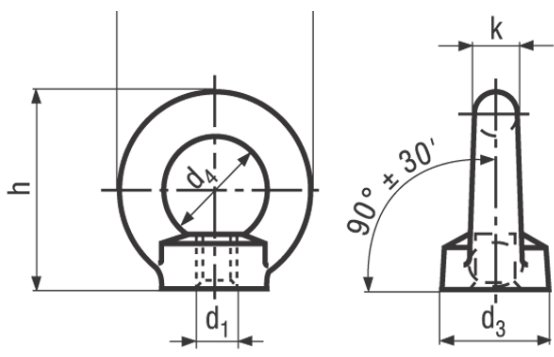

Standard	Thread Size d1										
DIN 582	(M6)	M8	M10	M12	(M14)	M16	M20	(M22)	M24	(M27)	M30
Thread Pitch	1	1.25	1.5	1.75	2	2	2.5	2.5	3	3	3.5
Fine Pitch							2		2		2
Ring OD d2	36	36	45	54	63	63	72	81	90	90	108
Ring ID d4	20	20	25	30	35	35	40	45	50	50	60
Ring Height to Include shoulder h	36	36	45	53	62	62	71	90	90	90	109
Ring Width k	7	8	10	12	14	14	16	18	20	20	24
Shoulder Diameter d3	20	20	25	30	35	35	40	45	50	50	65
Internal Thread Length	8.5	8.5	10.0	11.0	13.0	13.0	16.0	18.0	20.0	20.0	25.0
Nuts Must Be Stamped C 15	Maximum Permissible Load In Pounds With (1) One Or (2) Nuts Firmly Tightened										
With (1) One Nut	154	308	506	748	1078	1540	2640	3300	3960	5500	7920
With (2) Two Nuts @ 45°	110	209	374	528	748	1100	1826	2310	2794	3630	5720

Standard	Thread Size d1										
DIN 582	(M33)	M36	(M39)	M42	(M45)	M48	M56	M64	M72	M80	M100
Thread Pitch	3.5	4	4	4.5	4.5	5	5.5	6	6	6	6
Fine Pitch		3		3		3	4	4	4	4	4
Ring OD d2	108	126	126	144	144	166	184	206	260	296	330
Ring ID d4	60	70	70	80	80	90	100	110	140	160	180
Ring Height to Include shoulder h	109	128	128	147	147	168	187	208	260	298	330
Ring Width k	24	28	28	32	32	38	42	48	60	68	75
Shoulder Diameter d3	65	75	75	85	85	100	110	120	150	170	190
Internal Thread Length	25	30	30	35	35	40	45	50	60	70	80
Nuts Must Be Stamped C 15	Maximum Permissible Load In Pounds With (1) One Or (2) Nuts Firmly Tightened										
With (1) One Nut	9460	11220	13420	15400	17600	18920	25300	35200	46200	61600	83600
With (2) Two Nuts @ 45°	7040	8140	9460	11000	12100	13420	18260	24200	33000	44000	59400

M6, M14, M22, M27, M33, M39, & M45 Are Not Included In DIN 582, And Should Not Be Considered For New Designs. Also The Dimensions Could Vary From What Is Shown Above.

Fine Pitch DIN 582 Eye Nuts Only Available Upon Special Request.

If DIN 582 Eye Nuts Are Not Stamped C 15 Refer To Complete DIN Standard For Correct Load Information.

DIN 582 Does Not Reference Any Material Other Than C 15 Steel (Plain Or Zinc Plated) - Some Sizes Are Available In A2 And Or A4 Stainless Steel

FOR MORE DETAILED INFORMATION, PLEASE REFER TO COMPLETE DIN STANDARD, WHICH IS THE GOVERNING STANDARD

DIN 582 (1971)- LFG 10/01/2016 REVISED



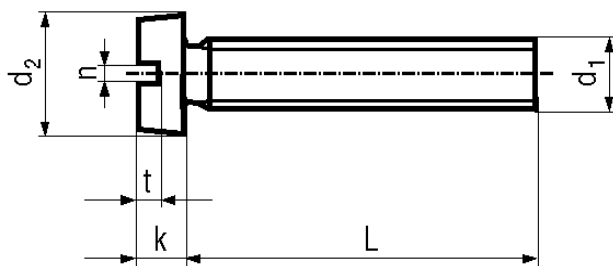

Head Diameter (d2)	Size d1	M1.6		M2		M2.5		(M2.6)		M3		(M3.5)		M4		M5		M6		M8		M10	
Standard		min.	max.	min.	max.	min.	max.	min.	max.	min.	max.	min.	max.	min.	max.	min.	max.	min.	max.	min.	max.	min.	max.
DIN 84 (1990)		2.86	3.00	3.62	3.80	4.32	4.50	4.82	5.00	5.32	5.50	5.82	6.00	6.78	7.00	8.28	8.50	9.78	10.00	12.73	13.00	15.73	16.00
ISO 1207 (1992)		2.86	3.00	3.62	3.80	4.32	4.50			5.32	5.50	5.82	6.00	6.78	7.00	8.28	8.50	9.78	10.00	12.73	13.00	15.73	16.00

Head Height (k)	Size d1	M1.6		M2		M2.5		(M2.6)		M3		(M3.5)		M4		M5		M6		M8		M10	
Standard		min.	max.	min.	max.	min.	max.	min.	max.	min.	max.	min.	max.	min.	max.	min.	max.	min.	max.	min.	max.	min.	max.
DIN 84 (1990)		0.86	1.00	1.16	1.30	1.46	1.60	1.56	1.70	1.86	2.00	2.26	2.40	2.46	2.60	3.12	3.30	3.60	3.90	4.70	5.00	5.70	6.00
ISO 1207 (1992)		0.96	1.10	1.26	1.40	1.66	1.80			1.86	2.00	2.26	2.40	2.46	2.60	3.12	3.30	3.60	3.90	4.70	5.00	5.70	6.00

Slot Width (n)	Size d1	M1.6		M2		M2.5		(M2.6)		M3		(M3.5)		M4		M5		M6		M8		M10	
Standard		min.	max.	min.	max.	min.	max.	min.	max.	min.	max.	min.	max.	min.	max.	min.	max.	min.	max.	min.	max.	min.	max.
DIN 84 (1990)		0.46	0.60	0.56	0.70	0.66	0.80	0.66	0.80	0.86	1.00	1.06	1.20	1.26	1.51	1.26	1.51	1.66	1.91	2.06	2.31	2.56	2.81
ISO 1207 (1992)		0.46	0.60	0.56	0.70	0.66	0.80			0.86	1.00	1.06	1.20	1.26	1.51	1.26	1.51	1.66	1.91	2.06	2.31	2.56	2.81

Slot Depth (t)	Size d1	M1.6		M2		M2.5		(M2.6)		M3		(M3.5)		M4		M5		M6		M8		M10	
Standard		min.	max.	min.	max.	min.	max.	min.	max.	min.	max.	min.	max.	min.	max.	min.	max.	min.	max.	min.	max.	min.	max.
DIN 84 (1990)		0.45	0.60	0.60	0.80	0.70	0.90	0.80	1.00	1.15	1.10	1.40	1.20	1.50	1.50	1.80	1.80	2.20	2.10	2.60	2.40	3.00	
ISO 1207 (1992)		0.45		0.60		0.70				0.85		1.00		1.10		1.30		1.60		2.00		2.40	

Length Tolerance	DIN 84/ISO 1207	
Nominal Length	min.	max.
2	1.80	2.20
2.5	2.30	2.70
3	2.80	3.20
4	3.76	4.24
5	4.76	5.24
6	5.76	6.24
8	7.71	8.29
10	9.71	10.29
12	11.65	12.35
(14)	13.65	14.35
16	15.65	16.35
(18)	17.65	18.35
20	19.58	20.42
(22)	21.58	22.42
25	24.58	25.42
(28)	27.58	28.42
30	29.58	30.42
35	34.50	35.50
40	39.50	40.50
45	44.50	45.50
50	49.50	50.50
(55)	54.05	55.95
60	59.05	60.95
(65)	64.05	65.95
70	69.05	70.95
(75)	74.05	75.95
80	79.05	80.95
90	88.90	91.10

Diameters & Lengths With () are not recommended for new design.

Thread Pitch	Thread Tolerance Plain 6g	
Dia.	Thread Tolerance Plated 6h	
M1.6	Thread Tolerance Stainless 6g	
M2		
M2.5	Material	4.8 A2 - A4
(M2.6)	Tensile Strength	60900 72500-101500
M3		
(M3.5)	Yield Strength	49300 30450-65250
M4		
M5	Hardness	HRB NA
M6		
(M8)		
(M10)	Property Class	Steel 4.8 Stainless Steel A2 - A4
	Finish	Plain /Plated Plain

For Machine Screws, The Letter A After The DIN Number Indicates Full Thread. Unless Requested, All Machine Screws Are Supplied As Full Thread, Therefore We Omit The A.

FOR MORE DETAILED INFORMATION, PLEASE REFER TO COMPLETE DIN OR ISO STANDARD, WHICH ARE THE GOVERNING STANDARDS

DIN 84 (1990) / ISO 1207 (1992) - LFG 10/01/10 REVISED

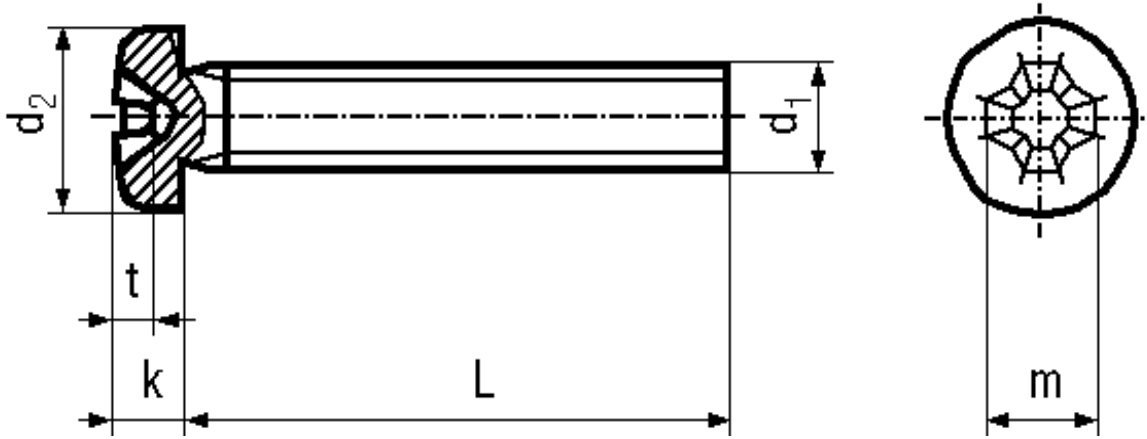

Head Diameter (d2)	Size d1	(M1.6)		(M2)		M2.5		M3		(M3.5)		M4		M5		M6		M8	
Standard		min.	max.	min.	max.	min.	max.	min.	max.	min.	max.	min.	max.	min.	max.	min.	max.	min.	max.
ISO 7048 (1998)						4.32	4.50	5.32	5.50	5.82	6.00	6.78	7.00	8.28	8.50	9.78	10.00	12.73	13.00
SN 213307		2.86	3.00	3.62	3.80	4.32	4.50	5.32	5.50	5.82	6.00	6.78	7.00	8.28	8.50	9.78	10.00	12.73	13.00

Head Height (k)	Size d1	(M1.6)		(M2)		M2.5		M3		(M3.5)		M4		M5		M6		M8	
Standard		min.	max.	min.	max.	min.	max.	min.	max.	min.	max.	min.	max.	min.	max.	min.	max.	min.	max.
ISO 7048 (1998)						1.66	1.80	1.86	2.00	2.26	2.40	2.46	2.60	3.12	3.30	3.60	3.90	4.70	5.00
SN 213307		0.96	1.10	1.26	1.40	1.66	1.80	1.86	2.00	2.26	2.40	2.46	2.60	3.12	3.30	3.60	3.90	4.70	5.00

Cross Recess Size (m)	Size d1	(M1.6)		(M2)		M2.5		M3		(M3.5)		M4		M5		M6		M8	
Standard																			
ISO 7048 (1998)						1				2								3	
SN 213307		0			1					2								3	

Cross Recess Penetration (t)	Size d1	(M1.6)		(M2)		M2.5		M3		(M3.5)		M4		M5		M6		M8	
Standard		min.	max.	min.	max.	min.	max.	min.	max.	min.	max.	min.	max.	min.	max.	min.	max.	min.	max.
ISO 7048 (1998)						1.20	1.62	0.86	1.43	1.15	1.73	1.45	2.03	2.14	2.73	2.25	2.86	3.73	4.36
SN 213307		0.70	0.90	0.90	1.10	1.20	1.62	0.86	1.43	1.15	1.73	1.45	2.03	2.14	2.73	2.25	2.86	3.73	4.36

Length Tolerance	ISO 7048 / SN 213307	
	min.	max.
Nominal Length		
2	1.80	2.20
(2.5)	2.30	2.70
3	2.80	3.20
4	3.76	4.24
5	4.76	5.24
6	5.76	6.24
8	7.71	8.29
10	9.71	10.29
12	11.65	12.35
(14)	13.65	14.35
16	15.65	16.35
(18)	17.65	18.35
20	19.58	20.42
(22)	21.58	22.42
25	24.58	25.42
(28)	27.58	28.42
30	29.58	30.42
35	34.50	35.50
40	39.50	40.50
45	44.50	45.50
50	49.50	50.50
(55)	54.05	55.95
60	59.05	60.95
(65)	64.05	65.95
70	69.05	70.95
(75)	74.05	75.95
80	79.05	80.95
90	88.90	91.10

Diameters & Lengths With () are not recommended for new design.

Thread Pitch		Thread Tolerance Plain 6g	
Di.	Pitch	Thread Tolerance Plated 6h	
M1.6	0.35	Thread Tolerance Stainless 6g	
M2	0.4	Material	4.8 A2 - A4
M2.5	0.45	Tensile Strength	60900 72500-101500
M3	0.5		
(M3.5)	0.6	Yield Strength	49300 30450-65250
M4	0.7		
M5	0.8	Hardness	HRB NA
M6	1		
M8	1.25	Steel	Stainless Steel
Property Class		4.8 A2 - A4	
Finish		Plain /Plated Plain	

M1.6 & M2 are not listed in ISO 7048

FOR MORE DETAILED INFORMATION, PLEASE REFER TO COMPLETE ISO OR SN STANDARD, WHICH ARE THE GOVERNING STANDARDS

ISO 7048 (1998) / SN 213307 - LFG 10/01/10 REVISED

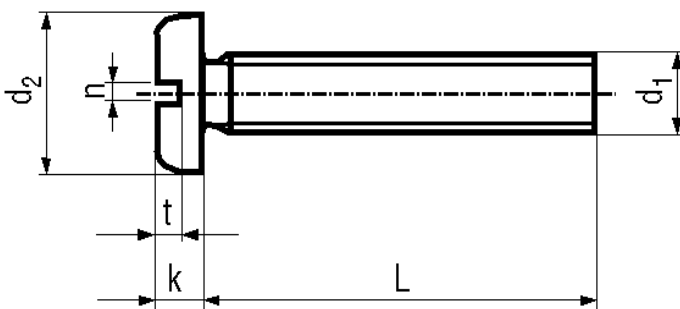

Head Diameter (d2)	Size d1	M1.6		M2		M2.5		M3		(M3.5)		M4		M5		M6		M8		M10	
		min.	max.	min.	max.	min.	max.	min.	max.	min.	max.	min.	max.	min.	max.	min.	max.	min.	max.	min.	max.
Standard																					
DIN 85 (1990)																					
ISO 1580 (1994)		2.90	3.20	3.70	4.00	4.70	5.00	5.60	6.64	7.00	7.64	8.00	9.64	10.00	11.57	12.00	15.57	16.00	19.48	20.00	
JIS B 1101 (1977)		2.60	3.00	3.10	3.50	4.10	4.50	5.00	5.50	5.50	6.00	6.50	7.00	8.40	9.00	9.80	10.50	13.20	14.00		
ANSI B 18.16.7 M (1985)				3.70	4.00	4.70	5.00	5.30	5.60	6.60	7.00	7.60	8.00	9.10	9.50	11.50	12.00	15.50	16.00	19.40	20.00

Head Height (k)	Size d1	M1.6		M2		M2.5		M3		(M3.5)		M4		M5		M6		M8		M10	
		min.	max.	min.	max.	min.	max.	min.	max.	min.	max.	min.	max.	min.	max.	min.	max.	min.	max.	min.	max.
Standard																					
DIN 85 (1990)								1.66	1.80	1.96	2.10	2.26	2.40	2.86	3.00	3.30	3.60	4.50	4.80	5.70	6.00
ISO 1580 (1994)		0.86	1.00	1.16	1.30	1.36	1.50	1.66	1.80	1.96	2.10	2.26	2.40	2.86	3.00	3.30	3.60	4.50	4.80	5.70	6.00
JIS B 1101 (1977)		0.90	1.10	1.20	1.40	1.60	1.80	1.85	2.15	2.15	2.45	2.45	2.75	3.15	3.45	3.70	4.10	5.00	5.40		
ANSI B 18.16.7 M (1985)				1.10	1.30	1.30	1.50	1.60	1.80	1.90	2.10	2.20	2.40	2.70	3.00	3.30	3.60	4.50	4.80	5.70	6.00

Slot Width (n)	Size d1	M1.6		M2		M2.5		M3		(M3.5)		M4		M5		M6		M8		M10	
		min.	max.	min.	max.	min.	max.	min.	max.	min.	max.	min.	max.	min.	max.	min.	max.	min.	max.	min.	max.
Standard																					
DIN 85 (1990)								0.86	1.00	1.06	1.20	1.26	1.51	1.26	1.51	1.66	1.91	2.06	2.31	2.56	2.81
ISO 1580 (1994)		0.46	0.60	0.56	0.70	0.66	0.80	0.86	1.00	1.06	1.20	1.26	1.51	1.26	1.51	1.66	1.91	2.06	2.31	2.56	2.81
JIS B 1101 (1977)		0.40	0.55	0.60	0.75	0.80	0.95	0.80	0.95	1.00	1.15	1.00	1.15	1.20	1.40	1.20	1.40	1.60	1.80		
ANSI B 18.16.7 M (1985)				0.50	0.70	0.60	0.80	0.80	1.00	1.00	1.20	1.20	1.50	1.20	1.50	1.60	1.90	2.00	2.30	2.50	2.80

Slot Depth (t)	Size d1	M1.6		M2		M2.5		M3		(M3.5)		M4		M5		M6		M8		M10	
		min.	max.	min.	max.	min.	max.	min.	max.	min.	max.	min.	max.	min.	max.	min.	max.	min.	max.	min.	max.
Standard																					
DIN 85 (1990)								0.70		0.80		1.00		1.20		1.40		1.90		2.40	
ISO 1580 (1994)		0.35		0.50		0.60		0.70		0.80		1.00		1.20		1.40		1.90		2.40	
JIS B 1101 (1977)		0.45	0.65	0.60	0.80	0.75	1.05	0.95	1.25	1.05	1.45	1.20	1.60	1.50	2.10	1.80	2.40	2.30	3.30		
ANSI B 18.16.7 M (1985)				0.50		0.60		0.70		0.80		1.00		1.20		1.40		1.90		2.40	

Length Tolerance		DIN 85/ISO 1580	
Nominal Length	min.	max.	
2			
(2.5)			
3	2.80	3.20	
4	3.76	4.24	
5	4.76	5.24	
6	5.76	6.24	
8	7.71	8.29	
10	9.71	10.29	
12	11.65	12.35	
(14)	13.65	14.35	
16	15.65	16.35	
(18)	17.65	18.35	
20	19.58	20.42	
(22)	21.58	22.42	
25	24.58	25.42	
(28)	27.58	28.42	
30	29.58	30.42	
35	34.50	35.50	
40	39.50	40.50	
45	44.50	45.50	
50	49.50	50.50	
(55)	54.05	55.95	
60	59.05	60.95	
(65)	64.05	65.95	
70	69.05	70.95	
(75)	74.05	75.95	
80	79.05	80.95	
90	88.90	91.10	

JIS B 111					
Over M2.6 To M4.5		Over M4.5 To M8		M10 & Above	
min.	max.	min.	max.	min.	max.
				1.7	2.0
				2.7	3.0
				3.7	4.0
4.4	5.0	4.2	5.0	4.6	5.0
5.4	6.0	5.2	6.0	5.6	6.0
7.4	8.0	7.2	8.0	7.6	8.0
9.4	10.0	9.2	10.0	9.6	10.0
11.4	12.0	11.0	12.0	11.4	12.0
15.4	16.0	15.0	16.0	15.4	16.0
19.4	20.0	19.0	20.0	19.4	20.0
24.2	25.0	24.0	25.0	24.2	25.0
29.2	30.0	29.0	30.0	29.2	30.0
34.2	35.0	34.0	35.0	34.2	35.0
39.2	40.0	39.0	40.0	39.2	40.0
44.0	45.0	44.0	45.0		
49.0	50.0	49.0	50.0		
54.0	55.0	54.0	55.0		
		59.0	60.0		
		69.0	70.0		
		79.0	80.0		
		89.0	90.0		

ANSI B 18.16.7 M	
min.	max.
2.3	2.7
2.8	3.2
3.7	4.3
4.7	5.3
5.7	6.3
7.7	8.3
9.7	10.3
12.6	13.4
15.6	16.4
19.5	20.5
24.5	25.5
29.5	30.5
34.5	35.5
39.5	40.5
44.5	45.5
49.5	50.5
54.0	56.0
59.0	61.0
64.0	66.0
69.0	71.0
79.0	81.0
89.0	91.0

Diameters & Lengths With () are not recommended for new design.

Thread Pitch		Thread Tolerance Plain 6g	
Dia.	Pitch	Thread Tolerance Plated 6h	
M1.6	0.35	Thread Tolerance Stainless 6g	
M2	0.4		
M2.5	0.45	Material	4.8 A2 - A4
(M2.6)	0.45	Tensile Strength	60900 72500-101500
M3	0.5	Yield Strength	49300 30450-65250
(M3.5)	0.6	Hardness	HRB 71-99.5 NA
M4	0.7		
M5	0.8		
M6	1		
(M8)	1.25	Steel	Stainless Steel
(M10)	1.5	Property Class	4.8 A2 - A4
		Finish	Plain /Plated Plain

For Machine Screws, The Letter A After The DIN Number Indicates Full Thread. Unless Requested, All Machine Screws Are Supplied As Full Thread, Therefore We Omit The A.
 Refer To ISO 1580 For M2, M2.5, and M10, As these Three Diameters Are Not Available In DIN 85 A
 M2.6 Is Not Available In DIN 85 A Or ISO 1580. Use M2.5 ISO 1580 For Dimensional Information.
 Neither DIN, ISO, Or ANSI Specify A maximum Slot Depth.

FOR MORE DETAILED INFORMATION, PLEASE REFER TO COMPLETE DIN OR ISO STANDARD, WHICH ARE THE GOVERNING STANDARDS

DIN 85 (1990) / ISO 1580 (1994) / JIS B1101 (1977) / ANSI B 18.6.7 M (1985) - LFG 10/01/2016

PAN HEAD PHILLIPS MACHINE SCREWS - DIN 7985 / ISO 7045 / JIS B 1111 / ANSI B 18.6.7 M

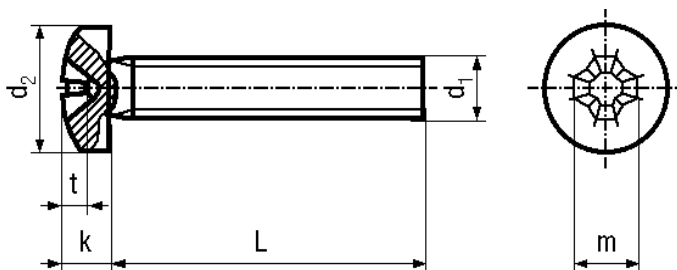

Head Diameter (d2)	Size d1	M1.6		M2		M2.5		M3		(M3.5)		M4		M5		M6		M8		M10	
Standard		min.	max.	min.	max.	min.	max.	min.	max.	min.	max.	min.	max.	min.	max.	min.	max.	min.	max.	min.	max.
DIN 7985 (1990)		2.90	3.20	3.70	4.00	4.70	5.00	5.70	6.00	6.64	7.00	7.64	8.00	9.64	10.00	11.57	12.00	15.57	16.00	19.48	20.00
ISO 7045 (1994)		2.90	3.20	3.70	4.00	4.70	5.00	5.30	5.60	6.64	7.00	7.64	8.00	9.14	9.50	11.57	12.00	15.57	16.00	19.48	20.00
JIS B 1111 (1977)				3.10	3.50	4.10	4.50	5.00	5.50	5.50	6.00	6.50	7.00	8.40	9.00	9.80	10.50	13.20	14.00		
ANSI B 18.16.7 M (1985)				3.70	4.00	4.70	5.00	5.30	5.60	6.60	7.00	7.60	8.00	9.10	9.50	11.50	12.00	15.50	16.00	19.40	20.00

Head Height (k)	Size d1	M1.6		M2		M2.5		M3		(M3.5)		M4		M5		M6		M8		M10	
Standard		min.	max.	min.	max.	min.	max.	min.	max.	min.	max.	min.	max.	min.	max.	min.	max.	min.	max.	min.	max.
DIN 7985 (1990)		1.18	1.42	1.48	1.72	1.88	2.12	2.28	2.52	2.58	2.82	2.95	3.25	3.65	3.95	4.45	4.75	5.85	6.15	7.32	7.68
ISO 7045 (1994)		1.16	1.30	1.46	1.60	1.96	2.10	2.26	2.40	2.46	2.60	2.92	3.10	3.52	3.70	4.30	4.60	5.70	6.00	7.14	7.50
JIS B 1111 (1977)				1.20	1.40	1.60	1.80	1.85	2.15	2.15	2.45	2.45	2.75	3.15	3.45	3.70	4.10	5.00	5.40		
ANSI B 18.16.7 M (1985)				1.40	1.60	1.90	2.10	2.20	2.40	2.30	2.60	2.80	3.10	3.40	3.70	4.30	4.60	5.60	6.00	7.10	7.50

Cross Recess Size (m)	Size d1	M1.6	M2	M2.5	M3	(M3.5)	M4	M5	M6	M8	M10
Standard											
DIN 7985 (1990)		0		1			2		3		4
ISO 7045 (1994)		0		1			2		3		4
JIS B 1111 (1977)				1			2		3		4
ANSI B 18.16.7 M (1985)			0	1			2		3		4

Cross Recess Penetration (t)	Size d1	M1.6		M2		M2.5		M3		(M3.5)		M4		M5		M6		M8		M10	
Standard		min.	max.	min.	max.	min.	max.	min.	max.	min.	max.	min.	max.	min.	max.	min.	max.	min.	max.	min.	max.
DIN 7985 (1990)		0.72	1.02	1.10	1.40	1.30	1.60	1.70	2.00	1.74	2.24	2.04	2.54	2.77	3.27	3.03	3.53	4.18	4.68	5.38	5.88
ISO 7045 (1994)		0.70	0.95	0.90	1.20	1.15	1.55	1.40	1.80	1.40	1.90	1.90	2.40	2.40	2.90	3.10	3.60	4.00	4.60	5.20	5.80
JIS B 1111 (1977)				0.60	1.01	1.00	1.42	0.86	1.43	1.15	1.73	1.45	2.03	2.14	2.73	2.26	2.86	3.73	4.36		
ANSI B 18.16.7 M (1985)				0.95	1.20	1.15	1.55	1.40	1.80	1.40	1.90	1.90	2.40	2.40	2.90	3.10	3.60	4.00	4.60	5.20	5.80

Length Tolerance	DIN7985/ISO7045	
	min.	max.
Nominal Length		
2		
2.5		
3	2.80	3.20
4	3.76	4.24
5	4.76	5.24
6	5.76	6.24
8	7.71	8.29
10	9.71	10.29
12	11.65	12.35
(14)	13.65	14.35
16	15.65	16.35
(18)	17.65	18.35
20	19.58	20.42
(22)	21.58	22.42
25	24.58	25.42
(28)	27.58	28.42
30	29.58	30.42
35	34.50	35.50
40	39.50	40.50
45	44.50	45.50
50	49.50	50.50
(55)	54.05	55.95
60	59.05	60.95
(65)	64.05	65.95
70	69.05	70.95
(75)	74.05	75.95
80	79.05	80.95
90	88.90	91.10

JIS B 1111					
min.	max.	min.	max.	min.	max.
1.7	2.0				
2.7	3.0				
3.7	4.0				
4.6	5.0	4.4	5.0	4.2	5.0
5.6	6.0	5.4	6.0	5.2	6.0
7.6	8.0	7.4	8.0	7.2	8.0
9.6	10.0	9.4	10.0	9.2	10.0
11.4	12.0	11.4	12.0	11.0	12.0
15.4	16.0	15.4	16.0	15.0	16.0
19.4	20.0	19.4	20.0	19.0	20.0
24.2	25.0	24.2	25.0	24.0	25.0
29.2	30.0	29.2	30.0	29.0	30.0
34.2	35.0	34.2	35.0	34.0	35.0
39.2	40.0	39.2	40.0	39.0	40.0
		44.0	45.0	44.0	45.0
		49.0	50.0	49.0	50.0
		54.0	55.0	54.0	55.0
				59.0	60.0
				69.0	70.0
				79.0	80.0
				89.0	90.0

ANSI B 18.16.7 M	
min.	max.
2.3	2.7
2.8	3.2
3.7	4.3
4.7	5.3
5.7	6.3
7.7	8.3
9.7	10.3
12.7	13.3
15.7	16.3
19.5	20.5
24.5	25.5
29.5	30.5
34.5	35.5
39.5	40.5
44.5	45.5
49.5	50.5
54.0	56.0
59.0	61.0
64.0	66.0
69.0	71.0
79.0	81.0
89.0	91.0

Diameters & Lengths With () are not recommended for new design.

Thread Pitch		Thread Tolerance Plain 6g	
Di.	Pitch	Thread Tolerance Plated 6h	
M1.6	0.35	Thread Tolerance Stainless 6g	
M2	0.4		
M2.5	0.45	Material	4, 8 A2 - A4
(M2.6)	0.45	Tensile Strength	60900 72500-101500
M3	0.5	Yield Strength	49300 30450-65250
(M3.5)	0.6		
M4	0.7	Hardness	HRB NA
M5	0.8		
M6	1		
(M8)	1.25		
(M10)	1.5	Steel	Stainless Steel
Property Class		4, 8	A2 - A4
Finish		Plain /Plated	Plain

For Machine Screws, The Letter A After The DIN Number Indicates Full Thread. Unless Requested, All Machine Screws Are Supplied As Full Thread, Therefore We Omit The A.

FOR MORE DETAILED INFORMATION, PLEASE REFER TO COMPLETE DIN, ISO, JIS OR ANSI STANDARD, WHICH ARE THE GOVERNING STANDARDS

DIN 7985 (1990) / ISO 7045(1994) / JIS B1111 (1977) / ANSI B 18.16.7 M (1985) - LFG 10/01/2016 REVISED

5.5 - FLAT HEAD SLOTTED MACHINE SCREWS

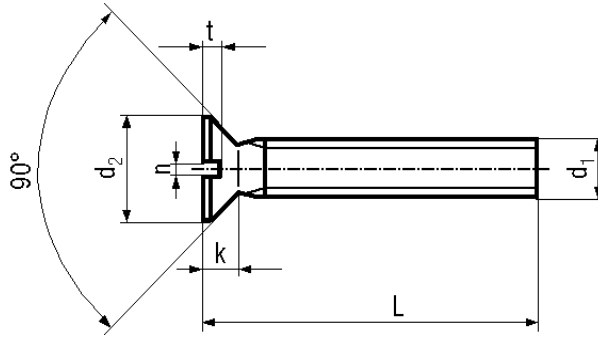

Head Diameter (d2)	Size d1	M1.6		M2		M2.5		M3		(M3.5)		M4		M5		M6		M8		M10	
Standard		min.	max.	min.	max.	min.	max.	min.	max.	min.	max.	min.	max.	min.	max.	min.	max.	min.	max.	min.	max.
DIN 963 (1990)		2.86	3.00	3.50	3.80	4.40	4.70	5.30	5.60	6.14	6.50	7.14	7.50	8.84	9.20	10.57	11.00	14.07	14.50	17.57	18.00
ISO 2009 (1994)		2.70	3.00	3.50	3.80	4.40	4.70	5.20	5.50	6.94	7.30	8.04	8.40	8.94	9.30	10.87	11.30	15.37	15.80	17.78	18.30
JIS B 1101 (1977)		2.80	3.20	3.60	4.00	4.60	5.00	5.50	6.00	6.50	7.00	7.50	8.00	9.40	10.00	11.30	12.00	15.20	16.00		
ANSI B 18.16.7 M (1985)				3.50		4.40		5.20		6.90		8.00		8.90		10.90		15.40		17.80	

Head Height (k)	Size d1	M1.6		M2		M2.5		M3		(M3.5)		M4		M5		M6		M8		M10	
Standard		min.	max.	min.	max.	min.	max.	min.	max.	min.	max.	min.	max.	min.	max.	min.	max.	min.	max.	min.	max.
DIN 963 (1990)			0.96		1.20		1.50		1.65		1.93		2.20		2.50		3.00		4.00		5.00
ISO 2009 (1994)			1.00		1.20		1.50		1.65		2.35		2.70		2.70		3.30		4.65		5.00
JIS B 1101 (1977)		0.85	0.95	1.00	1.20	1.25	1.45	1.45	1.75	1.70	2.00	2.00	2.30	2.50	2.80	3.00	3.40	4.00	4.40		
ANSI B 18.16.7 M (1985)					1.20		1.50		1.70		2.30		2.70		2.70		3.30		4.60		5.00

Slot Width (n)	Size d1	M1.6		M2		M2.5		M3		(M3.5)		M4		M5		M6		M8		M10	
Standard		min.	max.	min.	max.	min.	max.	min.	max.	min.	max.	min.	max.	min.	max.	min.	max.	min.	max.	min.	max.
DIN 963 (1990)		0.46	0.60	0.56	0.70	0.66	0.80	0.86	1.00	0.86	1.00	1.06	1.20	1.26	1.51	1.66	1.91	2.06	2.31	2.56	2.81
ISO 2009 (1994)		0.46	0.60	0.56	0.70	0.66	0.80	0.86	1.00	1.06	1.20	1.26	1.51	1.26	1.51	1.66	1.91	2.06	2.31	2.56	2.81
JIS B 1101 (1977)		0.40	0.55	0.60	0.75	0.80	0.95	0.80	0.95	1.00	1.15	1.00	1.15	1.20	1.40	1.20	1.40	1.60	1.80		
ANSI B 18.16.7 M (1985)				0.50	0.70	0.60	0.80	0.80	1.00	1.00	1.20	1.20	1.50	1.20	1.50	1.60	1.90	2.00	2.30	2.50	2.80

Slot Depth (t)	Size d1	M1.6		M2		M2.5		M3		(M3.5)		M4		M5		M6		M8		M10	
Standard		min.	max.	min.	max.	min.	max.	min.	max.	min.	max.	min.	max.	min.	max.	min.	max.	min.	max.	min.	max.
DIN 963 (1990)		0.32	0.45	0.40	0.60	0.50	0.70	0.60	0.85	0.70	1.00	0.80	1.10	1.00	1.30	1.20	1.60	1.60	2.10	2.00	2.60
ISO 2009 (1994)		0.32	0.50	0.40	0.60	0.50	0.75	0.60	0.85	0.90	1.20	1.00	1.30	1.10	1.40	1.20	1.60	1.80	2.30	2.00	2.60
JIS B 1101 (1977)		0.30	0.40	0.40	0.60	0.50	0.70	0.60	0.80	0.65	0.95	0.75	1.05	0.90	1.30	1.15	1.65	1.50	2.10		
ANSI B 18.16.7 M (1985)				0.40	0.60	0.50	0.70	0.60	0.90	0.90	1.20	1.00	1.30	1.10	1.40	1.20	1.60	1.80	2.30	2.00	2.60

Length Tolerance	DIN963/ISO2009	
	min.	max.
Nominal Length		
2		
2.5		
3	2.80	3.20
4	3.76	4.24
5	4.76	5.24
6	5.76	6.24
8	7.71	8.29
10	9.71	10.29
12	11.65	12.35
(14)	13.65	14.35
16	15.65	16.35
(18)	17.65	18.35
20	19.58	20.42
(22)	21.58	22.42
25	24.58	25.42
(28)	27.58	28.42
30	29.58	30.42
35	34.50	35.50
40	39.50	40.50
45	44.50	45.50
50	49.50	50.50
(55)	54.05	55.95
60	59.05	60.95
(65)	64.05	65.95
70	69.05	70.95
(75)	74.05	75.95
80	79.05	80.95
90	88.90	91.10

JIS B 1101					
min.	max.	min.	max.	min.	max.
1.7	2.0				
2.7	3.0				
3.7	4.0				
4.6	5.0	4.4	5.0	4.2	5.0
5.6	6.0	5.4	6.0	5.2	6.0
7.6	8.0	7.4	8.0	7.2	8.0
9.6	10.0	9.4	10.0	9.2	10.0
11.4	12.0	11.4	12.0	11.0	12.0
15.4	16.0	15.4	16.0	15.0	16.0
19.4	20.0	19.4	20.0	19.0	20.0
24.2	25.0	24.2	25.0	24.0	25.0
29.2	30.0	29.2	30.0	29.0	30.0
34.2	35.0	34.2	35.0	34.0	35.0
39.2	40.0	39.2	40.0	39.0	40.0
		44.0	45.0	44.0	45.0
		49.0	50.0	49.0	50.0
		54.0	55.0	54.0	55.0
				59.0	60.0
				69.0	70.0
				79.0	80.0
				89.0	90.0

ANSI B 18.16.7 M	
min.	max.
2.3	2.7
2.8	3.2
3.7	4.3
4.7	5.3
5.7	6.3
7.7	8.3
9.7	10.3
11.7	12.3
15.7	16.3
19.5	20.5
24.5	25.5
29.5	30.5
34.5	35.5
39.5	40.5
44.5	45.5
49.5	50.5
54.0	56.0
59.0	61.0
64.0	66.0
69.0	71.0
79.0	81.0
89.0	91.0

Diameters & Lengths With () are not recommended for new design.

Thread Pitch	Thread Tolerance Plain 6g		
	Dia.	Pitch	Thread Tolerance Plated 6h
M1.6	0.35		Thread Tolerance Stainless 6g
M2	0.4		
M2.5	0.45	Material	4.8 A2 - A4
(M2.6)	0.45	Tensile Strength	60900 72500-101500
M3	0.5	Yield Strength	30450-65250
(M3.5)	0.6		
M4	0.7	Hardness	HRB NA
M5	0.8		
M6	1		
(M8)	1.25		
(M10)	1.5		
		Steel	Stainless Steel
		Property Class	4.8 A2 - A4
		Finish	Plain /Plated Plain

DIN 963 (1990)
ISO 2009 (1994)
ANSI B 18.16.7 M (1985) Do Not Specify A minimum Head Height

ANSI B 18.16.7 M (1985) Does Not Specify A Maximum Head Diameter

For Machine Screws, The Letter A After The DIN Number Indicates Full Thread. Unless Requested, All Machine Screws Are Supplied As Full Thread, Therefore We Omit The A.

FOR MORE DETAILED INFORMATION, PLEASE REFER TO COMPLETE DIN, ISO, JIS OR ANSI STANDARD, WHICH ARE THE GOVERNING STANDARDS

DIN 963 (1990) / ISO 2009 (1994) / JIS B1101 (1977) / ANSI B 18.16.7 M (1985) - LFG 10/01/2016 REVISED



Get quote >>

Angic Global Solutions

1-888-872-0690 Rights Reserved

https://www.AngicGlobal.com Sales@AngicGlobal.com

FLAT HEAD PHILLIPS MACHINE SCREWS - DIN 965 / ISO7046 / JIS B 1111 / ANSI B 18.6.7 M

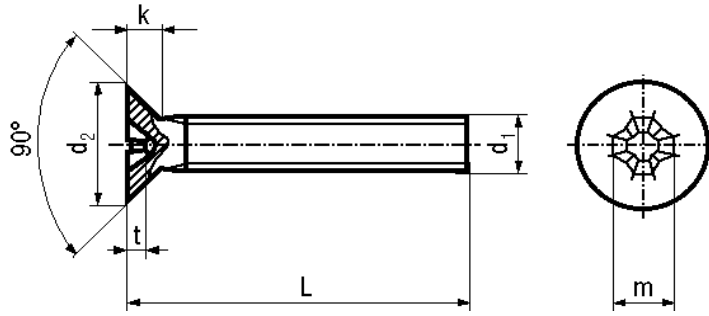

Head Diameter (d2)	Size d1	M2		M2.5		M3		(M3.5)		M4		M5		M6		M8		M10	
Standard		min.	max.	min.	max.	min.	max.	min.	max.	min.	max.	min.	max.	min.	max.	min.	max.	min.	max.
DIN 965 (1990)		3.50	3.80	4.40	4.70	5.30	5.60	6.14	6.50	7.14	7.50	8.84	9.20	10.57	11.00	14.07	14.50	17.57	18.00
ISO 7046 (1994)		3.50	3.80	4.40	4.70	5.20	5.50	6.94	7.30	8.04	8.40	8.94	9.30	10.87	11.30	15.37	15.80	17.78	18.30
JIS B 1111 (1977)			4.00	4.60	5.00	5.50	6.00	6.50	7.00	7.50	8.00	9.40	10.00	11.30	12.00	15.20	16.00		
ANSI B 18.16.7 M (1985)		3.50		4.40		5.20		6.90		8.00		8.90		10.90		15.40		17.80	

Head Height (k)	Size d1	M2		M2.5		M3		(M3.5)		M4		M5		M6		M8		M10	
Standard		min.	max.	min.	max.	min.	max.	min.	max.	min.	max.	min.	max.	min.	max.	min.	max.	min.	max.
DIN 965 (1990)			1.20		1.50		1.65		1.93		2.20		2.50		3.00		4.00		5.00
ISO 7046 (1994)			1.20		1.50		1.65		2.35		2.70		2.70		3.30		4.65		5.00
JIS B 1111 (1977)		1.00	1.20	1.25	1.45	1.45	1.75	1.70	2.00	2.00	2.30	2.50	2.80	3.00	3.40	4.00	4.40		
ANSI B 18.16.7 M (1985)			1.20		1.50		1.70		2.30		2.70		2.70		3.30		4.60		5.00

Cross Recess Size (m)	Size d1	M2	M2.5	M3	(M3.5)	M4	M5	M6	M8	M10
Standard										
DIN 965 (1990)			1			2		3		4
ISO 7046 (1994)		0		1		2		3		4
JIS B 1111 (1977)			1			2		3		
ANSI B 18.16.7 M (1985)		0		1		2		3		4

Cross Recess Penetration (t)	Size d1	M2		M2.5		M3		(M3.5)		M4		M5		M6		M8		M10	
Standard		min.	max.	min.	max.	min.	max.	min.	max.	min.	max.	min.	max.	min.	max.	min.	max.	min.	max.
DIN 965 (1990)		0.95	1.25	1.25	1.55	1.50	1.80	1.40	1.90	1.90	2.40	2.10	2.60	2.80	3.30	3.90	4.40	4.80	5.30
ISO 7046 (1994)		0.90	1.20	1.40	1.80	1.70	2.10	1.90	2.40	2.10	2.60	2.70	3.20	3.00	3.50	4.00	4.60	5.10	5.70
JIS B 1111 (1977)		0.65	1.01	1.05	1.42	0.91	1.43	1.40	1.93	1.79	2.33	2.38	2.93	2.70	3.26	4.36	4.96		
ANSI B 18.16.7 M (1985)		1.25	1.55	1.40	1.80	1.70	2.10	1.70	2.20	2.10	2.60	2.70	3.20	3.00	3.50	4.00	4.60	5.10	5.70

Length Tolerance	DIN965/ISO7046	
Nominal Length	min.	max.
2		
2.5		
3	2.80	3.20
4	3.76	4.24
5	4.76	5.24
6	5.76	6.24
8	7.71	8.29
10	9.71	10.29
12	11.65	12.35
(14)	13.65	14.35
16	15.65	16.35
(18)	17.65	18.35
20	19.58	20.42
(22)	21.58	22.42
25	24.58	25.42
(28)	27.58	28.42
30	29.58	30.42
35	34.50	35.50
40	39.50	40.50
45	44.50	45.50
50	49.50	50.50
(55)	54.05	55.95
60	59.05	60.95
(65)	64.05	65.95
70	69.05	70.95
(75)	74.05	75.95
80	79.05	80.95
90	88.90	91.10

JIS B 1111					
min.	max.	min.	max.	min.	max.
1.7	2.0				
2.7	3.0				
3.7	4.0				
4.6	5.0	4.4	5.0	4.2	5.0
5.6	6.0	5.4	6.0	5.2	6.0
7.6	8.0	7.4	8.0	7.2	8.0
9.6	10.0	9.4	10.0	9.2	10.0
11.4	12.0	11.4	12.0	11.0	12.0
15.4	16.0	15.4	16.0	15.0	16.0
19.4	20.0	19.4	20.0	19.0	20.0
24.2	25.0	24.2	25.0	24.0	25.0
29.2	30.0	29.2	30.0	29.0	30.0
34.2	35.0	34.2	35.0	34.0	35.0
39.2	40.0	39.2	40.0	39.0	40.0
		44.0	45.0	44.0	45.0
		49.0	50.0	49.0	50.0
		54.0	55.0	54.0	55.0
				59.0	60.0
				69.0	70.0
				79.0	80.0
				89.0	90.0

ANSI B 18.16.7 M	
min.	max.
2.3	2.7
2.8	3.2
3.7	4.3
4.7	5.3
5.7	6.3
7.7	8.3
9.7	10.3
11.7	12.3
15.7	16.3
19.5	20.5
24.5	25.5
29.5	30.5
34.5	35.5
39.5	40.5
44.5	45.5
49.5	50.5
54.0	56.0
59.0	61.0
64.0	66.0
69.0	71.0
79.0	81.0
89.0	91.0

Diameters & Lengths With () are not recommended for new design.

Thread Pitch		Thread Tolerance Plain 6g	
Dia.	Pitch	Thread Tolerance Plated 6h	
M1.6	0.35	Thread Tolerance Stainless 6g	
M2	0.4		
M2.5	0.45	Material	4.8 A2 - A4
(M2.6)	0.45	Tensile Strength	60900 72500-101500
M3	0.5	Yield Strength	49300 30450-65250
(M3.5)	0.6	Hardness	HRB NA
M4	0.7		
M5	0.8		
M6	1		
(M8)	1.25		
(M10)	1.5	Steel	Stainless Steel
		Property Class	4.8 A2 - A4
		Finish	Plain /Plated Plain

DIN 965 (1990)	Do Not Specify A Minimum Head Height
ISO 7046 (1994)	
ANSI B 18.16.7 M (1985)	

For Machine Screws, The Letter A After The DIN Number Indicates Full Thread. Unless Requested, All Machine Screws Are Supplied As Full Thread, Therefore We Omit The A.

FOR MORE DETAILED INFORMATION, PLEASE REFER TO COMPLETE DIN, ISO, JIS OR ANSI STANDARD, WHICH ARE THE GOVERNING STANDARDS

DIN 965 (1990) / ISO 7046 (1994) / JIS B1111 (1977) / ANSI B 18.16.7 M (1985) - LFG 10/01/2016 REVISED

OVAL HEAD PHILLIPS MACHINE SCREWS - DIN 966 / ISO7047 / JIS B 1111 / ANSI B 18.6.7 M

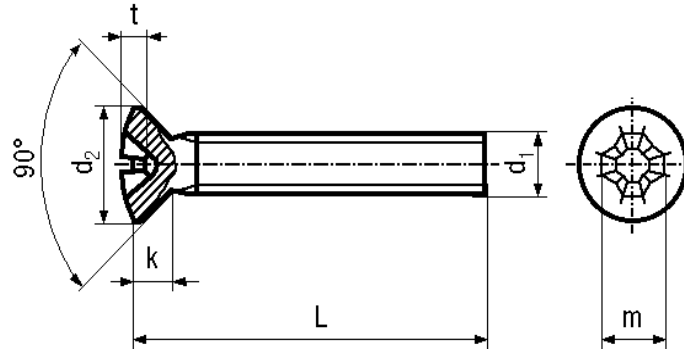

Head Diameter (d2)	Size d1	M1.6		M2		M2.5		M3		(M3.5)		M4		M5		M6		M8		M10	
Standard		min.	max.	min.	max.	min.	max.	min.	max.	min.	max.	min.	max.	min.	max.	min.	max.	min.	max.	min.	max.
DIN 966 (1990)		2.86	3.00	3.50	3.80	4.40	4.70	5.30	5.60	6.14	6.50	7.14	7.50	8.84	9.20	10.57	11.00	14.07	14.50	17.57	18.00
ISO 7047 (1994)		2.70	3.00	3.50	3.80	4.40	4.70	5.20	5.50	6.94	7.30	8.04	8.40	8.94	9.30	10.87	11.30	15.37	15.80	17.78	18.30
JIS B 1111 (1977)		2.80	3.20	3.60	4.00	4.60	5.00	5.50	6.00	6.50	7.00	7.50	8.00	9.40	10.00	11.30	12.00	15.20	16.00		
ANSI B 18.16.7 M (1985)				3.50		4.40		5.20		6.90		8.00		8.90		10.90		15.40		17.80	

Head Height (k)	Size d1	M1.6		M2		M2.5		M3		(M3.5)		M4		M5		M6		M8		M10	
Standard		min.	max.	min.	max.	min.	max.	min.	max.	min.	max.	min.	max.	min.	max.	min.	max.	min.	max.	min.	max.
DIN 966 (1990)			0.96		1.20		1.50		1.65		1.93		2.20		2.50		3.00		4.00		5.00
ISO 7047 (1994)			1.00		1.20		1.50		1.65		2.35		2.70		2.70		3.30		4.65		5.00
JIS B 1111 (1977)		0.85	0.95	1.00	1.20	1.25	1.45	1.45	1.75	1.70	2.00	2.00	2.30	2.50	2.80	3.00	3.40	4.00	4.40		
ANSI B 18.16.7 M (1985)					1.20		1.50		1.70		2.30		2.70		2.70		3.30		4.60		5.00

Cross Recess Size (m)	Size d1	M1.6	M2	M2.5	M3	(M3.5)	M4	M5	M6	M8	M10
Standard											
DIN 966 (1990)		0		1			2		3	4	
ISO 7047 (1994)			0		1		2		3	4	
JIS B 1111 (1977)				1			2		3		
ANSI B 18.16.7 M (1985)			0		1		2		3	4	

Cross Recess Penetration (t)	Size d1	M1.6		M2		M2.5		M3		(M3.5)		M4		M5		M6		M8		M10	
Standard		min.	max.	min.	max.	min.	max.	min.	max.	min.	max.	min.	max.	min.	max.	min.	max.	min.	max.	min.	max.
DIN 966 (1990)		0.74	1.10	1.10	1.40	1.30	1.60	1.70	2.00	1.74	2.24	2.04	2.54	2.77	3.27	3.03	3.53	4.18	4.68	5.38	5.88
ISO 7047 (1994)		0.90	1.20	1.20	1.50	1.50	1.85	1.80	2.20	2.25	2.75	2.70	3.20	2.90	3.40	3.50	4.00	4.75	5.25	5.50	6.00
JIS B 1111 (1977)				0.85	1.21	1.34	1.72	1.11	1.63	1.60	2.13	1.99	2.53	2.58	3.13	2.90	3.46	4.56	5.16		
ANSI B 18.16.7 M (1985)				1.40	1.70	1.56	1.96	2.03	2.43	1.93	2.43	2.48	2.98	3.19	3.69	3.55	4.05	4.93	5.53	6.27	6.87

Length Tolerance	DIN966/ISO7047	
Nominal Length	min.	max.
2		
2.5		
3	2.80	3.20
4	3.76	4.24
5	4.76	5.24
6	5.76	6.24
8	7.71	8.29
10	9.71	10.29
12	11.65	12.35
(14)	13.65	14.35
16	15.65	16.35
(18)	17.65	18.35
20	19.58	20.42
(22)	21.58	22.42
25	24.58	25.42
(28)	27.58	28.42
30	29.58	30.42
35	34.50	35.50
40	39.50	40.50
45	44.50	45.50
50	49.50	50.50
(55)	54.05	55.95
60	59.05	60.95
(65)	64.05	65.95
70	69.05	70.95
(75)	74.05	75.95
80	79.05	80.95
90	88.90	91.10

JIS B 1111					
min.	max.	min.	max.	min.	max.
1.7	2.0				
2.7	3.0				
3.7	4.0				
4.6	5.0	4.4	5.0	4.2	5.0
5.6	6.0	5.4	6.0	5.2	6.0
7.6	8.0	7.4	8.0	7.2	8.0
9.6	10.0	9.4	10.0	9.2	10.0
11.4	12.0	11.4	12.0	11.0	12.0
15.4	16.0	15.4	16.0	15.0	16.0
19.4	20.0	19.4	20.0	19.0	20.0
24.2	25.0	24.2	25.0	24.0	25.0
29.2	30.0	29.2	30.0	29.0	30.0
34.2	35.0	34.2	35.0	34.0	35.0
39.2	40.0	39.2	40.0	39.0	40.0
		44.0	45.0	44.0	45.0
		49.0	50.0	49.0	50.0
		54.0	55.0	54.0	55.0
				59.0	60.0
				69.0	70.0
				79.0	80.0
				89.0	90.0

ANSI B 18.16.7 M	
min.	max.
2.3	2.7
2.8	3.2
3.7	4.3
4.7	5.3
5.7	6.3
7.7	8.3
9.7	10.3
11.7	12.3
15.7	16.3
19.5	20.5
24.5	25.5
29.5	30.5
34.5	35.5
39.5	40.5
44.5	45.5
49.5	50.5
54.0	56.0
59.0	61.0
64.0	66.0
69.0	71.0
79.0	81.0
89.0	91.0

Diameters & Lengths With () are not recommended for new design.			
Thread Pitch	Thread Tolerance Plain 6g		
Thread Pitch	Thread Tolerance Plated 6h		
Di. Pitch	Thread Tolerance Stainless 6g		
M1.6	0.35		
M2	0.4		
M2.5	0.45	Material	4.8 A2 - A4
(M2.6)	0.45	Tensile Strength	60900 72500-101500
M3	0.5	Yield Strength	49300 30450-65250
(M3.5)	0.6	Hardness	HRB 71-99.5
M4	0.7		
M5	0.8		
M6	1		
(M8)	1.25		
(M10)	1.5	Steel	Stainless Steel
Property Class	4.8	A2 - A4	
Finish	Plain /Plated	Plain	

DIN 966 (1990)	Do Not Specify A
ISO 7047 (1994)	
ANSI B 18.16.7 M (1985)	Minimum Head Height

ANSI B 18.16.7 M (1985)	Does Not Specify A
	Maximum Head Diameter

For Machine Screws, The Letter A After The DIN Number Indicates Full Thread. Unless Requested, All Machine Screws Are Supplied As Full Thread, Therefore We Omit The A.

FOR MORE DETAILED INFORMATION, PLEASE REFER TO COMPLETE DIN, ISO, JIS OR ANSI STANDARD, WHICH ARE THE GOVERNING STANDARDS

DIN 966 (1990) / ISO 7047 (1994) / JIS B1111 (1977) / ANSI B 18.16.7 M (1985) - LFG 10/01/2016 REVISED

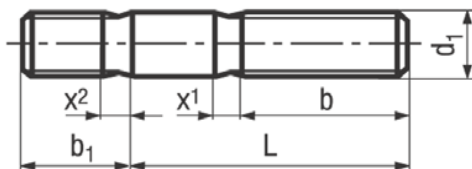

6.1 - DOUBLE END STUDS

DIN 939 (1995)	d1	M5	M6	M8	M10	M12	M16	M20	M24
				M8X1	M10X1.25	M12X1.25	M16X1.5	M20X1.5	M24X2
						M12X1.5			
For Lengths mm	b1	6.5	7.5	10	12	15	20	25	30
16	b	11	10.5	9.8					
(18)									
20		15	14.5	13.8	13.2				
(22)									
25		16	18	18.8	18.2	17.7			
30		16	18	22	23.2	22.7			
35		16	18	22	26	27.7	27		
40		16	18	22	26	30	32		
45		16	18	22	26	30	37	35.7	
50		16	18	22	26	30	38	40.7	39.5
55			18	22	26	30	38	45.7	
60			18	22	26	30	38	46	49.5
65			18	22	26	30	38	46	54
70			18	22	26	30	38	46	54
80			18	22	26	30	38	46	54
90			22	26	30	38	46	54	
100			22	26	30	38	46	54	
110			22	26	30	38	46	54	
120				26	30	38	46	54	
130				32	36		52		
140				32			52		
150								60	
	x1	2.00	2.50	3.20	3.80	4.30	5.00	6.30	7.50
	x2	1.00	1.25	1.60	1.90	2.20	2.50	3.20	3.80

Tap end length (b1) ~1.25 x d1

DIN 939 Studs require a Sk 6 Tolerance on the Tap End (B1) = Interference fit.

DIN 939 Fo Studs call for a 6g Tolerance on the Tap End (B1) = Normal thread Non Interference fit.

Examples of how to order Metric Studs - The Tap End (b1) length is not included in the OAL.

What size and type do you want?	How to call out order.
M8X30 OAL non interference fit DIN 939 Class 8.8 studs	M8X20 DIN 939-8.8 Fo Studs
M12X115 OAL non interference fit DIN 939 Class 8.8 studs	M12x100 DIN 939-8.8 Fo Studs

FOR MORE DETAILED INFORMATION, PLEASE REFER TO COMPLETE DIN STANDARD, WHICH IS THE GOVERNING STANDARD

DIN 939 FO (1995) - LFG 10/01/2016 REVISED

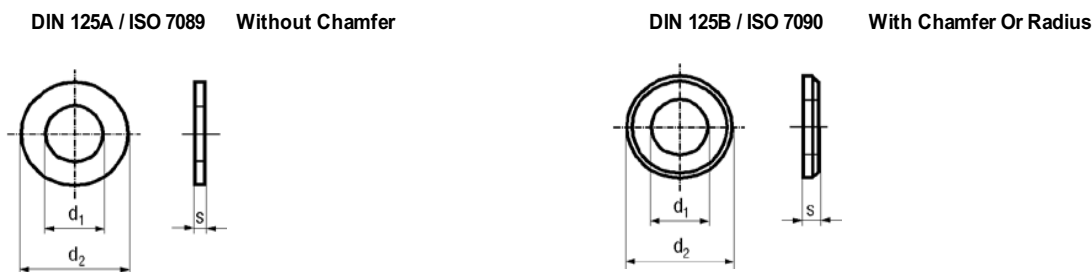

DIN125A&B/ ISO 7089 & 7090 Except As Noted								Not In ISO 7089 Or 7090	200 HV	300 HV
Screw Size	Hole Diameter d1		Outside Diameter d2		Thickness s			Except As Noted (No XXXX)	See Below For Stock	See Below For Stock
	min.= nominal	max.	min.	max.= nominal	nominal	min.	max.			
1	1.10	1.24	2.90	3.20	0.30	0.25	0.35	A2 Stainless Steel Only		
1.2	1.30	1.44	3.50	3.80	0.30	0.25	0.35			
1.4	1.60	1.74	3.50	3.80	0.30	0.25	0.35			
1.6	1.70	1.84	3.70	4.00	0.30	0.25	0.35			
1.7	1.80	1.94	4.20	4.50	0.30	0.25	0.35	(No 7089)		
2	2.20	2.34	4.70	5.00	0.30	0.25	0.35			
2.3	2.50	2.64	5.70	6.00	0.50	0.45	0.55	(No 7089)		
2.5	2.70	2.84	5.70	6.00	0.50	0.45	0.55			
2.6	2.80	2.94	6.64	7.00	0.50	0.45	0.55	(No 7089)		
3	3.20	3.38	6.64	7.00	0.50	0.45	0.55			
3.5	3.70	3.88	7.64	8.00	0.50	0.45	0.55			
4	4.30	4.48	8.64	9.00	0.80	0.70	0.90			
5	5.30	5.48	9.64	10.00	1.00	0.90	1.10		Yes	Yes
6	6.40	6.62	11.57	12.00	1.60	1.40	1.80		Yes	Yes
7	7.40	7.62	13.57	14.00	1.60	1.40	1.80	(No 7089/7090)		
8	8.40	8.62	15.57	16.00	1.60	1.40	1.80		Yes	Yes
10	10.50	10.77	19.48	20.00	2.00	1.80	2.20		Yes	Yes
12	13.00	13.27	23.48	24.00	2.50	2.30	2.70		Yes	Yes
14	15.00	15.27	27.48	28.00	2.50	2.30	2.70		Yes	Yes
16	17.00	17.27	29.48	30.00	3.00	2.70	3.30		Yes	Yes
18	19.00	19.33	33.38	34.00	3.00	2.70	3.30	(No 7089/7090)	Yes	Yes
20	21.00	21.33	36.38	37.00	3.00	2.70	3.30		Yes	Yes
22	23.00	23.33	38.38	39.00	3.00	2.70	3.30	(No 7089/7090)		
24	25.00	25.33	43.38	44.00	4.00	3.70	4.30		Yes	Yes
27	28.00	28.33	49.38	50.00	4.00	3.70	4.30	(No 7089/7090)		
30	31.00	31.39	55.26	56.00	4.00	3.70	4.30		Yes	Yes
33	34.00	34.62	58.80	60.00	5.00	4.40	5.60	(No 7089/7090)		
36	37.00	37.62	64.80	66.00	5.00	4.40	5.60			
39	40.00	40.62	70.80	72.00	6.00	5.40	6.60	(No 7089/7090)		
42	43.00	43.62	76.80	78.00	7.00	6.00	8.00	(No 7089/7090)		
45	46.00	46.62	83.60	85.00	7.00	6.00	8.00	(No 7089/7090)		
48	50.00	50.62	90.60	92.00	8.00	7.00	9.00	(No 7089/7090)		
52	54.00	54.74	96.60	98.00	8.00	7.00	9.00	(No 7089/7090)		
56	58.00	58.74	103.60	105.00	9.00	8.00	10.00	(No 7089/7090)		
64	66.00	66.74	113.60	115.00	9.00	8.00	10.00	(No 7089/7090)		
72	74.00	74.74	123.40	125.00	10.00	9.00	11.00	(No 7089/7090)		
80	82.00	82.87	138.40	140.00	12.00	10.80	13.20	(No 7089/7090)		
90	93.00	93.87	158.40	160.00	12.00	10.80	13.20	(No 7089/7090)		
100	104.00	104.87	173.40	175.00	14.00	12.80	15.20	(No 7089/7090)		

Material	Steel			A2/A4 Stainless Steel	Brass
Classes	140 HV	200 HV	300 HV	140 HV	NA
Hardness HV	140 min.	200-300	300-400	140 min.	NA
Finish	Plain Or Plated			Plain	Plain Or Nickel Plated

Type A Are Standard In Sizes 1.6mm Through 36mm Screw Size.
Type B Are Standard In Sizes 5mm Through 100mm Screw Size, But Are Not Supplied Below 39mm Screw Size, Except On Special Order. Chamfer Or Radius At Manufacturer's Option.

FOR MORE DETAILED INFORMATION, PLEASE REFER TO COMPLETE DIN OR ISO STANDARD, WHICH ARE THE GOVERNING STANDARDS

DIN 125A-125B (1990) / ISO 7089-7090 (1983) - LFG 10/01/2016 REVISED

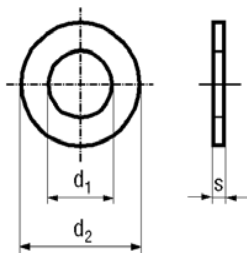

DIN 433 / ISO 7092 Except As Noted								Not In ISO 7092
Screw Size	Hole Diameter d1		Outside Diameter d2		Thickness s			Except As Noted (No ISO 7092)
	min.= nominal	max.	min.	max.= nominal	nominal	min.	max.	
1	1.10	1.24	2.25	2.50	0.30	0.25	0.35	(No 7092)
1.2	1.30	1.44	2.75	3.00	0.30	0.25	0.35	(No 7092)
1.4	1.50	1.64	2.75	3.00	0.30	0.25	0.35	(No 7092)
1.6	1.70	1.84	3.20	3.50	0.30	0.25	0.35	
2	2.20	2.34	4.20	4.50	0.30	0.25	0.35	
2.5	2.70	2.84	4.70	5.00	0.50	0.45	0.55	
3	3.20	3.38	5.70	6.00	0.50	0.45	0.55	
3.5	3.70	3.88	6.64	7.00	0.50	0.45	0.55	
4	4.30	4.48	7.64	8.00	0.50	0.45	0.55	
5	5.30	5.48	8.64	9.00	1.00	0.90	1.10	
6	6.40	6.62	10.57	11.00	1.60	1.40	1.80	
8	8.40	8.62	14.57	15.00	1.60	1.40	1.80	
10	10.50	10.77	17.57	18.00	1.60	1.40	1.80	
12	13.00	13.27	19.48	20.00	2.00	1.80	2.20	
14	15.00	15.27	23.48	24.00	2.50	2.30	2.70	
16	17.00	17.27	27.48	28.00	2.50	2.30	2.70	
18	19.00	19.33	29.48	30.00	2.50	2.30	2.70	(No 7092)
20	21.00	21.33	33.38	34.00	3.00	2.70	3.30	
24	25.00	25.33	38.38	39.00	4.00	3.70	4.30	
30	31.00	31.39 (1)	49.38	50.00	4.00	3.70	4.30	
36	37.00	37.62	56.8 (2)	58 (3)	5.00	4.40	5.60	

ISO 7092 Dimensions Identical To DIN 9021, Except As shown Below.			
30	31.33 (1)		
36		58.8 (2)	60 (3)

Material	Steel			A2/A4 Stainless Steel	Brass
Classes	140 HV	200 HV	300 HV (1)	140 HV	NA
Hardness HV	140 min.	200-300	300-400	140 min.	NA
Finish	Plain Or Plated			Plain	Plain Or Nickel Plated

(1) Chamfered Or Radius At Manufacturer's Option - Available As Special Order Only.

FOR MORE DETAILED INFORMATION, PLEASE REFER TO COMPLETE DIN OR ISO STANDARD, WHICH ARE THE GOVERNING STANDARDS

DIN 433 (1990) / ISO 7092 (1983) - LFG 10/01/10 REVISED

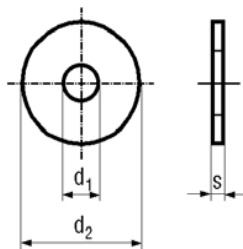

DIN 9021 / ISO 7093 Except As Noted								Not In ISO 7093
Screw Size	Hole Diameter d1		Outside Diameter d2		Thickness s			Except As Noted (No ISO 7093)
	min.= nominal	max.	min.	max.= nominal	nominal	min.	max.	
2.5	2.70	2.84	7.64	8.00	0.8	0.7	0.9	(No 7093)
3	3.20	3.38	8.64	9.00	0.8	0.7	0.9	
3.5	3.70	3.88	10.57	11.00	0.8	0.7	0.9	
4	4.30	4.48	11.57	12.00	1.0	0.9	1.1	
5	5.30	5.48	14.57	15.00	1.2	1.0	1.4	
6	6.40	6.62	17.57	18.00	1.6	1.4	1.8	
7	7.40	7.62	21.48	22.00	2.0	1.8	2.2	(No 7093)
8	8.40	8.62	23.48	24.00	2.0	1.8	2.2	
10	10.50	10.77	29.48	30.00	2.5	2.3	2.7	
12	13.00	13.27	36.38	37.00	3.0	2.7	3.3	
14	15.00	15.27	43.38	44.00	3.0	2.7	3.3	
16	17.00	17.27	49.38	50.00	3.0	2.7	3.3	
18	20.00	20.52	54.10	56.00	4.0	3.4	4.6	(No 7093)
20	22.00	22.52	58.10	60.00	4.0	3.4	4.6	
24	26.00	26.84	70.10	72.00	5.0	4.0	6.0	
30	33.00	34.00	89.80	92.00	6.0	5.0	7.0	
36	39.00	40.00	107.80	110.00	8.0	6.8	9.2	

Material	Steel		A2/A4 Stainless Steel
	Sizes ≤16mm	Sizes >16mm	All Sizes
Classes	140 HV	100 HV	140 HV
Hardness HV	140-250	100-250	140-250
Finish	Plain Or Plated		Plain

These Washers Are Commonly Referred To As Fender Washers

OD Of These Washers Is ~ 3X The Screw Size Diameter

7.3 - FLAT WASHERS - LARGE SERIES

FOR MORE DETAILED INFORMATION, PLEASE REFER TO COMPLETE DIN OR ISO STANDARD, WHICH ARE THE GOVERNING STANDARDS

DIN 9021 (1990) / ISO 7093 (1983) - LFG 10/01/10 REVISED

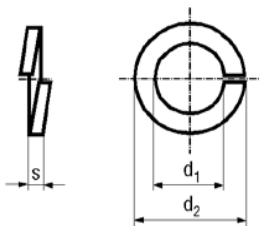

Screw Size	DIN 127 Type B - With Square Ends					DIN 7980 - With Square Ends				
	Hole Diameter d1		Outside Diameter d2	Thickness s	Thickness Tolerance	Hole Diameter d1		Outside Diameter d2	Thickness s	Thickness Tolerance
	min.	max.				min.	max.			
2	2.1	2.4	4.4	0.5	+/-0.1					
2.2	2.3	2.6	4.8	0.6	+/-0.1					
2.5	2.6	2.9	5.1	0.6	+/-0.1					
3	3.1	3.4	6.2	0.8	+/-0.1	3.1	3.4	5.6	1.0	+/-0.1
(3.5)	3.6	3.9	6.7	0.8	+/-0.1	3.6	3.9	6.1	1.0	+/-0.1
4	4.1	4.4	7.6	0.9	+/-0.1	4.1	4.4	7.0	1.2	+/-0.1
5	5.1	5.4	9.2	1.2	+/-0.1	5.1	5.4	8.8	1.6	+/-0.1
6	6.1	6.5	11.8	1.6	+/-0.1	6.1	6.5	9.9	1.6	+/-0.1
7	7.1	7.5	12.8	1.6	+/-0.1					
8	8.1	8.5	14.8	2.0	+/-0.1	8.1	8.5	12.7	2.0	+/-0.1
10	10.2	10.7	18.1	2.2	+/-0.15	10.2	10.7	16.0	2.5	+/-0.15
12	12.2	12.7	21.1	2.5	+/-0.15	12.2	12.7	18.0	2.5	+/-0.15
14	14.2	14.7	24.1	3.0	+/-0.15	14.2	14.7	21.1	3.0	+/-0.2
16	16.2	17.0	27.4	3.5	+/-0.2	16.2	17.0	24.4	3.5	+/-0.2
(18)	18.2	19.0	29.4	3.5	+/-0.2	18.2	19.0	26.4	3.5	+/-0.2
20	20.2	21.2	33.6	4.0	+/-0.2	20.2	21.2	30.6	4.5	+/-0.2
(22)	22.5	23.5	35.9	4.0	+/-0.2	22.5	23.5	32.9	4.5	+/-0.2
24	24.5	25.5	40.0	5.0	+/-0.2	24.5	25.5	35.9	5.0	+/-0.2
(27)	27.5	28.5	43.0	5.0	+/-0.2	27.5	28.5	38.9	5.0	+/-0.2
30	30.5	31.7	48.2	6.0	+/-0.2	30.5	31.7	44.1	6.0	+/-0.2
(33)	33.5	34.7	55.2	6.0	+/-0.2	33.5	34.7	47.1	6.0	+/-0.2
36	36.5	37.7	58.2	6.0	+/-0.2	36.5	37.7	52.2	7.0	+/-0.25
(39)	39.5	40.7	61.2	6.0	+/-0.2					
42	42.5	43.7	68.2	7.0	+/-0.25	42.5	43.7	60.2	8.0	+/-0.25
(45)	45.5	46.7	71.2	7.0	+/-0.25					
48	49.0	50.5	75.0	7.0	+/-0.25	49.0	50.5	67.0	8.0	+/-0.25
52	53.0	54.5	83.0	8.0	+/-0.25					
56	57.0	58.5	87.0	8.0	+/-0.25					
(60)	61.0	62.5	91.0	8.0	+/-0.25					
64	65.0	66.5	95.0	8.0	+/-0.25					
68	69.0	70.5	99.0	8.0	+/-0.25					
72	73.0	74.5	103.0	8.0	+/-0.25					
80	81.0	82.5	111.0	8.0	+/-0.25					
90	91.0	92.5	121.0	8.0	+/-0.25					
100	101.0	102.5	131.0	8.0	+/-0.25					

DIN 7980 Lock Washers Are Designed For Use With Cheese Head Screws And Or Socket Head Cap Screws Because Of The Smaller OD max.

Sizes With () Should be Avoided For New Design.

Not All Diameters In DIN 127 B And DIN 7980 Available In All Materials.

Material	Spring Steel	A2 Stainless	A4 Stainless	Phosphor Bronze	(1) Mechanical, Organic, Or Electro Zinc Plated At Manufacturer's Option.
Hardness	HRC 44-51	NA	NA	NA	
Finish	Plain / Plated (1)	Plain	Plain	Plain	

FOR MORE DETAILED INFORMATION, PLEASE REFER TO COMPLETE DIN STANDARD, WHICH IS THE GOVERNING STANDARD

DIN 127 B (1987) / DIN 7980 (1987) - LFG 10/01/10 REVISED

DIN 6797 Type A Externally Toothed

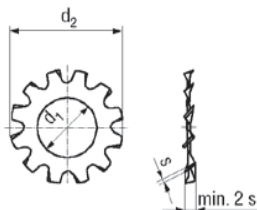

DIN 6797 Type J Internally Toothed

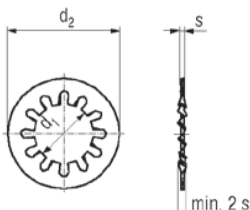

Screw Size	Hole Diameter d1		OD Diameter d2		Material Thickness s	Minimum # Of Teeth	Washer Thickness min.	Below Applies To Both DIN 6797 And DIN 6798			
	min.= nominal	max.	min.	max.= nominal							
1.6	1.70	1.84	3.30	3.6	0.3	6	0.6	Sizes With () Should be Avoided For New Design.			
2	2.20	2.34	4.20	4.5	0.3	6	0.6				
2.5	2.70	2.84	5.20	5.5	0.4	6	0.8				
3	3.20	3.38	5.70	6.0	0.4	6	0.8	(1) Mechanical, Organic, Or Electro Zinc Plated At Manufacturer's Option.			
(3.5)	3.70	3.88	6.64	7.0	0.5	6	1.0				
4	4.30	4.48	7.64	8.0	0.5	8	1.0	Material			
5	5.30	5.48	9.64	10.0	0.6	8	1.2				
6	6.40	6.62	10.57	11.0	0.7	8	1.4	Hardness			
7	7.40	7.62	12.07	12.5	0.8	8	1.6				
8	8.40	8.62	14.57	15.0	0.8	8	1.6	Finish			
10	10.50	10.77	17.57	18.0	0.9	9	1.8				
12	13.00	13.27	19.98	20.5	1.0	10	2.0	Not All Diameters In DIN 6797 And DIN 6798 Available In All Materials.			
14	15.00	15.27	23.48	24.0	1.0	10	2.0				
16	17.00	17.27	25.48	26.0	1.2	12	2.4				
(18)	19.00	19.33	29.48	30.0	1.4	12	2.8				
20	21.00	21.33	32.38	33.0	1.4	12	2.8				
(22)	23.00	23.33	35.38	36.0	1.5	14	3.0				
24	25.00	25.33	37.38	38.0	1.5	14	3.0				
(27)	28.00	28.33	43.38	44.0	1.6	14	3.2				
30	31.00	31.39	47.38	48.0	1.6	14	3.2				

DIN 6798 Type A Externally Toothed

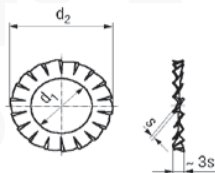

DIN 6798 Type J Internally Toothed

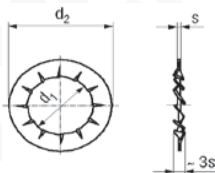

DIN 6798 Type V Externally Toothed

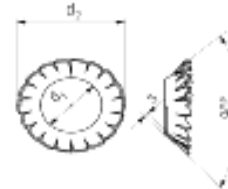

Hole ID For Type V Is The Same As For Type A & J

Screw Size	Hole Diameter d1		OD Diameter d2		Material Thickness s	Minimum # Of Teeth		Washer Thickness min.	Type V OD Diameter d2	Type V Material Thickness s
	min.= nominal	max.	min.	max.= nominal		Type A	Type J			
1.6	1.70	1.84	3.30	3.6	0.3	9	7	0.9		
2	2.20	2.34	4.20	4.5	0.3	9	7	0.9	~4.2	0.20
2.5	2.70	2.84	5.20	5.5	0.4	9	7	1.2	~5.1	0.20
3	3.20	3.38	5.70	6.0	0.4	9	7	1.2	~6	0.20
(3.5)	3.70	3.88	6.64	7.0	0.5	10	8	1.5	~7	0.25
4	4.30	4.48	7.64	8.0	0.5	11	8	1.5	~8	0.25
5	5.30	5.48	9.64	10.0	0.6	11	8	1.8	~9.8	0.30
6	6.40	6.62	10.57	11.0	0.7	12	9	2.1	~11.8	0.40
7	7.40	7.62	12.07	12.5	0.8	14	10	2.4		
8	8.40	8.62	14.57	15.0	0.8	14	10	2.4	~15.3	0.40
10	10.50	10.77	17.57	18.0	0.9	16	12	2.7	~19	0.50
12	13.00	13.27	19.98	20.5	1.0	16	12	3.0	~23	0.50
14	15.00	15.27	23.48	24.0	1.0	18	14	3.0	~26.2	0.60
16	17.00	17.27	25.48	26.0	1.2	18	14	3.6	~30.2	0.60
(18)	19.00	19.33	29.48	30.0	1.4	18	14	4.2		
20	21.00	21.33	32.38	33.0	1.4	20	16	4.2		
(22)	23.00	23.33	35.38	36.0	1.5	20	16	4.5		
24	25.00	25.33	37.38	38.0	1.5	20	16	4.5		
(27)	28.00	28.33	43.38	44.0	1.6	22	18	4.8		
30	31.00	31.39	47.38	48.0	1.6	22	18	4.8		

FOR MORE DETAILED INFORMATION, PLEASE REFER TO COMPLETE DIN STANDARD, WHICH ARE THE GOVERNING STANDARDS

DIN 6797 (1988) / DIN 6798 (1988) - LFG 10/01/10 REVISED

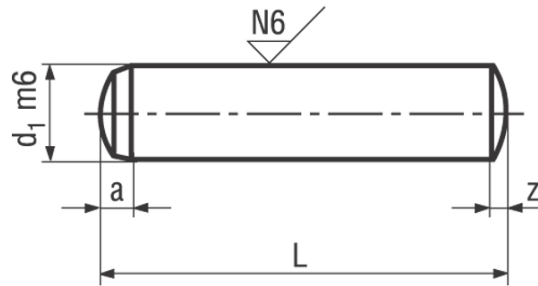

Nominal Diameter d1	1	1.5	2	2.5	3	4	5	6
min. d1	1.002	1.502	2.002	2.502	3.002	4.004	5.004	6.004
max. d1	1.008	1.508	2.008	2.508	3.008	4.012	5.012	6.012
a~	0.4	0.5	0.6	0.7	0.8	1	1.2	1.5
z~	0.15	0.23	0.3	0.4	0.45	0.6	0.75	0.9
Hardened Steel, Single Shear Strength In lbs.	NA	418	742	1,158	1,664	2,968	4,631	6,677
Suggested Hole Size min.	1.000	1.500	2.000	2.500	3.000	4.000	5.000	6.000
Suggested Hole Size max.	1.010	1.510	2.010	2.510	3.010	4.012	5.012	6.012

Nominal Diameter d1	8	10	12	(14)	16	20	(24)
min. d1	8.006	10.006	12.007	14.007	16.007	20.008	24.008
max. d1	8.015	10.015	12.018	14.018	16.018	20.021	24.021
a~	1.8	2	2.5	2.5	3	4	
z~	1.2	1.5	1.8	2	2.5	3	
Hardened Steel, Single Shear Strength in lbs.	11,803	18,548	26,754	NA	47,437	74,191	NA
Suggested Hole Size min.	8.000	10.000	12.000	14.000	16.000	20.000	24.000
Suggested Hole Size max.	8.015	10.015	12.018	14.018	16.018	20.021	24.021

Suggested Hole Diameter Based on H7 Tolerance To Match m6 Pin Tolerance	Length Tolerance		
	+/- 0.25mm	+/- 0.50mm	+/- 0.75mm
	Through 10mm	From 12mm Through 50mm	55mm and Longer

14mm, and 24mm Diameters Are Not Included in ISO 8734, And Are Not Recommended For New Design.

Shear Strength Data Is Not Published For 1mm, 14mm, And 24mm-So Would Only Be Available With Laboratory Test Reports.

Rockwell Hardness	DIN 6325m6	ISO 8734A	To Eliminate Inspection Issues During Transition From DIN to ISO We Suggest Accepting HRC 52-62 For Either DIN or ISO.
	HRC 60 +/-2	HRC 52-58	

DIN 6325 Dowel Pins Are Through Hardened.

FOR MORE DETAILED INFORMATION, PLEASE REFER TO COMPLETE DIN OR ISO STANDARD, WHICH ARE THE GOVERNING STANDARDS

DIN 6325M (1971) / ISO 8734 (1997) - LF6 01/01/13 REVISED

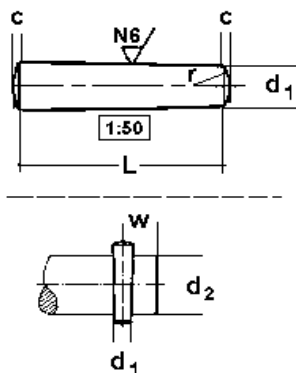

Dimensions For DIN 1B and ISO 2339 B Are Basically The Same But The Measurement of the Pin Is Not The Same. See Below "How To Measure Taper Pin Length".

Diameter d1	0.6	0.8	1	1.5	2	(2.5)	3	4	5	6	8	10	12	16
Rounded end c	0.08	0.1	0.12	0.2	0.25	0.3	0.4	0.5	0.63	0.8	1	1.2	1.6	2
h10 Tolerance	+0 / -0.04						+0 / -0.048			+0 / -0.058		+0 / -0.07		
Hole Drill Size	0.6	0.8	1	1.5	2	(2.5)	3	4	5	6	8	10	12	16
Taper Pin Reamer Size	0.6	0.8	1	1.5	2	(2.5)	3	4	5	6	8	10	12	16
End of shaft to pin center (min.) w	2	2.5	3	3.5 4	4.5	5	5	6	7.5	9	10 ≥38 11	11.5 ≥50 13	15	18

There are some Minor Non-Functional Differences Between the DIN and ISO Version. Currently The DIN Is The Most Prevalent Standard, But Either Version May Be Supplied.

How To Measure Taper Pin Length

For DIN 1 B (Free Cutting Steel h10), the length is considered to be the length of the taper portion, not to include the rounded ends.

For ISO 2339 B (Free Cutting Steel h10), the length is considered to be the length of the taper portion including the rounded ends, or end to end.

DIN 1B Length Tolerance js15	DIN 1 B Examples	Over All Length Will Be
Through 3mm long	+/- 0.20mm	
Through 6mm long	+/- 0.24mm	
Through 10mm long	+/- 0.29mm	2mm x 10mm +/-0.29mm + 2 x 0.25mm = 10.21mm min 10.79mm max.
Through 18mm long	+/- 0.35mm	
Through 30mm long	+/- 0.42mm	
Through 50mm long	+/- 0.50mm	8mm x 50mm +/-0.50mm + 2 x 1mm = 51.50mm min. 52.50mm max.
Through 80mm long	+/- 0.60mm	
Through 120mm long	+/- 0.70mm	12mm x 120mm +/-0.70mm + 2 x 1.6mm = 122.50mm min. 123.90mm max.
Large End Diameter		
The diameter of the large end increases by 1mm for every 50mm in length		

Examples:	6mm x 40 would have a large diameter of 6.8mm
	8mm x 50 would have a large diameter of 9mm
	12mm x 80 would have a large diameter of 13.6mm

(40mm/50mm=0.8, so 6mm plus 0.8mm = 6.8mm)
(50mm/50mm=1, so 8mm plus 1mm = 9mm)
(80mm/50mm=1.6, so 12mm plus 1.6mm = 13.6mm)

FOR MORE DETAILED INFORMATION, PLEASE REFER TO COMPLETE DIN OR ISO STANDARD, WHICH ARE THE GOVERNING STANDARDS

DIN 1 B (1961) / -ISO 2339B (1986) - LF6 REVISED 01/01/2013

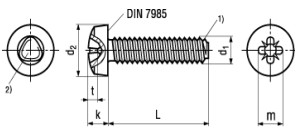

Pan Pozidriv® Type C

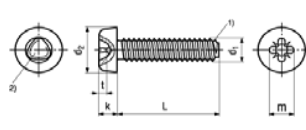

Cheese Pozidriv®

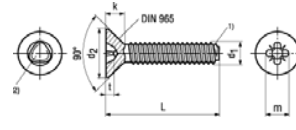

Flat Pozidriv® Type M

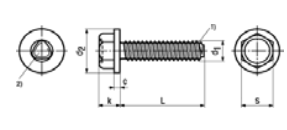

Hex Washer Type D

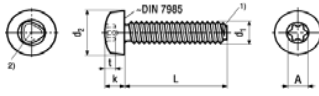

6 Lobe Pan Type C

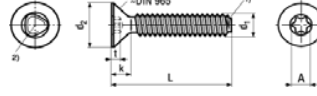

6 Lobe Flat Type M

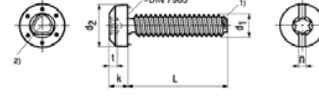

6 Lobe/Slot Pan

Head Diameter d2 max.	M2	M2.5	M3	M3.5	M4	M5	M6	M8
Pan Pozidriv® Type C		5.00	6.00		8.00	10.00	12.00	
Cheese Pozidriv®		4.50	5.50	6.00	7.00	8.50	10.00	
Flat Pozidriv® Type M		4.70	5.60		7.50	9.20	11.00	
Hex Washer Type D					8.90	10.40	13.00	17.00
6 Lobe Pan Type C	4.00	5.00	6.00		8.00	10.00	12.00	16.00
6 Lobe/Slot Pan			6.00		8.00			
6 Lobe Flat Type M	3.80	4.70	5.60		7.50	9.20	11.00	14.50

Head Height k max.	M2	M2.5	M3	M3.5	M4	M5	M6	M8
Pan Pozidriv® Type C		2.12	2.52		3.25	3.95	4.75	
Cheese Pozidriv®		1.90	2.30	2.70	2.90	3.70	4.30	
Flat Pozidriv® Type M		1.50	1.65		2.20	2.50	3.00	
Hex Washer Type D					4.23	5.25	6.25	8.35
6 Lobe Pan Type C	1.72	2.12	2.52		3.25	3.95	4.75	6.15
6 Lobe/Slot Pan			2.52		3.25			
6 Lobe Flat Type M	1.20	1.50	1.65		2.20	2.50	3.00	4.00

Driver Size / WAF (s)	M2	M2.5	M3	M3.5	M4	M5	M6	M8
Pan Pozidriv® Type C		1	1		2	2	3	
Cheese Pozidriv®		1	1	2	2	2	3	
Flat Pozidriv® Type M		1	1		2	2	3	
Hex Washer Type D					7	8	10	13
6 Lobe Pan Type C	X6	X8	X10		X20	X25	X30	X40
6 Lobe/Slot Pan			X10		X20			
6 Lobe Flat Type M	X6	X8	X10		X20	X25	X30	X40

Penetration Depth / Washer Thickness	M2		M2.5		M3		M3.5		M4		M5		M6		M8	
	min.	max.	min.	max.	min.	max.	min.	max.	min.	max.	min.	max.	min.	max.	min.	max.
Pan Pozidriv® Type C			1.27	1.52	1.68	1.93			1.90	2.38	2.64	3.10	3.02	3.48		
Cheese Pozidriv®			1.10	1.35	1.60	1.85	1.50	1.75	1.90	2.35	2.30	2.75	2.50	2.97		
Flat Pozidriv® Type M			1.22	1.47	1.48	1.73			1.60	2.06	2.05	2.51	2.46	2.92		
Hex Washer Type D									0.65	0.80	1.05	1.35				
6 Lobe Pan Type C		0.80		1.20		1.30				1.80		2.00		2.40		3.30
6 Lobe/Slot Pan						1.20			1.90							
6 Lobe/Slot Pan (Slot)						0.60			1.00							
6 Lobe Flat Type M		0.70		1.00		1.00				1.40		1.50		1.90		3.30

FOR MORE DETAILED INFORMATION, PLEASE REFER TO BOSSARD BN 2723, 2724, 3326, 3327, 11288, 13916, 14551 WHICH ARE THE GOVERNING STANDARDS

©2016 BY BOSSARD - LFG 10/01/2016

GENERAL INFORMATION FOR METRIC FASTENERS

DIN - German Institute For Standards

This is still the most used and popular standard for metric fasteners world wide. A lot of the DIN Standards are being revised to more closely mirror the ISO Standards, but that is an ongoing procedure.

ISO - International Standards Organization

For metric fasteners this is probably the 2nd most used or referenced standard today, but in comparison the number of ISO Standards vs. DIN Standards is quite small.

JIS - Japanese Industrial Standards Institute

Many JIS Standards have been revised to comply with the DIN Standards, but that does not seem to follow the demand for JIS metric fasteners, as most demand for JIS metric fasteners is to the old JIS Standard.

ANSI - American National Standards Institute

ANSI provides the coordination to ensure the various organizations developing standards avoid duplication and confusion. ANSI's entry into the field of metric fasteners was well superseded by both DIN and ISO.

IFI - Industrial Fastener Institute

IFI is one of the various organizations developing standards. IFI Standards are not recognized worldwide, and are normally superseded by ANSI Standards.

Other Less Popular World Standards

AFNOR	BSI	DGN	NNI	SCC	SIS	SN (VSM)	UNI
France	Great Britain	Mexico	Netherlands	Canada	Sweden	Switzerland	Italy

With the exception of Socket Screws all threads from the Standards shown are interchangeable.

Thread Measurement - Metric Fasteners Pitch vs. Inch Fasteners Threads Per Inch (TPI)

Metric Product - Pitch is determined by the distance from the crest of one thread to the crest of the next thread. In metric, fine pitch is always a smaller number than coarse pitch, because the distance from the crest of one thread to the crest of the next thread is a smaller number. Example M8 x 1.25 = coarse pitch and M8 x1.0 = fine pitch.

Inch Product - TPI is the actual number of threads per one inch, so for inch fasteners the fine thread fastener will have a higher number than the coarse thread fastener, because there will be more threads in that one inch. Example 5/16-18 (18TPI) = Coarse Thread and 5/16-24 (24TPI) = fine thread.

Some Metric rules but they are not always adhered to in the United States.

For metric fasteners, **coarse pitch** does not need to be called out because it is assumed, but for **fine pitch**, it must be called out as there are several fine pitches for some diameters.

Tensile Strength and Yield Strength - When referring to either tensile or yield strength you should not use commas. Example minimum tensile strength 176900 PSI, not 176,900 PSI. To convert **Megapascals (MPa)** to **PSI** use the conversion factor 145 - Example 1220 MPa x 145 = 176900 PSI.

Inch to Metric conversion - 1 inch = 25.4 mm - Example 4 inch length bolt converted to metric 4 x 25.4 = 101.6 mm, so you use a 100mm bolt or screw. **1 meter** = 39.37 inches or just a little over 1 yard (36").

Common Lengths In Metric				Metric Gauging			
M3 x 3	Increments of 1mm	M6 x 25	Increments of 5mm	M20 x 80	Metric male thread plain	6g ring gage	
M3 x 4		M6 x (28)		M20 x 90			
M3 x 5		M6 x 30		M20 x 100	Metric male thread plated	6h ring gage	
M3 x 6		M6 x 35		M20 x 110			
M6 x 6 M6 x 8 M6 x 10 M6 x 12 M6 x (14) M6 x 16 M6 x (18) M6 x 20 M6 x (22)	Increments of 2mm	M6 x 40		Increments of 10mm	M20 x 120	Metric nut plain/plated	6H plug gage
		M6 x 45			M20 x 130		
		M6 x 50			M20 x 140	Metric DIN 912 Socket	5g6g ring gage
		M6 x 55			M20 x 150		
		M6 x 60			M20 x 160	Metric ISO 4762 Sockets	5g6g ring gage
		M6 x 65			M20 x 180		
		M6 x 70	M20 x 200		Metric ANSI Sockets	4g6g ring gage	
		M6 x (75)	M20 x 220				
M6 x 80	M20 x 240						
	M20 x 260						
The lengths shown here do not apply to Dowel Pins				Increments of 20mm	Tolerance For Fits and Threads		
					Tolerance for fits	h6, m6, H7, H9	
					Note that letters and numbers are reversed.		
					Tolerance for threads	6h, 6g, 6H, 6G	

THREADED BRASS FASTENERS ARE FUNCTIONAL PRODUCTS ONLY

AS BRASS IS VERY SOFT, SUPPLIERS OF THIS MATERIAL TO LINDSTROM WILL NOT GUARANTEE THREAD TOLERANCE TO EITHER 6G, 6H, OR 6H

GENERAL INFORMATION - LFG 10/01/2016 REVISED



Angic Global Solutions

1-888-872-0690 Rights Reserved

<https://www.AngicGlobal.com> Sales@AngicGlobal.com

THREAD PITCHES (COARSE AND FINE) - METRIC PREFERENCE CLASSES

METRIC COARSE & FINE THREAD PITCHES					
Diameter	Coarse Pitch C	Fine Pitch F	Extra Fine Pitch X	Super Fine Pitch S	Very Fine Pitch V
M1	0.25	0.2			
M1.2	0.25	0.2			
M1.4	0.3	0.2			
M1.6	0.35	0.2			
M1.7	0.35				
M1.8	0.35	0.2			
M2	0.4	0.25			
M2.2	0.45	0.25			
M2.3	0.4				
M2.5	0.45	0.35			
M2.6	0.45				
M3	0.5	0.35			
M3.5	0.6	0.35			
M4	0.7	0.5			
M5	0.8	0.5			
M6	1	0.75			
M7	1	0.75			
M8	1.25	1	0.75		
M9	1.25	1	0.75		
M10	1.5	1.25	1	0.75	
M11	1.5	1	0.75		
M12	1.75	1.5	1.25	1	
M14	2	1.5	1.25	1	
M16	2	1.5	1		
M18	2.5	2	1.5	1	
M20	2.5	2	1.5	1	
M22	2.5	2	1.5	1	
M24	3	2	1.5	1	
M27	3	2	1.5	1	
M30	3.5	3	2	1.5	1
M33	3.5	3	2	1.5	
M36	4	3	2	1.5	
M39	4	3	2	1.5	
M42	4.5	4	3	2	1.5
M45	4.5	4	3	2	1.5
M48	5	4	3	2	1.5
M52	5	4	3	2	1.5
M56	5.5	4	3	2	1.5
M60	5.5	4	3	2	1.5
M64	6	4	3	2	1.5
M68	6	4	3	2	1.5
M72	6	4	3	2	1.5
M80	6	4	3	2	1.5
M90	6	4	3	2	1.5
M100	6	4	3	2	1.5

METRIC THREAD PREFERENCE CLASSES APPLY TO COARSE PITCH ONLY					FINE PITCH SHOULD NOT BE USED IN NEW DESIGN
Diameter	Class 1	Class 2	Class 3	Just Don't Use	
M1	X				X
M1.2	X				X
M1.4		X			X
M1.6	X				X
M1.7				X	X
M1.8				X	X
M2	X				X
M2.2		X			X
M2.3				X	X
M2.5	X				X
M2.6			X		X
M3	X				X
M3.5		X			X
M4	X				X
M5	X				X
M6	X				X
M7			X		X
M8	X				X
M9				X	X
M10	X				X
M11				X	X
M12	X				X
M14	X	X			X
M16	X				X
M18		X			X
M20	X				X
M22		X			X
M24	X				X
M27		X			X
M30	X				X
M33		X			X
M36	X				X
M39			X		X
M42	X				X
M45				X	X
M48	X				X
M52			X		X
M56	X				X
M60			X		X
M64	X				X
M68			X		X
M72	X				X
M80	X				X
M90	X				X
M100	X				X

10.2 - THREAD PITCHES & PREFERENCE CLASSES

It is The Practice In The Metric System To Not Show The Pitch When Dealing In Coarse Threads. EXAMPLE : If You Wanted To Indicate M12 With A Coarse Pitch (1.75) You Would Write or Say Just M12.

SCREWS WITH ANY FINE PITCH SHOULD NOT BE USED IN NEW DESIGN - ALSO SEE REFERENCE AT TOP OF PAGE

DIN BOOK 45 - PITCHES & METRIC THREAD PREFERENCES - LFG 10/01/2016 REVISED



MECHANICAL PROPERTIES FOR BOLTS AND SCREWS

Steel Property Class 3.6 Through 12.9	Tensile Strength min. (psi)	Yield Strength min. (psi)		Vickers Hardness (HV)	Brinell Hardness (HB)	Rockwell Hardness (HRB)	Rockwell Hardness (HRC)	Similar To
3.6	47850	28710	min.	95	90	52	NA	
			max.	250	238	99.5	NA	
4.6	58000	34800	min.	120	114	67	NA	
			max.	250	238	99.5	NA	
4.8	60900	49300	min.	130	124	71	NA	
			max.	250	238	99.5	NA	
5.6	72500	58000	min.	155	147	79	NA	
			max.	250	238	99.5	NA	
5.8	75400	60900	min.	160	152	82	NA	Grade 2
			max.	250	238	99.5	NA	
6.8	87000	69600	min.	190	181	89	NA	
			max.	250	238	99.5	NA	
8.8 ≤16mm	116000	92800	min.	250	238	NA	22	Grade 5
			max.	320	304	NA	32	
8.8 >16mm	120350	95700	min.	255	242	NA	23	
			max.	335	318	NA	34	
9.8	130500	104400	min.	290	276	NA	28	Above Grade 5
			max.	360	342	NA	37	
10.9	150800	136300	min.	320	304	NA	32	Grade 8
			max.	380	361	NA	39	
12.9	176900	159500	min.	385	366	NA	39	ASTM A574
			max.	435	414	NA	44	
Tensile Strength (psi)								
	min.	max.						
90	130500	159500	min.	280	268	NA	27	Above Grade 5
			max.	340	323	NA	34	
100	145000	174000	min.	320	304	NA	32	Grade 8
			max.	370	352	NA	38	
Stainless Steel Grades A1 - A2 - A4	Tensile Strength min. (psi)	Yield Strength min. (psi)	Hardness					Similar To
Property Class 50	72500	30450	Vickers, Brinell or Rockwell Hardness Are Not Measurable Factors For Stainless Steel					A1 Stnl Steel ~ Free Cutting Stn Steel
Property Class 70	101500	65250						A2 Stnl Steel ~ 18-8 Stnl Steel
Property Class 80	116000	87000						A4 Stnl Steel ~ 316 Stnl Steel
Brass	Tensile Strength min. (psi)	Yield Strength min. (psi)	Hardness					
Ms 63	53000		Vickers, Brinell or Rockwell Hardness Are Not Measurable Factors For Brass					
Ms 58	55000							

HYDROGEN EMBRITTLEMENT WITH HARDENED FASTENERS

LINDSTROM METRIC, LLC AND MEGA METRIC, DIVISION OF LINDSTROM METRIC, LLC REQUIRES OUR PLATERS AND SUPPLIERS OF PLATED FASTENERS TO BAKE QUALIFIED HARDENED PRODUCTS. HOWEVER, THERE IS NO PLATING PROCESS WHICH WILL GUARANTEE COMPLETE FREEDOM FROM HYDROGEN EMBRITTLEMENT. THEREFORE, LINDSTROM METRIC AND MEGA METRIC CANNOT BE HELD LIABLE FOR ANY LOSS OR DAMAGE WHICH OCCURS AS A RESULT OF HYDROGEN EMBRITTLEMENT. IF A REDUCED PROBABILITY OF ENCOUNTERING HYDROGEN EMBRITTLEMENT IS DESIRED, AN ALTERNATE PROCESS AND / OR FINISH SHOULD BE CONSIDERED

MECHANICAL PROPERTIES - LFG 10/01/2016 REVISED

TORQUE VALUES BY DIAMETER AND MATERIAL (IN FT. LBS.)

Property Class	M3	M4	M5	M6	M8	M10	M12	M14	M16	M18	M20	M22
8.8	0.80	1.8	3.6	7	17	33	60	97	150	201	282	390
10.9	1.1	2.6	5.1	10	25	48	85	137	208	287	398	552
12.9	1.3	3.1	6.2	12	29	58	102	165	250	342	479	664

Property Class	M24	M27	M30	M33	M36	M39	M42	M45	M48	M52	M56	M60
8.8	499	746	982	1331	1717	2220	2737	3390	4095	5250	6547	8175
10.9	750	1051	1383	1875	2407	3120	3840	4762	5775	7387	9225	11475
12.9	843	1266	1657	2250	2895	3750	4638	5722	6825	9000	11280	13800

Property Class	M64	M68	M72	M76	M80	M85	M90	M95	M100	Torque Factors To be Considered
8.8	9900	12000	14250	16800	19725	24000	28350	33450	39000	Material - Property Class Are Screws Plain, Zinc Plated, Cadmium Plated, or Lubricated
10.9	13950	16950	20100	23625	27600	33225	38925	46875	54750	
12.9	17175	20100	24000	28350	33375	40125	47700	56250	66000	

**ALL SHOWN VALUES ARE ESTIMATES ONLY, THEREFORE LINDSTROM METRIC NEITHER IMPLIES OR GUARANTEES THESE VALUES
THE ONLY WAY TO DETERMINE A TRUE TORQUE VALUE IS BY ACTUAL APPLICATION**

TORQUE VALUES LFG 10/01/10 REVISED

SOCKET HEAD CAP SCREWS

Diameter ~inch	Pitch	Approximate Weight Per 100 Pieces In lbs.																																
		M1.4	M1.6	M2	M2.5	M3	M4	M5	M6	M8	M10	M12	M14	M16	M18	M20	M22	M24	M27	M30	M33	M36	M42	M48	M56	M64	M72	M80	M90	M100				
2	5/64	0.01																																
2.5	3/32	0.01	0.02																															
3	1/8	0.01	0.02	0.03																														
4	5/32	0.02	0.04	0.08																														
5	3/16	0.02	0.04	0.08	0.15																													
6	1/4	0.02	0.03	0.05	0.09	0.16	0.33																											
8	5/16	0.03	0.03	0.06	0.10	0.18	0.36	0.54																										
10	3/8	0.03	0.04	0.08	0.12	0.19	0.40	0.59	1.03																									
12	1/2	0.03	0.04	0.08	0.13	0.21	0.43	0.65	1.12	2.40																								
16	5/8		0.05	0.09	0.16	0.26	0.50	0.76	1.27	2.66	4.60																							
20	3/4			0.11	0.18	0.30	0.58	0.88	1.44	2.95	5.04	7.06																						
25	1				0.21	0.35	0.69	1.05	1.67	3.30	5.59	7.85	10.56	15.69																				
30	1-3/16				0.41	0.69	1.22	1.83	3.72	6.14	8.65	11.66	17.12	24.42	28.16																			
35	1-3/8				0.91	1.39	2.18	3.44	6.69	9.44	12.76	18.57	26.40	30.58	46.42																			
40	1-9/16				1.02	1.56	2.42	4.60	7.24	10.23	13.86	20.02	28.38	33.00	49.28	59.40																		
45	1-3/4					1.73	2.66	5.04	7.94	11.02	14.96	21.47	30.36	35.42	52.14	62.70	72.60	110																
50	2					1.90	2.90	5.48	8.65	11.99	16.06	23.32	32.34	37.84	55.00	66.00	77.44	116	139															
55	2-3/16						3.15	5.92	9.35	12.96	17.16	25.08	34.32	40.26	57.86	69.52	82.28	122	146	191														
60	2-9/16						3.39	6.36	10.05	13.95	18.48	26.84	36.30	42.68	60.72	72.60	87.12	128	154	200	301													
65	2-3/8							6.82	10.76	14.92	19.80	28.60	38.28	45.10	64.02	75.90	91.96	134	162	209	312													
70	2-3/4							7.26	11.46	15.69	21.12	30.36	40.26	47.52	67.32	79.86	96.80	140	169	218	323	449												
75	3							7.70	12.28	17.18	22.44	32.16	43.45	51.14	70.71	83.90	102	146	177	227	334	464												
80	3-3/16							8.14	12.87	17.64	23.76	33.88	44.66	53.02	73.92	87.78	106	152	183	235	348	480												
90	3-1/2							14.28	19.60	26.40	37.40	49.06	58.52	80.52	95.70	116	164	198	253	370	510													
100	4							15.66	21.56	29.04	40.92	53.46	64.02	87.12	104	126	176	213	271	394	541													
110	4-3/8							23.54	31.68	44.44	57.86	69.52	93.72	112	136	188	229	288	416	572														
120	4-3/4							25.52	34.32	47.96	62.26	75.02	100	119	146	200	244	306	440	603														
130	5							36.96	51.48	66.66	80.52	107	127	156	212	260	323	462	590															
140	5-1/2							39.60	55.00	71.06	86.02	114	135	166	224	275	341	486	664															
150	6							58.52	75.46	91.52	120	143	176	238	290	359	510	695																
160	6-5/16							62.04	79.86	97.02	127	151	186	249	306	376	532	726	1,074															
180	7							88.66	108	140	167	205	273	337	411	581	790	1,159	1,595															
200	8							119	153	183	224	297	367	447	629	851	1,243	1,705	2,189															
220	8-1/4							166	199	244	321	398	482	678	913	1,329	1,815	2,332																
240	9-1/2							215	271	345	429	495	726	975	1,412	1,925	2,486	3,146																
260	10-1/4							295	370	449	530	774	1,036	1,498	1,817	2,618	3,322	4,378	5,654															
280	11							394	480	565	623	1,098	1,584	2,147	2,772	3,476	4,598	5,918																
300	12							418	510	601	871	1,159	1,668	2,266	2,926	3,652	4,818	6,204																

ALL CALCULATIONS FOR TABLE OF WEIGHTS ARE BASED UPON VARIOUS DIN, ISO, OR ANSI PUBLICATIONS AND ARE APPROXIMATE, NOT EXACT - ALL METRIC TO INCH COMPARISONS ARE APPROXIMATE, NOT EXACT.

LFG 10/01/2016 REVISED



LOW HEAD SOCKET CAP SCREWS WITH PIN RECESS

Approximate Weight Per 100 Pieces in lbs.																			
Diameter	M4	M5	M6	M8	M10	M12	M14	M16	M18	M20	M22	M24	M27	M30	M33	M36			
~inch	8-32	10-24	1/4	5/16	3/8	1/2	9/16	5/8	11/16	3/4	7/8	1	1-1/16	1-3/16	1-5/16	1-7/16			
Pitch	0.70	0.80	1.00	1.25	1.50	1.75	2.00	2.00	2.50	2.50	2.5	3	3	3.5	3.5	4			
Length	3/8	0.29	0.48	0.79															
10	1/2	0.33	0.55	0.86	1.69														
16	5/8	0.42	0.68	0.99	1.94	3.41													
20	3/4	0.51	0.81	1.14	2.24	3.94	5.61												
25	1	0.59	0.97	1.36	2.75	4.44	6.49	9.35	12.43										
30	1-3/16	0.70	1.12	1.61	3.08	4.84	7.15	10.56	13.86	18.61	23.76								
35	1-3/8	0.75	1.28	1.83	3.45	5.61	8.03	11.66	15.33	20.53	25.96								
40	1-9/16	0.92	1.45	2.09	3.85	6.27	8.80	12.76	17.31	22.44	28.16	40.70							
50	2	1.14	1.61	2.53	4.73	7.66	10.56	15.29	20.13	26.18	33.00	47.30							
60	2-9/16	1.98	2.99	5.57	8.87	12.54	18.04	23.54	30.36	37.84	53.90	57.86							
70	2-3/4		3.45	6.40	10.12	14.30	20.35	26.84	34.54	43.12	60.50	65.56	97.90	110					
80	3-3/16			7.22	11.55	15.84	22.88	30.80	39.16	48.84	67.10	73.26	108	121	174				
90	3-1/2				12.72	17.60	25.52	33.88	43.12	53.90	73.70	81.18	118	134	189	220			
100	4					19.36	27.94	37.18	47.30	59.18	80.30	89.54	128	146	204	238			
110	4-3/8						30.58	40.26	51.70	64.24	86.90	96.58	138	158	219	255			
120	4-3/4							33.22	43.56	56.10	69.52	93.50	104	147	170	233	273		
130	5								46.64	60.50	75.24	100	112	157	182	249	290		
140	5-1/2								49.72	64.90	80.96	107	120	167	194	262	308		
150	6									69.30	86.68	113	128	177	207	275	323		
160	6-5/16										92.84	120	136	187	218	290	341		
170	6-3/4											98.56	127	143	197	231	304	359	
180	7												104	133	151	207	242	319	376
190	7-1/2													140	159	219	255	332	394
200	8													146	167	227	266	348	411

LOW HEAD SOCKET CAP SCREWS

Approximate Weight Per 100 Pieces in lbs.													
Diameter	M3	M4	M5	M6	M8	M10	M12	M14	M16	M18	M20	M22	M24
~inch	4-40	8-32	10-24	1/4	5/16	3/8	1/2	9/16	5/8	11/16	3/4	7/8	1
Pitch	0.50	0.70	0.80	1.00	1.25	1.50	1.75	2.00	2.00	2.50	2.50	2.5	3
Length	3/16	0.11											
5	1/4	0.11	0.21										
8	5/16	0.13	0.25	0.50									
10	3/8	0.15	0.28	0.55	0.79								
12	1/2	0.17	0.32	0.60	0.87	1.77							
14	9/16	0.19	0.35	0.66	0.94	1.90							
16	5/8	0.21	0.39	0.71	1.02	2.04	3.17						
18	11/16	0.24	0.43	0.76	1.10	2.17	3.39						
20	3/4	0.26	0.47	0.83	1.17	2.31	3.61	5.30					
25	1	0.58	1.00	1.42	2.64	4.18	6.09						
30	1-3/16			1.17	1.66	3.08	4.75	6.89	10.23	13.66			
35	1-3/8				1.91	3.52	5.43	7.68	11.31	15.14			
40	1-9/16				2.15	3.96	6.12	8.65	12.39	16.61	21.78	28.60	
45	1-3/4					4.40	6.80	9.61	13.71	18.08	23.54	30.80	
50	2					4.84	7.48	10.58	15.03	19.71	25.30	33.00	41.36
55	2-3/16					5.28	8.16	11.55	16.35	21.34	27.50	35.20	44.22
60	2-9/16					5.72	8.84	12.52	17.67	22.88	29.70	37.84	47.08
70	2-3/4					10.21	14.48	20.33	26.18	34.10	43.34	53.68	63.36
80	3-3/16							16.43	23.10	29.48	38.50	48.84	60.28
90	3-1/2									42.90	54.34	66.88	78.98
100	4									47.30	59.84	73.48	86.90

ALL CALCULATIONS FOR TABLE OF WEIGHTS ARE BASED UPON VARIOUS DIN, ISO, OR ANSI PUBLICATIONS AND ARE APPROXIMATE, NOT EXACT - ALL METRIC TO INCH COMPARISONS ARE APPROXIMATE, NOT EXACT.

LEF 10/01/2016 REVISED



SOCKET SET SCREWS FLAT POINT

SOCKET SET SCREWS CONE POINT

Diameter	M1.4	M1.6	M1.8	M2	M2.5	M3	M4	M5	M6	M8	M10	M12	M16	M20	M24
~inch	0-80	1-64	1-64	2-56	3-48	4-40	8-32	10-24	1/4	5/16	3/8	1/2	5/8	3/4	1
Pitch	0.30	0.35	0.35	0.40	0.45	0.50	0.70	0.80	1.00	1.25	1.50	1.75	2.00	2.50	3

Diameter	M1.4	M1.6	M1.8	M2	M2.5	M3	M4	M5	M6	M8	M10	M12	M16	M20	M24
~inch	0-80	1-64	1-64	2-56	3-48	4-40	8-32	10-24	1/4	5/16	3/8	1/2	5/8	3/4	1
Pitch	0.30	0.35	0.35	0.40	0.45	0.50	0.70	0.80	1.00	1.25	1.50	1.75	2.00	2.50	3

Length	~inch	Approximate Weight Per 100 Pieces in lbs.														
2	5/64	0.01	0.01	0.01	0.01											
2.5	3/32	0.01	0.01	0.02	0.02											
3	1/8	0.01	0.01	0.02	0.03	0.04										
4	5/32	0.01	0.01	0.02	0.03	0.05	0.07	0.09								
5	3/16	0.01	0.01	0.02	0.03	0.04	0.07	0.10	0.13	0.21						
6	1/4	0.01	0.01	0.02	0.03	0.05	0.08	0.12	0.17	0.28	0.39					
8	5/16	0.02	0.03	0.04	0.07	0.12	0.18	0.24	0.42	0.61	0.88					
10	3/8		0.03	0.05	0.09	0.15	0.23	0.32	0.55	0.83	1.19	1.87				
12	1/2			0.07	0.11	0.18	0.28	0.40	0.69	1.05	1.50	2.44	3.48			
16	5/8				0.15	0.25	0.39	0.55	0.97	1.49	2.11	3.59	5.30	6.60		
20	3/4				0.19	0.31	0.49	0.71	1.25	1.93	2.73	4.73	7.08	9.24		
25	1				0.62	0.90	1.60	2.46	3.52	6.16	9.37	12.54				
30	1-3/16				1.09	1.95	3.01	4.31	7.61	11.64	15.84					
35	1-3/8				1.29	2.29	3.56	5.10	9.04	13.90	19.14					
40	1-9/16				2.64	4.11	5.90	10.49	16.17	22.44						
45	1-3/4				4.66	6.58	11.92	18.44	25.74							
50	2				5.21	7.35	13.35	20.70	29.04							
55	2-3/16				8.10	14.81	22.88	32.34								
60	2-9/16				8.87	16.21	25.30	35.64								

Length	~inch	Approximate Weight Per 100 Pieces in lbs.														
2	5/64	0.01														
2.5	3/32	0.01														
3	1/8	0.01	0.01	0.02	0.02											
4	5/32	0.01	0.01	0.02	0.03	0.04	0.06									
5	3/16	0.01	0.01	0.02	0.03	0.04	0.06	0.08	0.11							
6	1/4	0.01	0.01	0.02	0.03	0.04	0.06	0.11	0.15	0.24						
8	5/16	0.02	0.03	0.04	0.06	0.10	0.16	0.22	0.38	0.53						
10	3/8		0.03	0.05	0.08	0.13	0.21	0.28	0.50	0.75	1.03					
12	1/2			0.07	0.10	0.16	0.26	0.36	0.59	0.97	1.34	2.13				
16	5/8				0.14	0.23	0.37	0.51	0.87	1.33	1.96	3.28	4.88			
20	3/4				0.18	0.29	0.47	0.67	1.14	1.76	2.42	4.42	6.69	8.73		
25	1				0.61	0.86	1.49	2.31	3.21	5.52	8.56	11.92				
30	1-3/16				1.06	1.84	2.86	4.00	7.02	10.01	14.89					
35	1-3/8				1.25	2.19	3.41	4.80	8.40	12.28	17.25					
40	1-9/16				2.55	3.96	5.59	9.88	14.54	20.55						
45	1-3/4				4.62	6.45	11.57	16.81	23.76							
50	2				5.17	7.22	13.00	19.07	27.06							
55	2-3/16				7.99	14.43	22.66	30.36								
60	2-9/16				8.76	15.88	24.86	33.66								

ALL CALCULATIONS FOR TABLE OF WEIGHTS ARE BASED UPON VARIOUS DIN, ISO, OR ANSI PUBLICATIONS AND ARE APPROXIMATE, NOT EXACT - ALL METRIC TO INCH COMPARISONS ARE APPROXIMATE, NOT EXACT.

LFG 10/01/2016 REVISED

11.5 - WEIGHTS - SOCKET SET SCREWS

SOCKET SET SCREWS DOG POINT

Diameter	M1.4	M1.6	M1.8	M2	M2.5	M3	M4	M5	M6	M8	M10	M12	M16	M20	M24
~inch	0-80	1-64	1-64	2-56	3-48	4-40	8-32	10-24	1/4	5/16	3/8	1/2	5/8	3/4	1
Pitch	0.30	0.35	0.35	0.40	0.45	0.50	0.70	0.80	1.00	1.25	1.50	1.75	2.00	2.50	3

SOCKET SET SCREWS CUP POINT

Diameter	M1.4	M1.6	M1.8	M2	M2.5	M3	M4	M5	M6	M8	M10	M12	M16	M20	M24
~inch	0-80	1-64	1-64	2-56	3-48	4-40	8-32	10-24	1/4	5/16	3/8	1/2	5/8	3/4	1
Pitch	0.30	0.35	0.35	0.40	0.45	0.50	0.70	0.80	1.00	1.25	1.50	1.75	2.00	2.50	3

Length	~inch	Approximate Weight Per 100 Pieces in lbs.																		
		2	2.5	3	4	5	6	8	10	12	16	20	25	30	35	40	45	50	55	60
5/64	0.01																			
3/32	0.01	0.01																		
1/8	0.01	0.01	0.01	0.02																
5/32	0.01	0.01	0.01	0.02	0.03															
3/16	0.01	0.01	0.01	0.02	0.03	0.04	0.05													
1/4	0.01	0.01	0.02	0.02	0.03	0.04	0.06	0.12												
5/16	0.02	0.03	0.04	0.06	0.10	0.16	0.22	0.37												
3/8		0.03	0.05	0.08	0.13	0.21	0.28	0.50	0.79											
1/2			0.07	0.10	0.16	0.26	0.36	0.59	0.97	1.33										
5/8				0.14	0.23	0.37	0.51	0.87	1.33	1.96	3.30									
3/4					0.18	0.29	0.47	0.67	1.14	1.76	2.42	4.42	6.23							
1						0.61	0.86	1.49	2.31	3.21	5.52	8.56	12.19							
1-3/16							1.06	1.84	2.86	4.00	7.02	10.01	14.89							
1-3/8								1.25	2.19	3.41	4.80	8.40	12.28	17.25						
1-9/16									2.55	3.96	5.59	9.88	14.54	20.55						
1-3/4										4.51	6.38	11.33	16.81	23.76						
2										5.06	7.17	12.78	19.07	27.06						
2-3/16											7.96	14.23	21.34	30.36						
2-9/16												8.76	15.69	23.54	33.66					

Length	~inch	Approximate Weight Per 100 Pieces in lbs.																		
		2	2.5	3	4	5	6	8	10	12	16	20	25	30	35	40	45	50	55	60
5/64	0.01																			
3/32	0.01	0.01	0.01	0.01	0.01	0.01														
1/8	0.01	0.01	0.01	0.01	0.02	0.02	0.03													
5/32	0.01	0.01	0.01	0.01	0.02	0.03	0.05	0.07												
3/16	0.01	0.01	0.01	0.01	0.02	0.03	0.04	0.06	0.09	0.12										
1/4	0.01	0.01	0.01	0.02	0.02	0.03	0.05	0.08	0.12	0.16	0.28									
5/16	0.02	0.03	0.04	0.07	0.12	0.17	0.24	0.41	0.60											
3/8		0.03	0.07	0.09	0.15	0.22	0.32	0.55	0.82	1.17										
1/2			0.11	0.18	0.28	0.39	0.69	1.04	1.47	2.31										
5/8				0.15	0.25	0.38	0.55	0.97	1.48	2.09	3.45	5.04								
3/4					0.19	0.31	0.27	0.70	1.25	1.92	2.71	4.60	6.84	8.84						
1						0.40	0.90	1.60	2.46	3.50	6.03	9.11	12.14							
1-3/16							1.09	1.94	3.01	4.29	7.48	11.37	15.47							
1-3/8								1.28	2.29	3.56	5.08	8.91	13.64	18.77						
1-9/16									2.64	4.11	5.87	10.36	15.91	22.00						
1-3/4										4.66	6.53	11.73	18.17	25.30						
2										5.19	7.30	13.16	20.44	28.60						
2-3/16											8.05	14.59	22.66	31.90						
2-9/16											8.82	16.02	25.08	35.20						

ALL CALCULATIONS FOR TABLE OF WEIGHTS ARE BASED UPON VARIOUS DIN, ISO, OR ANSI PUBLICATIONS AND ARE APPROXIMATE, NOT EXACT - ALL METRIC TO INCH COMPARISONS ARE APPROXIMATE, NOT EXACT.

LFG 10/01/2016 REVISED

FULL THREAD HEX HEAD CAP SCREWS

Diameter		M1.6	M2	M2.5	M3	M3.5	M4	M5	M6	M7	M8	M10	M12	M14	M16	M18	M20	M22	M24	M27	M30	M33	M36	M39	M42	M45	M48	M52	
Pitch		0.35	0.4	0.45	0.5	0.6	0.7	0.8	1	1.00	1.25	1.5	1.75	2	2	2.5	2.5	2.5	3	3	3.5	3.5	4	4	4.5	4.5	5	5	
Length -inch		0.02	0.02	0.04	0.08																								
2	5/64																												
3	1/8	0.02	0.04	0.08																									
4	5/32	0.03	0.05	0.09	0.11																								
5	3/16	0.03	0.05	0.09	0.12	0.18	0.28																						
6	1/4	0.03	0.06	0.10	0.13	0.20	0.29	0.48	0.75																				
7	1/4	0.03	0.06	0.11	0.13	0.21	0.31	0.50	0.79	1.23																			
8	5/16	0.04	0.06	0.11	0.15	0.22	0.33	0.52	0.82	1.29	1.87	3.34																	
10	3/8	0.04	0.07	0.13	0.17	0.25	0.36	0.58	0.90	1.40	2.00	3.56	5.13	8.36															
12	1/2	0.04	0.08	0.14	0.18	0.28	0.40	0.63	0.97	1.51	2.16	3.78	5.50	8.80	11.64														
14	9/16		0.09	0.15	0.20	0.30	0.43	0.69	1.05	1.62	2.31	4.00	5.81	9.24	12.23														
16	5/8		0.09	0.17	0.22	0.33	0.46	0.74	1.12	1.73	2.44	4.22	6.09	9.68	12.83	18.04	23.10	29.26	38.06										
18	11/16		0.18	0.24	0.35	0.50	0.80	1.20	1.84	2.57	4.44	7.46	10.56	13.97	19.18	25.08	31.46	40.48											
20	3/4		0.19	0.26	0.38	0.53	0.85	1.28	1.95	2.71	4.66	8.82	10.56	13.97	19.18	25.08	31.46	40.48											
22	7/8		0.21	0.28	0.41	0.56	0.91	1.35	2.06	2.84	4.88	7.26	11.00	14.56	20.28	26.18	32.56	41.80	59.18										
25	1		0.22	0.31	0.45	0.62	0.99	1.46	2.20	3.06	5.21	7.50	11.66	15.44	21.08	27.28	34.10	43.78	61.60										
28	1-1/8		0.33	0.49	0.67	1.07	1.57	2.35	3.28	5.54	7.96	12.30	16.32	22.00	28.38	35.42	44.00	64.24											
30	1-3/16		0.35	0.51	0.70	1.12	1.65	2.49	3.41	5.76	8.29	12.74	16.92	22.88	29.48	36.96	47.08	68.20											
35	1-3/8					0.58	0.79	1.26	1.84	2.75	3.76	6.31	9.09	13.84	18.37	24.64	31.90	39.82	50.38	70.18	93	119	147	191					
40	1-9/16					0.87	1.40	2.03	3.04	4.11	6.86	9.88	14.94	19.84	26.40	34.10	42.46	53.68	74.36	99	126	157	200	240	293	350			
45	1-3/4					0.95	1.54	2.22	3.30	4.47	7.41	10.67	16.04	21.36	28.16	36.30	45.32	56.98	78.76	104	132	165	209	249	304	363			
50	2					1.03	1.67	2.42	3.59	4.80	7.96	11.44	17.14	22.66	29.92	38.72	48.18	60.28	82.94	109	139	172	218	260	315	376	460		
55	2-3/16					1.13	1.81	2.62	3.85	5.15	8.51	12.23	18.22	24.20	31.90	40.92	51.04	63.58	87.34	114	145	180	227	271	328	389	477		
60	2-9/16					1.21	1.90	2.79	4.11	5.50	9.09	12.80	19.32	25.74	33.66	43.12	53.68	66.88	91.52	119	151	187	235	279	339	403	493		
65	2-3/8					1.30	2.08	2.99	4.40	5.85	9.64	13.82	20.42	27.06	35.42	45.54	56.54	70.18	95.70	125	158	195	244	288	352	416	508		
70	2-3/4					1.38	2.22	3.17	4.66	6.20	10.19	14.61	21.54	28.60	37.18	47.74	59.18	73.48	99.88	130	164	200	255	301	363	429	526		
75	3					2.35	3.37	4.95	6.56	10.74	15.40	22.44	30.14	38.94	49.94	62.04	76.56	104	135	171	209	264	310	376	442	541			
80	3-3/16					2.49	3.56	5.21	6.91	11.29	16.19	23.54	31.68	40.92	52.36	64.90	79.86	108	140	177	218	273	321	387	458	559			
85	3-3/8							5.50	7.26	11.84	16.98	24.64	33.00	42.68	54.34	67.76	83.16	113	145	184	224	282	330	398	471	574			
90	3-1/2							5.76	7.61	12.39	17.78	25.74	34.54	44.44	56.76	70.62	86.46	117	151	191	233	290	341	411	484	590			
95	3-3/4							6.05	7.74	13.16	18.57	26.84	36.08	46.20	58.96	73.26	89.76	121	156	196	242	299	352	422	497	605			
100	4							6.31	8.29	13.49	19.36	27.94	37.40	47.96	61.38	76.12	93.06	125	161	202	251	308	363	436	510	623			
110	4-3/8							9.00	14.61	20.94	30.14	40.48	51.70	66.00	81.62	99.66	134	171	215	264	326	383	460	539	653				
120	4-3/4										32.34	43.34	55.22	70.40	87.34	106	142	182	229	277	343	405	482	565	686				
130	5										15.71	22.44	32.34	43.34	55.22	70.40	87.34	106	142	182	229	277	343	405	482	565	686		
140	5-1/2										16.81	23.98	34.54	46.20	58.96	74.80	92.62	113	151	192	240	293	363	425	506	592	717		
150	6										17.91	25.52	36.74	49.28	62.48	79.42	98.56	119	159	203	253	308	381	444	530	620	750		
160	6-5/16										19.01	27.06	38.94	52.14	66.00	83.82	104	126	168	213	266	323	398	466	554	647	781		
170	6-11/16																												
180	7																												
190	7-1/2																												
200	8																												

Approximate Weight Per 100 Pieces In lbs.

ALL CALCULATIONS FOR TABLE OF WEIGHTS ARE BASED UPON VARIOUS DIN, ISO, OR ANSI PUBLICATIONS AND ARE APPROXIMATE, NOT EXACT - ALL METRIC TO INCH COMPARISONS ARE APPROXIMATE, NOT EXACT.

LFG 10/01/2016 REVISED

11.6 - WEIGHTS - FULL THREAD HEX CAP SCREWS

PARTIAL THREAD HEX HEAD CAP SCREWS

Diameter		M1.6	M2	M2.5	M3	M3.5	M4	M4.5	M5	M6	M7	M8	M10	M12	M14	M16	M18	M20	M22	M24	M27	M30	M33	M36	M39	M42	M45	M48	M52		
Pitch		0.35	0.4	0.45	0.5	0.6	0.7	0.8	1	1.00	1.25	1.5	1.75	2	2	2.5	2.5	3	3	3	3	3.5	3.5	4	4	4.5	4.5	5	5		
Length		Approximate Weight Per 100 Pieces in lbs.																													
12	1/2	0.05																													
14	9/16	0.06																													
16	5/8	0.07																													
18	11/16		0.11	0.19																											
20	3/4		0.12	0.20																											
22	7/8		0.13	0.22	0.28																										
25	1		0.24	0.31																											
28	1-1/8		0.26	0.35	0.50	0.69	1.07																								
30	1-3/16		0.38	0.55	0.73	1.16																									
35	1-3/8		0.41	0.59	0.79	1.24	1.33	2.79																							
40	1-9/16				0.64	0.89	1.41	2.01	2.99	3.56																					
45	1-3/4				1.00				1.58	2.24	3.32	4.47	7.70																		
50	2					1.76	2.49	3.65	4.88	8.36	11.79																				
55	2-3/16					1.93	2.71	3.98	5.32	9.04	12.78	18.04																			
60	2-9/16						2.95	4.29	5.68	9.64	13.77	19.38	25.30																		
65	2-3/8						3.17	4.62	6.12	10.32	14.74	20.70	27.06																		
70	2-3/4							4.95	6.51	11.00	15.47	21.74	28.82	37.62	48.18																
75	3							5.28	7.00	11.68	16.43	23.10	30.58	39.82	50.82	61.82															
80	3-3/16								7.41	12.36	17.40	24.42	32.34	42.02	53.46	65.12															
85	3-3/8								7.85	13.05	18.39	25.74	34.10	44.00	56.10	68.42	86.24														
90	3-1/2									13.73	19.38	27.06	35.86	46.20	58.74	71.72	90.20														
95	3-3/4									14.41	20.33	27.94	37.62	48.40	61.38	75.02	94.16	123	157												
100	4									15.09	21.30	29.26	39.38	50.60	64.02	78.32	98.12	128	163												
110	4-3/8									15.77	22.22	30.58	40.92	52.80	66.66	81.40	102	133	169	209											
120	4-3/4									23.98	33.22	44.44	57.20	71.94	88.00	110	143	181	224	273											
130	5									25.96	36.08	47.96	61.60	77.22	94.60	118	153	194	240	290	332										
140	5-1/2									38.28	50.60	65.12	82.28	99.00	123	158	202	253	306	348	436	517									
150	6									40.70	54.12	69.52	87.56	106	131	168	215	268	323	365	460	546	629								
160	6-5/16									57.64	73.92	92.84	112	139	178	227	284	341	383	484	572	662	794								
170	6-11/16									61.16	78.32	98.12	119	146	186	239	297	359	403	508	601	695	829								
180	7									82.72	103	125	154	198	251	310	376	422	530	627	726	865									
190	7-1/2									87.12	109	132	162	208	264	326	394	442	554	656	757	902									
200	8									114	139	169	218	275	339	411	462	579	682	788	939										
220	8-1/4									120	145	177	227	288	354	429	484	603	708	818	975										
240	9-1/2									158	191	249	312	385	464	530	651	763	882	1,047											
260	10-1/4									206	268	337	414	499	572	700	818	944	1,124												
280	11									288	361	444	535	636	748	876	1,005	1,199													
300	12									385	473	570	662	774	933	1,067	1,276														
										409	504	605	706	801	990	1,129	1,351														

ALL CALCULATIONS FOR TABLE OF WEIGHTS ARE BASED UPON VARIOUS DIN, ISO, OR ANSI PUBLICATIONS AND ARE APPROXIMATE, NOT EXACT - ALL METRIC TO INCH COMPARISONS ARE APPROXIMATE, NOT EXACT.

LEG 10/01/2016 REVISED



**CARRIAGE BOLTS
NO NUTS**

Diameter ~inch	Approximate Weight Per 100 Pieces in lbs.									
	M5 10-24 0.8	M6 1/4 1	M8 5/16 1.25	M10 3/8 1.5	M12 1/2 1.75	M16 5/8 2	M20 3/4 2.5			
16	0.88	1.52								
20	0.99	1.67	3.04	4.99						
25	1.12	1.87	3.39	5.54						
30	1.30	2.11	3.74	6.09	10.05					
35	1.47	2.35	4.18	6.64	10.87					
40	1.65	2.60	4.62	7.19	11.68					
45	1.83	2.84	5.06	7.88	12.50					
50	2.00	3.08	5.50	8.56	13.46	26.18				
55	2.18	3.32	5.92	9.24	14.43	27.72				
60	2.35	3.56	6.36	9.92	15.40	29.26				
65	2.53	3.81	6.80	10.60	16.37	31.02				
70	2.71	4.05	7.24	11.29	17.34	32.78	54.34			
75	2.88	4.29	7.68	11.97	18.30	34.54	57.20			
80	3.06	4.53	8.10	12.65	19.14	36.30	59.84			
90	3.12	5.02	8.98	14.01	21.12	39.82	65.34			
100	4	5.50	9.86	15.38	23.10	43.34	70.84			
110	4-3/8	5.98	10.74	16.74	25.08	46.86	76.34			
120	4-3/4	6.47	11.62	18.11	27.06	50.38	81.84			
130	5	6.95	12.50	19.47	29.04	53.90	87.34			
140	5-1/2	7.22	13.38	20.90	31.02	57.42	92.84			
150	6	7.70	14.26	22.22	33.00	60.94	98.34			
160	6-5/16			23.54	34.98	64.46	109			
180	7			26.18	38.94	71.50	120			
200	8			28.82	42.90	78.54	131			

**FLANGE
BOLTS**

Diameter ~inch	Approximate Weight Per 100 Pieces in lbs.									
	M5 10-24 0.8	M6 1/4 1	M8 5/16 1.25	M10 3/8 1.5	M12 1/2 1.75	M14 9/16 2	M16 5/8 2	M20 3/4 2.5		
16	1.56	3.44	5.40							
20	1.80	3.60	5.80	8.80						
25	2.10	3.80	6.30	9.60						
30	2.40	4.00	6.80	10.40						
35	2.70	4.20	7.30	11.20	14.18	21.00				
40	3.00	4.40	7.80	12.00	15.50	22.76				
45	3.30	4.60	8.30	12.80	16.82	24.52				
50	3.60	4.80	8.80	13.60	18.14	26.28				
55	5.00	9.30								
60	5.20	9.80	15.20			29.80				
65		10.30								
70	5.60	10.80	16.80			33.32				
75	5.80									
80	6.00	11.80	18.40			36.84				
90	6.40	12.80	20.00							
100	6.80	13.80	21.60			43.88				

**LIFTING EYE
BOLTS** **LIFTING EYE
NUTS** **THREADED
ROD** **1M LENGTH**

Diameter	~inch	Approximate Weight Per 100 Pieces in lbs.
M2	2-5/8	4.11
M2.5	3-4/8	6.62
M3	4-4/0	9.72
M4	8-3/2	17.23
M5	10-2/4	27.32
M6	1/4	13.2
M7	1/4	11.0
M8	5/16	13.2
M10	3/8	24.2
M12	1/2	39.6
M14	9/16	50.8
M16	5/8	61.6
M18	11/16	364
M20	3/4	99
M22	7/8	143
M24	1	163
M27	1-1/16	209
M30	1-3/16	365
M33	1-5/16	374
M36	1-7/16	583
M39	1-9/16	887
M42	1-5/8	887
M45	1-3/4	983
M48	1-7/8	1,404
M52	2	1,525
M64	2-9/16	2,728
M72	2-7/8	5,128
M80	3-3/16	7,524
M100	4	10,802

ALL CALCULATIONS FOR TABLE OF WEIGHTS ARE BASED UPON VARIOUS DIN, ISO, OR ANSI PUBLICATIONS AND ARE APPROXIMATE, NOT EXACT - ALL METRIC TO INCH COMPARISONS ARE APPROXIMATE, NOT EXACT.

LFG 10/01/2016 REVISED

11.9 - WEIGHTS - NUTS AND WASHERS

HEX NUTS

Nut Style	Approximate Weight Per 100 Pieces in lbs.									
	~inch Diameter	Full Hex Nuts	Hex Jam Nuts	Nylon Insert Hex Nuts	All Metal Hex Lock Nuts	Hex Nuts With Washers	Hex Flange Nuts	Square Weld Nuts	Hex Weld Nuts	Hex Weld Nuts
M1	000-120	0.01								
M1.2	00-90	0.01								
M1.4	0-80	0.01								
M1.6	1-64	0.02	0.01							
M1.7										
M1.8	1-64	0.02	0.02							
M2	2-56	0.03	0.02							
M2.2	2-56	0.04	0.03							
M2.3										
M2.5	3-48	0.06	0.05							
M2.6	3-48									
M3	4-40	0.08	0.06	0.11		0.09				
M3.5	6-32	0.11	0.08	0.17					0.17	
M4	8-32	0.18	0.13	0.22	0.22	0.21		0.18	0.25	
M5	10-24	0.27	0.18	0.31	0.28	0.33		0.37	0.38	
M6	1/4	0.55	0.35	0.53	0.55	0.63	1.00	0.53	0.55	
M7	1/4	0.69		0.66				0.67	0.72	
M8	5/16	1.14	0.70	1.20	1.30	1.30	1.65	1.43	1.16	
M10	3/8	2.55	1.58	2.33	2.73	2.83	3.98	2.49	2.11	
M12	1/2	3.81	2.29	3.78	3.80		6.27	3.66	3.02	
M14	9/16	5.50	3.50	5.72	6.08		12.12	5.89	4.7	
M16	5/8	7.33	4.51	7.48	7.81		22.13	7.89	6.28	
M18	11/16	10.87	6.51	9.90	10.72					
M20	3/4	14.17	8.84	14.30	14.85					
M22	7/8	17.38	10.63	16.50	17.97					
M24	1	24.20	19.69	22.00	25.48		39.73			
M27	1-1/16	36.30	22.22	35.64	35.04					
M30	1-3/16	49.06	30.58	46.64	50.05					
M33	1-5/16	63.36	40.26	69.74						
M36	1-7/16	86.46	53.68	91.30	85.10					
M39	1-9/16	110	69.52	110						
M42	1-5/8	143	88.66	138						
M45	1-3/4	176	110	170						
M48	1-7/8	215	136	220						
M52	2	268	166							
M56	2-3/16	312								
M60	2-3/8	372								
M64	2-9/16	436								
M72	2-7/8	587								
M80	3-3/16	757								
M90	3-9/16	1,085								
M100	4	1,500								

FLAT AND LOCK WASHERS

Washer Style	Screw Diameter	Approximate Weight per 100 pieces in lbs.													
		~inch	Flat Washers Regular	Flat Washers Small	Fender Washers	Split Lock Washers	Split High Collar Lock Washers	External Tooth Washers	Internal Tooth Washers	External Internal Tooth Serrated Washers	External Tooth Serrated Washers				
1 mm	000-120		0.01												
1.2 mm	00-90		0.01												
1.4 mm	0-80		0.01												
1.6 mm	1-64		0.01							0.01					
1.7 mm			0.01									0.01			
1.8 mm	1-64		0.01												
2 mm	2-56		0.01							0.01					0.01
2.2 mm	2-56														
2.3 mm			0.02							0.01					
2.5 mm	3-48		0.02	0.01		0.06				0.01					0.01
2.6 mm	3-48		0.03												
3 mm	4-40		0.03	0.02		0.08				0.02					0.01
3.5 mm	6-32		0.03	0.02		0.12				0.03					0.02
4 mm	8-32		0.07	0.03		0.17				0.04					0.02
5 mm	10-24		0.10	0.07		0.32				0.08					0.04
6 mm	1/4		0.22	0.17		0.81				0.18					0.07
7 mm	1/4		0.31			1.16				0.20					0.11
8 mm	5/16		0.40	0.33		1.37				0.35					0.18
10 mm	3/8		0.79	0.46		2.88				0.56					0.28
12 mm	1/2		1.38	0.63		4.88				0.80					0.33
14 mm	9/16		1.90	1.19		6.95				1.32					0.42
16 mm	5/8		2.49	1.88		9.00				1.96					0.51
18 mm	11/16		3.23	2.30		14.83				2.14					0.64
20 mm	3/4		3.78	2.90		16.90				3.54					0.81
22 mm	7/8		4.03							3.63					1.32
24 mm	1		7.11	4.86		30.58				2.99					1.65
27 mm	1-1/16		9.31							6.31					1.76
30 mm	1-3/16		11.79	8.36		60.06				9.75					2.64
33 mm	1-5/16		16.57							12.28					3.08
36 mm	1-7/16		20.26	13.53		115				14.81					
39 mm	1-9/16		29.26							15.77					
42 mm	1-5/8		40.26							24.42					
45 mm	1-3/4		48.40							25.74					
48 mm	1-7/8		64.68							27.06					
52 mm	2		72.60							40.04					
56 mm	2-3/16		93.50							42.46					
60 mm	2-3/8		101							44.66					
64 mm	2-9/16		108							47.96					
72 mm	2-7/8		138							52.80					
80 mm	3-3/16		210							57.64					
90 mm	3-9/16		275							63.80					
100 mm	4		376							69.96					

ALL CALCULATIONS FOR TABLE OF WEIGHTS ARE BASED UPON VARIOUS DIN, ISO, OR ANSI PUBLICATIONS AND ARE APPROXIMATE, NOT EXACT - ALL METRIC TO INCH COMPARISONS ARE APPROXIMATE, NOT EXACT.

LFG 10/01/2016 REVISED



Get quote >>

SLOTTED CHEESE HEAD MACHINE SCREWS

Diameter	M1	M1.2	M1.4	M1.6	M1.8	M2	M2.3	M2.5	M2.6	M3	M3.5	M4	M5	M6	M8	M10
-inch	000-120	00-90	0-80	1-64	1-64	2-56	3-48	3-48	3-48	4-40	6-32	8-32	10-24	1/4	5/16	3/8
Pitch	0.25	0.25	0.3	0.35	0.35	0.4	0.45	0.45	0.45	0.5	0.6	0.7	0.8	1	1.25	1.5

Length	-inch	Approximate Weight Per 100 Pieces In lbs.															
2	5/64	0.01	0.01	0.01	0.02	0.02											
2.5	3/48																
3	1/8	0.01	0.01	0.01	0.02	0.03	0.04	0.06									
4	5/32	0.01	0.01	0.02	0.21	0.03	0.04	0.07	0.11								
5	5/16	0.01	0.01	0.02	0.02	0.03	0.04	0.07	0.12	0.17	0.24						
6	1/4	0.01	0.01	0.02	0.03	0.04	0.05	0.08	0.13	0.19	0.26	0.45					
8	5/16	0.01	0.02	0.02	0.03	0.04	0.06	0.09	0.15	0.21	0.29	0.51	0.78				
10	3/8	0.01	0.02	0.03	0.04	0.05	0.06	0.11	0.17	0.24	0.32	0.56	0.86	1.73			
12	1/2		0.02	0.03	0.04	0.06	0.07	0.12	0.19	0.26	0.36	0.62	0.94	1.87	3.21		
14	9/16			0.04	0.05	0.06	0.08	0.13	0.21	0.29	0.39	0.67	1.02	2.01	3.43		
16	5/8				0.05	0.07	0.09	0.15	0.23	0.32	0.43	0.73	1.10	2.15	3.65		
18	11/16					0.08	0.10	0.16	0.25	0.34	0.46	0.78	1.17	2.29	3.87		
20	3/4							0.11	0.27	0.37	0.50	0.83	1.25	2.42	4.09		
22	7/8							0.19	0.29	0.40	0.53	0.88	1.33	2.57	4.31		
25	1							0.21	0.32	0.44	0.58	0.97	1.44	2.77	4.64		
28	1-1/8								0.35	0.48	0.63	1.03	1.56	2.99	4.97		
30	1-3/16								0.37	0.50	0.66	1.10	1.64	3.12	5.19		
35	1-3/8								0.57	0.75	1.24	1.82	3.48	5.74			
40	1-9/16								0.84	1.38	2.02	3.83	6.29				
45	1-3/4								1.51	2.20	4.16	6.84					
50	2								1.65	2.40	4.53	7.39					
55	2-3/16											2.60	4.86	7.94			
60	2-3/8											2.79	5.21	8.49			
65	2-9/16												5.54	9.04			
70	2-3/4												5.90	9.59			
75	3												6.23	10.14			
80	3-3/16													10.69			

SLOTTED PAN HEAD MACHINE SCREWS

Diameter	M1	M1.2	M1.4	M1.6	M1.8	M2	M2.3	M2.5	M2.6	M3	M3.5	M4	M5	M6	M8	M10
-inch			0-80	1-64	1-64	2-56	3-48	3-48	3-48	4-40	6-32	8-32	10-24	1/4	5/16	3/8
Pitch	0.25	0.25	0.3	0.35	0.35	0.4	0.45	0.45	0.45	0.5	0.6	0.7	0.8	1	1.25	1.5

Length	-inch	Approximate Weight Per 100 Pieces In lbs.															
2	5/64				0.02												
2.5	3/48				0.02			0.03									
3	1/8				0.02			0.04									
4	5/32				0.02			0.04		0.11							
5	5/16				0.02			0.04		0.08		0.12	0.18	0.26			
6	1/4				0.03			0.05		0.08		0.13	0.19	0.27	0.50		
8	5/16				0.03			0.06		0.09		0.15	0.22	0.31	0.55	0.88	
10	3/8				0.04			0.06		0.11		0.17	0.25	0.34	0.61	0.96	2.06
12	1/2				0.04			0.07		0.12		0.19	0.27	0.37	0.66	1.04	2.20
14	9/16				0.05			0.08		0.13		0.21	0.30	0.41	0.72	1.12	2.33
16	5/8				0.05			0.09		0.15		0.23	0.33	0.44	0.77	1.20	2.46
18	11/16							0.16		0.25		0.35	0.48	0.83	1.27	2.62	4.66
20	3/4							0.17		0.27		0.38	0.51	0.88	1.35	2.77	4.88
22	7/8							0.18		0.29		0.40	0.55	0.94	1.43	2.90	5.10
25	1							0.21		0.31		0.44	0.60	1.02	1.54	3.10	5.43
28	1-1/8									0.34		0.48	0.65	1.10	1.66	3.30	5.76
30	1-3/16									0.36		0.51	0.68	1.15	1.74	3.45	5.98
35	1-3/8									0.58		0.77	1.29	1.93	3.81	6.53	
40	1-9/16									0.85		1.43	2.13	4.16	7.08		
45	1-3/4									1.56		2.31	4.51	8.18			
50	2									1.70		2.51	4.86	8.73			
55	2-3/16											2.71	5.21	9.28			
60	2-3/8											2.90	5.57	9.28			
65	2-9/16											5.92	9.83				
70	2-3/4											6.27	10.38				
75	3											6.62	10.93				
80	3-3/16											6.97	11.48				

ALL CALCULATIONS FOR TABLE OF WEIGHTS ARE BASED UPON VARIOUS DIN, ISO, OR ANSI PUBLICATIONS AND ARE APPROXIMATE, NOT EXACT - ALL METRIC TO INCH COMPARISONS ARE APPROXIMATE, NOT EXACT.

LFG 10/01/2016 REVISED

SLOTTED OVAL HEAD MACHINE SCREWS

SLOTTED FLAT HEAD MACHINE SCREWS

Diameter	M1	M1.2	M1.4	M1.6	M1.8	M2	M2.3	M2.5	M2.6	M3	M3.5	M4	M5	M6	M8	M10
-inch	000-120	00-90	0-80	1-64	1-64	2-56		3-48	3-48	4-40	6-32	8-32	10-24	1/4	5/16	3/8
Pitch	0.25	0.25	0.3	0.35	0.35	0.4	0.45	0.45	0.45	0.5	0.6	0.7	0.8	1	1.25	1.5

Diameter	M1	M1.2	M1.4	M1.6	M1.8	M2	M2.3	M2.5	M2.6	M3	M3.5	M4	M5	M6	M8	M10
-inch	000-120	00-90	0-80	1-64	1-64	2-56		3-48	3-48	4-40	6-32	8-32	10-24	1/4	5/16	3/8
Pitch	0.25	0.25	0.3	0.35	0.35	0.4	0.45	0.45	0.45	0.5	0.6	0.7	0.8	1	1.25	1.5

Length	-inch	Approximate Weight Per 100 Pieces in lbs.															
		2	5/64	0.01	0.01	0.01	0.01	0.01	0.01	0.01	0.01	0.01	0.01	0.01	0.01	0.01	0.01
2.5	3/48																
3	1/8	0.01	0.01	0.01	0.01	0.01	0.01	0.01	0.01	0.01	0.01	0.01	0.01	0.01	0.01	0.01	0.01
4	5/32	0.01	0.01	0.01	0.02	0.03	0.03	0.05	0.05	0.08	0.12						
5	3/16	0.01	0.01	0.01	0.02	0.03	0.03	0.06	0.06	0.09	0.13	0.14					
6	1/4	0.01	0.01	0.02	0.02	0.04	0.04	0.07	0.07	0.10	0.14	0.20	0.33				
8	5/16			0.02	0.03	0.05	0.05	0.08	0.08	0.12	0.17	0.23	0.38	0.59			
10	3/8			0.02	0.03	0.05	0.05	0.09	0.09	0.14	0.20	0.27	0.44	0.66	1.35		
12	1/2				0.04	0.06	0.06	0.10	0.10	0.15	0.22	0.30	0.49	0.74	1.49	2.57	
14	9/16				0.04	0.07	0.07	0.12	0.12	0.17	0.25	0.33	0.54	0.82	1.63	2.79	
16	5/8				0.05	0.08	0.08	0.13	0.13	0.18	0.28	0.37	0.60	0.90	1.77	3.01	
18	11/16				0.00	0.09	0.09	0.15	0.15	0.21	0.30	0.36	0.65	0.97	1.91	3.23	
20	3/4					0.10	0.10	0.16	0.16	0.23	0.33	0.44	0.71	1.05	2.05	3.45	
22	7/8					0.17	0.17	0.25	0.25	0.35	0.47	0.76	1.13	2.19	3.67		
25	1					0.15	0.15	0.28	0.28	0.39	0.52	0.80	1.25	2.40	4.00		
28	1-1/8					0.31	0.31	0.43	0.43	0.57	0.90	1.36	2.60	4.33			
30	1-3/16					0.33	0.33	0.46	0.46	0.61	0.98	1.44	2.75	4.55			
35	1-3/8					0.53	0.53	0.69	0.69	1.08	1.63	3.10	5.21				
40	1-9/16					0.78	0.78	1.25	1.25	1.83	3.45	5.65					
45	1-3/4					1.41	1.41	2.02	2.02	3.81	6.20						
50	2					1.58	1.58	2.22	2.22	4.16	6.75						
55	2-3/16					2.42	2.42	4.51	4.51	7.30							
60	2-3/8					2.62	2.62	5.04	5.04	7.88							
65	2-9/16					5.39	5.39	8.40	8.40								
70	2-3/4					5.74	5.74	8.98	8.98								
75	3					6.09	6.09	9.53	9.53								
80	3-3/16					6.45	6.45	10.08	10.08								

Length	-inch	Approximate Weight Per 100 Pieces in lbs.															
		2	5/64	0.01	0.01	0.01	0.01	0.01	0.01	0.01	0.01	0.01	0.01	0.01	0.01	0.01	0.01
2.5	3/48																
3	1/8	0.02	0.04														
4	5/32	0.01	0.05	0.06	0.10												
5	3/16	0.01	0.05	0.07	0.11	0.15											
6	1/4	0.01	0.06	0.08	0.12	0.17	0.27										
8	5/16		0.07	0.10	0.15	0.20	0.32	0.48									
10	3/8		0.08	0.12	0.17	0.23	0.37	0.56	1.11								
12	1/2		0.06	0.10	0.14	0.20	0.27	0.43	0.64	1.25	2.11						
14	9/16		0.07	0.11	0.16	0.23	0.30	0.48	0.72	1.39	2.33						
16	5/8		0.08	0.12	0.18	0.25	0.34	0.54	0.79	1.53	2.55						
18	11/16		0.08	0.14	0.20	0.28	0.37	0.59	0.87	1.67	2.77						
20	3/4		0.09	0.15	0.22	0.31	0.40	0.65	0.95	1.37	2.99						
22	7/8		0.16	0.24	0.33	0.44	0.70	1.03	1.94	3.21							
25	1		0.18	0.27	0.37	0.49	0.78	1.14	2.15	3.54							
28	1-1/8			0.30	0.41	0.54	0.86	1.26	2.35	3.87							
30	1-3/16			0.32	0.44	0.57	0.92	1.34	2.51	4.09							
35	1-3/8			0.50	0.66	1.05	1.53	2.86	4.64								
40	1-9/16			0.74	1.19	1.72	3.21	5.19									
45	1-3/4			1.32	1.92	3.56	5.74										
50	2			1.46	2.11	3.92	6.29										
55	2-3/16			2.33	4.27	6.84											
60	2-3/8			2.53	4.77	7.41											
65	2-9/16			5.13	7.95												
70	2-3/4			5.48	8.12												
75	3			5.83	9.11												
80	3-3/16			6.18	9.66												

ALL CALCULATIONS FOR TABLE OF WEIGHTS ARE BASED UPON VARIOUS DIN, ISO, OR ANSI PUBLICATIONS AND ARE APPROXIMATE, NOT EXACT - ALL METRIC TO INCH COMPARISONS ARE APPROXIMATE, NOT EXACT.

LFG 10/01/2016 REVISED



BY ANY MEASURE.

Inch Products

INCH PRODUCTS

THE DISTRIBUTOR'S CHOICE WITH THE INDUSTRY'S WIDEST AND DEEPEST



Get quote >>

STANDARD

Angic Global Solutions

1-888-872-0690

<https://www.AngicGlobal.com> Sales@AngicGlobal.com

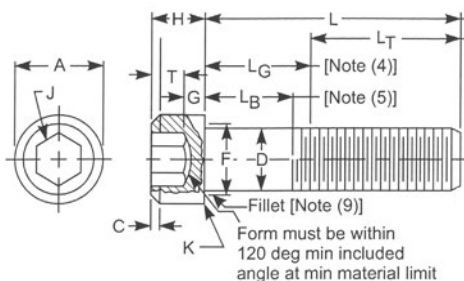

For Screws Not Fully Threaded, The Thread Length Shown Is Minimum

12.1 - INCH SOCKET HEX CAP SCREWS

Thread Size	# 0		# 1		# 2		# 3		# 4		# 5		# 6	
Thread Length LT	0.50		0.62		0.62		0.62		0.75		0.75		0.75	
Body Diameter D	min.	max.	min.	max.	min.	max.	min.	max.	min.	max.	min.	max.	min.	max.
	0.0568	0.0600	0.0695	0.0730	0.0822	0.0860	0.0949	0.0990	0.1075	0.1120	0.1202	0.1250	0.1329	0.1380
Head Dia. A	min.	max.	min.	max.	min.	max.	min.	max.	min.	max.	min.	max.	min.	max.
	0.091	0.096	0.112	0.118	0.134	0.140	0.154	0.161	0.176	0.183	0.198	0.205	0.218	0.226
Head Height H	min.	max.	min.	max.	min.	max.	min.	max.	min.	max.	min.	max.	min.	max.
	0.057	0.060	0.070	0.073	0.083	0.086	0.095	0.099	0.108	0.112	0.121	0.125	0.134	0.138
Key Size nominal J	0.050		1/16 (0.062)		5/64 (0.078)		5/64 (0.078)		3/32 (0.094)		3/32 (0.094)		7/64 (0.109)	
Key Engagement T	min.		min.		min.		min.		min.		min.		min.	
	0.025		0.031		0.038		0.044		0.051		0.057		0.064	

Thread Size	# 8		# 10		1/4		5/16		3/8		7/16		1/2	
Thread Length LT	0.88		0.88		1.00		1.12		1.25		1.38		1.50	
Body Diameter D	min.	max.	min.	max.	min.	max.	min.	max.	min.	max.	min.	max.	min.	max.
	0.1585	0.1640	0.1840	0.1900	0.2435	0.2500	0.3053	0.3125	0.3678	0.3750	0.4294	0.4375	0.4919	0.5000
Head Dia. A	min.	max.	min.	max.	min.	max.	min.	max.	min.	max.	min.	max.	min.	max.
	0.262	0.270	0.303	0.312	0.365	0.375	0.457	0.469	0.550	0.562	0.642	0.656	0.735	0.750
Head Height H	min.	max.	min.	max.	min.	max.	min.	max.	min.	max.	min.	max.	min.	max.
	0.159	0.164	0.185	0.190	0.244	0.250	0.306	0.312	0.368	0.375	0.430	0.438	0.492	0.500
Key Size nominal J	9/64 (0.414)		5/32 (0.156)		3/16 (0.188)		1/4 (0.250)		5/16 (0.312)		3/8 (0.375)		3/8 (0.375)	
Key Engagement T	min.		min.		min.		min.		min.		min.		min.	
	0.077		0.090		0.120		0.151		0.182		0.213		0.245	

Thread Size d1	5/8		3/4		7/8		1		1-1/8		1-1/4		1-3/8	
Thread Length LT	1.75		2.00		2.25		2.50		2.81		3.12		3.44	
Body Diameter D	min.	max.	min.	max.	min.	max.	min.	max.	min.	max.	min.	max.	min.	max.
	0.6163	0.6250	0.7406	0.7500	0.8647	0.8750	0.9886	1.0000	1.1086	1.1250	1.2336	1.2500	1.3568	1.3750
Head Dia. A	min.	max.	min.	max.	min.	max.	min.	max.	min.	max.	min.	max.	min.	max.
	0.921	0.938	1.107	1.125	1.293	1.312	1.479	1.500	1.665	1.688	1.852	1.875	2.038	2.062
Head Height H	min.	max.	min.	max.	min.	max.	min.	max.	min.	max.	min.	max.	min.	max.
	0.616	0.625	0.740	0.750	0.864	0.875	0.988	1.000	1.111	1.125	1.236	1.250	1.360	1.375
Key Size nominal J	1/2 (0.500)		5/8 (0.625)		3/4 (0.750)		3/4 (0.750)		7/8 (0.875)		7/8 (0.875)		1 (1.000)	
Key Engagement T	min.		min.		min.		min.		min.		min.		min.	
	.307		0.370		0.432		0.495		0.557		0.620		0.682	

Thread Size d1	1-1/2		1-3/4		2		2-1/4		2-1/2		2-3/4		3	
Thread Length LT	3.75		4.38		5.00		5.62		6.25		6.88		7.50	
Body Diameter D	min.	max.	min.	max.	min.	max.	min.	max.	min.	max.	min.	max.	min.	max.
	1.4818	1.5000	1.7295	1.7500	1.9780	2.0000	2.2280	2.2500	2.4762	2.5000	2.7262	2.7500	2.9762	3.000
Head Dia. A	min.	max.	min.	max.	min.	max.	min.	max.	min.	max.	min.	max.	min.	max.
	2.224	2.250	2.597	2.625	2.970	3.000	3.344	3.375	3.717	3.750	4.090	4.125	4.464	4.500
Head Height H	min.	max.	min.	max.	min.	max.	min.	max.	min.	max.	min.	max.	min.	max.
	1.485	1.500	1.734	1.750	1.983	2.000	2.232	2.250	2.481	2.500	2.730	2.750	2.979	3.000
Key Size nominal J	1 (1.000)		1 1/4 (1.250)		1 1/2 (1.500)		1 3/4 (1.750)		1 3/4 (1.750)		2 (2.000)		2 1/4 (2.250)	
Key Engagement T	min.		min.		min.		min.		min.		min.		min.	
	0.745		0.870		0.995		1.120		1.245		1.370		1.495	

FOR MORE DETAILED INFORMATION, PLEASE REFER TO COMPLETE ASME STANDARD, WHICH IS THE GOVERNING STANDARD

ASME B18.3 (R2008) LFG 10/01/2016

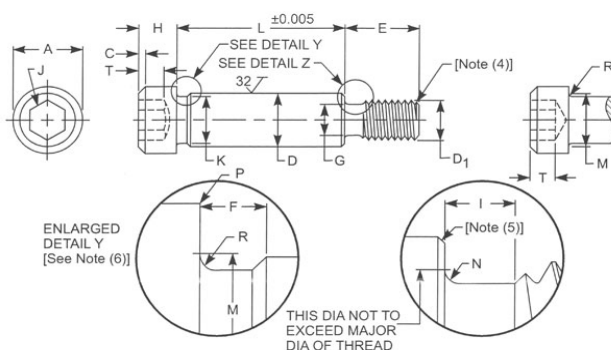

Shoulder Size	1/4		5/16		3/8		1/2		5/8	
Shoulder Diameter D	min.	max.	min.	max.	min.	max.	min.	max.	min.	max.
	0.2460	0.2480	0.3085	0.3105	0.3710	0.3730	0.4960	0.4980	0.6210	0.6230
Nominal Thread Size	Diameter	TPI	Diameter	TPI	Diameter	TPI	Diameter	TPI	Diameter	TPI
	10	24	1/4	20	5/16	18	3/8	16	1/2	13
Head Dia. A	min.	max.	min.	max.	min.	max.	min.	max.	min.	max.
	0.357	0.375	0.419	0.438	0.543	0.562	0.729	0.750	0.853	0.875
Head Height H	min.	max.	min.	max.	min.	max.	min.	max.	min.	max.
	0.177	0.188	0.209	0.219	0.240	0.250	0.302	0.312	0.365	0.375
Hexagon Socket Size J	1/8 (0.125)		5/32 (0.156)		3/16 (0.188)		1/4 (0.250)		5/16 (0.312)	
Key Engagement T	min.		min.		min.		min.		min.	
	0.094		0.117		0.141		0.188		0.234	
Shoulder Neck Dia. K	min.		min.		min.		min.		min.	
	0.227		0.289		0.352		0.477		0.602	
Shoulder Neck Width F	max.		max.		max.		max.		max.	
	0.093		0.093		0.093		0.093		0.093	
Thread Neck Dia. G	min.	max.	min.	max.	min.	max.	min.	max.	min.	max.
	0.133	0.142	0.182	0.193	0.237	0.249	0.291	0.304	0.397	0.414
Thread Length	basic.		basic.		basic.		basic.		basic.	
	0.375		0.438		0.500		0.625		0.750	

Shoulder Size	3/4		1		1-1/4		1-1/2		1-3/4	
Shoulder Diameter D	min.	max.	min.	max.	min.	max.	min.	max.	min.	max.
	0.7460	0.7480	0.9960	0.9980	1.2460	1.2480	1.4960	1.4980	1.7460	1.7480
Nominal Thread Size	Diameter	TPI	Diameter	TPI	Diameter	TPI	Diameter	TPI	Diameter	TPI
	5/8	11	3/4	10	7/8	9	1 1/8	7	1 1/4	7
Head Dia. A	min.	max.	min.	max.	min.	max.	min.	max.	min.	max.
	0.977	1.000	1.287	1.312	1.723	1.750	2.095	2.125	2.345	2.375
Head Height H	min.	max.	min.	max.	min.	max.	min.	max.	min.	max.
	0.490	0.500	0.610	0.625	0.735	0.750	0.980	1.000	1.105	1.125
Hexagon Socket Size J	3/8 (0.375)		1/2 (0.500)		5/8 (0.625)		7/8 (0.875)		1 (1.000)	
Key Engagement T	min.		min.		min.		min.		min.	
	0.281		0.375		0.469		0.656		0.750	
Shoulder Neck Dia. K	min.		min.		min.		min.		min.	
	0.727		0.977		1.227		1.478		1.728	
Shoulder Neck Width F	max.		max.		max.		max.		max.	
	0.093		0.125		0.125		0.125		0.125	
Thread Neck Dia. G	min.	max.	min.	max.	min.	max.	min.	max.	min.	max.
	0.502	0.521	0.616	0.638	0.726	0.750	0.934	0.964	1.059	1.089
Thread Length	basic.		basic.		basic.		basic.		basic.	
	0.875		1.000		1.125		1.500		1.750	

FOR MORE DETAILED INFORMATION, PLEASE REFER TO COMPLETE ASME STANDARD, WHICH IS THE GOVERNING STANDARD

ASME B18.3 (R2008) LFG 10/01/2016

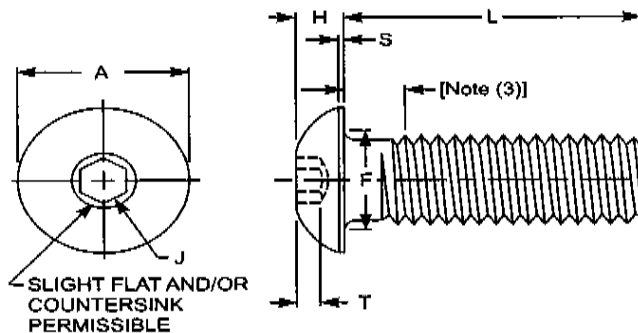

Thread Size	# 0		# 1		# 2		# 3		# 4	
Head Dia. A	min.	max.	min.	max.	min.	max.	min.	max.	min.	max.
	0.104	0.114	0.129	0.139	0.154	0.164	0.176	0.188	0.201	0.213
Head Height H	min.	max.	min.	max.	min.	max.	min.	max.	min.	max.
	0.026	0.032	0.033	0.039	0.038	0.046	0.044	0.052	0.051	0.059
Head Side Height S	ref.		ref.		ref.		ref.		ref.	
	0.010		0.010		0.010		0.010		0.015	
Hexagon Socket Size J	Nominal		Nominal		Nominal		Nominal		Nominal	
	0.035		0.050		0.050		1/16 (0.062)		1/16 (0.062)	
Key Engagement T	min.		min.		min.		min.		min.	
	0.020		0.028		0.028		0.035		0.035	

Thread Size	#5		#6		# 8		# 10		1/4	
Head Dia. A	min.	max.	min.	max.	min.	max.	min.	max.	min.	max.
	0.226	0.238	0.250	0.262	0.298	0.312	0.347	0.361	0.419	0.437
Head Height H	min.	max.	min.	max.	min.	max.	min.	max.	min.	max.
	0.058	0.066	0.063	0.073	0.077	0.087	0.091	0.101	0.122	0.132
Head Side Height S	ref.		ref.		ref.		ref.		ref.	
	0.015		0.015		0.015		0.020		0.031	
Hexagon Socket Size J	Nominal		Nominal		Nominal		Nominal		Nominal	
	5/64 (0.078)		5/64 (0.078)		3/32 (0.094)		1/8 (0.125)		5/32 (0.156)	
Key Engagement T	min.		min.		min.		min.		min.	
	0.044		0.044		0.052		0.070		0.087	

Thread Size d1	5/16		3/8		1/2		5/8	
Head Dia. A	min.	max.	min.	max.	min.	max.	min.	max.
	0.527	0.547	0.636	0.656	0.851	0.875	0.970	1.000
Head Height H	min.	max.	min.	max.	min.	max.	min.	max.
	0.152	0.166	0.185	0.199	0.245	0.265	0.311	0.331
Head Side Height S	ref.		ref.		ref.		ref.	
	0.031		0.031		0.046		0.062	
Hexagon Socket Size J	Nominal		Nominal		Nominal		Nominal	
	3/16 (0.188)		7/32 (0.219)		5/16 (0.312)		3/8 (0.375)	
Key Engagement T	min.		min.		min.		min.	
	0.105		0.122		0.175		0.210	

FOR MORE DETAILED INFORMATION, PLEASE REFER TO COMPLETE ASME STANDARD, WHICH IS THE GOVERNING STANDARD

ASME B18.3 (R2008) LFG 10/01/2016

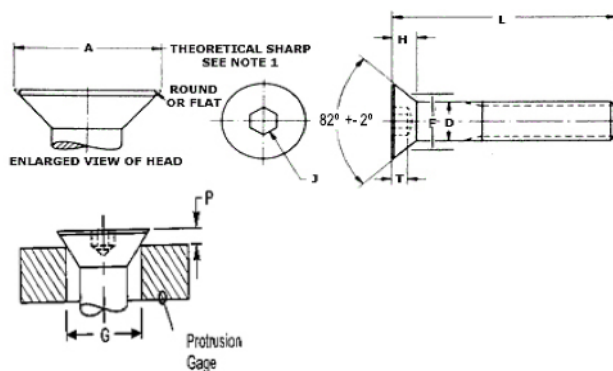

Thread Size	# 0		# 1		# 2		# 3		# 4		# 5	
Body Diameter D	min.	max.	min.	max.	min.	max.	min.	max.	min.	max.	min.	max.
	0.0568	0.0600	0.0695	0.0730	0.0822	0.0860	0.0949	0.0990	0.1075	0.1120	0.1202	0.1250
Head Dia. A	min.	max.	min.	max.	min.	max.	min.	max.	min.	max.	min.	max.
	0.117	0.138	0.143	0.168	0.168	0.197	0.193	0.226	0.218	0.255	0.240	0.281
Head Height H	ref.		ref.		ref.		ref.		ref.		ref.	
	0.044		0.054		0.064		0.073		0.083		0.090	
Hexagon Socket Size J	(0.035)		(0.050)		(0.050)		1/16 (0.062)		1/16 (0.062)		5/64 (0.078)	
Key Engagement T	min.		min.		min.		min.		min.		min.	
	0.025		0.031		0.038		0.044		0.055		0.061	

Thread Size	# 6		# 8		# 10		1/4		5/16		3/8	
Body Diameter D	min.	max.	min.	max.	min.	max.	min.	max.	min.	max.	min.	max.
	0.1329	0.1380	0.1585	0.1640	0.1840	0.1900	0.2435	0.2500	0.3053	0.3125	0.3678	0.3750
Head Dia. A	min.	max.	min.	max.	min.	max.	min.	max.	min.	max.	min.	max.
	0.263	0.307	0.311	0.359	0.359	0.411	0.480	0.531	0.600	0.656	0.720	0.781
Head Height H	ref.		ref.		ref.		ref.		ref.		ref.	
	0.097		0.112		0.127		0.161		0.198		0.234	
Hexagon Socket Size J	5/64 (0.078)		3/32 (0.094)		1/8 (0.125)		5/32 (0.156)		3/16 (0.188)		7/32 (0.219)	
Key Engagement T	min.		min.		min.		min.		min.		min.	
	0.066		0.076		0.087		0.111		0.135		0.159	

Thread Size d1	7/16		1/2		5/8		3/4		7/8		1	
Body Diameter D	min.	max.	min.	max.	min.	max.	min.	max.	min.	max.	min.	max.
	0.4294	0.4375	0.4919	0.5000	0.6163	0.6250	0.7406	0.7500	0.8647	0.8750	0.9886	1.0000
Head Dia. A	min.	max.	min.	max.	min.	max.	min.	max.	min.	max.	min.	max.
	0.781	0.844	0.872	0.938	1.112	1.188	1.355	1.438	1.604	1.688	1.841	1.938
Head Height H	ref.		ref.		ref.		ref.		ref.		ref.	
	0.234		0.251		0.324		0.396		0.468		0.540	
Hexagon Socket Size J	1/4 (0.250)		5/16 (0.312)		3/8 (0.375)		1/2 (0.500)		9/16 (0.562)		5/8 (0.625)	
Key Engagement T	min.		min.		min.		min.		min.		min.	
	0.159		0.172		0.220		0.220		0.248		0.297	

Thread Size d1	1-1/8		1-1/4		1-3/8		1-1/2	
Body Diameter D	min.	max.	min.	max.	min.	max.	min.	max.
	1.1086	1.1250	1.2336	1.2500	1.3568	1.3750	1.4818	1.5000
Head Dia. A	min.	max.	min.	max.	min.	max.	min.	max.
	2.079	2.188	2.316	2.438	2.553	2.688	2.791	2.938
Head Height H	ref.		ref.		ref.		ref.	
	0.611		0.683		0.755		0.827	
Hexagon Socket Size J	3/4 (0.750)		7/8 (0.875)		7/8 (0.875)		1 (1.000)	
Key Engagement T	min.		min.		min.		min.	
	0.325		0.358		0.402		0.435	

FOR MORE DETAILED INFORMATION, PLEASE REFER TO COMPLETE ASME STANDARD, WHICH IS THE GOVERNING STANDARD

ASME B18.3 (R2008) LFG 10/01/2016

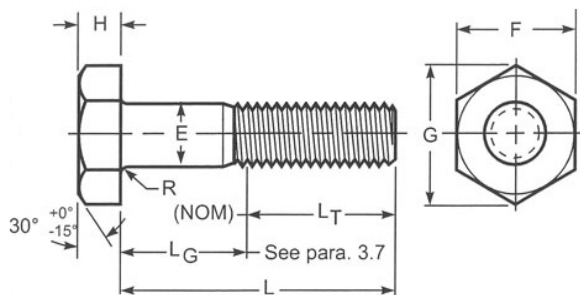

For Screws Not Fully Threaded, The Thread Length Shown Is Minimum

Thread Size	1/4		5/16		3/8		7/16		1/2		9/16		5/8	
Thread Length LT	6 inch and under	Over 6 inches	6 inch and under	Over 6 inches	6 inch and under	Over 6 inches	6 inch and under	Over 6 inches	6 inch and under	Over 6 inches	6 inch and under	Over 6 inches	6 inch and under	Over 6 inches
	0.750	1.000	0.875	1.125	1.000	1.250	1.125	1.375	1.250	1.500	1.375	1.625	1.500	1.750
Body Diameter E	min.	max.	min.	max.	min.	max.	min.	max.	min.	max.	min.	max.	min.	max.
	0.2450	0.2500	0.3065	0.3125	0.3690	0.3750	0.4305	0.4375	0.4930	0.5000	0.5545	0.5625	0.6170	0.6250
Width Across Flats F	min.	max.	min.	max.	min.	max.	min.	max.	min.	max.	min.	max.	min.	max.
	0.428	0.438	0.489	0.500	0.551	0.562	0.612	0.625	0.736	0.750	0.798	0.812	0.922	0.938
Head Height H	min.	max.	min.	max.	min.	max.	min.	max.	min.	max.	min.	max.	min.	max.
	0.150	0.163	0.195	0.211	0.226	0.243	0.272	0.291	0.302	0.323	0.348	0.371	0.378	0.403
Wrenching Height J	min.		min.		min.		min.		min.		min.		min.	
	0.106		0.140		0.160		0.195		0.215		0.250		0.269	

Thread Size	3/4		7/8		1		1-1/8		1-1/4		1-3/8		1-1/2	
Thread Length LT	6 inch and under	Over 6 inches	6 inch and under	Over 6 inches	6 inch and under	Over 6 inches	6 inch and under	Over 6 inches	6 inch and under	Over 6 inches	6 inch and under	Over 6 inches	6 inch and under	Over 6 inches
	1.750	2.000	2.000	2.250	2.250	2.500	2.500	2.750	2.750	3.000	3.000	3.250	3.250	3.500
Body Diameter E	min.	max.	min.	max.	min.	max.	min.	max.	min.	max.	min.	max.	min.	max.
	0.7410	0.7500	0.8660	0.8750	0.9900	1.0000	1.1140	1.1250	1.2390	1.2500	1.3630	1.3750	1.4880	1.5000
Width Across Flats F	min.	max.	min.	max.	min.	max.	min.	max.	min.	max.	min.	max.	min.	max.
	1.100	1.125	1.285	1.312	1.469	1.500	1.631	1.688	1.812	1.875	1.994	2.062	2.175	2.250
Head Height H	min.	max.	min.	max.	min.	max.	min.	max.	min.	max.	min.	max.	min.	max.
	0.455	0.483	0.531	0.563	0.591	0.627	0.658	0.718	0.749	0.813	0.810	0.878	0.902	0.974
Wrenching Height J	min.		min.		min.		min.		min.		min.		min.	
	0.324		0.378		0.416		0.461		0.530		0.569		0.640	

Thread Size	1-3/4		2		2-1/4		2-1/2		2-3/4		3	
Thread Length LT	6 inch and under	Over 6 inches	6 inch and under	Over 6 inches	6 inch and under	Over 6 inches	6 inch and under	Over 6 inches	6 inch and under	Over 6 inches	6 inch and under	Over 6 inches
	3.750	4.000	4.250	4.500		5.000		5.500		6.000		6.500
Body Diameter E	min.	max.	min.	max.	min.	max.	min.	max.	min.	max.	min.	max.
	1.7380	1.7500	1.9880	2.0000	2.2380	2.2500	2.4880	2.5000	2.7380	2.7500	2.9880	3.0000
Width Across Flats F	min.	max.	min.	max.	min.	max.	min.	max.	min.	max.	min.	max.
	2.538	2.625	2.900	3.000	3.262	3.375	3.625	3.750	3.988	4.125	4.350	4.500
Head Height H	min.	max.	min.	max.	min.	max.	min.	max.	min.	max.	min.	max.
	1.054	1.134	1.175	1.263	1.327	1.423	1.479	1.583	1.632	1.744	1.815	1.935
Wrenching Height J	min.		min.		min.		min.		min.		min.	
	0.748		0.825		0.933		1.042		1.151		1.290	

FOR MORE DETAILED INFORMATION, PLEASE REFER TO COMPLETE ASME STANDARD, WHICH IS THE GOVERNING STANDARD

ASME B 18.2.1 (2010) LFG 10/01/2016

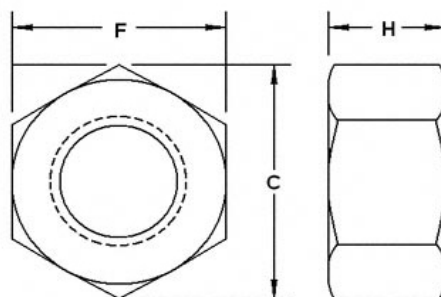

14.1 - INCH FULL HEX NUTS

Thread Size	1/4		5/16		3/8		7/16		1/2	
Width Across Flats F	min.	max.	min.	max.	min.	max.	min.	max.	min.	max.
	0.428	0.438	0.489	0.500	0.551	0.563	0.675	0.688	0.736	0.750
Width Across Corners G	min.	max.	min.	max.	min.	max.	min.	max.	min.	max.
	0.488	0.505	0.557	0.577	0.628	0.650	0.768	0.794	0.840	0.866
Thickness H	min.	max.	min.	max.	min.	max.	min.	max.	min.	max.
	0.212	0.226	0.258	0.273	0.320	0.337	0.365	0.385	0.427	0.448
Specified Proof Load	up to 150,000 psi	150,000 psi and greater	up to 150,000 psi	150,000 psi and greater	up to 150,000 psi	150,000 psi and greater	up to 150,000 psi	150,000 psi and greater	up to 150,000 psi	150,000 psi and greater
	0.015	0.010	0.016	0.011	0.017	0.012	0.018	0.013	0.019	0.014

Thread Size	9/16		5/8		3/4		7/8		1	
Width Across Flats F	min.	max.	min.	max.	min.	max.	min.	max.	min.	max.
	0.861	0.875	0.922	0.938	1.088	1.125	1.269	1.312	1.450	1.500
Width Across Corners G	min.	max.	min.	max.	min.	max.	min.	max.	min.	max.
	0.982	1.010	1.051	1.083	1.240	1.299	1.447	1.516	1.653	1.732
Thickness H	min.	max.	min.	max.	min.	max.	min.	max.	min.	max.
	0.473	0.496	0.535	0.559	0.617	0.665	0.724	0.776	0.831	0.887
Specified Proof Load	up to 150,000 psi	150,000 psi and greater	up to 150,000 psi	150,000 psi and greater	up to 150,000 psi	150,000 psi and greater	up to 150,000 psi	150,000 psi and greater	up to 150,000 psi	150,000 psi and greater
	0.020	0.015	0.021	0.016	0.023	0.018	0.025	0.020	0.027	0.022

Thread Size	1-1/8		1-1/4		1-3/8		1-1/2		1-3/4	
Width Across Flats F	min.	max.	min.	max.	min.	max.	min.	max.	min.	max.
	1.631	1.688	1.812	1.875	1.994	2.062	2.175	2.250	2.538	2.625
Width Across Corners G	min.	max.	min.	max.	min.	max.	min.	max.	min.	max.
	1.859	1.949	2.066	2.165	2.273	2.382	2.480	2.598	2.893	3.031
Thickness H	min.	max.	min.	max.	min.	max.	min.	max.	min.	max.
	0.939	0.999	1.030	1.094	1.138	1.206	1.245	1.317	1.460	1.540
Specified Proof Load	up to 150,000 psi	150,000 psi and greater	up to 150,000 psi	150,000 psi and greater	up to 150,000 psi	150,000 psi and greater	up to 150,000 psi	150,000 psi and greater	up to 150,000 psi	150,000 psi and greater
	0.030	0.025	0.033	0.028	0.036	0.031	0.039	0.034	0.048	0.041

Thread Size	2		2-1/4		2-1/2		2-3/4		3-1/2	
Width Across Flats F	min.	max.	min.	max.	min.	max.	min.	max.	min.	max.
	2.900	3.000	3.263	3.375	3.625	3.750	4.350	4.500	5.075	5.250
Width Across Corners G	min.	max.	min.	max.	min.	max.	min.	max.	min.	max.
	3.306	3.464	3.719	3.897	4.133	4.330	4.959	5.196	5.786	6.062
Thickness H	min.	max.	min.	max.	min.	max.	min.	max.	min.	max.
	1.675	1.763	1.890	1.986	2.105	2.209	2.534	2.654	2.964	3.100
Specified Proof Load	up to 150,000 psi	150,000 psi and greater	up to 150,000 psi	150,000 psi and greater	up to 150,000 psi	150,000 psi and greater	up to 150,000 psi	150,000 psi and greater	up to 150,000 psi	150,000 psi and greater
	0.055	0.047	0.061	0.052	0.068	0.058	0.081	0.070	0.094	0.081

FOR MORE DETAILED INFORMATION, PLEASE REFER TO COMPLETE ASME STANDARD, WHICH IS THE GOVERNING STANDARD

ASME B18.2.2 (2010) LFG 10/01/2016



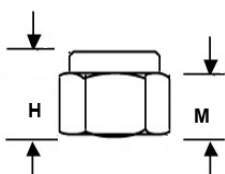
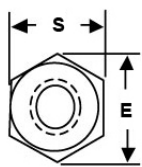

Nylon Temperature Range
- 58° to + 250° F

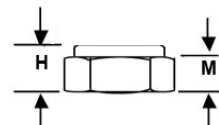
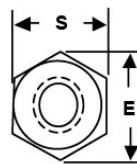

Machine Screw Pattern	NM Series					
Thread Size	#2		#5**		#6	
Width Across Flats S	min.	max.	min.	max.	min.	max.
	0.243	0.251	0.243	0.251	0.305	0.313
Width Across Corners E	ref.		ref.		ref.	
	0.268		0.268		0.339	
Thickness H	min.	max.	min.	max.	min.	max.
	0.133	0.153	0.133	0.153	0.168	0.188
Wrenching height M	ref.		ref.		ref.	
	0.081		0.081		0.103	

Thread Size	#8		#10		#12	
Width Across Flats S	min.	max.	min.	max.	min.	max.
	0.336	0.345	0.367	0.376	0.430	0.439
Width Across Corners E	ref.		ref.		ref.	
	0.374		0.410		0.482	
Thickness H	min.	max.	min.	max.	min.	max.
	0.219	0.239	0.229	0.249	0.298	0.328
Wrenching height M	ref.		ref.		ref.	
	0.140		0.140		0.225	

#5** Diameter Not According To ASME B18.16.6, But To Dimensions Above

NTM Series							
#2		#3		#4		#5	
min.	max.	min.	max.	min.	max.	min.	max.
0.243	0.251	0.243	0.251	0.243	0.251	0.243	0.251
ref.		ref.		ref.		ref.	
0.268		0.268		0.268		0.268	
min.	max.	min.	max.	min.	max.	min.	max.
0.094	0.124	0.094	0.124	0.094	0.124	0.094	0.124
ref.		ref.		ref.		ref.	
0.075**		0.075**		0.075**		0.075**	

#6		#8		#10		#12	
min.	max.	min.	max.	min.	max.	min.	max.
0.305	0.313	0.336	0.345	0.367	0.376	0.430	0.439
ref.		ref.		ref.		ref.	
0.339		0.374		0.410		0.482	
min.	max.	min.	max.	min.	max.	min.	max.
0.110	0.140	0.157	0.187	0.157	0.187	0.188	0.218
ref.		ref.		ref.		ref.	
0.090**		0.110**		0.110**		0.125**	

D Dimension Reference** ASME Only

FOR MORE DETAILED INFORMATION, PLEASE REFER TO COMPLETE STANDARD WHICH IS THE GOVERNING STANDARD

ASME B18.16.6 (2014) LFG 10/01/2016

INCH NYLON INSERT LOCK NUTS - LIGHT PATTERN, FULL HEIGHT (NE SERIES) - ASME B 18.16.6

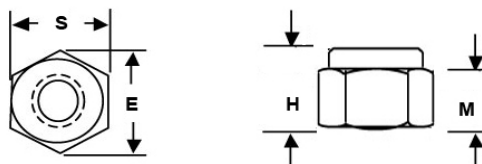

Nylon Temperature Range
- 58° to + 250° F

Light Pattern	NE Series													
Thread Size	1/4		5/16		3/8		7/16		1/2		9/16		5/8	
Width Across Flats S	min.	max.	min.	max.	min.	max.	min.	max.	min.	max.	min.	max.	min.	max.
	0.430	0.439	0.489	0.502	0.551	0.564	0.616	0.627	0.736	0.752	0.861	0.877	0.922	0.940
Width Across Corners E	ref.		ref.		ref.		ref.		ref.		ref.		ref.	
	0.482		0.552		0.622		0.698		0.837		0.978		1.051	
Thickness H	min.	max.	min.	max.	min.	max.	min.	max.	min.	max.	min.	max.	min.	max.
	0.298	0.328	0.329	0.359	0.438	0.468	0.438	0.468	0.579	0.609	0.626	0.656	0.735	0.765
Wrenching height M	ref.		ref.		ref.		ref.		ref.		ref.		ref.	
	0.225		0.250		0.335		0.324		0.464		0.469		0.593	

Thread Size	3/4		7/8		1		1-1/8		1-1/4		1-3/8		1-1/2	
Width Across Flats S	min.	max.	min.	max.	min.	max.	min.	max.	min.	max.	min.	max.	min.	max.
	1.052	1.064	1.239	1.252	1.427	1.440	1.614	1.627	1.801	1.815	1.973	2.008	2.159	2.197
Width Across Corners E	ref.		ref.		ref.		ref.		ref.		ref.		ref.	
	1.191		1.403		1.615		1.826		2.038		2.232		2.444	
Thickness H	min.	max.	min.	max.	min.	max.	min.	max.	min.	max.	min.	max.	min.	max.
	0.860	0.890	0.969	0.999	1.016	1.078	1.141	1.203	1.360	1.422	1.547	1.609	1.578	1.640
Wrenching height M	ref.		ref.		ref.		ref.		ref.		ref.		ref.	
	0.742		0.790		0.825		0.930		1.125		1.282		1.313	

INCH NYLON INSERT LOCK NUTS - LIGHT PATTERN, THIN HEIGHT (NTE SERIES) - ASME B 18.16.6

Nylon Temperature Range - 58° to + 250° F

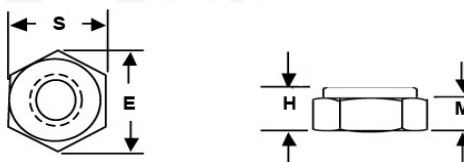

Thread Size	1/4		5/16		3/8		7/16		1/2		9/16		5/8	
Width Across Flats S	min.	max.	min.	max.	min.	max.	min.	max.	min.	max.	min.	max.	min.	max.
	0.430	0.439	0.492	0.502	0.553	0.564	0.616	0.627	0.741	0.752	0.865	0.877	0.928	0.940
Width Across Corners E	ref.		ref.		ref.		ref.		ref.		ref.		ref.	
	0.482		0.552		0.622		0.694		0.837		0.978		1.051	
Thickness H	min.	max.	min.	max.	min.	max.	min.	max.	min.	max.	min.	max.	min.	max.
	0.188	0.218	0.235	0.265	0.251	0.281	0.298	0.327	0.298	0.327	0.344	0.374	0.376	0.386
Wrenching height M	ref.		ref.		ref.		ref.		ref.		ref.		ref.	
	0.125		0.158		0.150		0.225		0.190		0.225		0.265	

Thread Size	3/4		7/8		1		1-1/8		1-1/4		1-3/8		1-1/2	
Width Across Flats S	min.	max.	min.	max.	min.	max.	min.	max.	min.	max.	min.	max.	min.	max.
	1.052	1.064	1.239	1.252	1.427	1.440	1.614	1.627	1.801	1.815	1.973	2.008	2.159	2.197
Width Across Corners E	ref.		ref.		ref.		ref.		ref.		ref.		ref.	
	1.191		1.403		1.615		1.826		2.038		2.232		2.416	
Thickness H	min.	max.	min.	max.	min.	max.	min.	max.	min.	max.	min.	max.	min.	max.
	0.391	0.421	0.454	0.484	0.516	0.578	0.703	0.765	0.703	0.765	0.759	0.821	0.766	0.828
Wrenching height M	ref.		ref.		ref.		ref.		ref.		ref.		ref.	
	0.288		0.340		0.405		0.500		0.523		0.493		0.565	

FOR MORE DETAILED INFORMATION, PLEASE REFER TO COMPLETE STANDARD WHICH IS THE GOVERNING STANDARD

ASME B18.16.6 (2014) LFG 10/01/2016

1/4 - INCH HEAVY NYLON INSERT LOCK NUTS - HEAVY PATTERN, FULL HEIGHT (NU SERIES) ▪ ASME B 18.16.6

Nylon Temperature Range - 58°
to + 250° F

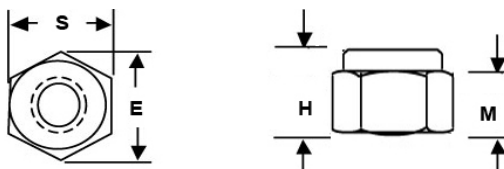

Thread Size	1/4		5/16		3/8		7/16		1/2		5/8		3/4	
Width Across Flats S	min.	max.	min.	max.	min.	max.	min.	max.	min.	max.	min.	max.	min.	max.
	0.489	0.503	0.551	0.566	0.675	0.691	0.736	0.754	0.861	0.879	1.045	1.067	1.231	1.255
Width Across Corners E	ref.		ref.		ref.		ref.		ref.		ref.		ref.	
	0.556		0.624		0.763		0.829		0.969		1.175		1.382	
Thickness H	min.	max.	min.	max.	min.	max.	min.	max.	min.	max.	min.	max.	min.	max.
	0.360	0.390	0.423	0.453	0.532	0.562	0.579	0.609	0.688	0.718	0.844	0.874	0.985	1.015
Wrenching height M	ref.		ref.		ref.		ref.		ref.		ref.		ref.	
	0.290		0.335		0.392		0.464		0.544		0.677		0.790	

Thread Size	7/8		1		1-1/8		1-1/4		1-1/2		1-3/4		2	
Width Across Flats S	min.	max.	min.	max.	min.	max.	min.	max.	min.	max.	min.	max.	min.	max.
	1.417	1.444	1.602	1.632	1.788	2.002	1.973	2.008	2.344	2.384	2.715	2.762	3.086	3.137
Width Across Corners E	ref.		ref.		ref.		ref.		ref.		ref.		ref.	
	1.589		1.796		2.002		2.209		2.622		3.035		3.449	
Thickness H	min.	max.	min.	max.	min.	max.	min.	max.	min.	max.	min.	max.	min.	max.
	1.110	1.140	1.250	1.312	1.407	1.469	1.611	1.672	1.891	1.953	2.250	2.376	2.343	2.469
Wrenching height M	ref.		ref.		ref.		ref.		ref.		ref.		ref.	
	0.883		1.000		1.096		1.250		1.413		1.830		1.750	

1/4 - INCH HEAVY NYLON INSERT LOCK NUTS - HEAVY PATTERN, THIN HEIGHT (NTU SERIES) ▪ ASME B 18.16.6

Nylon Temperature Range - 58°
to + 250° F

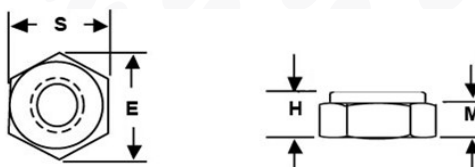

Thread Size	1/4		5/16		3/8		7/16		1/2		5/8		3/4	
Width Across Flats S	min.	max.	min.	max.	min.	max.	min.	max.	min.	max.	min.	max.	min.	max.
	0.492	0.502	0.553	0.564	0.679	0.690	0.741	0.752	0.865	0.877	1.052	1.064	1.239	1.252
Width Across Corners E	ref.		ref.		ref.		ref.		ref.		ref.		ref.	
	0.552		0.622		0.766		0.837		0.978		1.191		1.403	
Thickness H	min.	max.	min.	max.	min.	max.	min.	max.	min.	max.	min.	max.	min.	max.
	0.266	0.296	0.298	0.328	0.391	0.421	0.423	0.453	0.516	0.546	0.594	0.624	0.688	0.718
Wrenching height M	ref.		ref.		ref.		ref.		ref.		ref.		ref.	
	0.194		0.212		0.251		0.316		0.360		0.428		0.488	

Thread Size	7/8		1		1 1/8		1 1/4		1 1/2		1 3/4		2	
Width Across Flats S	min.	max.	min.	max.	min.	max.	min.	max.	min.	max.	min.	max.	min.	max.
	1.427	1.440	1.614	1.627	1.801	1.814	1.973	2.008	2.344	2.384	2.715	2.762	3.086	3.137
Width Across Corners E	ref.		ref.		ref.		ref.		ref.		ref.		ref.	
	1.615		1.826		2.038		2.232		2.622		3.075		3.497	
Thickness H	min.	max.	min.	max.	min.	max.	min.	max.	min.	max.	min.	max.	min.	max.
	0.766	0.796	0.860	0.922	0.938	1.000	1.078	1.140	1.282	1.344	1.406	1.532	1.609	1.735
Wrenching height M	ref.		ref.		ref.		ref.		ref.		ref.		ref.	
	0.535		0.600		0.627		0.720		0.810		0.986		1.016	

FOR MORE DETAILED INFORMATION, PLEASE REFER TO COMPLETE STANDARD, WHICH IS THE GOVERNING STANDARD

ASME B 18.16.6 (2014) LFG 10/01/2016

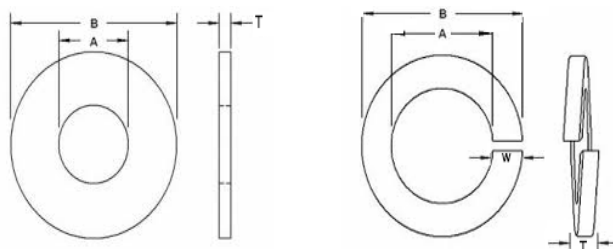

Size	USS FLAT WASHERS ASME B18.21.1						SAE FLAT WASHERS ASME B18.21.1						LOCK WASHERS ASME B18.21.1				
	A Inside		B Outside		T Thickness		A Inside		B Outside		T Thickness		A Inside		B Outside	T Thickness	W Width
	Min	Max	Min	Max	Min	Max	Min	Max	Min	Max	Min	Max	Min	Max	Max	Min	Min
#2							0.089	0.094	0.245	0.250	0.016	0.025	0.088	0.094	0.172	0.020	0.035
#3													0.101	0.107	0.195	0.025	0.040
#4							0.120	0.133	0.307	0.320	0.025	0.040	0.114	0.120	0.209	0.025	0.040
#5													0.127	0.133	0.236	0.031	0.047
#6							0.151	0.164	0.370	0.390	0.036	0.065	0.141	0.148	0.250	0.031	0.047
#8							0.183	0.196	0.433	0.453	0.036	0.065	0.167	0.174	0.293	0.040	0.055
#10							0.214	0.227	0.495	0.515	0.036	0.065	0.193	0.200	0.334	0.047	0.062
3/16							0.245	0.265	0.557	0.577	0.036	0.065					
#12							0.245	0.265	0.557	0.577	0.051	0.080	0.220	0.227	0.377	0.056	0.070
1/4	0.307	0.327	0.727	0.749	0.051	0.080	0.276	0.296	0.620	0.640	0.051	0.080	0.252	0.260	0.487	0.062	0.109
5/16	0.370	0.390	0.882	0.905	0.064	0.104	0.339	0.359	0.681	0.703	0.051	0.080	0.314	0.322	0.583	0.078	0.125
3/8	0.433	0.453	1.007	1.030	0.064	0.404	0.401	0.421	0.805	0.827	0.051	0.080	0.377	0.385	0.680	0.094	0.141
7/16	0.495	0.515	1.257	1.280	0.064	0.404	0.464	0.484	0.915	0.937	0.051	0.080	0.440	0.450	0.776	0.109	0.156
1/2	0.557	0.577	1.382	1.405	0.086	0.132	0.526	0.546	1.055	1.092	0.074	0.121	0.502	0.512	0.869	0.125	0.171
9/16	0.620	0.640	1.476	1.499	0.086	0.132	0.589	0.609	1.149	1.186	0.074	0.121	0.564	0.574	0.965	0.141	0.188
5/8	0.681	0.718	1.757	1.780	0.108	0.160	0.649	0.686	1.305	1.342	0.074	0.121	0.628	0.641	1.073	0.156	0.203
3/4	0.805	0.842	2.007	2.030	0.122	0.177	0.805	0.842	1.462	1.499	0.108	0.160	0.753	0.766	1.265	0.188	0.234
7/8	0.931	0.968	2.257	2.280	0.136	0.192	0.931	0.968	1.743	1.780	0.108	0.160	0.878	0.894	1.459	0.219	0.266
1	1.055	1.092	2.507	2.530	0.136	0.192	1.055	1.092	1.993	2.030	0.108	0.160	1.003	1.024	1.656	0.250	0.297
1-1/8	1.243	1.280	2.757	2.780	0.136	0.192	1.243	1.280	2.243	2.280	0.108	0.160	1.129	1.153	1.847	0.281	0.328
1-1/4	1.368	1.405	3.007	3.030	0.136	0.192	1.368	1.405	2.493	2.530	0.136	0.192	1.254	1.280	2.036	0.312	0.359
1-3/8	1.490	1.545	3.260	3.295	0.153	0.213	1.493	1.530	2.743	2.780	0.136	0.192	1.379	1.408	2.219	0.344	0.391
1-1/2	1.615	1.670	3.510	3.545	0.153	0.213	1.618	1.655	2.993	3.030	0.136	0.192	1.504	1.534	2.419	0.375	0.422
1-3/4	1.865	1.920	4.010	4.045	0.153	0.213							1.758	1.789	2.679	0.389	0.424
2	2.115	2.170	4.510	4.545	0.153	0.213							2.008	2.039	2.936	0.422	0.427
2-1/4	2.365	2.420	4.760	4.795	0.193	0.248							2.262	2.293	3.221	0.440	0.442
2-1/2	2.615	2.670	5.010	5.045	0.210	0.280							2.512	2.543	3.471	0.440	0.442
2-3/4	2.865	2.940	5.260	5.315	0.228	0.310							2.762	2.793	3.824	0.458	0.491
3	3.115	3.190	5.510	5.565	0.249	0.327							3.012	3.043	4.074	0.458	0.491

15.1 - INCH FLAT AND LOCK WASHERS

FOR MORE DETAILED INFORMATION, PLEASE REFER TO COMPLETE STANDARD WHICH IS THE GOVERNING STANDARD

ASME B18.21.1 (2009) LFG 10/01/2016



Get quote »

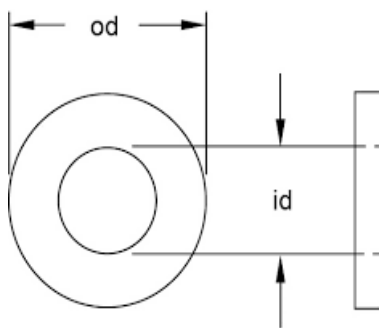

Machine bushings ASTM F844								
8 GA. .042-.054	ID	OD	14 GA. .068-.082	ID	OD	10 GA. .126-.142	ID	OD
18 x 1/2 x 7/8	1/2"	7/8"	14 x 1/2 x 7/8	1/2"	7/8"	10 x 1/2 x 7/8	1/2"	7/8"
18 x 9/16 x 15/16	9/16"	15/16"	14 x 9/16 x 15/16	9/16"	15/16"	10 x 9/16 x 15/16	9/16"	15/16"
18 x 5/8 x 1	5/8"	1"	14 x 5/8 x 1	5/8"	1"	10 x 5/8 x 1	5/8"	1"
18 x 3/4 x 1-1/4	3/4"	1-1/4"	14 x 3/4 x 1-1/4	3/4"	1-1/4"	10 x 3/4 x 1-1/4	3/4"	1-1/4"
18 x 7/8 x 1-3/8	7/8"	1-3/8"	14 x 7/8 x 1-3/8	7/8"	1-3/8"	10 x 7/8 x 1-3/8	7/8"	1-3/8"
18 x 1 x 1-1/2	1"	1-1/2"	14 x 1 x 1-1/2	1"	1-1/2"	10 x 1 x 1-1/2	1"	1-1/2"
18 x 1-1/8 x 1-3/4	1-1/8"	1-3/4"	14 x 1-1/8 x 1-3/4	1-1/8"	1-3/4"	10 x 1-1/8 x 1-3/4	1-1/8"	1-3/4"
18 x 1-1/4 x 1-7/8	1-1/4"	1-7/8"	14 x 1-1/4 x 1-7/8	1-1/4"	1-7/8"	10 x 1-1/4 x 1-7/8	1-1/4"	1-7/8"
18 x 1-3/8 x 2-1/8	1-3/8"	2-1/8"	14 x 1-3/8 x 2-1/8	1-3/8"	2-1/8"	10 x 1-3/8 x 2-1/8	1-3/8"	2-1/8"
18 x 1-1/2 x 2-1/4	1-1/2"	2-1/4"	14 x 1-1/2 x 2-1/4	1-1/2"	2-1/4"	10 x 1-1/2 x 2-1/4	1-1/2"	2-1/4"
18 x 1-5/8 x 2-3/8	1-5/8"	2-3/8"	14 x 1-5/8 x 2-3/8	1-5/8"	2-3/8"	10 x 1-5/8 x 2-3/8	1-5/8"	2-3/8"
18 x 1-3/4 x 2-1/2	1-3/4"	2-1/2"	14 x 1-3/4 x 2-1/2	1-3/4"	2-1/2"	10 x 1-3/4 x 2-1/2	1-3/4"	2-1/2"
18 x 1-7/8 x 2-7/8	1-7/8"	2-7/8"	14 x 1-7/8 x 2-7/8	1-7/8"	2-7/8"	10 x 1-7/8 x 2-7/8	1-7/8"	2-7/8"
18 x 2 x 3	2"	3"	14 x 2 x 3	2"	3"	10 x 2 x 3	2"	3"
18 x 2-1/8 x 3-1/8	2-1/8"	3-1/8"	14 x 2-1/8 x 3-1/8	2-1/8"	3-1/8"	10 x 2-1/8 x 3-1/8	2-1/8"	3-1/8"
18 x 2-1/4 x 3-1/4	2-1/4"	3-1/4"	14 x 2-1/4 x 3-1/4	2-1/4"	3-1/4"	10 x 2-1/4 x 3-1/4	2-1/4"	3-1/4"
18 x 2-3/8 x 3-3/8	2-3/8"	3-3/8"	14 x 2-3/8 x 3-3/8	2-3/8"	3-3/8"	10 x 2-3/8 x 3-3/8	2-3/8"	3-3/8"
18 x 2-1/2 x 3-1/2	2-1/2"	3-1/2"	14 x 2-1/2 x 3-1/2	2-1/2"	3-1/2"	10 x 2-1/2 x 3-1/2	2-1/2"	3-1/2"

# 2 Size Machine bushings ASTM F844								
18 GA. .042-.054	ID	OD	14 GA. .068-.082	ID	OD	10 GA. .126-.142	ID	OD
18 x 5/8 x 1-1/4	5/8"	1-1/4"	14 x 5/8 x 1-1/4	5/8"	1-1/4"	10 x 5/8 x 1-1/4	5/8"	1-1/4"
18 x 3/4 x 1-1/2	3/4"	1-1/2"	14 x 3/4 x 1-1/2	3/4"	1-1/2"	10 x 3/4 x 1-1/2	3/4"	1-1/2"
18 x 7/8 x 1-3/4	7/8"	1-3/4"	14 x 7/8 x 1-3/4	7/8"	1-3/4"	10 x 7/8 x 1-3/4	7/8"	1-3/4"
18 x 15/16 x 1-7/8	15/16"	1-7/8"	14 x 15/16 x 1-7/8	15/16"	1-7/8"	10 x 15/16 x 1-7/8	15/16"	1-7/8"
18 x 1 x 2	1"	2"	14 x 1 x 2	1"	2"	10 x 1 x 2	1"	2"
18 x 1-1/16 x 2-1/16	1-1/16"	2-1/16"	14 x 1-1/16 x 2-1/16	1-1/16"	2-1/16"	10 x 1-1/16 x 2-1/16	1-1/16"	2-1/16"
18 x 1-1/8 x 2-1/8	1-1/8"	2-1/8"	14 x 1-1/8 x 2-1/8	1-1/8"	2-1/8"	10 x 1-1/8 x 2-1/8	1-1/8"	2-1/8"
18 x 1-1/4 x 2-1/4	1-1/4"	2-1/4"	14 x 1-1/4 x 2-1/4	1-1/4"	2-1/4"	10 x 1-1/4 x 2-1/4	1-1/4"	2-1/4"
18 x 1-3/8 x 2-1/2	1-3/8"	2-1/2"	14 x 1-3/8 x 2-1/2	1-3/8"	2-1/2"	10 x 1-3/8 x 2-1/2	1-3/8"	2-1/2"
18 x 1-1/2 x 3	1-1/2"	3"	14 x 1-1/2 x 3	1-1/2"	3"	10 x 1-1/2 x 3	1-1/2"	3"
18 x 1-5/8 x 3-1/8	1-5/8"	3-1/8"	14 x 1-5/8 x 3-1/8	1-5/8"	3-1/8"	10 x 1-5/8 x 3-1/8	1-5/8"	3-1/8"
18 x 1-3/4 x 3-1/4	1-3/4"	3-1/4"	14 x 1-3/4 x 3-1/4	1-3/4"	3-1/4"	10 x 1-3/4 x 3-1/4	1-3/4"	3-1/4"
18 x 1-7/8 x 3-3/8	1-7/8"	3-3/8"	14 x 1-7/8 x 3-3/8	1-7/8"	3-3/8"	10 x 1-7/8 x 3-3/8	1-7/8"	3-3/8"
18 x 2 x 3-1/2	2"	3-1/2"	14 x 2 x 3-1/2	2"	3-1/2"	10 x 2 x 3-1/2	2"	3-1/2"
18 x 2-1/8 x 3-5/8	2-1/8"	3-5/8"	14 x 2-1/8 x 3-5/8	2-1/8"	3-5/8"	10 x 2-1/8 x 3-5/8	2-1/8"	3-5/8"
18 x 2-1/4 x 3-3/4	2-1/4"	3-3/4"	14 x 2-1/4 x 3-3/4	2-1/4"	3-3/4"	10 x 2-1/4 x 3-3/4	2-1/4"	3-3/4"
18 x 2-1/2 x 3-7/8	2-1/2"	3-7/8"	14 x 2-1/2 x 3-7/8	2-1/2"	3-7/8"	10 x 2-1/2 x 3-7/8	2-1/2"	3-7/8"
18 x 2-3/4 x 4	2-3/4"	4"	14 x 2-3/4 x 4	2-3/4"	4"	10 x 2-3/4 x 4	2-3/4"	4"
18 x 3 x 4-1/4	3"	4-1/4"	14 x 3 x 4-1/4	3"	4-1/4"	10 x 3 x 4-1/4	3"	4-1/4"

Extra Heavy Machine bushings ASTM F844		
3/16" Thickness	ID	OD
3/16 x 2 x 3	2"	3"
3/16 x 2-1/8 x 3-1/8	2-1/8"	3-1/8"
3/16 x 2-1/4 x 3-1/4	2-1/4"	3-1/4"
3/16 x 2-1/2 x 3-1/2	2-1/2"	3-1/2"
3/16 x 2-3/4 x 3-3/4	2-3/4"	3-3/4"
3/16 x 3 x 4	3"	4"

FOR MORE DETAILED INFORMATION, PLEASE REFER TO COMPLETE STANDARD WHICH IS THE GOVERNING STANDARD

ASTM F844 LFG 10/01/2016



ASME B18.27.1-NA1 / SAE-1070
Type SH External Retaining Rings



ASME B18.27.1-NA2 / SAE-1070
Type H0 Internal Retaining Rings



ASME B18.27.1-NA3 / SAE-1070
Type E Internal Reinforced Retaining Rings

Material & Finish: Carbon Steel SAE 1060 - 1090 - Black Phosphate Coated

Diameter	Shaft Dia. H	Groove Dia. G	Groove Width W	Free Dia. F	Thickness T	Shaft Dia. H	Groove Dia. G	Groove Width W	Free Dia. F	Thickness T	Shaft Dia. H	Groove Dia. G	Groove Width W	Free Dia. F	Thickness T
1/16											0.062	0.052	0.012	0.051	0.01
3/32											0.094	0.074	0.02	0.073	0.015
1/8											0.125	0.095	0.02	0.094	0.015
9/64											0.14	0.102	0.02	0.1	0.015
5/32											0.156	0.116	0.029	0.114	0.025
11/64											0.172	0.127	0.029	0.125	0.025
3/16											0.188	0.147	0.029	0.145	0.025
7/32											0.219	0.188	0.029	0.185	0.025
1/4	0.25	0.23	0.029	0.225	0.025	0.25	0.268	0.02	0.28	0.015	0.25	0.21	0.029	0.207	0.025
9/32	0.281	0.261	0.029	0.256	0.025	0.312	0.33	0.02	0.346	0.015					
5/16	0.312	0.29	0.029	0.281	0.025	0.375	0.397	0.029	0.415	0.025	0.312	0.25	0.029	0.243	0.025
11/32	0.344	0.321	0.029	0.309	0.025	0.438	0.461	0.029	0.482	0.025					
3/8	0.375	0.352	0.029	0.338	0.025	0.5	0.53	0.039	0.548	0.035	0.375	0.303	0.039	0.3	0.035
13/32	0.406	0.382	0.029	0.366	0.025	0.562	0.596	0.039	0.62	0.035					
7/16	0.438	0.412	0.029	0.395	0.025	0.625	0.665	0.039	0.694	0.035	0.438	0.343	0.039	0.337	0.035
1/2	0.5	0.468	0.039	0.461	0.035	0.688	0.732	0.039	0.763	0.035	0.5	0.396	0.046	0.392	0.042
9/16	0.562	0.53	0.039	0.521	0.035	0.75	0.796	0.039	0.831	0.035					
19/32	0.594	0.559	0.039	0.55	0.035	0.812	0.862	0.046	0.901	0.042					
5/8	0.625	0.588	0.039	0.579	0.035	0.875	0.931	0.046	0.971	0.042	0.625	0.485	0.046	0.48	0.042
11/16	0.688	0.646	0.046	0.635	0.042	0.938	1	0.046	1.041	0.042					
3/4	0.75	0.704	0.046	0.693	0.042	1	1.066	0.046	1.111	0.042	0.75	0.625	0.056	0.616	0.05
13/16	0.812	0.762	0.046	0.751	0.042	1.062	1.13	0.056	1.18	0.05					
7/8	0.875	0.821	0.046	0.81	0.042	1.125	1.197	0.056	1.249	0.05	0.875	0.675	0.056	0.668	0.05
15/16	0.938	0.882	0.046	0.867	0.042	1.188	1.262	0.056	1.319	0.05					
63/64											0.984	0.835	0.056	0.822	0.05
1	1	0.94	0.046	0.925	0.042	1.25	1.33	0.056	1.388	0.05					
1 1/16	1.062	0.998	0.056	0.982	0.05	1.312	1.396	0.056	1.456	0.05					
1-1/8	1.125	1.059	0.056	1.041	0.05	1.375	1.461	0.056	1.526	0.05					
1-3/16	1.188	1.118	0.056	1.098	0.05	1.438	1.528	0.056	1.596	0.05	1.188	1.079	0.068	1.066	0.062
1-1/4	1.25	1.176	0.056	1.156	0.05	1.5	1.594	0.056	1.66	0.05					
1-5/16	1.312	1.232	0.056	1.214	0.05	1.562	1.658	0.068	1.734	0.062					
1-3/8	1.375	1.291	0.056	1.272	0.05	1.625	1.725	0.068	1.804	0.062					
1-7/16	1.438	1.35	0.056	1.333	0.05	1.688	1.792	0.068	1.874	0.062					
1-1/2	1.5	1.406	0.056	1.387	0.05	1.75	1.858	0.068	1.942	0.062					
1-9/16	1.562	1.468	0.068	1.446	0.062	1.812	1.922	0.068	2.012	0.062					
1-5/8	1.625	1.529	0.068	1.503	0.062	1.875	1.989	0.068	2.072	0.062					
1-11/16	1.688	1.589	0.068	1.56	0.062	1.938	2.056	0.068	2.141	0.062					
1-3/4	1.75	1.65	0.068	1.618	0.062	2	2.122	0.068	2.21	0.062					
1-13/16	1.812	1.708	0.068	1.675	0.062	2.062	2.186	0.086	2.28	0.078					
1-7/8	1.875	1.769	0.068	1.735	0.062	2.125	2.251	0.086	2.35	0.078					
2	2	1.886	0.068	1.85	0.062	2.188	2.318	0.086	2.415	0.078					
2-1/16	2.062	1.946	0.086	1.906	0.078	2.25	2.382	0.086	2.49	0.078					
2-1/8	2.125	2.003	0.086	1.964	0.078	2.312	2.45	0.086	2.56	0.078					
2-1/4	2.25	2.12	0.086	2.081	0.078	2.375	2.517	0.086	2.63	0.078					
2-5/16	2.312	2.178	0.086	2.139	0.078	2.44	2.584	0.086	2.702	0.078					
2-3/8	2.375	2.239	0.086	2.197	0.078	2.5	2.648	0.086	2.775	0.078					
2-7/16	2.438	2.299	0.086	2.255	0.078	2.562	2.714	0.103	2.844	0.093					
2-1/2	2.5	2.36	0.086	2.313	0.078	2.625	2.781	0.103	2.91	0.093					
2-5/8	2.625	2.481	0.086	2.428	0.078	2.688	2.848	0.103	2.98	0.093					
2-11/16	2.688	2.541	0.086	2.485	0.078	2.75	2.914	0.103	3.05	0.093					
2-3/4	2.75	2.602	0.103	2.543	0.093	2.812	2.98	0.103	3.121	0.093					
2-7/8	2.875	2.721	0.103	2.659	0.093	2.875	3.051	0.103	3.191	0.093					
3	3	2.838	0.103	2.775	0.093	3	3.182	0.103	3.325	0.093					

DIMENSIONS ARE TO ASME B18.27.1 RETAINING RINGS ARE A COMPONENT OF THAT STANDARD, BUT IT IS NO LONGER WIDELY RECOGNIZED BY THE INDUSTRY. INSTEAD THE MILITARY SPECIFICATION IS NORMALLY USED TO SPECIFY RETAINING RINGS

ASME B18.27.1 - NA1 - NA2 - NA3 (DIMENSIONS ONLY) - LFG 10/01/2016

INCH TRILOBULAR THREAD FORMING SCREWS

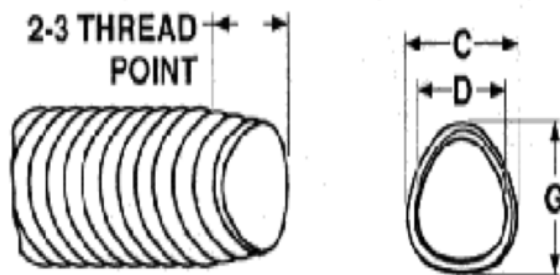

16.1 - INCH TRILOBULAR THREAD FORMING SCREWS

Nominal Screw Width	C		D		G
	Screw Body Dimensions				
	Diameter of Circumscribing Circle		Measurement Across Center		Point Diameter of Circumscribing Circle
	Max	Min	Max	Min	Max
2-56	.0875	.0835	.0840	.0800	.070
3-48	.1010	.0970	.0970	.0930	.081
4-40	.1145	.1105	.1095	.1055-.1185	.090
5-40	.1275	.1235	.1225	.1185	.103
6-32	.1410	.1350	.1350	.1290	.111
8-32	.1670	.1610	.1610	.1550	.137
10-24	.1940	.1880	.1860	.1800	.153
10-32	.1930	.1870	.1870	.1810	.163
12-24	.2200	.2140	.2120	.2060	.179
1/4-20	.2550	.2490	.2450	.2390	.206
5/16-18	.3180	.3120	.307	.301	.264
3/8-16	.3810	.3750	.3685	.3625	.320
1/2-13	.5075	.5015	.4920	.4860	.432

Tolerance on Length	Nominal Screw Size	Nominal Screw Length		
		To 3/4" Incl.	Over 3/4" to 1.5" Incl.	Over 1.5"
	All Diameters	-0.03	-0.05	-0.06

Description Trilobular thread forming screw. Each lobe of the screw moves thru the hole in the parent material forming and hardening the nut thread metal creating uninterrupted grain flow.

Applications For drilled or punched holes in ductile metal and punch extruded metal. Provides resistance to vibrational looser demands lower drive in torque and eliminates chips.

	Steel	Stainless Steel
Materials	Cold-heading steel conforming to a chemical composition: Carbon: 0.13-.027%; Manganese: 0.64-1.71%	18-8 Stainless steel 410 austenitic stainless steel
Heat Treatment	Quenched in liquid and then reheated to temper at 650°F minimum.	410: to be annealed by heating to 1850° - 1950°F, held for at least 1/2 hour & oil quenched or rapid air; then reheated to 525°F minimum for at least 1 hour & air cooled to provide the required mechanical properties.
Case Hardness	Rockwell C45 Minimum	-
Case Depth	2-56 through 6-32 diameter: .002 - .007 8-32 through 12-24 diameter: .004 - .009 1/4-20 diameter and larger: .005 - .011	-
Core Hardness after tempering	Rockwell C28 - 38	18-8: Rockwell B90 - C20 410: Rockwell C34 - 42
Plating	Contact Lindstrom for plating options	Stainless Steel screws are passivated and waxed.

LFG 10/01/2016



Get quote »

Angic Global Solutions

1-888-872-0690 Rights Reserved

<https://www.AngicGlobal.com> Sales@AngicGlobal.com

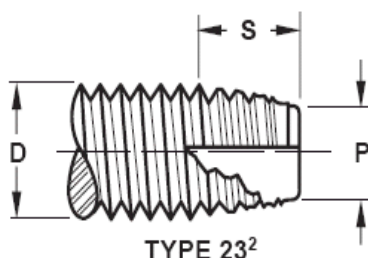

TYPE 23²

Nominal Size Screw Diameter	Threads Per Inch	D		P	S				L				Min. Torsional Strength, lb.- in. (Steel Only)	
		Major Diameter		Point Diameter	Point Taper Length				Determinant Length for Point Taper		Minimum Practical Screw Lengths			
		Max	Min	Ref	Short Screws		Long Screws		90° Heads	Csk Heads	90° Heads	Csk Heads		
2	.0860	56	.0860	.0813	.068	.062	.045	.080	.062	5/32	3/16	5/32	3/16	5
3	.0990	48	.0990	.0938	.078	.073	.052	.094	.073	3/16	7/32	5/32	7/32	9
4	.1120	40	.1120	.1061	.087	.088	.062	.112	.088	7/32	1/4	3/16	1/4	13
5	.1250	40	.1250	.1191	.100	.088	.062	.112	.088	7/32	9/32	3/16	1/4	18
6	.1380	32	.1380	.1312	.107	.109	.078	.141	.109	1/4	5/16	1/4	5/16	23
8	.1640	32	.1640	.1571	.132	.109	.078	.141	.109	1/4	11/32	1/4	5/16	42
10	.1900	24	.1900	.1818	.148	.146	.104	.188	.146	11/32	7/16	5/16	13/32	56
10	.1900	32	.1900	.1831	.158	.109	.078	.141	.109	1/4	11/32	1/4	5/16	74
12	.2160	24	.2160	.2078	.174	.146	.104	.188	.146	11/32	7/16	5/16	13/32	93
1/4	.2500	20	.2500	.2408	.200	.175	.125	.225	.175	13/32	177/32	3/8	1/2	140
5/16	.3125	18	.3125	.3026	.257	.194	.139	.250	.194	15/32	19/32	7/16	9/16	306
3/8	.3750	18	.3750	.3643	.312	.219	.156	.281	.219	1/2	11/16	15/32	5/8	560
Tolerance on Length		Up to 3/4" incl.: -0.03				Over 3/4" to 1-1/2" incl.: -0.05				Over 1-1/2": -0.06				
Description	Thread cutting screws with a machine screw thread pitch with a blunt point. Tapered lead threads and single cutting edge with a chip cavity.													
Applications	Steel Type 23 thread cutting screws are utilized in zinc, aluminum and cast iron die castings as well as plastic. They provide strong chip clearing and low tightening torques. Stainless steel add resistance to corrosion. Thread cutting screws should be used in materials that have a lower Rockwell hardness by 10 - 20 points.													
Material	Steel: AISI 1016 - 1024 or equivalent. Stainless: 18-8 stainless steel.													
Heat Treatment	Steel: To be quenched in liquid and the reheated for tempering to 650° minimum.													
Surface Hardness	Steel: Rockwell C45 minimum													
Case Depth for Steel	No. 2 thru 6 diameter: .002 - .007 No. 8 thru 12 diameter: .004 - .009 1/4" & larger diameter: .005 - .011													
Core Hardness	Steel after tempering: Rockwell C28 - 38 Stainless: Rockwell B90 - C20													
Plating	Contact Lindstrom for plating options.													

16.2 - INCH TYPE 23 THREAD CUTTING SCREWS



INCH TYPE 25 THREAD CUTTING SCREWS

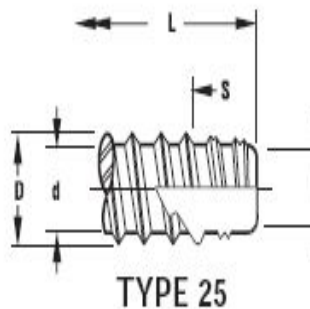

TYPE 25

Nominal Size or Basic Screw Diameter	Threads Per Inch	D		d		P	S		L		Minimum Torsional Strength, lb. -in. (Steel only)	
		Major Diameter		Minor Diameter		Point Diameter	Point Taper Length		Minimum Practical Length			
		Max	Min	Max	Min	Ref	Max	Min	90° Heads	Csk Heads		
2	.0860	32	.088	.082	.064	.060	.058	.062	.047	5/32	3/16	4
4	.1120	24	.114	.108	.086	.082	.079	.083	.063	3/16	1/4	13
5	.1250	20	.130	.123	.094	.090	.087	.100	.075	7/32	9/32	18
6	.1380	20	.139	.132	.104	.099	.095	.100	.075	1/4	9/32	24
7	.1510	19	.154	.147	.115	.109	.105	.105	.079	1/4	5/16	30
8	.1640	18	.166	.159	.122	.116	.112	.111	.083	9/32	11/32	39
10	.1900	16	.189	.182	.141	.135	.130	.125	.094	5/16	3/8	56
12	.2160	14	.215	.208	.164	.157	.152	.143	.107	11/32	7/16	88
1/4	.2500	14	.246	.237	.192	.185	.179	.143	.107	3/8	1/2	142
5/16	.3125	12	.315	.306	.244	.236	.230	.167	.125	15/32	19/32	290
3/8	.3750	12	.380	.371	.309	.299	.293	.167	.125	17/32	11/16	590
Tolerance on Length		Up to 3/4" Incl.: -.03					Over 3/4" to 1-1/2" Incl.: -.05					

Description	Thread cutting Screw with thread spaced apart, a blunt point with tapered lead threads, a single wide cutting edge and chip cavity.	
Application	For through holes or molded holes in plastic and other like soft materials. Excellent chip cleaning capability.	Stainless steel screws add resistance to corrosion. Thread cutting screws should be used in materials that have a lower Rockwell hardness by 10 - 20 points.
Material	AISI 1016 - 1024 or equivalent.	18-8 Stainless Steel
Heat Treatment	To be quenched in liquid and the reheated for tempering to 650° minimum.	-
Surface Hardness	Rockwell C45 minimum	-
Case Depth	No. 4 thru 6 diameter: .002 - .007 No. 8 thru 10 diameter: .004 - .009 1/4" & larger diameter: .005 - .011	-
Core Hardness after tempering	Rockwell C28 - 38	Rockwell B90 - C20
Plating	Contact Lindstrom for plating options.	

LFG 10/01/2016

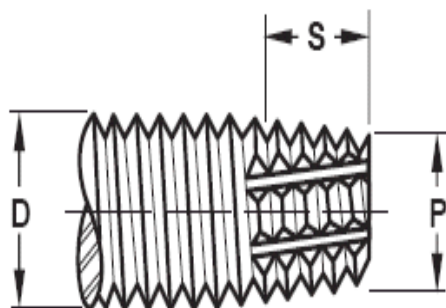

TYPE F

Nominal Size Screw Diameter	Threads Per Inch	D		P	S				L				Min. Torsional Strength, lb.-in. (Steel Only)	
		Major Diameter		Point Diameter	Point Taper Length				Determinant Length for Point Taper		Minimum Practical Screw Lengths			
		Max	Min	Ref	Max	Min	Max	Min	90° Heads	Csk Heads	90° Heads	Csk Heads		
2	.0860	56	.0860	.0813	.068	.062	.045	.080	.062	5/32	3/16	5/32	3/16	5
4	.1120	40	.1120	.1061	.087	.088	.062	.112	.088	7/32	1/4	3/16	1/4	13
5	.1250	40	.1250	.1191	.100	.088	.062	.112	.088	7/32	9/32	3/16	1/4	18
6	.1380	32	.1380	.1312	.107	.109	.078	.141	.109	1/4	5/16	1/4	5/16	23
8	.1640	32	.1640	.1571	.132	.109	.078	.141	.109	1/4	11/32	1/4	5/16	42
10	.1900	24	.1900	.1818	.148	.146	.104	.188	.146	11/32	7/16	5/16	13/32	56
10	.1900	32	.1900	.1831	.158	.109	.078	.141	.109	1/4	11/32	1/4	5/16	74
12	.2160	24	.2160	.2078	.174	.146	.104	.188	.146	11/32	7/16	5/16	13/32	93
1/4	.2500	20	.2500	.2408	.200	.175	.125	.225	.175	13/32	17/32	3/8	1/2	140
5/16	.3125	18	.3125	.3026	.257	.194	.139	.250	.194	15/32	19/32	7/16	9/16	306
3/8	.3750	16	.3750	.3643	.312	.219	.156	.281	.219	1/2	11/16	15/32	5/8	560
1/2	.5000	13	.5000	.4876	.423	.269	.192	.346	.269	5/8	25/32	19/32	3/4	1075

Tolerance on Length	Up to 3/4" incl.: -0.03	Over 3/4" to 1-1/2" incl.: -0.05	Over 1-1/2": -0.06
Description	Thread cutting screws with a machine screw thread pitch with a blunt point. Tapered lead threads and several cutting edges.		
Applications	Steel thread cutting screws are utilized in heavy gauge sheet metal, zinc, aluminum and lead die casting, brass, plastic and cast iron. Stainless screws add resistance to corrosion. Thread cutting screws should be used in materials that have a lower Rockwell hardness by 10 - 20 points.		
Material	Steel: AISI 1016 - 1024 or equivalent. Stainless: 410 martensitic stainless steel or 18*8 stainless steel.		
Heat Treatment	Steel: To be quenched in liquid and the reheated for tempering to 650° minimum. 410 Stainless Steel: To be annealed by heating to 1850° - 1950° F, held for a minimum of 30 minutes and oil or rapid air quenched then reheated to 525° minimum for at least 60 minutes and then air cooled to reach the required tensile, hardness and yield properties.		
Case Depth for Steel	No. 4 thru 6 diameter: .002 - .007 No. 8 thru 12 diameter: .004 - .009 1/4" & larger diameter: .005 - .011		
Hardness	Steel Surface Hardness: Rockwell C45 minimum; Steel Core Hardness (after tempering): Rockwell C28 - 38 410 Stainless: Rockwell C38 - 42 18-8 Stainless: Rockwell B90 - C20		
Plating	Contact Lindstrom for plating options.		

16.4 - INCH TYPE F THREAD CUTTING SCREWS



INCH PAN HEAD - HEAD / DRIVE ■ ASME B18 6 3

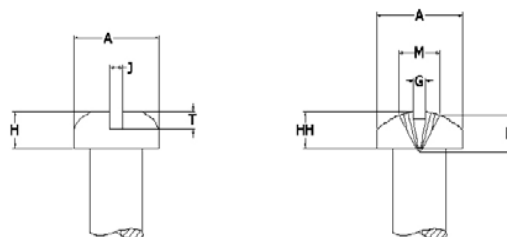

Size	A		H		HH		J		T		M		N	G	Phillips Driver Bit size
	Diameter of Head		Head Height				Slot Width		Slot Depth		Recess Dimension				
			Slotted		Recessed						Diameter		Depth	Width	
	Min.	Max.	Min.	Max.	Min.	Max.	Min.	Max.	Min.	Max.	Min.	Max.	Max.	Min.	
2	0.155	0.167	0.045	0.053	0.053	0.062	0.023	0.031	0.022	0.031	0.091	0.104	0.059	0.017	1
3	0.180	0.193	0.051	0.060	0.062	0.071	0.027	0.035	0.026	0.036	0.099	0.112	0.068	0.019	1
4	0.205	0.219	0.058	0.068	0.070	0.080	0.031	0.039	0.030	0.040	0.109	0.122	0.078	0.019	1
5	0.231	0.245	0.065	0.075	0.079	0.089	0.035	0.043	0.034	0.045	0.145	0.158	0.083	0.028	2
6	0.256	0.270	0.072	0.082	0.087	0.097	0.039	0.048	0.037	0.050	0.153	0.166	0.091	0.028	2
7	0.281	0.296	0.079	0.089	0.096	0.106	0.039	0.048	0.041	0.054	0.163	0.176	0.100	0.029	2
8	0.306	0.322	0.085	0.096	0.105	0.115	0.045	0.054	0.045	0.058	0.169	0.182	0.108	0.030	2
10	0.357	0.373	0.099	0.110	0.122	0.133	0.050	0.060	0.053	0.068	0.186	0.199	0.124	0.031	2
12	0.407	0.425	0.112	0.125	0.139	0.151	0.056	0.067	0.061	0.077	0.246	0.259	0.141	0.034	3
1/4	0.473	0.492	0.130	0.144	0.162	0.175	0.064	0.075	0.070	0.087	0.268	0.281	0.161	0.036	3
5/16	0.594	0.615	0.162	0.178	0.203	0.218	0.072	0.084	0.085	0.106	0.337	0.350	0.193	0.059	4
3/8	0.716	0.740	0.195	0.212	0.244	0.261	0.081	0.094	0.100	0.124	0.376	0.389	0.233	0.065	4

INCH TRUSS HEAD - HEAD / DRIVE ■ ASME B18 6 3

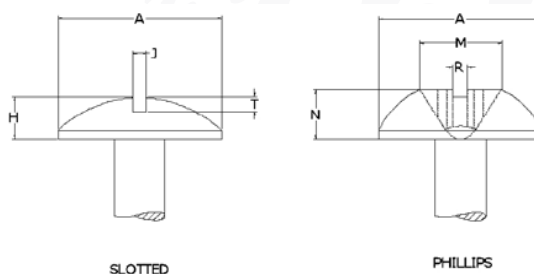

Size	A		H		T		J		M		R	N	Phillips Driver Bit Size
	Head Diameter		Head Height		Slot Depth		Slot Width		Recess Dimension				
									Diameter		Width	Depth	
	Min.	Max.	Min.	Max.	Min.	Max.	Min.	Max.	Min.	Max.	Min.	Max.	
4	0.241	0.257	0.059	0.069	0.030	0.040	0.031	0.039	0.099	0.112	0.018	0.069	1
6	0.303	0.321	0.074	0.086	0.037	0.050	0.039	0.048	0.145	0.158	0.027	0.084	2
8	0.364	0.384	0.088	0.102	0.045	0.058	0.045	0.054	0.016	0.173	0.029	0.099	2
10	0.425	0.448	0.103	0.118	0.053	0.068	0.050	0.060	0.175	0.188	0.030	0.115	2
12	0.487	0.511	0.118	0.134	0.061	0.077	0.056	0.067	0.235	0.248	0.032	0.128	3
1/4	0.546	0.573	0.133	0.150	0.070	0.087	0.064	0.075	0.250	0.263	0.033	0.143	3
5/16	0.666	0.698	0.162	0.183	0.085	0.106	0.072	0.084	0.339	0.352	0.059	0.193	4
3/8	0.787	0.823	0.191	0.215	0.100	0.124	0.081	0.094	0.370	0.383	0.063	0.226	4

FOR MORE DETAILED INFORMATION, PLEASE REFER TO COMPLETE ASME STANDARD, WHICH IS THE GOVERNING STANDARD

ASME B18.6.3 (2013) LFG 10/01/2016

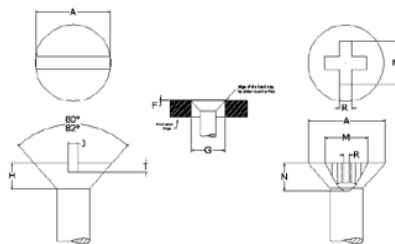

Size	Lengths Below or Shorter Are Undercut		a		H		J		T		N	R	M	F		G	Phillips Driver Bit Size
			Dimensions of Head				Dimensions of Slot				Dimensions of Phillips			Protrusion Above Gaging		Diameter of Gaging	
	Other Types	Types A & AB	Diameter		Height		Width		Depth		Depth	Width	Diameter	Min.	Max.		
			Min.	Max.	Min.	Max.	Min.	Max.	Min.	Max.	Ref.	Ref.	Ref.				
0	1/8	3/16	0.096	0.112	0.026	0.035	0.016	0.023	0.010	0.015	0.035	0.014	0.062	0.016	0.026	0.078	0
1	5/32	3/16	0.120	0.137	0.033	0.043	0.019	0.026	0.012	0.019	0.043	0.015	0.070	0.016	0.028	0.101	0
2	3/16	3/16	0.144	0.162	0.040	0.051	0.023	0.031	0.015	0.023	0.055	0.017	0.096	0.017	0.029	0.124	1
4	1/4	1/4	0.191	0.212	0.055	0.067	0.031	0.039	0.020	0.030	0.081	0.018	0.122	0.019	0.032	0.172	1
5	1/4	1/4	0.215	0.237	0.062	0.075	0.035	0.043	0.022	0.034	0.074	0.027	0.148	0.020	0.034	0.196	2
6	5/16	5/16	0.238	0.262	0.069	0.083	0.039	0.048	0.024	0.038	0.094	0.029	0.168	0.021	0.036	0.220	2
8	3/8	3/8	0.262	0.287	0.076	0.091	0.039	0.048	0.027	0.041	0.102	0.030	0.176	0.022	0.037	0.243	2
7	7/16	7/16	0.285	0.312	0.084	0.100	0.045	0.054	0.029	0.045	0.110	0.030	0.182	0.023	0.039	0.267	2
10	1/2	1/2	0.333	0.362	0.098	0.116	0.050	0.060	0.034	0.053	0.124	0.032	0.198	0.025	0.042	0.313	2
12	9/16	9/16	0.380	0.412	0.112	0.132	0.056	0.067	0.039	0.060	0.144	0.035	0.262	0.027	0.045	0.362	3
14	N/A	5/8	0.427	0.462	0.126	0.148	0.064	0.075	0.044	0.068	0.160	0.036	0.276	0.029	0.049	0.410	3
1/4	5/8	5/8	0.442	0.477	0.131	0.153	0.064	0.075	0.046	0.070	0.160	0.036	0.276	0.029	0.050	0.424	3
5/16	5/8	13/16	0.556	0.597	0.165	0.191	0.072	0.084	0.058	0.088	0.205	0.061	0.358	0.034	0.057	0.539	4
3/8	5/8	N/A	0.670	0.717	0.200	0.230	0.081	0.094	0.070	0.106	0.234	0.065	0.386	0.039	0.065	0.653	4

16.6 - INCH FLAT HEAD SCREWS

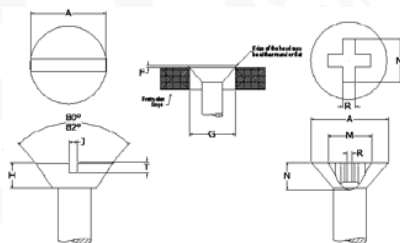

Size	Lengths Below or Shorter Are Undercut		A		H		J		T		N	R	M	F		G	Phillips Driver Bit Size
			Dimensions of Head				Dimensions of Slot				Dimensions of Phillips			Protrusion Above Gaging		Diameter of Gaging	
	Other Types	Types A & AB	Diameter		Height		Width		Depth		Depth	Width	Diameter	Min.	Max.		
			Min.	Max.	Min.	Max.	Min.	Max.	Min.	Max.	Ref.	Ref.	Ref.				
0	1/8	3/16	0.096	0.120	0.018	0.025	0.016	0.023	0.007	0.011	0.035	0.014	0.062	N/A	N/A	N/A	0
1	5/32	3/16	0.120	0.137	0.023	0.031	0.019	0.026	0.009	0.014	0.043	0.015	0.070	N/A	N/A	N/A	0
2	3/16	3/16	0.144	0.162	0.028	0.036	0.023	0.031	0.011	0.016	0.048	0.017	0.088	0.017	0.029	0.124	1
4	1/4	1/4	0.191	0.212	0.038	0.047	0.031	0.039	0.014	0.022	0.070	0.018	0.110	0.019	0.032	0.172	1
6	5/16	5/16	0.238	0.262	0.048	0.059	0.039	0.048	0.017	0.027	0.066	0.025	0.140	0.021	0.036	0.220	2
7	3/8	3/8	0.262	0.287	0.053	0.064	0.039	0.048	0.019	0.030	0.074	0.027	0.148	0.022	0.037	0.243	2
8	7/16	7/16	0.285	0.312	0.058	0.070	0.045	0.054	0.021	0.032	0.094	0.029	0.168	0.023	0.039	0.267	2
10	1/2	1/2	0.333	0.362	0.068	0.081	0.050	0.060	0.024	0.037	0.110	0.030	0.182	0.025	0.042	0.313	2
12	9/16	9/16	0.380	0.412	0.078	0.092	0.056	0.067	0.028	0.043	0.110	0.030	0.226	0.027	0.045	0.362	3
1/4	5/8	5/8	0.442	0.477	0.092	0.107	0.064	0.075	0.032	0.050	0.124	0.032	0.244	0.029	0.050	0.424	3
5/16	5/8	13/16	0.556	0.597	0.116	0.134	0.072	0.084	0.041	0.062	0.157	0.053	0.310	0.034	0.057	0.539	4
3/8	5/8	N/A	0.670	0.717	0.140	0.161	0.081	0.094	0.049	0.075	0.205	0.061	0.358	0.039	0.065	0.653	4

FOR MORE DETAILED INFORMATION, PLEASE REFER TO COMPLETE ASME STANDARD, WHICH IS THE GOVERNING STANDARD

ASME B18.6.3 (2013) LFG 10/01/2016



INCH HEX HEAD AND HEX WASHER HEAD - HEAD / DRIVE - ASME B18 6 3

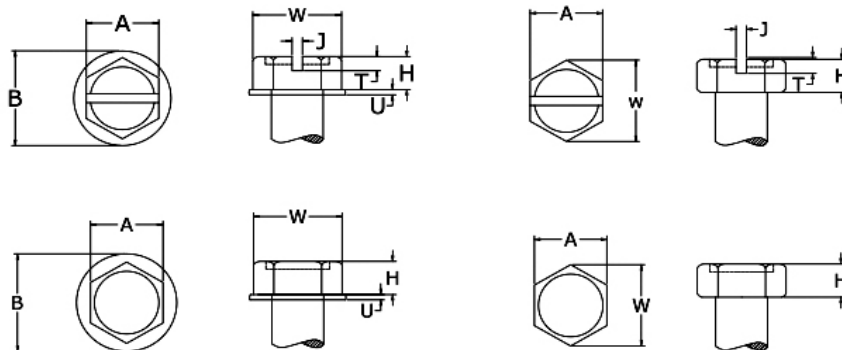

Size	A		W	H		B		U		T		J	
	Width Across Flats			Width A/C	Head Height		Washer Dimensions		Washer Thickness		Depth of Slot		Width of Slot
	Min.	Max.	Min.		Min.	Max.	Min.	Max.	Min.	Max.	Min.	Max.	Min.
4	0.181	0.188	0.202	0.049	0.060	0.225	0.243	0.011	0.019	0.025	0.036	0.031	0.039
6	0.244	0.250	0.272	0.080	0.093	0.302	0.328	0.015	0.025	0.033	0.046	0.039	0.048
7	0.244	0.250	0.272	0.080	0.093	0.302	0.328	0.017	0.029	0.040	0.054	0.039	0.048
8	0.244	0.250	0.272	0.096	0.110	0.322	0.348	0.019	0.031	0.052	0.066	0.045	0.054
10	0.305	0.312	0.340	0.105	0.120	0.384	0.414	0.019	0.031	0.057	0.072	0.050	0.060
12	0.305	0.312	0.340	0.139	0.155	0.398	0.432	0.022	0.039	0.077	0.093	0.056	0.067
14	0.367	0.375	0.409	0.172	0.190	0.480	0.520	0.030	0.050	0.083	0.101	0.064	0.075
1/4	0.367	0.375	0.409	0.172	0.190	0.480	0.520	0.030	0.050	0.083	0.101	0.064	0.075
5/16	0.489	0.500	0.545	0.208	0.230	0.624	0.676	0.035	0.055	0.100	0.122	0.072	0.084
3/8	0.551	0.562	0.614	0.270	0.295	0.720	0.780	0.037	0.063	0.131	0.156	0.081	0.094

INCH COMBO HEAD (PHILLIPS AND SLOTTED) - HEAD / DRIVE - ASME B18 6 3

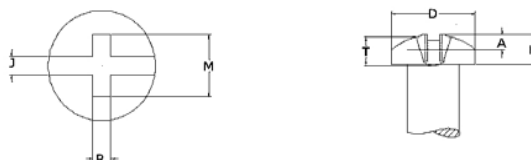

Size	D	H	A		J		T		M		N	Recess Penetration		Driver Bit Size		
	Head Dimension		Slot Dimensions				Recess Dimensions									
	Head Diameter		Head Height		Slot Depth		Slot Width		Depth		Diameter				Width	
	Min.	Max.	Min.	Max.	Min.	Max.	Min.	Max.	Min.	Max.	Min.	Max.	Ref.		Min.	Max.
4	0.205	0.219	0.070	0.080	0.030	0.040	0.031	0.039	0.060	0.078	0.109	0.122	0.019	0.053	0.071	1
6	0.256	0.270	0.087	0.097	0.037	0.050	0.039	0.048	0.066	0.091	0.153	0.166	0.028	0.055	0.080	2
7	0.281	0.296	0.096	0.106	0.041	0.054	0.039	0.048	0.074	0.100	0.163	0.176	0.029	0.064	0.089	2
8	0.306	0.322	0.105	0.115	0.045	0.058	0.045	0.054	0.082	0.108	0.169	0.182	0.030	0.071	0.097	2
10	0.357	0.373	0.122	0.133	0.053	0.068	0.050	0.060	0.100	0.124	0.186	0.199	0.031	0.089	0.113	2
12	0.407	0.425	0.139	0.151	0.061	0.077	0.056	0.067	0.115	0.141	0.246	0.259	0.034	0.098	0.124	3
1/4	0.473	0.492	0.162	0.175	0.070	0.087	0.064	0.075	0.135	0.161	0.268	0.281	0.036	0.118	0.144	3

FOR MORE DETAILED INFORMATION, PLEASE REFER TO COMPLETE ASME STANDARD, WHICH IS THE GOVERNING STANDARD

ASME B18.6.3 (2013) LFG 10/01/2016

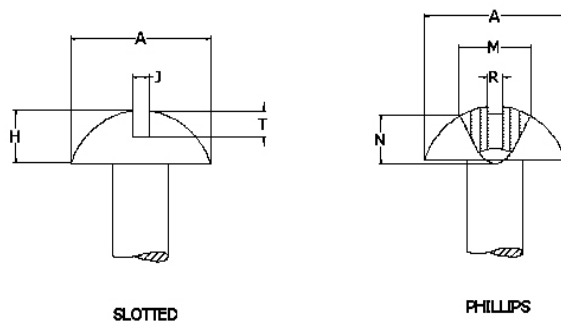

Size	A		H		T		J		N	R	M	Recess Penetration		Phillips Driver Bit Size
	Head Diameter		Head Height		Slot Depth		Slot Width		Recess Dimensions			Min.	Max.	
	Min.	Max.	Min.	Max.	Min.	Max.	Min.	Max.	Depth	Width	Diameter			
									Ref.	Ref.	Ref.			
4	0.193	0.211	0.075	0.086	0.044	0.058	0.031	0.039	0.062	0.019	0.112	0.046	0.065	1
6	0.240	0.260	0.091	0.103	0.051	0.068	0.039	0.048	0.070	0.027	0.156	0.045	0.073	2
8	0.287	0.309	0.107	0.120	0.058	0.077	0.045	0.054	0.088	0.030	0.172	0.064	0.090	2
10	0.334	0.359	0.123	0.137	0.065	0.087	0.050	0.060	0.106	0.031	0.188	0.082	0.108	2
12	0.382	0.408	0.139	0.153	0.073	0.096	0.056	0.067	0.112	0.032	0.242	0.082	0.108	3
1/4	0.443	0.472	0.160	0.175	0.082	0.109	0.064	0.075	0.134	0.034	0.262	0.104	0.130	3

INCH ROUND WASHER HEAD - HEAD / DRIVE SCREWS ▪ ASME B18 6 3

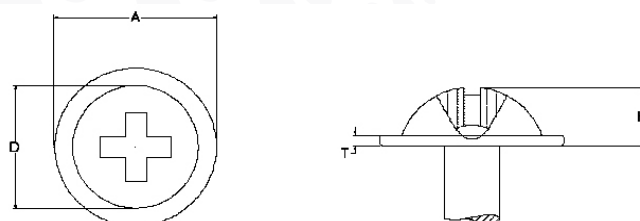

Size	D	H		A		T		Recess Penetration		Phillips Driver Bit Size
	Outside Head Diameter	Head Height (Overall)		Outside Washer Diameter		Washer Thickness		Min.	Max.	
	Ref.	Min.	Max.	Min.	Max.	Min.	Max.			
8	0.288	0.116	0.128	0.365	0.385	0.030	0.041	0.064	0.090	2
10	0.351	0.123	0.137	0.418	0.441	0.033	0.047	0.082	0.108	2

FOR MORE DETAILED INFORMATION, PLEASE REFER TO COMPLETE ASME STANDARD, WHICH IS THE GOVERNING STANDARD

ASME B18.6.3 (2013) LFG 10/01/2016

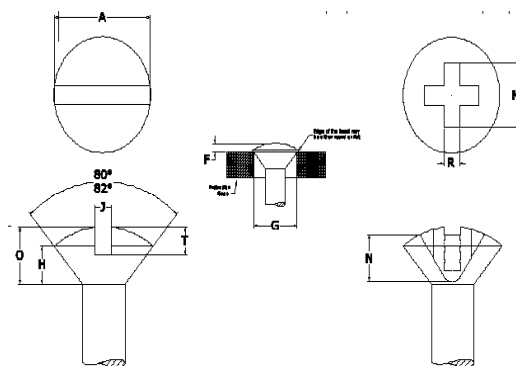

Size	These Lengths and Shorter are Undercut		A		H	O	T	J	N	R	M	F		G	Phillips Driver Bit Size		
			Diameter of Head									Protrusion Above Gaging					
	Other Types	Type A & AB	Min.	Max.	Head Height		Slot Depth		Recess Dimensions			Protrusion Above Gaging					
					Side	Total	Min.	Max.	Depth	Width	Diameter	Min.	Max.				
				Max.	Max.	Min.	Max.	Min.	Max.	Ref.	Ref.	Ref.	Min.	Max.	Gaging diameter		
0	1/8	3/16	0.096	0.112	0.035	0.056	0.025	0.030	0.016	0.023	0.036	0.014	0.068	0.047	0.031	0.078	0
1	5/32	3/16	0.120	0.137	0.043	0.068	0.031	0.038	0.019	0.026	0.039	0.015	0.070	0.053	0.035	0.101	0
2	3/16	3/16	0.144	0.162	0.051	0.080	0.037	0.045	0.023	0.031	0.060	0.018	0.106	0.058	0.039	0.124	1
3	7/32	7/32	0.167	0.187	0.059	0.092	0.043	0.052	0.027	0.035	0.072	0.019	0.118	0.064	0.044	0.148	1
4	1/4	1/4	0.191	0.212	0.067	0.104	0.049	0.059	0.031	0.039	0.086	0.019	0.130	0.069	0.048	0.172	1
5	1/4	1/4	0.215	0.237	0.075	0.116	0.055	0.067	0.035	0.043	0.073	0.028	0.152	0.075	0.053	0.196	2
6	5/16	5/16	0.238	0.262	0.083	0.128	0.060	0.074	0.039	0.048	0.092	0.030	0.172	0.080	0.057	0.220	2
8	3/8	3/8	0.285	0.312	0.100	0.152	0.072	0.088	0.045	0.054	0.107	0.031	0.186	0.091	0.066	0.267	2
10	7/16	7/16	0.333	0.362	0.116	0.176	0.084	0.103	0.050	0.060	0.125	0.033	0.202	0.102	0.075	0.313	2
12	1/2	1/2	0.380	0.412	0.132	0.200	0.096	0.117	0.056	0.067	0.140	0.038	0.264	0.113	0.084	0.362	3
14	9/16	9/16	0.427	0.462	0.148	0.224	0.108	0.132	0.064	0.075	0.152	0.039	0.282	0.125	0.093	0.410	3
1/4	5/8	5/8	0.442	0.477	0.153	0.232	0.112	0.136	0.064	0.075	0.160	0.040	0.284	0.129	0.095	0.424	3
5/16	5/8	13/16	0.556	0.597	0.191	0.290	0.141	0.171	0.072	0.084	0.226	0.065	0.384	0.155	0.117	0.539	4
3/8	5/8	N/A	0.670	0.717	0.230	0.347	0.170	0.206	0.081	0.094	0.245	0.068	0.404	0.182	0.139	0.653	4
7/16	3/4	N/A	0.715	0.760	0.223	0.345	0.174	0.210	0.081	0.094	0.257	0.070	0.416	0.195	0.150	0.690	4
1/2	3/4	N/A	0.765	0.815	0.223	0.354	0.176	0.216	0.091	0.106	0.271	0.071	0.430	0.212	0.163	0.739	4

FOR MORE DETAILED INFORMATION, PLEASE REFER TO COMPLETE ASME STANDARD, WHICH IS THE GOVERNING STANDARD

ASME B18.6.3 (2013) LFG 10/01/2016

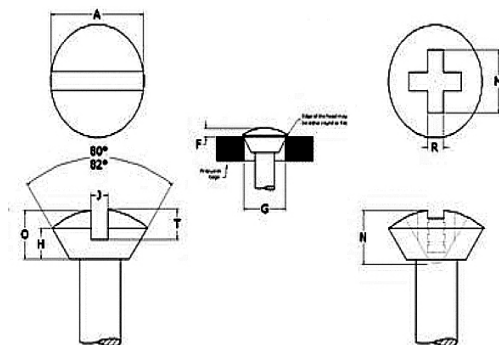

Size	These Lengths and Shorter are Undercut		Dimensions of Head					Dimensions of Slot				Dimensions of Recess			Protrusion Above Gaging		Gaging Diameter	Phillips Drive Bit Size
			Diameter		Side	Total Height		Depth		Width		Depth	Width	Diameter	Min.	Ma.		
	Other Types	Type A & AB	Min.	Max.	Ref.	Min.	Max.	Min.	Max.	Min.	Max.	Ref.	Ref.	Ref.	Min.	Ma.		
0	1/8	3/16	0.096	0.112	0.025	0.033	0.046	0.022	0.028	0.016	0.023	0.036	0.014	0.068	0.031	0.047	0.078	0
1	5/32	3/16	0.120	0.137	0.031	0.042	0.056	0.027	0.034	0.019	0.026	0.039	0.015	0.070	0.035	0.053	0.101	0
2	3/16	3/16	0.144	0.162	0.036	0.050	0.065	0.033	0.040	0.023	0.031	0.060	0.018	0.106	0.039	0.058	0.124	1
3	7/32	7/32	0.167	0.187	0.042	0.059	0.075	0.038	0.047	0.027	0.035	0.072	0.019	0.118	0.044	0.064	0.148	1
4	1/4	1/4	0.910	0.212	0.047	0.067	0.084	0.043	0.053	0.031	0.039	0.086	0.019	0.130	0.048	0.069	0.172	1
5	1/4	1/4	0.215	0.237	0.053	0.076	0.094	0.048	0.059	0.035	0.043	0.073	0.028	0.152	0.053	0.075	0.196	2
6	5/16	5/16	0.238	0.262	0.059	0.084	0.104	0.053	0.065	0.039	0.048	0.092	0.030	0.172	0.057	0.080	0.220	2
7	3/8	3/8	0.262	0.287	0.064	0.093	0.113	0.059	0.071	0.039	0.048	0.098	0.030	0.176	0.062	0.085	0.243	2
8	7/16	7/16	0.285	0.312	0.070	0.101	0.123	0.064	0.078	0.045	0.054	0.107	0.031	0.186	0.066	0.091	0.267	2
10	1/2	1/2	0.333	0.362	0.081	0.118	0.142	0.074	0.090	0.050	0.060	0.125	0.033	0.202	0.075	0.102	0.313	2
12	9/16	9/16	0.380	0.412	0.092	0.135	0.161	0.085	0.103	0.056	0.067	0.140	0.038	0.264	0.084	0.113	0.362	3
1/4	5/8	5/8	0.442	0.477	0.107	0.158	0.186	0.098	0.119	0.064	0.075	0.160	0.040	0.284	0.095	0.129	0.424	3
5/16	5/8	13/16	0.556	0.597	0.134	0.198	0.232	0.124	0.149	0.072	0.084	0.214	0.065	0.374	0.117	0.155	0.539	4
3/8	5/8	N/A	0.670	0.717	0.161	0.239	0.278	0.149	0.179	0.081	0.094	0.233	0.068	0.394	0.139	0.182	0.653	4
7/16	3/4	N/A	0.715	0.760	0.156	0.239	0.279	0.154	0.184	0.081	0.094	0.245	0.070	0.404	0.150	0.195	0.690	4
1/2	3/4	N/A	0.765	0.815	0.156	0.244	0.288	0.169	0.204	0.091	0.106	0.257	0.071	0.416	0.163	0.212	0.739	4

16.10 - INCH OVAL HEAD SCREWS

FOR MORE DETAILED INFORMATION, PLEASE REFER TO COMPLETE ASME STANDARD, WHICH IS THE GOVERNING STANDARD

ASME B18.6.3 (2013) LFG 10/01/2016

CONVERSION DATA

MILLIMETER TO DECIMAL EQUIVALENTS

METRIC	EQUIV. DECIMAL/INCH	METRIC	EQUIV. DECIMAL/INCH	METRIC	EQUIV. DECIMAL/INCH
M1	0.0394	M14	0.5512	M100	3.9370
M1.2	0.0472	M16	0.6299	M120	4.7244
M1.4	0.0551	M18	0.7087	M140	5.5118
M1.6	0.0630	M20	0.7874	M160	6.2992
M1.7	0.0669	M22	0.8661	M180	7.0866
M1.8	0.0709	M24	0.9449	M200	7.8740
M2	0.0787	M27	1.0630	M220	8.6614
M2.2	0.0866	M30	1.1811	M240	9.4488
M2.3	0.0906	M33	1.2992	M260	10.2362
M2.5	0.0984	M36	1.4173	M280	11.0236
M2.6	0.1024	M39	1.5354	M300	11.8110
M3	0.1181	M42	1.6535	M320	12.5984
M3.5	0.1378	M45	1.7717	M340	13.3858
M4	0.1575	M48	1.8898	M360	14.1732
M5	0.1969	M52	2.0472	M380	14.9606
M6	0.2362	M56	2.2047	M400	15.7480
M7	0.2756	M60	2.3622	M420	16.5354
M8	0.3150	M64	2.5197	M440	17.3228
M9	0.3543	M68	2.6772	M460	18.1102
M10	0.3937	M72	2.8346	M480	18.8976
M11	0.4331	M80	3.1496	M500	19.6850
M12	0.4724	M90	3.5433		

FORMULAS: METRIC x 0.03937 = INCH INCH x 25.4 = METRIC

NOMINAL DIAMETER	MM	M2.6	M3	M3.5	M4	M5	M6	M8	M10	M12	M14	M16	M18	M20	M22	M24	M27	M30	M33	M36
INCH		0.102	0.118	0.138	0.157	0.197	0.236	0.315	0.394	0.472	0.551	0.630	0.709	0.787	0.866	0.945	1.0643	1.181	1.299	1.417
PITCH	MM	0.45	0.5	0.6	0.7	0.8	1.0	1.25	1.5	1.75	2	2	2.5	2.5	2.5	3	3	3.5	3.5	4

ANY QUANTITY. ANY SIZE. ANY FINISH.



MANUFACTURED & ALTERED PARTS
CUSTOM FABRICATING
INCH & METRIC SIZES
LARGE & SMALL DIAMETER
LONG LENGTHS
FAST-TRACKED TURNAROUND



SPECIALTY FASTENERS
STEEL, STAINLESS & BRASS
INCH & METRIC SIZES
SECONDARY PROCESSES
MANAGED PROGRAMS
TECHNICAL SERVICES



SMALL PACK FASTENERS
CLASS C COMPONENTS
INCH & METRIC SIZES
CUSTOM PACKAGING
KITS AND ASSORTMENTS
CUSTOM LABELING



BUILDING MEANINGFUL RELATIONSHIPS WITH INTEGRITY, INGENUITY AND ACCOMMODATION



Get quote >>

Angic Global Solutions

<https://www.AngicGlobal.com> Sales@AngicGlobal.com

1-888-872-0690

Angic Global Solutions, All Rights Reserved



Metric and Inch products plated
and packaged per specification



Big ideas in small packed
fasteners and Class C items



Metric and Inch fastener
fabrication for special parts

Minnesota
1-800-328-2430

South Carolina
1-800-572-5550

New York
1-800-838-1565

Illinois
1-800-837-5858

sales@lindfastgrp.com

www.lindstomfasteners.com

