

"The Good Guys"

Fascomp
electronic hardware

DESIGN CATALOG



FINE QUALITY ELECTRONIC HARDWARE



Get quote >>

Angic Global Solutions

1-888-872-0690

<https://www.AngicGlobal.com> Sales@AngicGlobal.com



Orlando, Florida
Corporate



Naugatuck, Connecticut



Shenzhen, China



Jason Bertone - Mark Georgia

"The Good Guys"

We will listen to our customers, analyze the marketplace and work to improve every aspect of our business. We will embrace changes that will benefit our customers, our employees and ourselves. Fascomp will operate in a conscientious and ethical manner and contribute to the charitable interests of our communities.



Versatile and Innovative
Manufacturing



Huge Inventory



A Friendly, knowledgeable staff offers world class service!



Get quote 

Angic Global Solutions

1-888-872-0690

<https://www.AngicGlobal.com> Sales@AngicGlobal.com



Index

Description	Page No.
Depth of Thread - Female Standoffs	1
Minimum Thread Depth - Male-Female Standoffs	2
Material Specifications	3
Compatible Finish Codes	3
Standoff Tolerances	3
Terms of Sales	4
Captive Screws	5
Retainers	54
Spacers	62
Swage Spacers	80
Female Standoffs	85
Square Female Standoffs	100
Swage Standoffs	108
Male-Female Standoffs	121
Male-Male Standoffs	132
Hex Jackscrews	134
Shoulder Screws	141
Thumb Screws	144
Chassis Fasteners	150
Handles	153



Get quote »

Angic Global Solutions

1-888-872-0690

<https://www.AngicGlobal.com> Sales@AngicGlobal.com



Index

Description	Page No.
Metric Spacer	176
Metric Female Standoffs	184
Metric Male-Female Standoffs	195



Get quote »

Angic Global Solutions

1-888-872-0690

<https://www.AngicGlobal.com> Sales@AngicGlobal.com



Depth of Thread - Female Standoffs

American Standard (ASE)

Thread	Tapped Thru		Longer Parts
	Aluminum, Brass & Steel	Stainless Steel	Blind Tap Depth
0-80	3/8	1/4	3/16
1-72	3/8	1/4	3/16
2-56	3/4	5/8	3/16
3-48	3/4	5/8	3/16
3-56	3/4	5/8	3/16
4-40	1	3/4	1/4
4-48	1	3/4	1/4
5-40	1	3/4	5/16
6-32	1	1	3/8
6-40	1	1	3/8
8-32	1	1	7/16
10-24	1-1/8	1	1/2
10-32	1-1/8	1	1/2
12-24	1-1/8	1	1/2
1/4-20	1-1/4	1-1/4	5/8
1/4-28	1-1/4	1-1/4	5/8
5/16-18	1-1/4	1-1/4	5/8
5/16-24	1-1/4	1-1/4	5/8
3/8-16	1-1/4	1-1/4	5/8
3/8-24	1-1/4	1-1/4	5/8
7/16-14	1-1/4	1-1/4	5/8
7-16/20	1-1/4	1-1/4	5/8
1/2-13	1-1/4	1-1/4	5/8
1/2-20	1-1/4	1-1/4	5/8

Metric Thread	Tapped Thru		Longer Parts
	Aluminum, Brass & Steel	Stainless Steel	Blind Tap Depth
M2x0.45	19	16	4.7
M3x0.5	25	19	6.3
M3.5x0.6	25	25	9.5
M4x0.7	25	25	11.1
M5x0.8	28	25	12.7
M6x1	21	31	16
M8x1.25	31	31	16



Get quote >>

Angic Global Solutions

1-888-872-0690

<https://www.AngicGlobal.com> Sales@AngicGlobal.com



Minimum Thread Depth - Male-Female Standoffs

American Standard (ASE) Sizes

Body Length	3/16	1/4	5/16	3/8	7/16	1/2	9/16	5/8
Thread	Minimum Depth							
2-56	.077	.140						
4-40	.070	.133	.195					
6-32		.105	.166	.229	.291			
8-32		.090	.152	.215	.277	.340	.402	
10-32		.078	.140	.203	.265	.328	.434	.452
25-20		.070	.135	.195	.255	.320	.420	.437

Metric Sizes

Body Length	5mm	6mm	7mm	8mm	9mm	10mm	11mm	12mm
Thread	Minimum Depth							
M2.5x0.45	1.9	2.9	3.9					
M3x0.5	1.8	2.8	3.8	4.8	5.8			
M3.5x0.6	1.5	2.5	3.5	4.5	5.5	6.5	7.5	8.5
M4x0.7	1.1	2.1	3.1	4.1	5.1	6.1	7.1	8.1
M5x0.8	.6	1.6	2.6	3.6	4.6	5.6	6.6	7.6

Brass and Steel parts are manufactured to a "pre-plate condition".
Therefore, if they are not subsequently plated, they may accept not-go gauge.

Please call sales office for sizes not listed.



Material Specifications		
Material	Ordering Code	Material Specifications
Aluminum	A	(QQ-A225/3 - QQ-A225/8 - QQ-A200/9)
Aluminum	A	(QQ-A225/8 - QQ-A200/9 - QQ-A2225/8B)
Brass	B	(ASTM-B-16)
Steel	S	QQ-S-637-ASTM-108)
Stainless Steel	SS	ASTM-A-581, A-582 (Non-Magnetic)
Nylon	N	LP-410A

Compatible Finish Codes		
Ordering Code	Material	Finish
0	A, B, S, SS	Plain
5	B, S	Nickel Plate (QQ-N-290)
6	A	Iridite #14 Gold (MIL-C-5541E)
7	A	Iridite Clear (MIL-C-5541E)
9	A	Alodine 1200
12	B, S	Zinc Clear (ASTM-B-633)
16	B, S	Electro Tin (MIL-T-10727 TYPE 1)
20	SS	Passivation (MIL-F-14072D)
22	A	Clear Anodize (MIL-A-8625-TYPE2) (Sulphuric) Hot Water Seal (Clear)
24	A	Black Anodize (MIL-A-8625)
26	B, S, SS	Black Oxide
28	B, S	Zinc Yellow (ASTM-B-633)

Standoff Tolerances

ALUMINUM, BRASS, STEEL & STAINLESS STEEL

- Lengths up to and including 6" (inches) the tolerance is +/- .005
- Lengths over 6" (inches) the tolerance is +/- .010
- Lengths up to and including 99 mm (millimeters) the tolerance is +/- .13 mm
- Lengths from 100 mm to 150 mm the tolerance is +/- .20 mm
- Lengths over 150 mm the tolerance is +/- .25 mm

Tolerances for the outside diameters are +/- .005.

NYLON

- For all lengths the tolerance is +/- .010
- For the outside diameter the tolerance is +/- .010



Get quote »

Angic Global Solutions

1-888-872-0690

<https://www.AngicGlobal.com> Sales@AngicGlobal.com



Terms of Sale

- **F.O.B.** Orlando, Florida.
- **Payment terms:** 1 Percent 10 days net 30 days (upon approval).
- **Quotations:** Prices quoted are valid for 60 days. Clerical and or typographical errors are subject to correction.
- **Shipments:** Fascomp welcomes blanket orders and will accept schedules up to a 12 month period at no additional charge. Fascomp also will drop ship direct to your customer, using your paperwork, at no additional charge. Standard items will be shipped to the quantity ordered. Custom (non-catalog) items may be over-shipped by up to 10 percent.
- **Returns:** No returns will be accepted without prior authorization from Fascomp. Return authorization must be in writing and from an authorized Fascomp representative.
- **Cancellations:** Cancellation approval must come in writing from our sales office. Buyer assumes liability and makes payment to the seller for all work, whether in process or complete at the time of the request to cancel.
- **Inspection:** All parts are manufactured to specifications in effect at the time of the sale. When inspecting, the main criteria should be product function ability. Fascomp reserves the right to change specifications provided the function ability of the item is not altered.
- **Warranty:** All Fascomp products are warranted to the original purchaser. Products are to be free from defects in material or workmanship. Fascomp does not warrant the performance of its products for any particular purpose. Products found to be defective in the judgment of an authorized Fascomp representative will be replaced at no charge to the buyer. Fascomp's responsibility ends 10 days after customer has received parts.
Purchaser's sole remedy with respect to any defective product sold by Fascomp is limited exclusively to the replacement of such defective product. The warranty is voided if repairs are attempted by anyone other than Fascomp without written authorization from a Fascomp Representative.
- **Force Majeure:** Fascomp shall not be liable for failure to perform any of its obligations under this agreement when such failure is caused by the occurrence of any contingency beyond the reasonable control of such party including but not limited to unexpected difficulties when setting up or producing parts, fire, flood, strikes, war, accidents, insurrection, acts of God such as hurricanes, tornados, etc., orders of Governmental agencies or failure or delay of transportation. Fascomp's maximum liability shall be limited to the cost of the parts. The rights and obligations of all parties will be governed by and construed in accordance with the laws in the state of Florida. All disputes will be adjudicated in the state of Florida. In the event the buyer fails to comply with the terms and conditions of sale, buyer shall be liable for without limitation, all losses, costs and expenses that are a result of such default. If such contingency does occur, Fascomp may allocate deliveries amongst its customers as Fascomp see fit. A purchase order shall deem acceptance of these terms

These terms supersede all other contracts or verbal representations, without exception.



Fascomp Electronic Hardware
7814 Kingspointe Pkwy
Orlando, FL 32819
fascomp.com
07) 226-2112





Captive Screws



Fascomp stocks type 1, type 2, type 3, type 4, type 5, and type 6 Captive Screws in aluminum, brass, steel, and stainless steel.

Fascomp also stocks type 5 Washers in aluminum, brass, steel, and stainless steel.

	Page No.
Type 1	6
Type 2	17
Type 3	28
Type 4	39
Type 5	47
Type 5 Washers	53
Type 6	136



Fascomp Electronic Hardware
7814 Kingspointe Pkwy
Orlando, FL 32819
www.fascomp.com
Tel: (407) 226-2112



Get quote >>

Angic Global Solutions

1-888-872-0690

<https://www.AngicGlobal.com> Sales@AngicGlobal.com



Captive Screws Type 1



Fascomp stocks type 1 Captive Screws in aluminum, brass, steel, and stainless steel.

	Page No.
4-40 Thread	7
6-32 Thread	8
8-32 Thread	9
10-24 Thread	10
10-32 Thread	11
12-24 Thread	12
1/4-20 Thread	13
1/4-28 Thread	14
5/16-18 Thread	15
5/16-24 Thread	16



Fascomp Electronic Hardware
7814 Kingspointe Pkwy
Orlando, FL 32819
www.fascomp.com
(407) 226-2112



Get quote »

Captive Screw Type 1 4-40 Thread

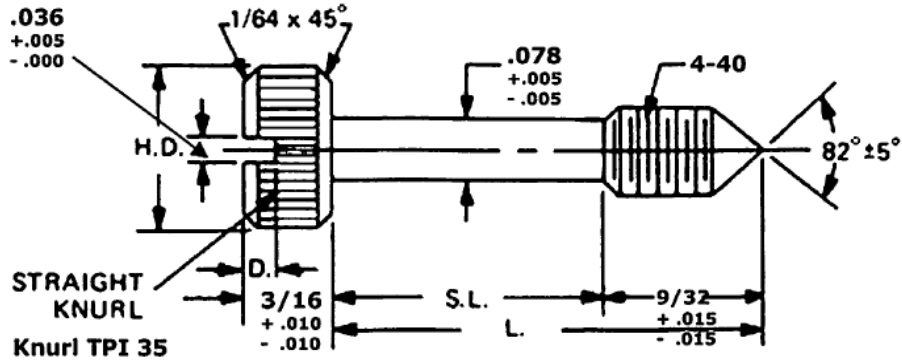

- Contact Sales Office for sizes not shown
- Source Control Drawing: To be produced by Fascomp Electronic Hardware

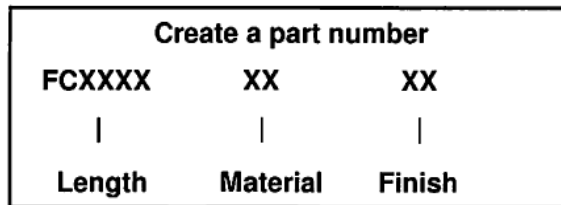

FCXXX	Length (L)	H.D. +.015 -.000	S.L. +.010 -.010	D. +.010 -.000
FC0100	21/32	5/16	3/8	1/16
FC0101	23/32	5/16	7/16	1/16
FC0102	25/32	5/16	1/2	1/16
FC0103	27/32	5/16	9/16	1/16
FC0104	29/32	5/16	5/8	1/16

Material	
Material Code (XX)	
B	Brass
S	Steel
SS	Stainless Steel

See page 3 for finish codes



Fascomp Electronic Hardware
 7814 Kingspointe Pkwy
 Orlando, FL 32819
 www.fascomp.com
 Tel: (407) 226-2112
 Fax: (407) 226-3333



Get quote >>

Angic Global Solutions

1-888-872-0690

<https://www.AngicGlobal.com> Sales@AngicGlobal.com

Captive Screw Type 1 6-32 Thread

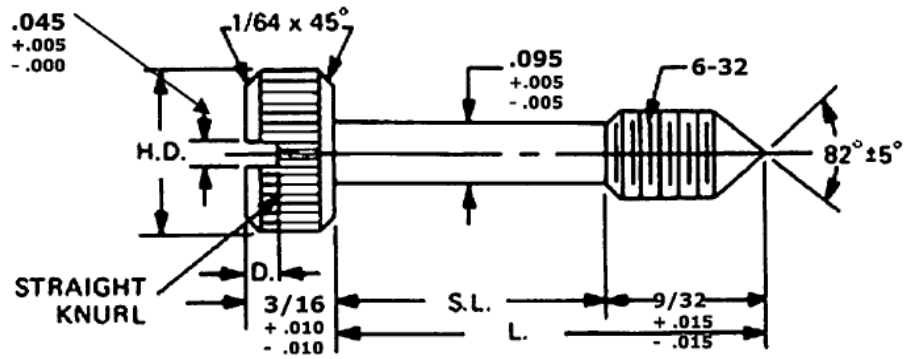

- Contact Sales Office for sizes not shown
- Source Control Drawing: To be produced by Fascomp Electronic Hardware

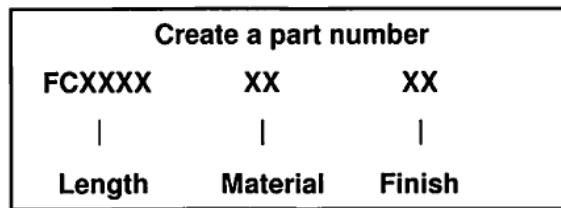

FCXXXX	Length (L)	H.D. +.015 -.000	S.L. +.010 -.010	D. +.010 -.000	Knurl TPI
FC0105	21/32	5/16	3/8	1/16	35
FC0106	23/32	5/16	7/16	1/16	35
FC0107	25/32	5/16	1/2	1/16	35
FC0108	27/32	5/16	9/16	1/16	35
FC0109	29/32	5/16	5/8	1/16	35
FC0110	21/32	3/8	3/8	1/16	30
FC0111	23/32	3/8	7/16	1/16	30
FC0112	25/32	3/8	1/2	1/16	30
FC0113	27/32	3/8	9/16	1/16	30
FC0114	29/32	3/8	5/8	1/16	30

Material	
Material Code (XX)	
B	Brass
S	Steel
SS	Stainless Steel

See page 3 for finish codes



Fascomp Electronic Hardware
7814 Kingspointe Pkwy
Orlando, FL 32819
www.fascomp.com
Tel: (407) 226-2112
(407) 226-3370



Get quote >>

Captive Screw Type 1 8-32 Thread

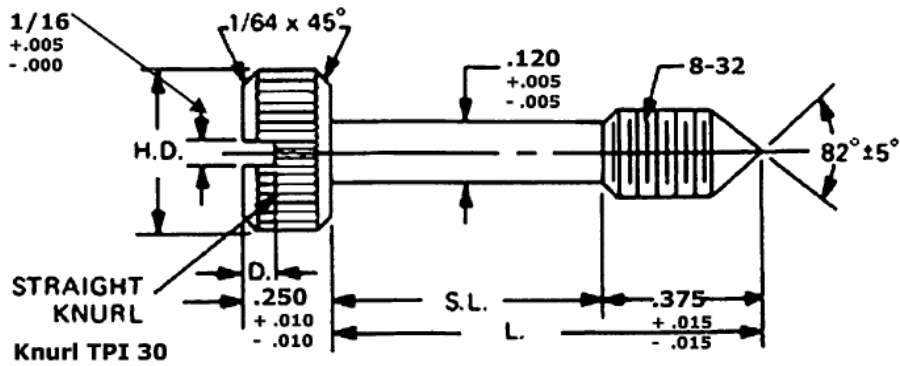

- Contact Sales Office for sizes not shown
- Source Control Drawing: To be produced by Fascomp Electronic Hardware

FCXXX	Length (L)	H.D. +.015 -.000	S.L. +.010 -.010	D. +.010 -.000
FC0115	5/8	7/16	1/4	1/16
FC0116	11/16	7/16	5/16	1/16
FC0117	3/4	7/16	3/8	1/16
FC0118	13/16	7/16	7/16	1/16
FC0119	7/8	7/16	1/2	1/16
FC0120	15/16	7/16	9/16	1/16
FC0121	1	7/16	5/8	1/16
FC0122	1-1/16	7/16	11/16	1/16
FC0123	1-1/8	7/16	3/4	1/16
FC0124	1-3/16	7/16	13/16	1/16
FC0125	1-1/4	7/16	7/8	1/16
FC0126	1-5/16	7/16	15/16	1/16
FC0127	1-3/8	7/16	1	1/16
FC0128	1-7/16	7/16	1-1/16	1/16
FC0129	1-1/2	7/16	1-1/8	1/16
FC0130	1-9/16	7/16	1-3/16	1/16
FC0131	1-5/8	7/16	1-1/4	1/16
FC0132	1-11/16	7/16	1-5/16	1/16
FC0133	1-3/4	7/16	1-3/8	1/16
FC0134	1-13/16	7/16	1-7/16	1/16
FC0135	1-7/8	7/16	1-1/2	1/16
FC0136	1-15/16	7/16	1-9/16	1/16
FC0137	2	7/16	1-5/8	1/16

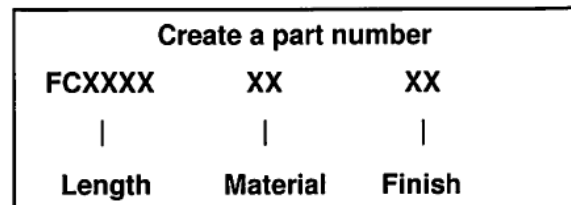

Material	
Material Code (XX)	
B	Brass
S	Steel
SS	Stainless Steel

See page 3 for finish codes



Fascomp Electronic Hardware
 7814 Kingspointe Pkwy
 Orlando, FL 32819
 www.fascomp.com
 Tel: (407) 226-2112



Get quote >>

Captive Screw Type 1 10-24 Thread

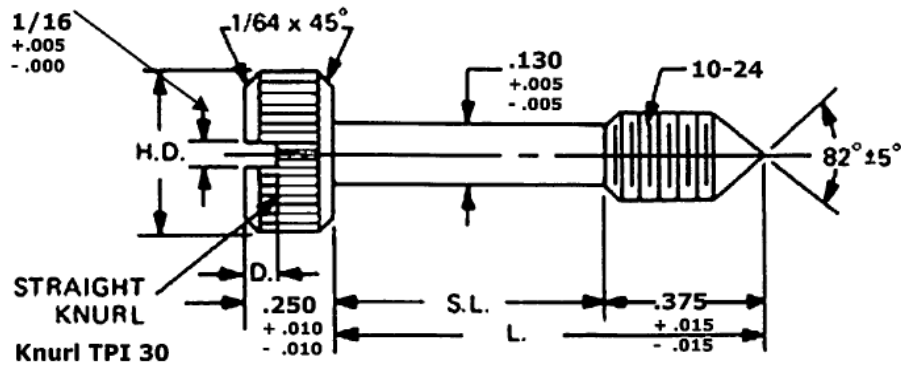

- Contact Sales Office for sizes not shown
- Source Control Drawing: To be produced by Fascomp Electronic Hardware

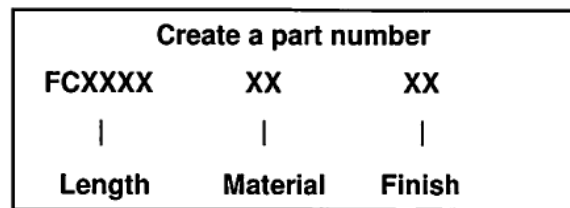

FCXXX	Length (L)	H.D. +.015 -.000	S.L. +.010 -.010	D. +.010 -.000
FC0138	5/8	7/16	1/4	1/16
FC0139	11/16	7/16	5/16	1/16
FC0140	3/4	7/16	3/8	1/16
FC0141	13/16	7/16	7/16	1/16
FC0142	7/8	7/16	1/2	1/16
FC0143	15/16	7/16	9/16	1/16
FC0144	1	7/16	5/8	1/16
FC0145	1-1/16	7/16	11/16	1/16
FC0146	1-1/8	7/16	3/4	1/16
FC0147	1-3/16	7/16	13/16	1/16
FC0148	1-1/4	7/16	7/8	1/16
FC0149	1-5/16	7/16	15/16	1/16
FC0150	1-3/8	7/16	1	1/16
FC0151	1-7/16	7/16	1-1/16	1/16
FC0152	1-1/2	7/16	1-1/8	1/16
FC0153	1-9/16	7/16	1-3/16	1/16
FC0154	1-5/8	7/16	1-1/4	1/16
FC0155	1-11/16	7/16	1-5/16	1/16
FC0156	1-3/4	7/16	1-3/8	1/16
FC0157	1-13/16	7/16	1-7/16	1/16
FC0158	1-7/8	7/16	1-1/2	1/16
FC0159	1-15/16	7/16	1-9/16	1/16
FC0160	2	7/16	1-5/8	1/16

Material	
Material Code (XX)	
B	Brass
S	Steel
SS	Stainless Steel

See page 3 for finish codes



Fascomp Electronic Hardware
7814 Kingspointe Pkwy
Orlando, FL 32819
www.fascomp.com
Tel: (407) 226-2112



Captive Screw Type 1 10-32 Thread

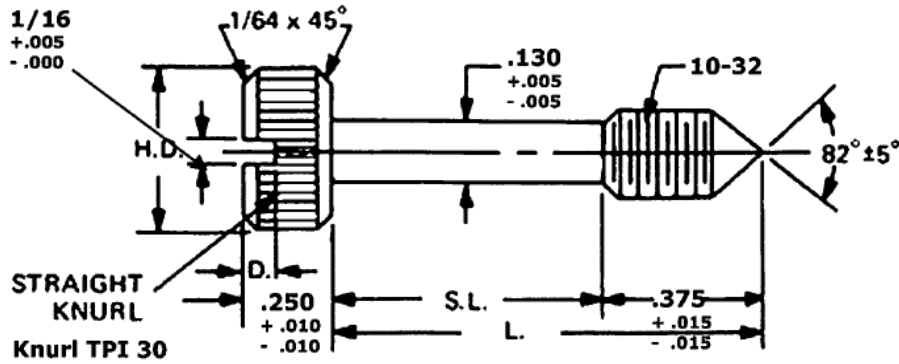

- Contact Sales Office for sizes not shown
- Source Control Drawing: To be produced by Fascomp Electronic Hardware

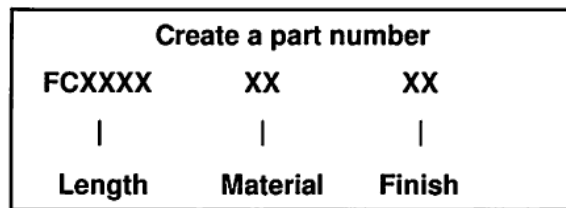

FCXXXX	Length (L)	H.D.	S.L.	D.
		+015 -000	+010 -010	+010 -000
FC0161	5/8	7/16	1/4	1/16
FC0162	11/16	7/16	5/16	1/16
FC0163	3/4	7/16	3/8	1/16
FC0164	13/16	7/16	7/16	1/16
FC0165	7/8	7/16	1/2	1/16
FC0166	15/16	7/16	9/16	1/16
FC0167	1	7/16	5/8	1/16
FC0168	1-1/16	7/16	11/16	1/16
FC0169	1-1/8	7/16	3/4	1/16
FC0170	1-3/16	7/16	13/16	1/16
FC0171	1-1/4	7/16	7/8	1/16
FC0172	1-5/16	7/16	15/16	1/16
FC0173	1-3/8	7/16	1	1/16
FC0174	1-7/16	7/16	1-1/16	1/16
FC0175	1-1/2	7/16	1-1/8	1/16
FC0176	1-9/16	7/16	1-3/16	1/16
FC0177	1-5/8	7/16	1-1/4	1/16
FC0178	1-11/16	7/16	1-5/16	1/16
FC0179	1-3/4	7/16	1-3/8	1/16
FC0180	1-13/16	7/16	1-7/16	1/16
FC0181	1-7/8	7/16	1-1/2	1/16
FC0182	1-15/16	7/16	1-9/16	1/16
FC0183	2	7/16	1-5/8	1/16

Material	
Material Code (XX)	
B	Brass
S	Steel
SS	Stainless Steel

See page 3 for finish codes



Fascomp Electronic Hardware
7814 Kingspointe Pkwy
Orlando, FL 32819
www.fascomp.com

Fa Angic Global Solutions

1-888-872-0690

<https://www.AngicGlobal.com> Sales@AngicGlobal.com



Get quote >>

Captive Screw Type 1 12-24 Thread

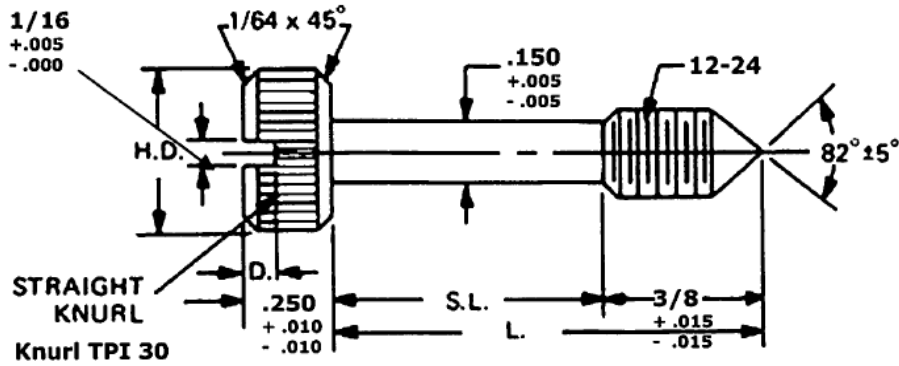

- Contact Sales Office for sizes not shown
- Source Control Drawing: To be produced by Fascomp Electronic Hardware

FCXXX	Length (L)	H.D. +.015 -.000	S.L. +.010 -.010	D. +.010 -.000
FC0184	5/8	9/16	1/4	3/32
FC0185	11/16	9/16	5/16	3/32
FC0186	3/4	9/16	3/8	3/32
FC0187	13/16	9/16	7/16	3/32
FC0188	7/8	9/16	1/2	3/32
FC0189	15/16	9/16	9/16	3/32
FC0190	1	9/16	5/8	3/32
FC0191	1-1/16	9/16	11/16	3/32
FC0192	1-1/8	9/16	3/4	3/32
FC0193	1-3/16	9/16	13/16	3/32
FC0194	1-1/4	9/16	7/8	3/32
FC0195	1-5/16	9/16	15/16	3/32
FC0196	1-3/8	9/16	1	3/32
FC0197	1-7/16	9/16	1-1/16	3/32
FC0198	1-1/2	9/16	1-1/8	3/32
FC0199	1-9/16	9/16	1-3/16	3/32
FC0200	1-5/8	9/16	1-1/4	3/32
FC0201	1-11/16	9/16	1-5/16	3/32
FC0202	1-3/4	9/16	1-3/8	3/32
FC0203	1-13/16	9/16	1-7/16	3/32
FC0204	1-7/8	9/16	1-1/2	3/32
FC0205	1-15/16	9/16	1-9/16	3/32
FC0206	2	9/16	1-5/8	3/32

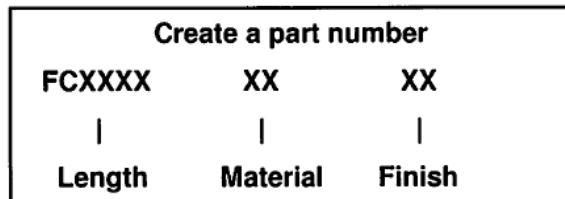

Material	
Material Code (XX)	
B	Brass
S	Steel
SS	Stainless Steel

See page 3 for finish codes



Fascomp Electronic Hardware
7814 Kingspointe Pkwy
Orlando, FL 32819
www.fascomp.com

F. Angic Global Solutions

1-888-872-0690

<https://www.AngicGlobal.com> Sales@AngicGlobal.com



Get quote >>

Captive Screw Type 1 1/4-20 Thread

FCXXX	Length (L)	H.D. +.015 -.000	S.L. +.010 -.010	D. +.010 -.000
FC0207	5/8	9/16	1/4	3/32
FC0208	11/16	9/16	5/16	3/32
FC0209	3/4	9/16	3/8	3/32
FC0210	13/16	9/16	7/16	3/32
FC2011	7/8	9/16	1/2	3/32
FC2012	15/16	9/16	9/16	3/32
FC2013	1	9/16	5/8	3/32
FC2014	1-1/16	9/16	11/16	3/32
FC2015	1-1/8	9/16	3/4	3/32
FC2016	1-3/16	9/16	13/16	3/32
FC0217	1-1/4	9/16	7/8	3/32
FC0218	1-5/16	9/16	15/16	3/32
FC2019	1-3/8	9/16	1	3/32
FC0220	1-7/16	9/16	1-1/16	3/32
FC0221	1-1/2	9/16	1-1/8	3/32
FC0222	1-9/16	9/16	1-3/16	3/32
FC0223	1-5/8	9/16	1-1/4	3/32
FC0224	1-11/16	9/16	1-5/16	3/32
FC0225	1-3/4	9/16	1-3/8	3/32
FC0226	1-13/16	9/16	1-7/16	3/32
FC0227	1-7/8	9/16	1-1/2	3/32
FC0228	1-15/16	9/16	1-9/16	3/32
FC0229	2	9/16	1-5/8	3/32
FC0230	5/8	3/4	1/4	1/8
FC0231	11/16	3/4	5/16	1/8
FC0232	3/4	3/4	3/8	1/8
FC0233	13/16	3/4	7/16	1/8
FC0234	7/8	3/4	1/2	1/8
FC0235	15/16	3/4	9/16	1/8
FC0236	1	3/4	5/8	1/8
FC0237	1-1/16	3/4	11/16	1/8
FC0238	1-1/8	3/4	3/4	1/8
FC0239	1-3/16	3/4	13/16	1/8
FC0240	1-1/4	3/4	7/8	1/8
FC0241	1-5/16	3/4	15/16	1/8
FC0242	1-3/8	3/4	1	1/8
FC0243	1-7/16	3/4	1-1/16	1/8
FC0244	1-1/2	3/4	1-1/8	1/8
FC0245	1-9/16	3/4	1-3/16	1/8
FC0246	1-5/8	3/4	1-1/4	1/8
FC0247	1-11/16	3/4	1-5/16	1/8
FC0248	1-3/4	3/4	1-3/8	1/8
FC0249	1-13/16	3/4	1-7/16	1/8
FC0250	1-7/8	3/4	1-1/2	1/8
FC0251	1-15/16	3/4	1-9/16	1/8
FC0252				

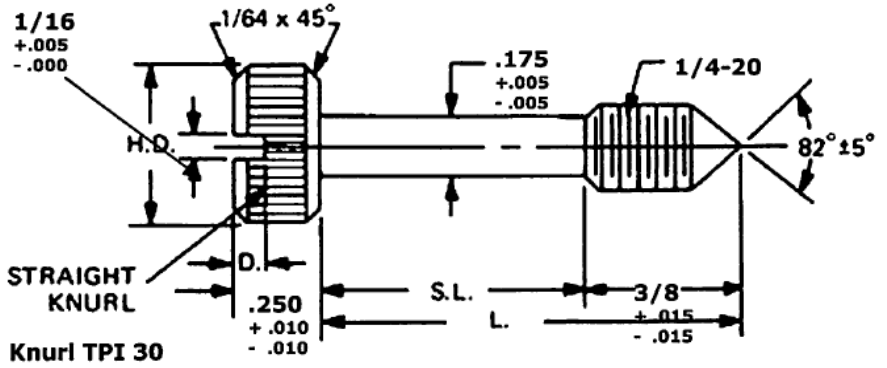

- Contact Sales Office for sizes not shown
- Source Control Drawing: To be produced by Fascomp Electronic Hardware

Create a part number		
FCXXX	XX	XX
Length	Material	Finish

Material	
Material Code (XX)	
B	Brass
S	Steel
SS	Stainless Steel

See page 3 for finish codes



Fascomp Electronic Hardware
7814 Kingspointe Pkwy
Orlando, FL 32819
www.fascomp.com

F Angic Global Solutions

1-888-872-0690 3

<https://www.AngicGlobal.com> Sales@AngicGlobal.com



Get quote >>

Captive Screw Type 1 1/4-28 Thread

FCXXX	Length (L)	H.D. +.015 -.000	S.L. +.010 -.010	D. +.010 -.000
FC0253	5/8	9/16	1/4	3/32
FC0254	11/16	9/16	5/16	3/32
FC0255	3/4	9/16	3/8	3/32
FC0256	13/16	9/16	7/16	3/32
FC0257	7/8	9/16	1/2	3/32
FC0258	15/16	9/16	9/16	3/32
FC0259	1	9/16	5/8	3/32
FC0260	1-1/16	9/16	11/16	3/32
FC0261	1-1/8	9/16	3/4	3/32
FC0262	1-3/16	9/16	13/16	3/32
FC0263	1-1/4	9/16	7/8	3/32
FC0264	1-5/16	9/16	15/16	3/32
FC0265	1-3/8	9/16	1	3/32
FC0266	1-7/16	9/16	1-1/16	3/32
FC0267	1-1/2	9/16	1-1/8	3/32
FC0268	1-9/16	9/16	1-3/16	3/32
FC0269	1-5/8	9/16	1-1/4	3/32
FC0270	1-11/16	9/16	1-5/16	3/32
FC0271	1-3/4	9/16	1-3/8	3/32
FC0272	1-13/16	9/16	1-7/16	3/32
FC0273	1-7/8	9/16	1-1/2	3/32
FC0274	1-15/16	9/16	1-9/16	3/32
FC0275	2	9/16	1-5/8	3/32
FC0276	5/8	3/4	1/4	1/8
FC0277	11/16	3/4	5/16	1/8
FC0278	3/4	3/4	3/8	1/8
FC0279	13/16	3/4	7/16	1/8
FC0280	7/8	3/4	1/2	1/8
FC0281	15/16	3/4	9/16	1/8
FC0282	1	3/4	5/8	1/8
FC0283	1-1/16	3/4	11/16	1/8
FC0284	1-1/8	3/4	3/4	1/8
FC0285	1-3/16	3/4	13/16	1/8
FC0286	1-1/4	3/4	7/8	1/8
FC0287	1-5/16	3/4	15/16	1/8
FC0288	1-3/8	3/4	1	1/8
FC0289	1-7/16	3/4	1-1/16	1/8
FC0290	1-1/2	3/4	1-1/8	1/8
FC0291	1-9/16	3/4	1-3/16	1/8
FC0292	1-5/8	3/4	1-1/4	1/8
FC0293	1-11/16	3/4	1-5/16	1/8
FC0294	1-3/4	3/4	1-3/8	1/8
FC0295	1-13/16	3/4	1-7/16	1/8
FC0296	1-7/8	3/4	1-1/2	1/8
FC0297	1-15/16	3/4	1-9/16	1/8
FC0298	2	3/4	1-5/8	1/8

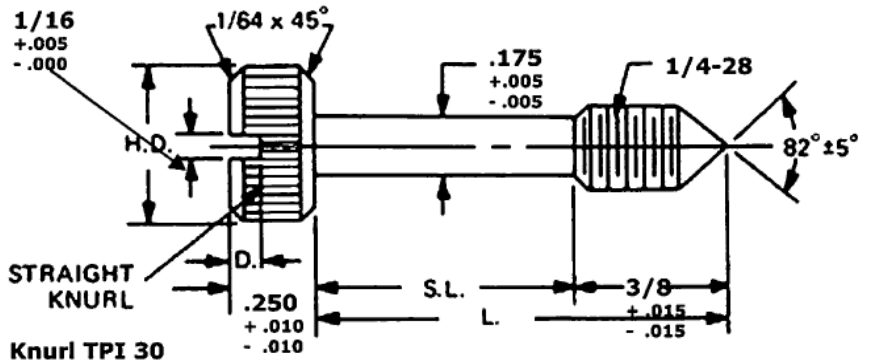

- Contact Sales Office for sizes not shown
- Source Control Drawing: To be produced by Fascomp Electronic Hardware

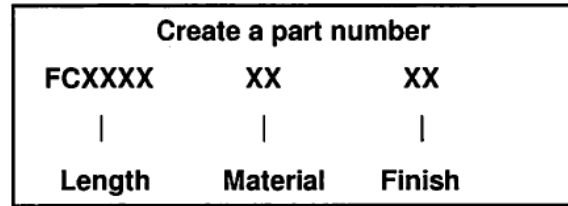

Material	
Material Code (XX)	
B	Brass
S	Steel
SS	Stainless Steel

See page 3 for finish codes



Fascomp Electronic Hardware
7814 Kingspointe Pkwy
Orlando, FL 32819
www.fascomp.com



Captive Screw Type 1 5/16-18 Thread

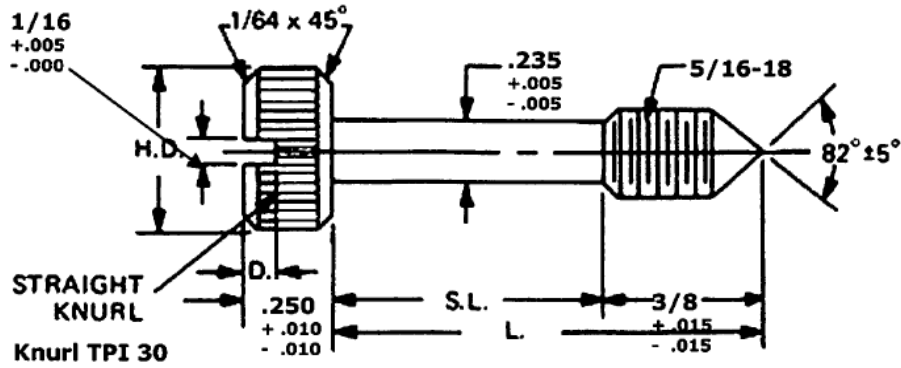

FCXXX	Length (L)	H.D. +.015 -.000	S.L. +.010 -.010	D. +.010 -.000
FC0299	1	9/16	5/8	3/32
FC0300	1-1/16	9/16	11/16	3/32
FC0301	1-1/8	9/16	3/4	3/32
FC0302	1-3/16	9/16	13/16	3/32
FC0303	1-1/4	9/16	7/8	3/32
FC0304	1-5/16	9/16	15/16	3/32
FC0305	1-3/8	9/16	1	3/32
FC0306	1-7/16	9/16	1-1/16	3/32
FC0307	1-1/2	9/16	1-1/8	3/32
FC0308	1-9/16	9/16	1-3/16	3/32
FC0309	1-5/8	9/16	1-1/4	3/32
FC0310	1-11/16	9/16	1-5/16	3/32
FC0311	1-3/4	9/16	1-3/8	3/32
FC0312	1-13/16	9/16	1-7/16	3/32
FC0313	1-7/8	9/16	1-1/2	3/32
FC0314	1-15/16	9/16	1-9/16	3/32
FC0315	2	9/16	1-5/8	3/32
FC0316	1	3/4	5/8	1/8
FC0317	1-1/16	3/4	11/16	1/8
FC0318	1-1/8	3/4	3/4	1/8
FC0319	1-3/16	3/4	13/16	1/8
FC0320	1-1/4	3/4	7/8	1/8
FC0321	1-5/16	3/4	15/16	1/8
FC0322	1-3/8	3/4	1	1/8
FC0323	1-7/16	3/4	1-1/16	1/8
FC0324	1-1/2	3/4	1-1/8	1/8
FC0325	1-9/16	3/4	1-3/16	1/8
FC0326	1-5/8	3/4	1-1/4	1/8
FC0327	1-11/16	3/4	1-5/16	1/8
FC0328	1-3/4	3/4	1-3/8	1/8
FC0329	1-13/16	3/4	1-7/16	1/8
FC0330	1-7/8	3/4	1-1/2	1/8
FC0331	1-15/16	3/4	1-9/16	1/8
FC0332				

- Contact Sales Office for sizes not shown
- Source Control Drawing: To be produced by Fascomp Electronic Hardware

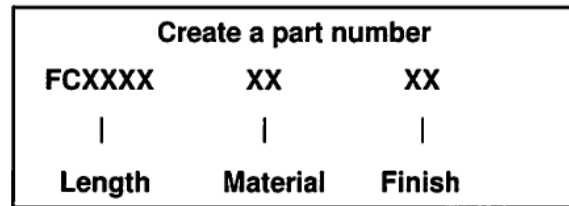

Material	
Material Code (XX)	
B	Brass
S	Steel
SS	Stainless Steel

See page 3 for finish codes



Fascomp Electronic Hardware
7814 Kingspointe Pkwy
Orlando, FL 32819
www.fascomp.com



Get quote >>

Captive Screw Type 1 5/16-24 Thread

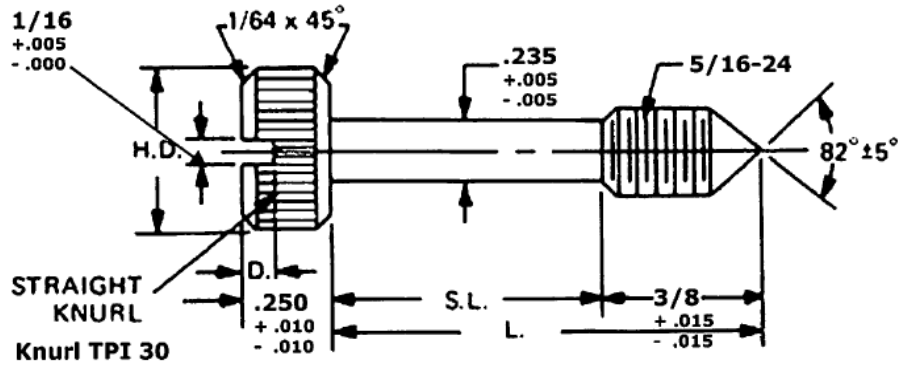

FCXXX	Length (L)	H.D. +.015 -.000	S.L. +.010 -.010	D. +.010 -.000
FC0333	1	9/16	5/8	3/32
FC0334	1-1/16	9/16	11/16	3/32
FC0335	1-1/8	9/16	3/4	3/32
FC0336	1-3/16	9/16	13/16	3/32
FC0337	1-1/4	9/16	7/8	3/32
FC0338	1-5/16	9/16	15/16	3/32
FC0339	1-3/8	9/16	1	3/32
FC0340	1-7/16	9/16	1-1/16	3/32
FC0341	1-1/2	9/16	1-1/8	3/32
FC0342	1-9/16	9/16	1-3/16	3/32
FC0343	1-5/8	9/16	1-1/4	3/32
FC0344	1-11/16	9/16	1-5/16	3/32
FC0345	1-3/4	9/16	1-3/8	3/32
FC0346	1-13/16	9/16	1-7/16	3/32
FC0347	1-7/8	9/16	1-1/2	3/32
FC0348	1-15/16	9/16	1-9/16	3/32
FC0349	2	9/16	1-5/8	3/32
FC0350	1	3/4	5/8	1/8
FC0351	1-1/16	3/4	11/16	1/8
FC0352	1-1/8	3/4	3/4	1/8
FC0353	1-3/16	3/4	13/16	1/8
FC0354	1-1/4	3/4	7/8	1/8
FC0355	1-5/16	3/4	15/16	1/8
FC0356	1-3/8	3/4	1	1/8
FC0357	1-7/16	3/4	1-1/16	1/8
FC0358	1-1/2	3/4	1-1/8	1/8
FC0359	1-9/16	3/4	1-3/16	1/8
FC0360	1-5/8	3/4	1-1/4	1/8
FC0361	1-11/16	3/4	1-5/16	1/8
FC0362	1-3/4	3/4	1-3/8	1/8
FC0363	1-13/16	3/4	1-7/16	1/8
FC0364	1-7/8	3/4	1-1/2	1/8
FC0365	1-15/16	3/4	1-9/16	1/8
FC0366	2	3/4	1-5/8	1/8

- Contact Sales Office for sizes not shown
- Source Control Drawing: To be produced by Fascomp Electronic Hardware

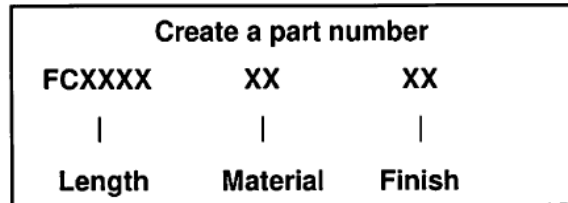

Material	
Material Code (XX)	
B	Brass
S	Steel
SS	Stainless Steel

See page 3 for finish codes



Fascomp Electronic Hardware
7814 Kingspointe Pkwy
Orlando, FL 32819
www.fascomp.com





Captive Screws Type 2



Fascomp stocks type 2 Captive Screws in aluminum, brass, steel, and stainless

	Page No.
4-40 Thread	18
6-32 Thread	19
8-32 Thread	20
10-24 Thread	21
10-32 Thread	22
1/4-20 Thread	23
1/4-28 Thread	24
5/16-18 Thread	25
5/16-24 Thread	26
3/8-16 Thread	27

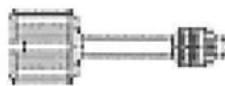

Fascomp Electronic Hardware
7814 Kingspointe Pkwy
Orlando, FL 32819
www.fascomp.com
Tel: (407) 226-2



Get quote >>

Angic Global Solutions

1-888-872-0690 7

<https://www.AngicGlobal.com> Sales@AngicGlobal.com

Captive Screw Type 2 4-40 Thread

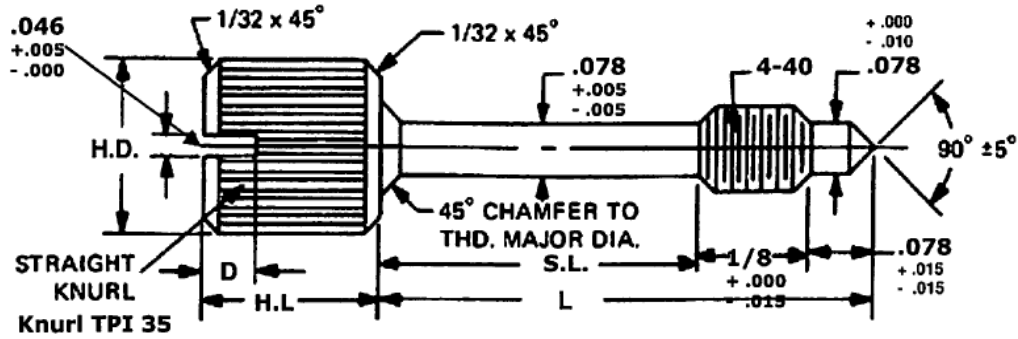

- Contact Sales Office for sizes not shown
- Source Control Drawing: To be produced by Fascomp Electronic Hardware

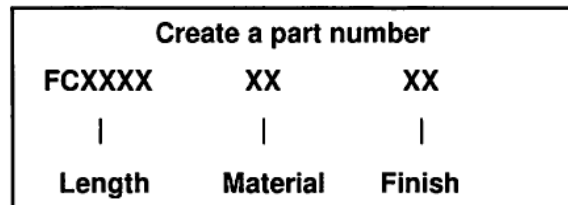

FCXXX	Length (L)	H.D. +.015 -.000	H.L. +.010 -.010	S.L. +.010 -.010	D. +.010 -.000
FC0367	3/8	1/4	1/4	11/64	.078
FC0368	7/16	1/4	1/4	15/64	.078
FC0369	1/2	1/4	1/4	19/64	.078
FC0370	9/16	1/4	1/4	23/64	.078
FC0371	5/8	1/4	1/4	27/64	.078
FC0372	11/16	1/4	1/4	31/64	.078
FC0373	3/4	1/4	1/4	35/64	.078
FC0374	13/16	1/4	1/4	39/64	.078
FC0375	7/8	1/4	1/4	43/64	.078
FC0376	15/16	1/4	1/4	47/64	.078
FC0377	1	1/4	1/4	51/64	.078
FC0378	3/8	5/16	5/16	11/64	.078
FC0379	7/16	5/16	5/16	15/64	.078
FC0380	1/2	5/16	5/16	19/64	.078
FC0381	9/16	5/16	5/16	23/64	.078
FC0382	5/8	5/16	5/16	27/64	.078
FC0383	11/16	5/16	5/16	31/64	.078
FC0384	3/4	5/16	5/16	35/64	.078
FC0385	13/16	5/16	5/16	39/64	.078
FC0386	7/8	5/16	5/16	43/64	.078
FC0387	15/16	5/16	5/16	47/64	.078
FC0388	1	5/16	5/16	51/64	.078

Material	
Material Code (XX)	
B	Brass
S	Steel
SS	Stainless Steel

See page 3 for finish codes



Fascomp Electronic Hardware
7814 Kingspointe Pkwy
Orlando, FL 32819
www.fascomp.com
Tel: (407) 226-2112
Fax: (407) 226-3370



Get quote >>

Captive Screw Type 2 6-32 Thread

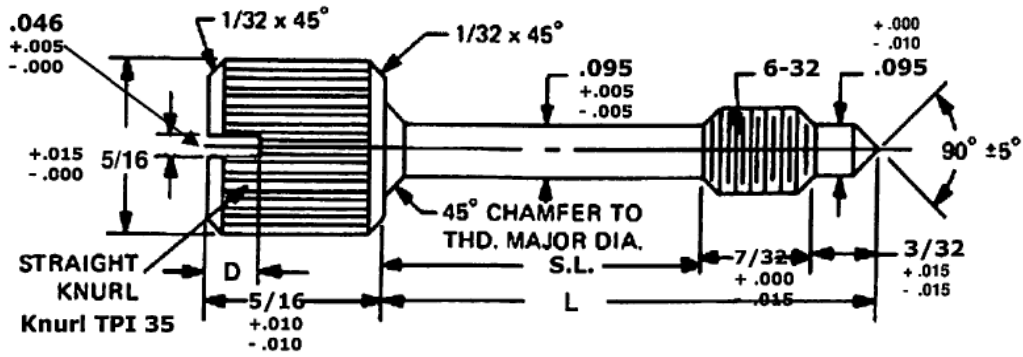

- Contact Sales Office for sizes not shown
- Source Control Drawing: To be produced by Fascomp Electronic Hardware

FCXXXX	Length (L)	S.L. +.010 -.010	D. +.010 -.000
FC0389	7/16	1/8	.078
FC0390	1/2	3/16	.078
FC0391	9/16	1/4	.078
FC0392	5/8	5/16	.078
FC0393	11/16	3/8	.078
FC0394	3/4	7/16	.078
FC0395	13/16	1/2	.078
FC0396	7/8	9/16	.078
FC0397	15/16	5/8	.078
FC0398	1	11/16	.078
FC0399	1-1/16	3/4	.078
FC0400	1-1/8	13/16	.078
FC0401	1-3/16	7/8	.078
FC0402	1-1/4	15/16	.078

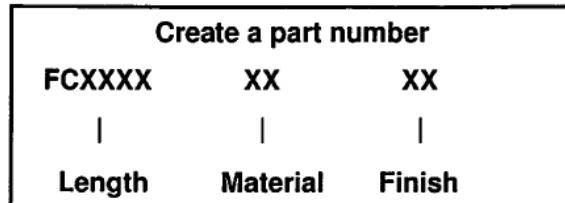

Material	
Material Code (XX)	
B	Brass
S	Steel
SS	Stainless Steel

See page 3 for finish codes



Fascomp Electronic Hardware
7814 Kingspointe Pkwy
Orlando, FL 32819
www.fascomp.com
Tel: (407) 326-2112

Fascomp Global Solutions

1-888-872-0690

<https://www.AngicGlobal.com> Sales@AngicGlobal.com



Get quote >>

Captive Screw Type 2 8-32 Thread

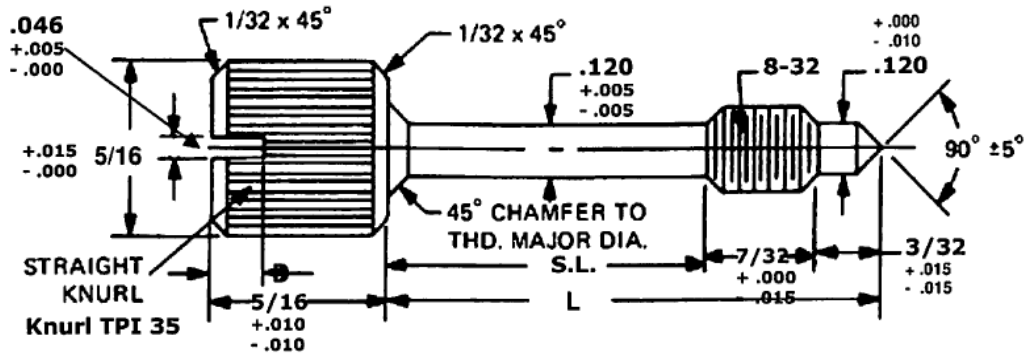

- Contact Sales Office for sizes not shown
- Source Control Drawing: To be produced by Fascomp Electronic Hardware

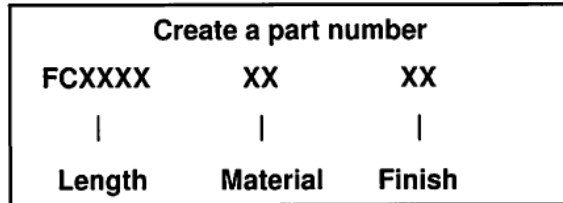

FCXXX	Length (L)	S.L. +.010 -.010	D. +.010 -.000
FC0403	7/16	1/8	.078
FC0404	1/2	3/16	.078
FC0405	9/16	1/4	.078
FC0406	5/8	5/16	.078
FC0407	11/16	3/8	.078
FC0408	3/4	7/16	.078
FC0409	13/16	1/2	.078
FC0410	7/8	9/16	.078
FC0411	15/16	5/8	.078
FC0412	1	11/16	.078
FC0413	1-1/16	3/4	.078
FC0414	1-1/8	13/16	.078
FC0415	1-3/16	7/8	.078
FC0416	1-1/4	15/16	.078

Material	
Material Code (XX)	
B	Brass
S	Steel
SS	Stainless Steel

See page 3 for finish codes



Fascomp Electronic Hardware
 7814 Kingspointe Pkwy
 Orlando, FL 32819
 www.fascomp.com
 Tel: (407) 226-2112
 Fax: (407) 226-2112



Get quote >>

Captive Screw Type 4 2-56 Thread

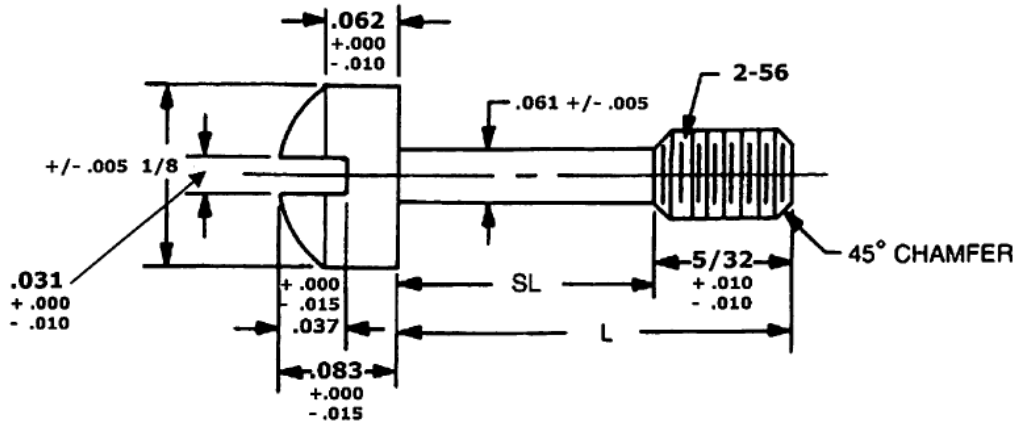

- Contact Sales Office for sizes not shown
- Source Control Drawing: To be produced by Fascomp Electronic Hardware

FCXXX	Length (L)	S.L. +/- .010
FC0799	1/4	3/32
FC0800	5/16	5/32
FC0801	3/8	7/32
FC0802	7/16	9/32
FC0803	1/2	11/32
FC0804	9/16	13/32
FC0805	5/8	15/32
FC0806	11/16	17/32
FC0807	3/4	19/32

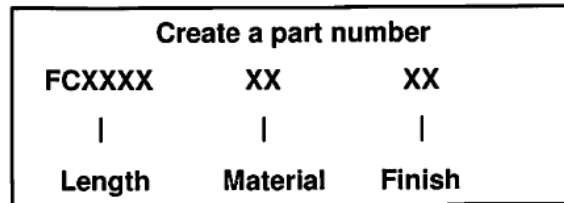

Material	
Material Code (XX)	
B	Brass
S	Steel
SS	Stainless Steel

See page 3 for finish codes



Captive Screws Type 4



Fascomp stocks type 4 Captive Screws in aluminum, brass, steel, and stainless steel.

	Page No.
2-56 Thread	40
3-48 Thread	41
4-40 Thread	42
6-32 Thread	43
8-32 Thread	44
10-24 Thread	45
10-32 Thread	46



Fascomp Electronic Hardware
7814 Kingspointe Pkwy
Orlando, FL 32819
www.fascomp.com
tel: (407) 226-2111



Get quote >>

Angic Global Solutions

1-888-872-0690

<https://www.AngicGlobal.com> Sales@AngicGlobal.com

Captive Screw Type 3 1/4-28 Thread

3/4 Head Diameter

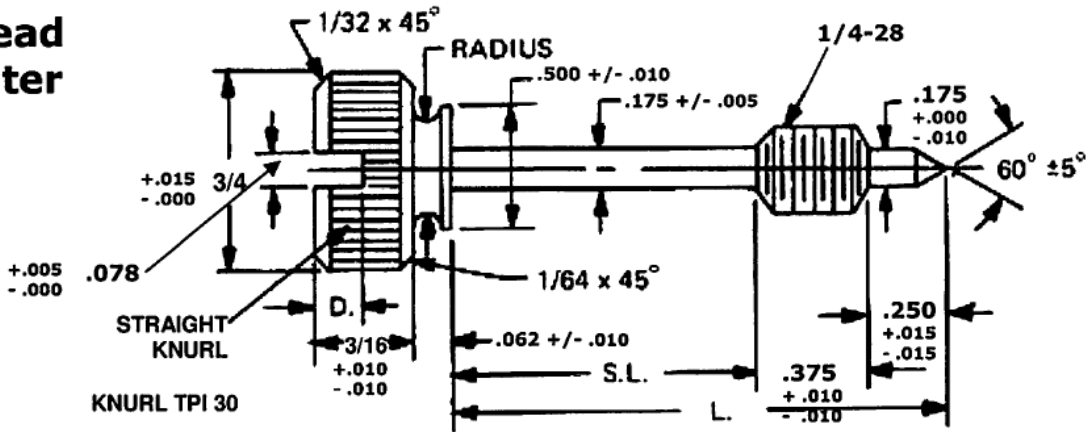

- Contact Sales Office for sizes not shown
- Source Control Drawing: To be produced by Fascomp Electronic Hardware

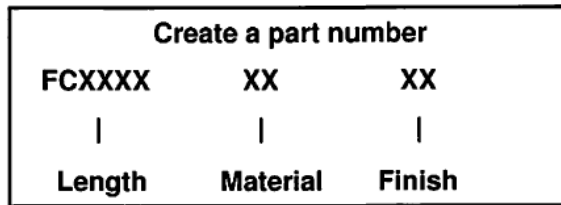

FCXXXX	Length (L)	S.L. +.010 -.010	D +.010 -.000
FC0782	3/4	1/8	.125
FC0783	13/16	3/16	.125
FC0784	7/8	1/4	.125
FC0785	15/16	5/16	.125
FC0786	1	3/8	.125
FC0787	1-1/16	7/16	.125
FC0788	1-1/8	1/2	.125
FC0790	1-3/16	9/16	.125
FC0790	1-1/4	5/8	.125
FC0791	1-5/16	11/16	.125
FC0792	1-3/8	3/4	.125
FC0793	1-7/16	13/16	.125
FC0794	1-1/2	7/8	.125
FC0795	1-9/16	15/16	.125
FC0796	1-5/8	1	.125
FC0797	1-11/16	1-1/16	.125
FC0798	1-3/4	1-1/8	.125

Material	
Material Code (XX)	
B	Brass
S	Steel
SS	Stainless Steel

See page 3 for finish codes



Fascomp Electronic Hardware
7814 Kingspointe Pkwy
Orlando, FL 32819
www.fascomp.com
Tel: (407) 251-1111
Fax: (407) 251-1112



Get quote >>

Captive Screw Type 3 1/4-28 Thread

5/8 Head Diameter

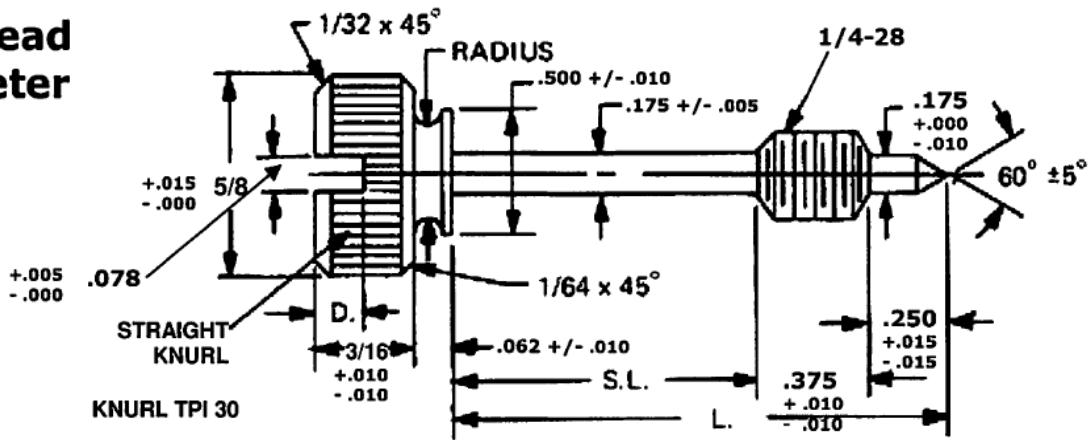

- Contact Sales Office for sizes not shown
- Source Control Drawing: To be produced by Fascomp Electronic Hardware

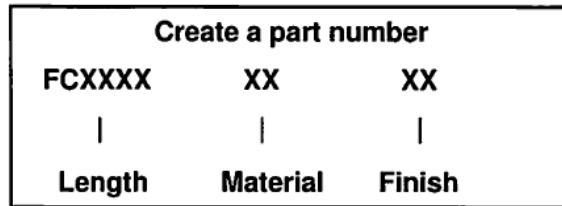

FCXXXX	Length (L)	S.L. + .010 - .010	D + .010 - .000
FC0765	3/4	1/8	.093
FC0766	13/16	3/16	.093
FC0767	7/8	1/4	.093
FC0768	15/16	5/16	.093
FC0769	1	3/8	.093
FC0770	1-1/16	7/16	.093
FC0771	1-1/8	1/2	.093
FC0772	1-3/16	9/16	.093
FC0773	1-1/4	5/8	.093
FC0774	1-5/16	11/16	.093
FC0775	1-3/8	3/4	.093
FC0776	1-7/16	13/16	.093
FC0777	1-1/2	7/8	.093
FC0778	1-9/16	15/16	.093
FC0779	1-5/8	1	.093
FC0780	1-11/16	1-1/16	.093
FC0781	1-3/4	1-1/8	.093

Material	
Material Code (XX)	
B	Brass
S	Steel
SS	Stainless Steel

See page 3 for finish codes



Fascomp Electronic Hardware
7814 Kingspointe Pkwy
Orlando, FL 32819
www.fascomp.com
Tel: (407) 222-2222
Fax: (407) 222-2222



Get quote >>

Angic Global Solutions

1-888-872-0690

<https://www.AngicGlobal.com> Sales@AngicGlobal.com

Captive Screw Type 3 1/4-20 Thread

3/4 Head Diameter

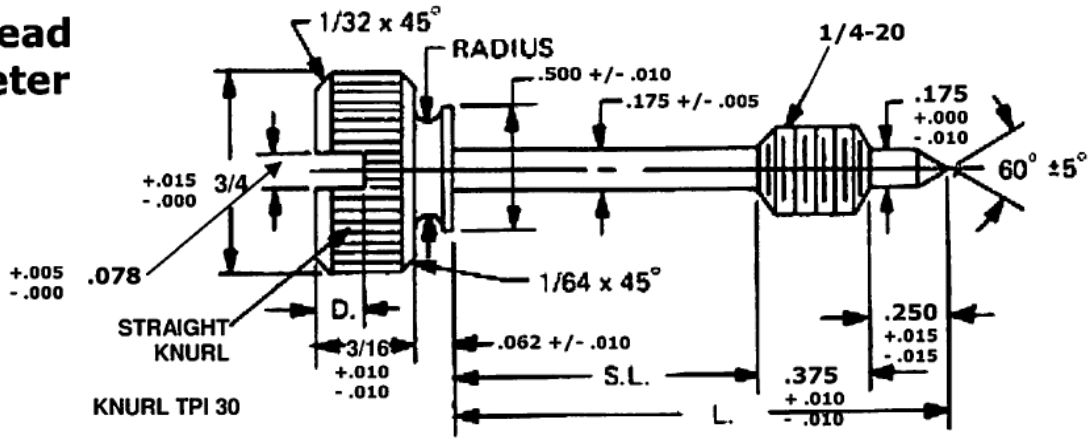

- Contact Sales Office for sizes not shown
- Source Control Drawing: To be produced by Fascomp Electronic Hardware

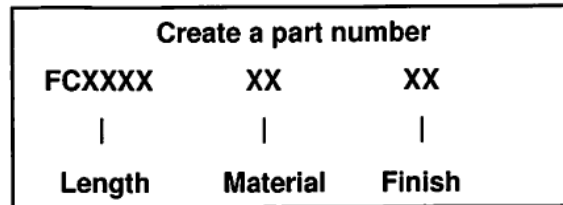

FCXXXX	Length (L)	S.L. +.010 -.010	D +.010 -.000
FC0748	3/4	1/8	.125
FC0749	13/16	3/16	.125
FC0750	7/8	1/4	.125
FC0751	15/16	5/16	.125
FC0752	1	3/8	.125
FC0753	1-1/16	7/16	.125
FC0754	1-1/8	1/2	.125
FC0755	1-3/16	9/16	.125
FC0756	1-1/4	5/8	.125
FC0757	1-5/16	11/16	.125
FC0758	1-3/8	3/4	.125
FC0759	1-7/16	13/16	.125
FC0760	1-1/2	7/8	.125
FC0761	1-9/16	15/16	.125
FC0762	1-5/8	1	.125
FC0763	1-11/16	1-1/16	.125
FC0764	1-3/4	1-1/8	.125

Material	
Material Code (XX)	
B	Brass
S	Steel
SS	Stainless Steel

See page 3 for finish codes



Fascomp Electronic Hardware
7814 Kingspointe Pkwy
Orlando, FL 32819
www.fascomp.com
Tel: (407) 226-2112
Fax: (407) 226-2113



Get quote >>

Captive Screw Type 3 1/4-20 Thread

5/8 Head Diameter

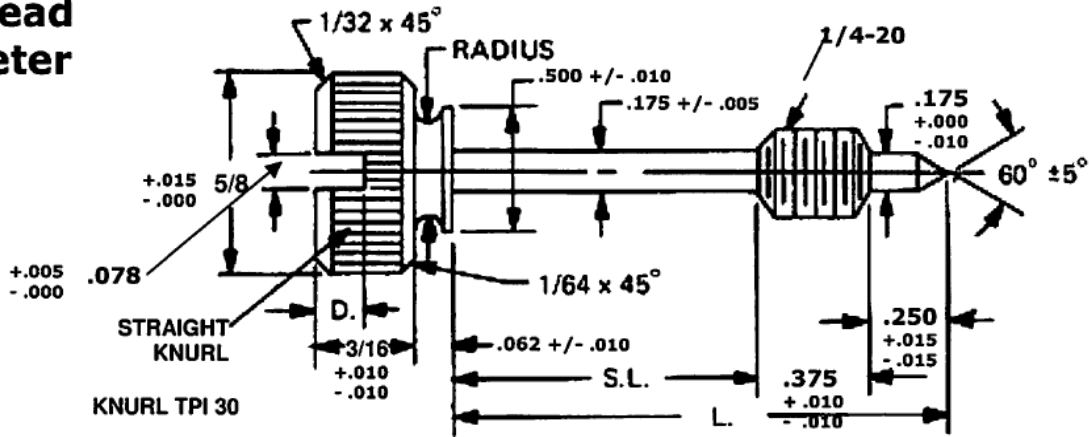

- Contact Sales Office for sizes not shown
- Source Control Drawing: To be produced by Fascomp Electronic Hardware

Create a part number

FCXXXX	XX	XX
Length	Material	Finish

FCXXXX	Length (L)	S.L. + .010 - .010	D + .010 - .000
FC0731	3/4	1/8	.093
FC0732	13/16	3/16	.093
FC0733	7/8	1/4	.093
FC0734	15/16	5/16	.093
FC0735	1	3/8	.093
FC0736	1-1/16	7/16	.093
FC0737	1-1/8	1/2	.093
FC0738	1-3/16	9/16	.093
FC0739	1-1/4	5/8	.093
FC0740	1-5/16	11/16	.093
FC0741	1-3/8	3/4	.093
FC0742	1-7/16	13/16	.093
FC0743	1-1/2	7/8	.093
FC0744	1-9/16	15/16	.093
FC0745	1-5/8	1	.093
FC0746	1-11/16	1-1/16	.093
FC0747	1-3/4	1-1/8	.093

Material	
Material Code (XX)	
B	Brass
S	Steel
SS	Stainless Steel

See page 3 for finish codes



Fascomp Electronic Hardware
 7814 Kingspointe Pkwy
 Orlando, FL 32819
 www.fascomp.com
 Tel: (407) 255-0111
 Fax: (407) 255-0111

ANGIC www.angic.com Get quote >>

Captive Screw Type 3 12-24 Thread

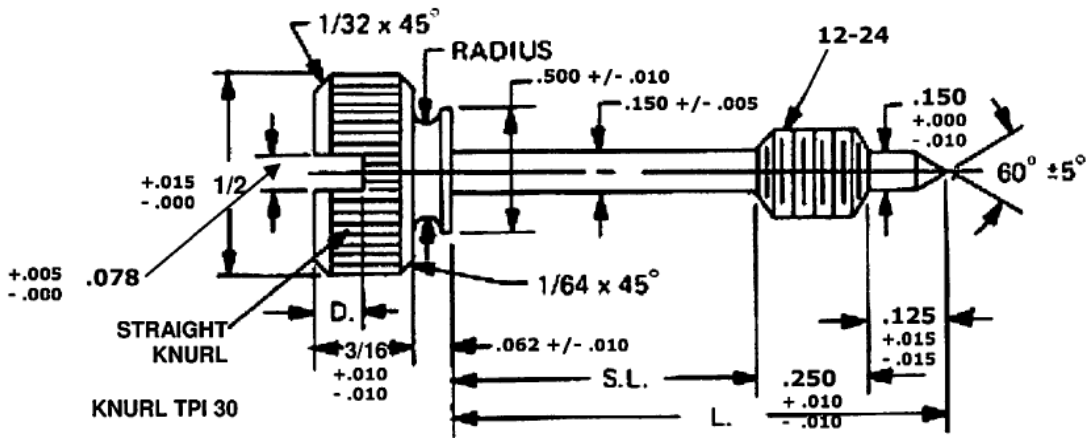

- Contact Sales Office for sizes not shown
- Source Control Drawing: To be produced by Fascomp Electronic Hardware

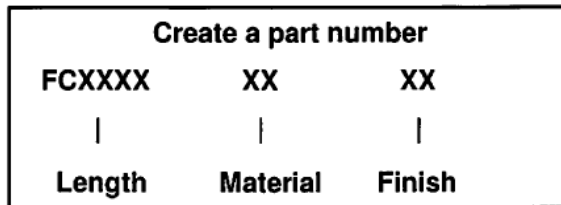

FCXXX	Length (L)	S.L. + .010 - .010	D + .010 - .000
FC0714	1/2	1/8	.093
FC0715	9/16	3/16	.093
FC0716	5/8	1/4	.093
FC0717	11/16	5/16	.093
FC0718	3/4	3/8	.093
FC0719	13/16	7/16	.093
FC0720	7/8	1/2	.093
FC0721	15/16	9/16	.093
FC0722	1	5/8	.093
FC0723	1-1/16	11/16	.093
FC0724	1-1/8	3/4	.093
FC0725	1-3/16	13/16	.093
FC0726	1-1/4	7/8	.093
FC0727	1-5/16	15/16	.093
FC0728	1-3/8	1	.093
FC0729	1-7/16	1-1/16	.093
FC0730	1-1/2	1-1/8	.093

Material	
Material Code (XX)	
B	Brass
S	Steel
SS	Stainless Steel

See page 3 for finish codes



Fascomp Electronic Hardware
 7814 Kingspointe Pkwy
 Orlando, FL 32819
 www.fascomp.com
 Tel: (407) 2...
 Fax: (407) 2...



Captive Screw Type 3 10-32 Thread

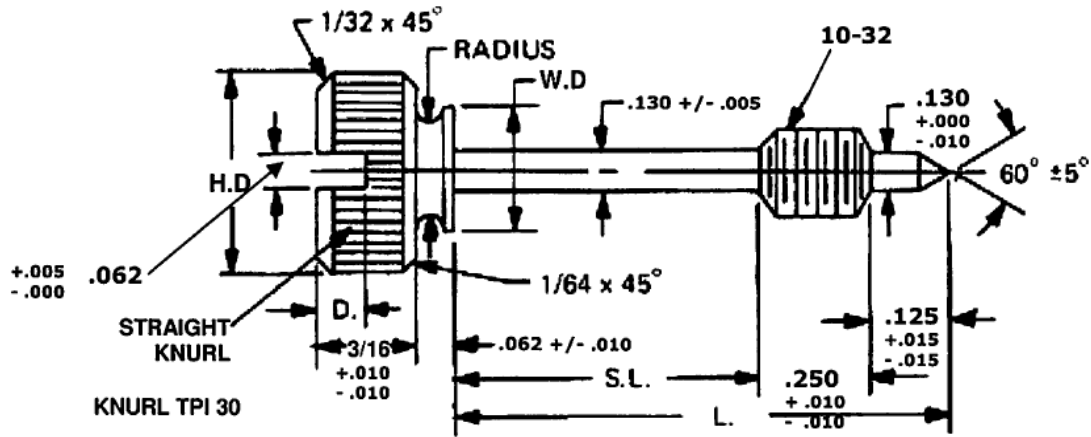

FCXXXX	Length (L)	H.D. + .015 - .000	S.L. + .010 - .010	W.D. + .010 - .010	D + .010 - .000
FC0680	1/2	1/2	1/8	.406	.093
FC0681	9/16	1/2	3/16	.406	.093
FC0682	5/8	1/2	1/4	.406	.093
FC0683	11/16	1/2	5/16	.406	.093
FC0684	3/4	1/2	3/8	.406	.093
FC0685	13/16	1/2	7/16	.406	.093
FC0686	7/8	1/2	1/2	.406	.093
FC0687	15/16	1/2	9/16	.406	.093
FC0688	1	1/2	5/8	.406	.093
FC0689	1-1/16	1/2	11/16	.406	.093
FC0690	1-1/8	1/2	3/4	.406	.093
FC0691	1-3/16	1/2	13/16	.406	.093
FC0692	1-1/4	1/2	7/8	.406	.093
FC0693	1-5/16	1/2	15/16	.406	.093
FC0694	1-3/8	1/2	1	.406	.093
FC0695	1-7/16	1/2	1-1/16	.406	.093
FC0696	1-1/2	1/2	1-1/8	.406	.093
FC0697	1/2	5/8	1/8	.500	.093
FC0698	9/16	5/8	3/16	.500	.093
FC0699	5/8	5/8	1/4	.500	.093
FC0700	11/16	5/8	5/16	.500	.093
FC0701	3/4	5/8	3/8	.500	.093
FC0702	13/16	5/8	7/16	.500	.093
FC0703	7/8	5/8	1/2	.500	.093
FC0704	15/16	5/8	9/16	.500	.093
FC0705	1	5/8	5/8	.500	.093
FC0706	1-1/16	5/8	11/16	.500	.093
FC0707	1-1/8	5/8	3/4	.500	.093
FC0708	1-3/16	5/8	13/16	.500	.093
FC0709	1-1/4	5/8	7/8	.500	.093
FC0710	1-5/16	5/8	15/16	.500	.093
FC0711	1-3/8	5/8	1	.500	.093
FC0712	1-7/16	5/8	1-1/16	.500	.093
FC0713					

- Contact Sales Office for sizes not shown
- Source Control Drawing: To be produced by Fascomp Electronic Hardware

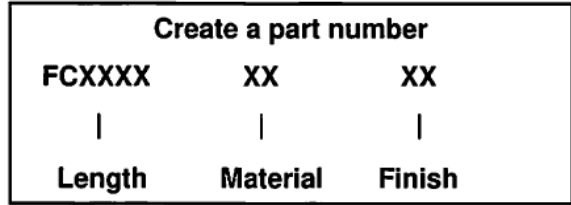

Material	
Material Code (XX)	
B	Brass
S	Steel
SS	Stainless Steel

See page 3 for finish codes



Fascomp Electronic Hardware
7814 Kingspointe Pkwy
Orlando, FL 32819
www.fascomp.com
Tel: (407) 226-3113



Get quote >>

Captive Screw Type 3 10-24 Thread

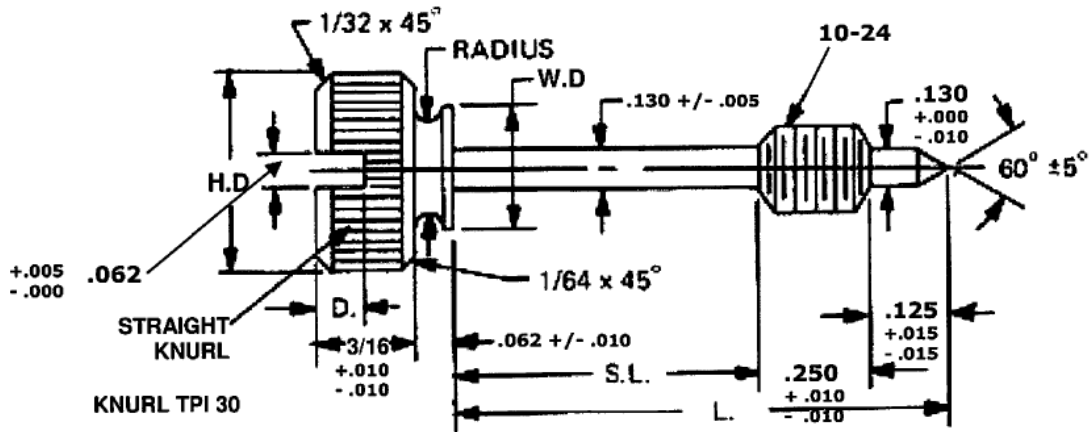

FCXXXX	Length (L)	H.D. + .015 - .000	S.L. + .010 - .010	W.D. + .010 - .010	D + .010 - .000
FC0646	1/2	1/2	1/8	.406	.093
FC0647	9/16	1/2	3/16	.406	.093
FC0648	5/8	1/2	1/4	.406	.093
FC0649	11/16	1/2	5/16	.406	.093
FC0650	3/4	1/2	3/8	.406	.093
FC0651	13/16	1/2	7/16	.406	.093
FC0652	7/8	1/2	1/2	.406	.093
FC0653	15/16	1/2	9/16	.406	.093
FC0654	1	1/2	5/8	.406	.093
FC0655	1-1/16	1/2	11/16	.406	.093
FC0656	1-1/8	1/2	3/4	.406	.093
FC0657	1-3/16	1/2	13/16	.406	.093
FC0658	1-1/4	1/2	7/8	.406	.093
FC0659	1-5/16	1/2	15/16	.406	.093
FC0660	1-3/8	1/2	1	.406	.093
FC0661	1-7/16	1/2	1-1/16	.406	.093
FC0662	1-1/2	1/2	1-1/8	.406	.093
FC0663	1/2	5/8	1/8	.500	.093
FC0664	9/16	5/8	3/16	.500	.093
FC0665	5/8	5/8	1/4	.500	.093
FC0666	11/16	5/8	5/16	.500	.093
FC0667	3/4	5/8	3/8	.500	.093
FC0668	13/16	5/8	7/16	.500	.093
FC0669	7/8	5/8	1/2	.500	.093
FC0670	15/16	5/8	9/16	.500	.093
FC0671	1	5/8	5/8	.500	.093
FC0672	1-1/16	5/8	11/16	.500	.093
FC0673	1-1/8	5/8	3/4	.500	.093
FC0674	1-3/16	5/8	13/16	.500	.093
FC0675	1-1/4	5/8	7/8	.500	.093
FC0676	1-5/16	5/8	15/16	.500	.093
FC0677	1-3/8	5/8	1	.500	.093
FC0678	1-7/16	5/8	1-1/16	.500	.093
FC0679	1-1/2	5/8	1-1/8	.500	.093

- Contact Sales Office for sizes not shown
- Source Control Drawing: To be produced by Fascomp Electronic Hardware

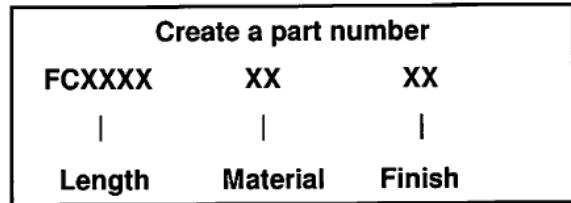

Material	
Material Code (XX)	
B	Brass
S	Steel
SS	Stainless Steel

See page 3 for finish codes



Fascomp Electronic Hardware
7814 Kingspointe Pkwy
Orlando, FL 32819
www.fascomp.com



Captive Screw Type 3 6-32 Thread

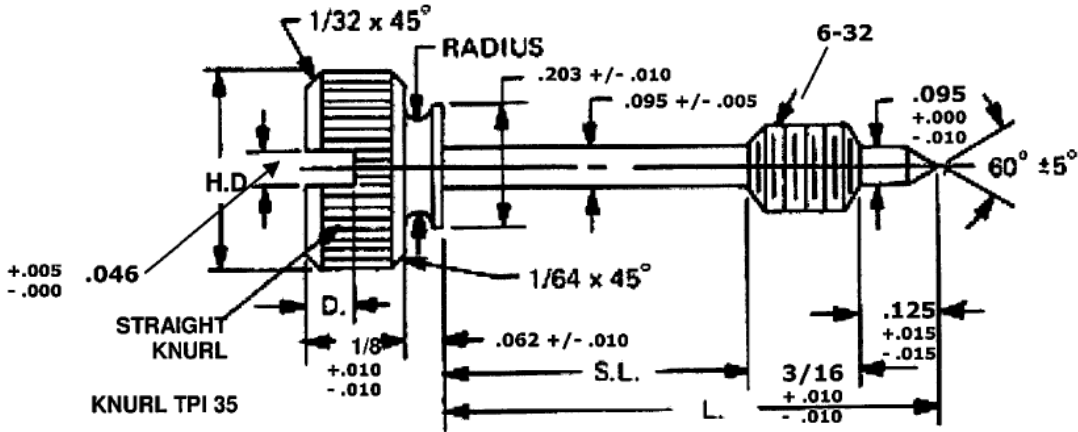

- Contact Sales Office for sizes not shown
- Source Control Drawing: To be produced by Fascomp Electronic Hardware

FCXXX	Length (L)	H.D. + .015 - .000	S.L. +/- .010	D + .010 - .000
FC0586	1/2	5/16	3/16	.062
FC0587	9/16	5/16	1/4	.062
FC0588	5/8	5/16	5/16	.062
FC0589	11/16	5/16	3/8	.062
FC0590	3/4	5/16	7/16	.062
FC0591	13/16	5/16	1/2	.062
FC0592	7/8	5/16	9/16	.062
FC0593	15/16	5/16	5/8	.062
FC0594	1	5/16	11/16	.062
FC0595	1-1/16	5/16	3/4	.062
FC0596	1-1/8	5/16	13/16	.062
FC0597	1-3/16	5/16	7/8	.062
FC0598	1-1/4	5/16	15/16	.062
FC0599	1/2	3/8	3/16	.062
FC0600	9/16	3/8	1/4	.062
FC0601	5/8	3/8	5/16	.062
FC0602	11/16	3/8	3/8	.062
FC0603	3/4	3/8	7/16	.062
FC0604	13/16	3/8	1/2	.062
FC0605	7/8	3/8	9/16	.062
FC0606	15/16	3/8	5/8	.062
FC0607	1	3/8	11/16	.062
FC0608	1-1/16	3/8	3/4	.062
FC0609	1-1/8	3/8	13/16	.062
FC0610	1-3/16	3/8	7/8	.062
FC0611	1-1/4	3/8	15/16	.062

Create a part number

FCXXX	XX	XX
Length	Material	Finish

Material	
Material Code (XX)	
B	Brass
S	Steel
SS	Stainless Steel

See page 3 for finish codes



Fascomp Electronic Hardware
 7814 Kingspointe Pkwy
 Orlando, FL 32819
 www.fascomp.com
 Tel: (407) 226-2112
 Fax: (407) 226-3370



Get quote >>

Captive Screw Type 3 4-40 Thread

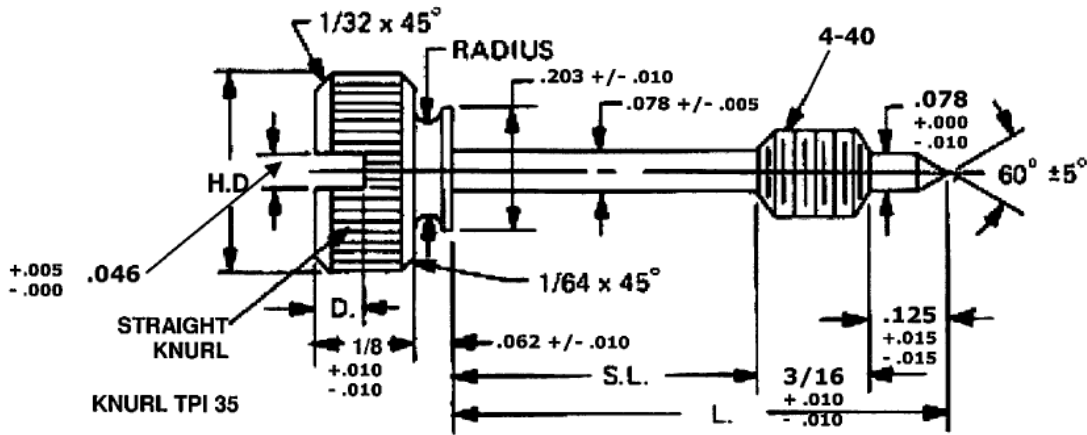

- Contact Sales Office for sizes not shown
- Source Control Drawing: To be produced by Fascomp Electronic Hardware

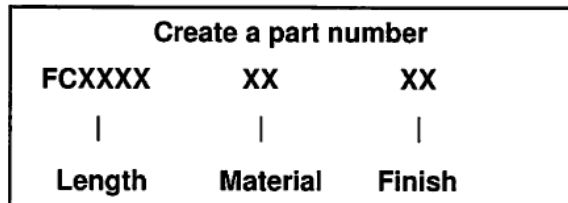

FCXXXX	Length (L)	H.D. + .015 - .000	S.L. +/- .010	D + .010 - .000
FC0568	1/2	1/4	3/16	.062
FC0569	9/16	1/4	1/4	.062
FC0570	5/8	1/4	5/16	.062
FC0571	11/16	1/4	3/8	.062
FC0572	3/4	1/4	7/16	.062
FC0573	13/16	1/4	1/2	.062
FC0574	7/8	1/4	9/16	.062
FC0575	15/16	1/4	5/8	.062
FC0576	1	1/4	11/16	.062
FC0577	1/2	5/16	3/16	.062
FC0578	9/16	5/16	1/4	.062
FC0579	5/8	5/16	5/16	.062
FC0580	11/16	5/16	3/8	.062
FC0581	3/4	5/16	7/16	.062
FC0582	13/16	5/16	1/2	.062
FC0583	7/8	5/16	9/16	.062
FC0584	15/16	5/16	5/8	.062
FC0585	1	5/16	11/16	.062

Material	
Material Code (XX)	
B	Brass
S	Steel
SS	Stainless Steel

See page 3 for finish codes



Fascomp Electronic Hardware
 7814 Kingspointe Pkwy
 Orlando, FL 32819
 www.fascomp.com
 Tel: (407) 226-3112

Fa Angic Global Solutions

1-888-872-0690 9

<https://www.AngicGlobal.com> Sales@AngicGlobal.com



Get quote >>



Captive Screws Type 3



Fascomp stocks type 3 Captive Screws in aluminum, brass, steel, and stainless steel.

	Page No.
4-40 Thread	29
6-32 Thread	30
8-32 Thread	31
10-24 Thread	32
10-32 Thread	33
12-24 Thread	34
1/4-20 Thread - 5/8 H.D.	35
1/4-20 Thread - 3.4 H.D.	36
1/4-28 Thread - 5/8 H.D.	37
1/4-28 Thread - 3.4 H.D.	38

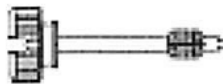

Fascomp Electronic Hardware
7814 Kingspointe Pkwy
Orlando, FL 32819
www.fascomp.com
el: (407) 226-211



Captive Screw Type 2 3/8-16 Thread

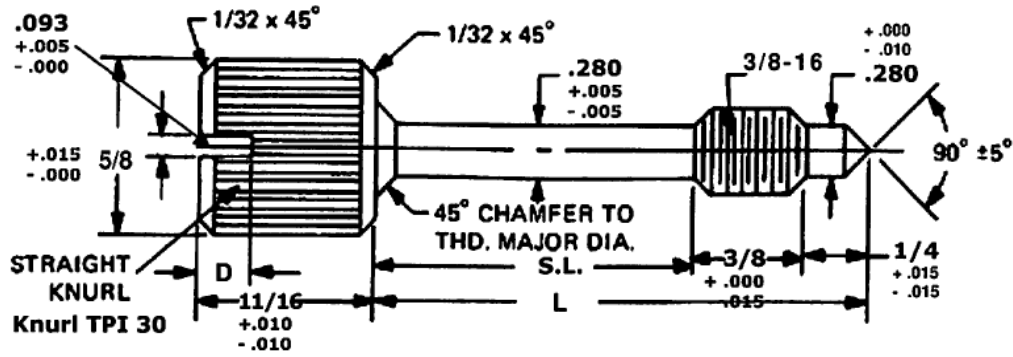

- Contact Sales Office for sizes not shown
- Source Control Drawing: To be produced by Fascomp Electronic Hardware

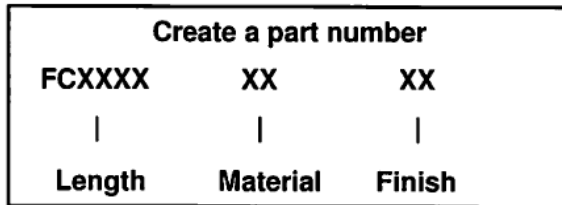

FCXXX	Length (L)	S.L. +.010 -.010	D. +.010 -.000
FC0551	1	3/8	.125
FC0552	1-1/16	7/16	.125
FC0553	1-1/8	1/2	.125
FC0554	1-3/16	9/16	.125
FC0555	1-1/4	5/8	.125
FC0556	1-5/16	11/16	.125
FC0557	1-3/8	3/4	.125
FC0558	1-7/16	13/16	.125
FC0559	1-1/2	7/8	.125
FC0560	1-9/16	15/16	.125
FC0561	1-5/8	1	.125
FC0562	1-11/16	1-1/16	.125
FC0563	1-3/4	1-1/8	.125
FC0564	1-13/16	1-3/16	.125
FC0565	1-7/8	1-1/4	.125
FC0566	1-15/16	1-5/16	.125
FC0567	2	1-3/8	.125

Material	
Material Code (XX)	
B	Brass
S	Steel
SS	Stainless Steel

See page 3 for finish codes



Fascomp Electronic Hardware
7814 Kingspointe Pkwy
Orlando, FL 32819
www.fascomp.com
Tel: (407) 222-2222
Fax: (407) 222-2222



Get quote »

Angic Global Solutions

1-888-872-0690

<https://www.AngicGlobal.com> Sales@AngicGlobal.com

Captive Screw Type 2 5/16-24 Thread

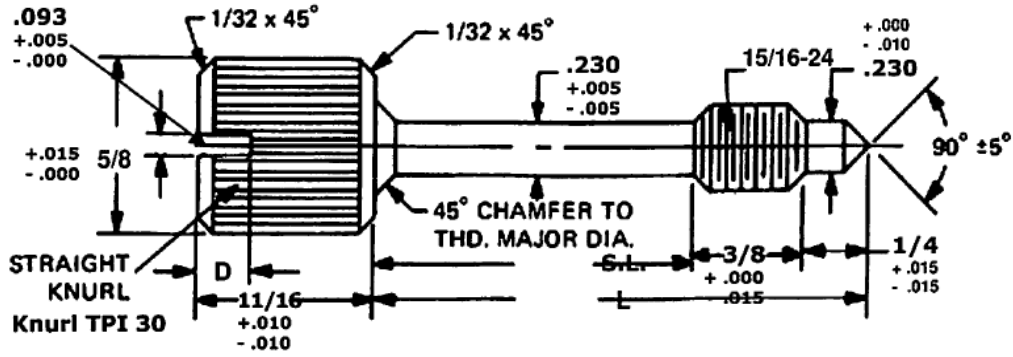

- Contact Sales Office for sizes not shown
- Source Control Drawing: To be produced by Fascomp Electronic Hardware

FCXXXX	Length (L)	S.L. +.010 -.010	D. +.010 -.000
FC0532	7/8	1/4	.125
FC0533	15/16	5/16	.125
FC0534	1	3/8	.125
FC0535	1-1/16	7/16	.125
FC0536	1-1/8	1/2	.125
FC0537	1-3/16	9/16	.125
FC0538	1-1/4	5/8	.125
FC0539	1-5/16	11/16	.125
FC0540	1-3/8	3/4	.125
FC0541	1-7/16	13/16	.125
FC0542	1-1/2	7/8	.125
FC0543	1-9/16	15/16	.125
FC0544	1-5/8	1	.125
FC0545	1-11/16	1-1/16	.125
FC0546	1-3/4	1-1/8	.125
FC0547	1-13/16	1-3/16	.125
FC0548	1-7/8	1-1/4	.125
FC0549	1-15/16	1-5/16	.125
FC0550	2	1-3/8	.125

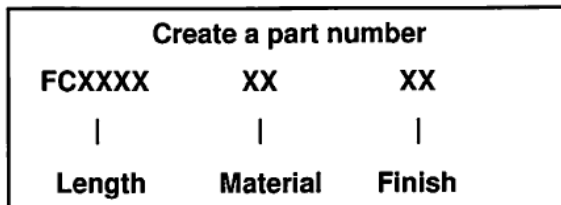

Material	
Material Code (XX)	
B	Brass
S	Steel
SS	Stainless Steel

See page 3 for finish codes



Fascomp Electronic Hardware
 7814 Kingspointe Pkwy
 Orlando, FL 32819
 www.fascomp.com
 Tel: (407) 226-2112
 Fax: (407) 226-3370



Get quote >>

Captive Screw Type 2 5/16-18 Thread

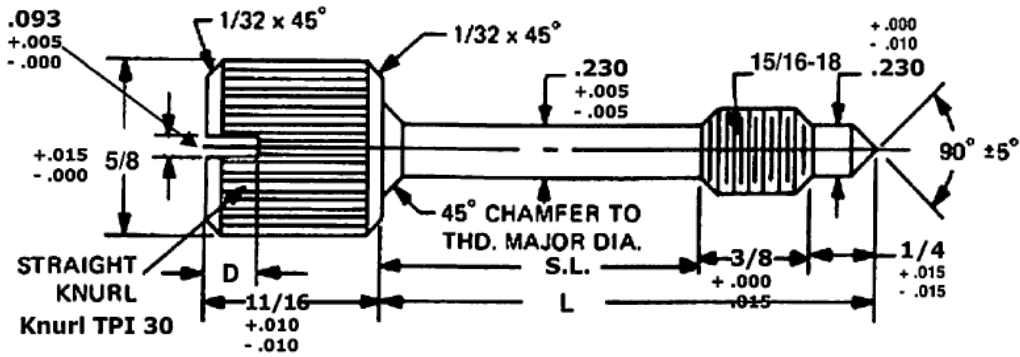

- Contact Sales Office for sizes not shown
- Source Control Drawing: To be produced by Fascomp Electronic Hardware

FCXXX	Length (L)	S.L. +.010 -.010	D. +.010 -.000
FC0513	7/8	1/4	.125
FC0514	15/16	5/16	.125
FC0515	1	3/8	.125
FC0516	1-1/16	7/16	.125
FC0517	1-1/8	1/2	.125
FC0518	1-3/16	9/16	.125
FC0519	1-1/4	5/8	.125
FC0520	1-5/16	11/16	.125
FC0521	1-3/8	3/4	.125
FC0522	1-7/16	13/16	.125
FC0523	1-1/2	7/8	.125
FC0524	1-9/16	15/16	.125
FC0525	1-5/8	1	.125
FC0526	1-11/16	1-1/16	.125
FC0527	1-3/4	1-1/8	.125
FC0528	1-13/16	1-3/16	.125
FC0529	1-7/8	1-1/4	.125
FC0530	1-15/16	1-5/16	.125
FC0531	2	1-3/8	.125

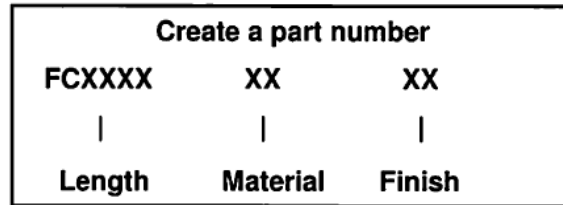

Material	
Material Code (XX)	
B	Brass
S	Steel
SS	Stainless Steel

See page 3 for finish codes



Fascomp Electronic Hardware
7814 Kingspointe Pkwy
Orlando, FL 32819
www.fascomp.com
Tel: (407) 226-2112
Fax: (407) 226-2370



Get quote >>

Angic Global Solutions

1-888-872-0690

<https://www.AngicGlobal.com> Sales@AngicGlobal.com

Captive Screw Type 2 1/4-28 Thread

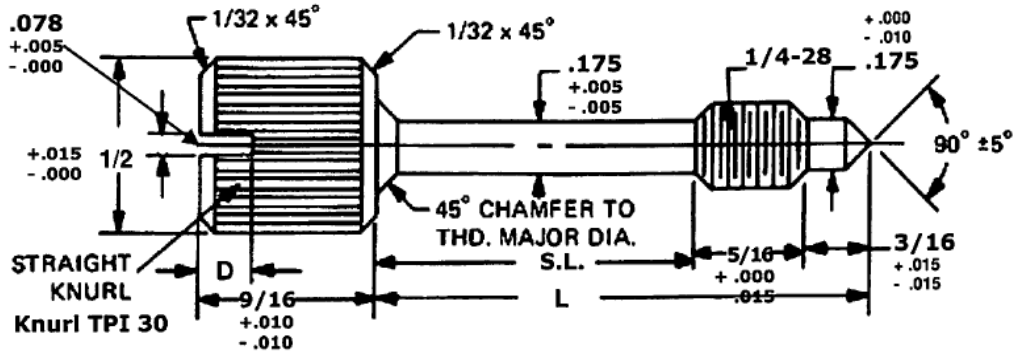

- Contact Sales Office for sizes not shown
- Source Control Drawing: To be produced by Fascomp Electronic Hardware

FCXXX	Length (L)	S.L. +.010 -.010	D. +.010 -.000
FC0490	5/8	1/8	.093
FC0491	11/16	3/16	.093
FC0492	3/4	1/4	.093
FC0493	13/16	5/16	.093
FC0494	7/8	3/8	.093
FC0495	15/16	7/16	.093
FC0496	1	1/2	.093
FC0497	1-1/16	9/16	.093
FC0498	1-1/8	5/8	.093
FC0499	1-3/16	11/16	.093
FC0500	1-1/4	3/4	.093
FC0501	1-5/16	13/16	.093
FC0502	1-3/8	7/8	.093
FC0503	1-7/16	15/16	.093
FC0504	1-1/2	1	.093
FC0505	1-9/16	1-1/6	.093
FC0506	1-5/8	1-1/8	.093
FC0507	1-11/16	1-3/16	.093
FC0508	1-3/4	1-1/4	.093
FC0509	1-13/16	1-5/16	.093
FC0510	1-7/8	1-3/8	.093
FC0511	1-15/16	1-7/16	.093
FC0512	2	1-1/2	.093

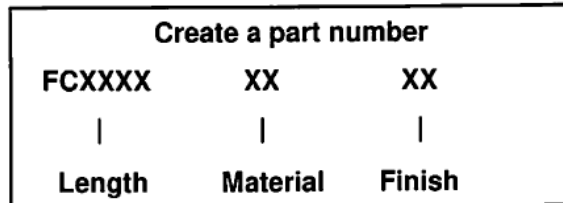

Material	
Material Code (XX)	
B	Brass
S	Steel
SS	Stainless Steel

See page 3 for finish codes



Fascomp Electronic Hardware
 7814 Kingspointe Pkwy
 Orlando, FL 32819
 www.fascomp.com
 Tel: (407)
 Fax: (407)

Angic Global Solutions 1-888-872-0690
<https://www.AngicGlobal.com> Sales@AngicGlobal.com



Captive Screw Type 2 1/4-20 Thread

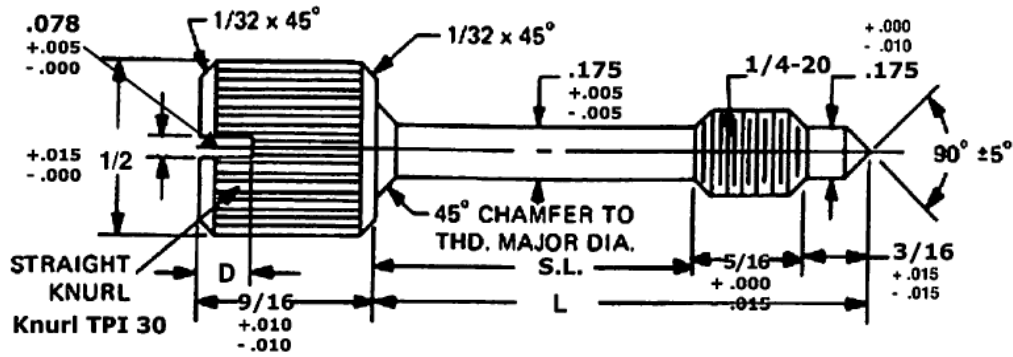

- Contact Sales Office for sizes not shown
- Source Control Drawing: To be produced by Fascomp Electronic Hardware

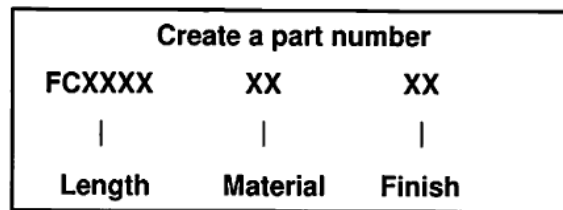

FCXXXX	Length (L)	S.L. +.010 -.010	D. +.010 -.000
FC0467	5/8	1/8	.093
FC0468	11/16	3/16	.093
FC0469	3/4	1/4	.093
FC0470	13/16	5/16	.093
FC0471	7/8	3/8	.093
FC0472	15/16	7/16	.093
FC0473	1	1/2	.093
FC0474	1-1/16	9/16	.093
FC0475	1-1/8	5/8	.093
FC0476	1-3/16	11/16	.093
FC0477	1-1/4	3/4	.093
FC0478	1-5/16	13/16	.093
FC0479	1-3/8	7/8	.093
FC0480	1-7/16	15/16	.093
FC0481	1-1/2	1	.093
FC0482	1-9/16	1-1/6	.093
FC0483	1-5/8	1-1/8	.093
FC0484	1-11/16	1-3/16	.093
FC0485	1-3/4	1-1/4	.093
FC0486	1-13/16	1-5/16	.093
FC0487	1-7/8	1-3/8	.093
FC0488	1-15/16	1-7/16	.093
FC0489	2	1-1/2	.093

Material	
Material Code (XX)	
B	Brass
S	Steel
SS	Stainless Steel

See page 3 for finish codes



Fascomp Electronic Hardware
7814 Kingspointe Pkwy
Orlando, FL 32819
www.fascomp.com
Tel: (407) 222-2111
Fax: (407) 222-2111



Get quote >>

Angic Global Solutions

1-888-872-0690 3

<https://www.AngicGlobal.com> Sales@AngicGlobal.com

Captive Screw Type 2 10-32 Thread

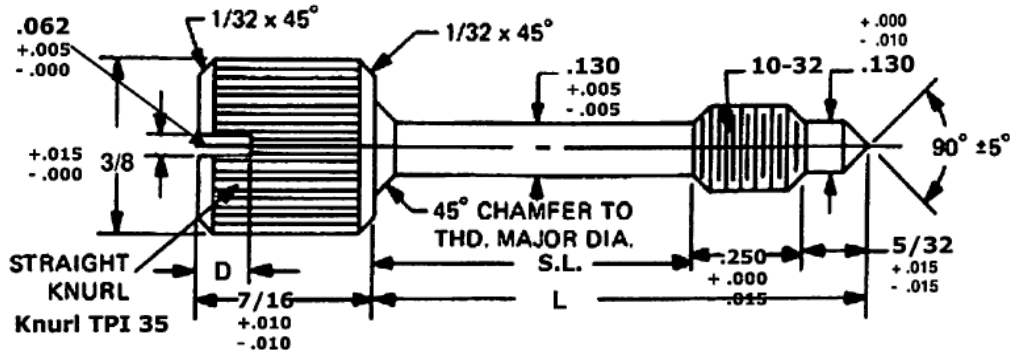

- Contact Sales Office for sizes not shown
- Source Control Drawing: To be produced by Fascomp Electronic Hardware

FCXXXX	Length (L)	S.L. +.010 -.010	D. +.010 -.000
FC0442	1/2	3/32	.093
FC0443	9/16	5/32	.093
FC0444	5/8	7/32	.093
FC0445	11/16	9/32	.093
FC0446	3/4	11/32	.093
FC0447	13/16	13/32	.093
FC0448	7/8	15/32	.093
FC0449	15/16	17/32	.093
FC0450	1	19/32	.093
FC0451	1-1/16	21/32	.093
FC0452	1-1/8	23/32	.093
FC0453	1-3/16	25/32	.093
FC0454	1-1/4	27/32	.093
FC0455	1-5/16	29/32	.093
FC0456	1-3/8	31/32	.093
FC0457	1-7/16	1-1/32	.093
FC0458	1-1/2	1-3/32	.093
FC0459	1-9/16	1-5/32	.093
FC0460	1-5/8	1-7/32	.093
FC0461	1-11/16	1-9/32	.093
FC0462	1-3/4	1-11/32	.093
FC0463	1-13/16	1-13/32	.093
FC0464	1-7/8	1-15/32	.093
FC0465	1-15/16	1-17/32	.093
FC0466	2	1-19/32	.093

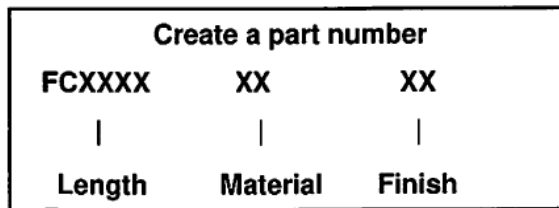

Material	
Material Code (XX)	
B	Brass
S	Steel
SS	Stainless Steel

See page 3 for finish codes



Fascomp Electronic Hardware
 7814 Kingspointe Pkwy
 Orlando, FL 32819
 www.fascomp.com
 Tel: (407) 326-2112
 Fax: (407) 326-2112



Captive Screw Type 2 10-24 Thread

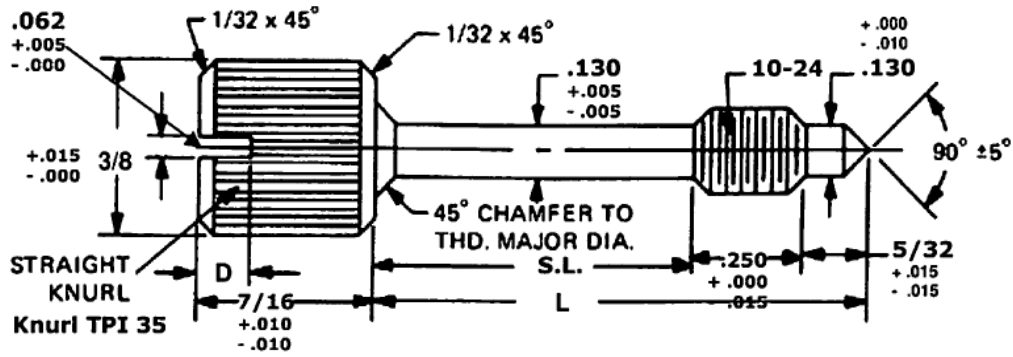

- Contact Sales Office for sizes not shown
- Source Control Drawing: To be produced by Fascomp Electronic Hardware

FCXXX	Length (L)	S.L. +.010 -.010	D. +.010 -.000
FC0417	1/2	3/32	.093
FC0418	9/16	5/32	.093
FC0419	5/8	7/32	.093
FC0420	11/16	9/32	.093
FC0421	3/4	11/32	.093
FC0422	13/16	13/32	.093
FC0423	7/8	15/32	.093
FC0424	15/16	17/32	.093
FC0425	1	19/32	.093
FC0426	1-1/16	21/32	.093
FC0427	1-1/8	23/32	.093
FC0428	1-3/16	25/32	.093
FC0429	1-1/4	27/32	.093
FC0430	1-5/16	29/32	.093
FC0431	1-3/8	31/32	.093
FC0432	1-7/16	1-1/32	.093
FC0433	1-1/2	1-3/32	.093
FC0434	1-9/16	1-5/32	.093
FC0435	1-5/8	1-7/32	.093
FC0436	1-11/16	1-9/32	.093
FC0437	1-3/4	1-11/32	.093
FC0438	1-13/16	1-13/32	.093
FC0439	1-7/8	1-15/32	.093
FC0440	1-15/16	1-17/32	.093
FC0441	2	1-19/32	.093

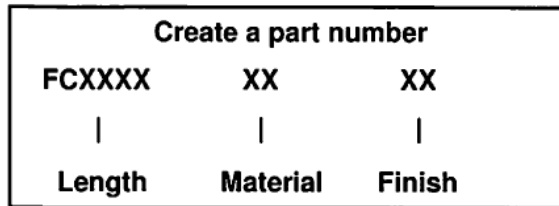

Material	
Material Code (XX)	
B	Brass
S	Steel
SS	Stainless Steel

See page 3 for finish codes



Fascomp Electronic Hardware
 7814 Kingspointe Pkwy
 Orlando, FL 32819
 www.fascomp.com
 Tel: (407) 251-1111
 Fax: (407) 251-1112



Get quote >>

Angic Global Solutions

1-888-872-0690

<https://www.AngicGlobal.com> Sales@AngicGlobal.com

Captive Screw Type 4 3-48 Thread

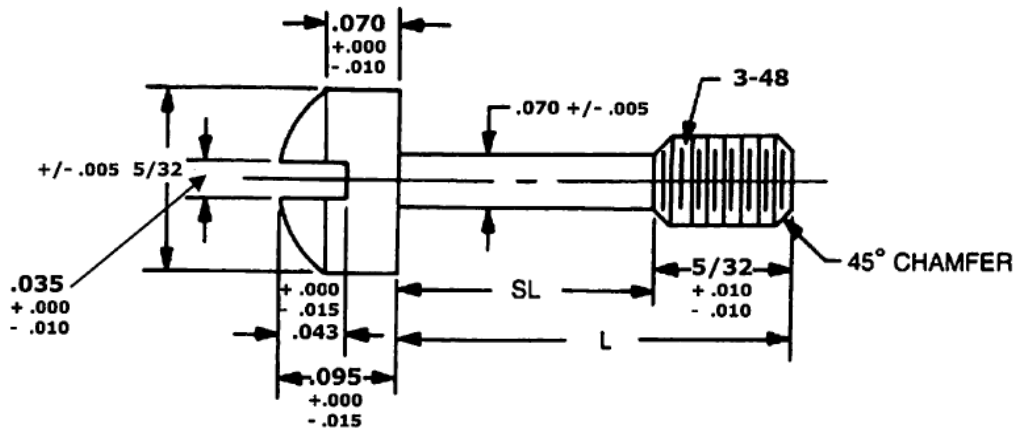

- Contact Sales Office for sizes not shown
- Source Control Drawing: To be produced by Fascomp Electronic Hardware

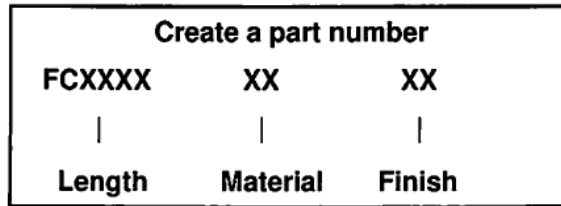

FCXXX	Length (L)	S.L. +/- .010
FC0808	1/4	3/32
FC0809	5/16	5/32
FC0810	3/8	7/32
FC0811	7/16	9/32
FC0812	1/2	11/32
FC0813	9/16	13/32
FC0814	5/8	15/32
FC0815	11/16	17/32
FC0816	3/4	19/32

Material	
Material Code (XX)	
B	Brass
S	Steel
SS	Stainless Steel

See page 3 for finish codes



Fascomp Electronic Hardware
 7814 Kingspointe Pkwy
 Orlando, FL 32819
 www.fascomp.com
 Tel: (407) 276-2112
 Fax: (407) 276-2112



Get quote >>

Angic Global Solutions

1-888-872-0690

<https://www.AngicGlobal.com> Sales@AngicGlobal.com

Captive Screw Type 4 4-40 Thread

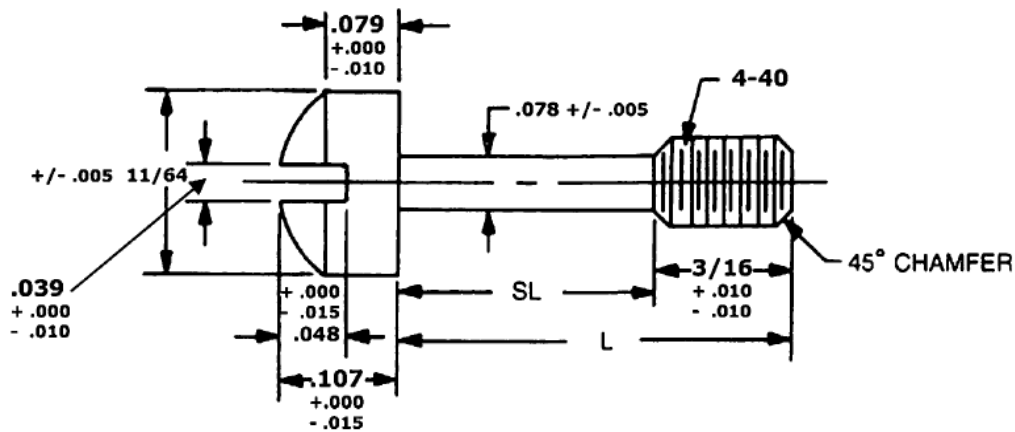

- Contact Sales Office for sizes not shown
- Source Control Drawing: To be produced by Fascomp Electronic Hardware

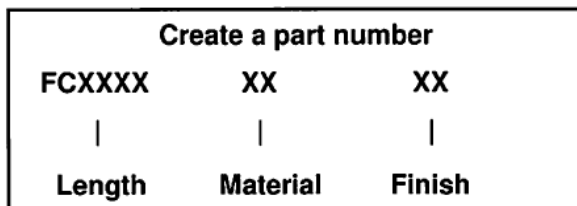

FCXXX	Length (L)	S.L. +/- .010
FC0817	1/4	1/16
FC0818	5/16	1/8
FC0819	3/8	3/16
FC0820	7/16	1/4
FC0821	1/2	5/16
FC0822	9/16	3/8
FC0823	5/8	7/16
FC0824	11/16	1/2
FC0825	3/4	9/16
FC0826	13/16	5/8
FC0827	7/8	11/16
FC0828	15/16	3/4
FC0829	1	13/16

Material	
Material Code (XX)	
B	Brass
S	Steel
SS	Stainless Steel

See page 3 for finish codes



Fascomp Electronic Hardware
 7814 Kingspointe Pkwy
 Orlando, FL 32819
 www.fascomp.com
 Tel: (407) 226-2112
 Fax: (407) :



Get quote >>

Captive Screw Type 4 6-32 Thread

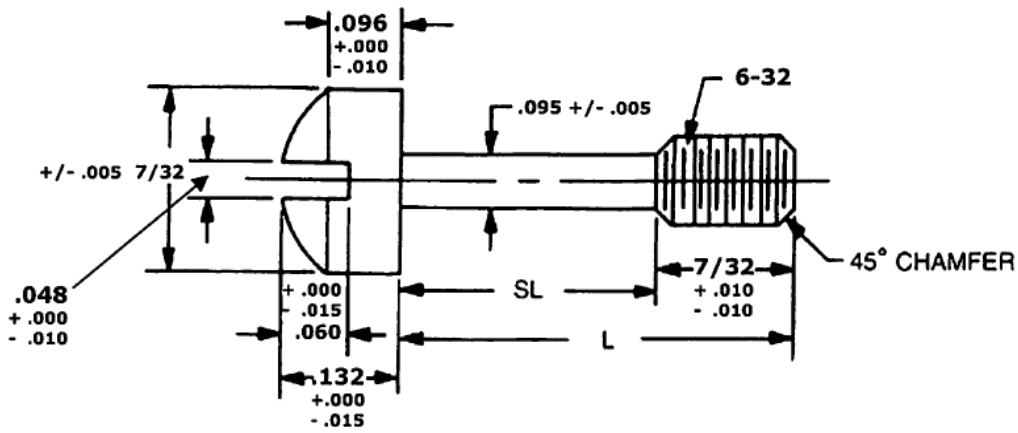

- Contact Sales Office for sizes not shown
- Source Control Drawing: To be produced by Fascomp Electronic Hardware

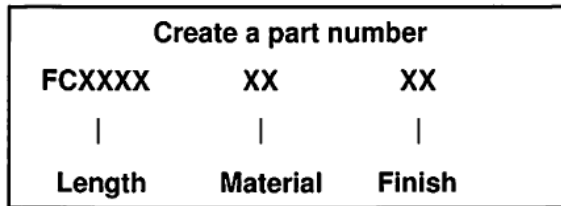

FCXXX	Length (L)	S.L. +/- .010
FC0830	5/16	3/32
FC0831	3/8	5/32
FC0832	7/16	7/32
FC0833	1/2	9/32
FC0834	9/16	11/32
FC0835	5/8	13/32
FC0836	11/16	15/32
FC0837	3/4	17/32
FC0838	13/16	19/32
FC0839	7/8	21/32
FC0840	15/16	23/32
FC0841	1	25/32

Material	
Material Code (XX)	
B	Brass
S	Steel
SS	Stainless Steel

See page 3 for finish codes



Fascomp Electronic Hardware
 7814 Kingspointe Pkwy
 Orlando, FL 32819
 www.fascomp.com
 Tel: (407) 226-2112
 Fax: (407)



Get quote >>

Captive Screw Type 4 8-32 Thread

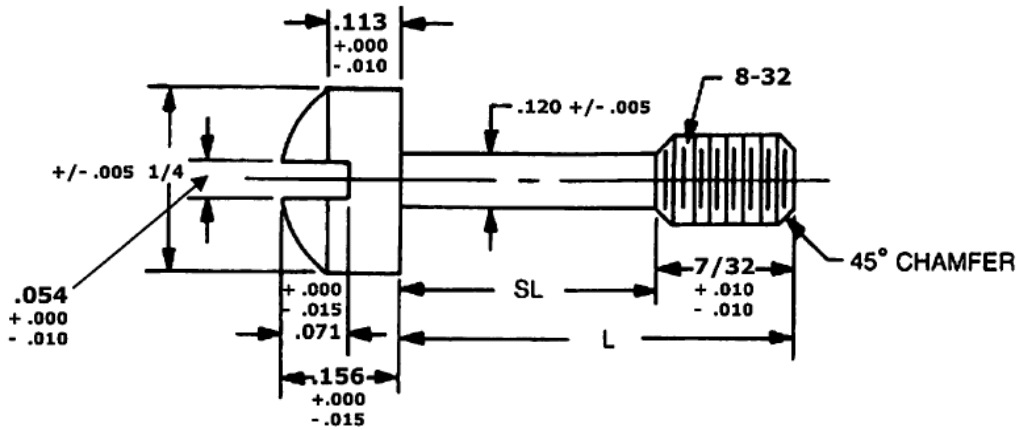

- Contact Sales Office for sizes not shown
- Source Control Drawing: To be produced by Fascomp Electronic Hardware

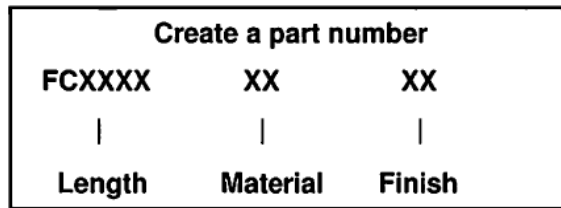

FCXXX	Length (L)	S.L. +/- .010
FC0842	5/16	3/32
FC0843	3/8	5/32
FC0844	7/16	7/32
FC0845	1/2	9/32
FC0846	9/16	11/32
FC0847	5/8	13/32
FC0848	11/16	15/32
FC0849	3/4	17/32
FC0850	13/16	19/32
FC0851	7/8	21/32
FC0852	15/16	23/32
FC0853	1	25/32
FC0854	1-1/16	27/32
FC0855	1-1/8	29/32
FC0856	1-3/16	31/32
FC0857	1-1/4	1-1/32

Material	
Material Code (XX)	
B	Brass
S	Steel
SS	Stainless Steel

See page 3 for finish codes



Fascomp Electronic Hardware
 7814 Kingspointe Pkwy
 Orlando, FL 32819
 www.fascomp.com
 Tel: (407) 22
 Fax: (407) 22

Angic Global Solutions 1-888-872-0690
<https://www.AngicGlobal.com> Sales@AngicGlobal.com



Captive Screw Type 4 10-24 Thread

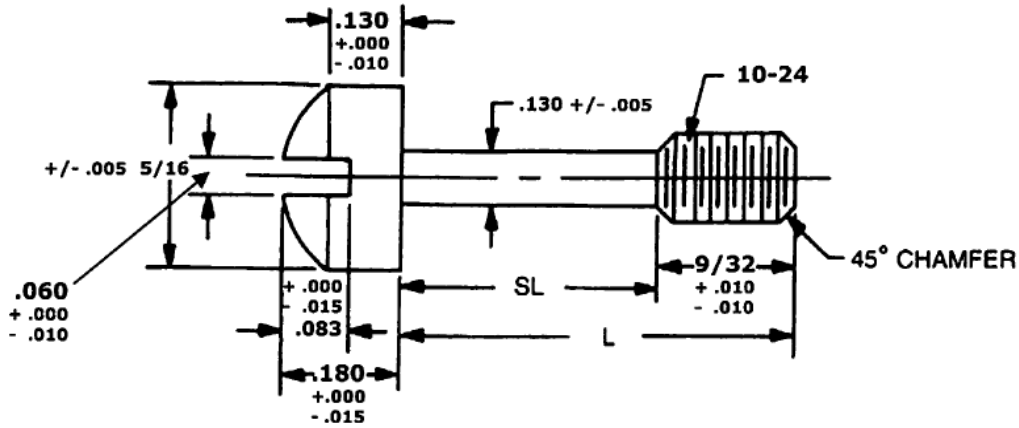

- Contact Sales Office for sizes not shown
- Source Control Drawing: To be produced by Fascomp Electronic Hardware

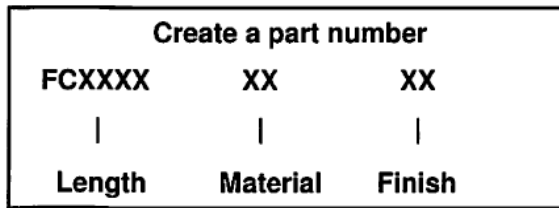

FCXXXX	Length (L)	S.L. +/- .010
FC0858	3/8	3/32
FC0859	7/16	5/32
FC0860	1/2	7/32
FC0861	9/16	9/32
FC0862	5/8	11/32
FC0863	11/16	13/32
FC0864	3/4	15/32
FC0865	13/16	17/32
FC0866	7/8	19/32
FC0867	15/16	21/32
FC0868	1	23/32
FC0869	1-1/16	25/32
FC0870	1-1/8	27/32
FC0871	1-3/16	29/32
FC0872	1-1/4	31/32
FC0873	1-5/16	1-1/32
FC0874	1-3/8	1-3/32
FC0875	1-7/16	1-5/32
FC0876	1-1/2	1-7/32

Material	
Material Code (XX)	
B	Brass
S	Steel
SS	Stainless Steel

See page 3 for finish codes



Fascomp Electronic Hardware
 7814 Kingspointe Pkwy
 Orlando, FL 32819
 www.fascomp.com
 Tel: (407) 2
 Fax: (407) 2



Get quote >>

Angic Global Solutions

1-888-872-0690 5

<https://www.AngicGlobal.com> Sales@AngicGlobal.com

Captive Screw Type 4 10-32 Thread

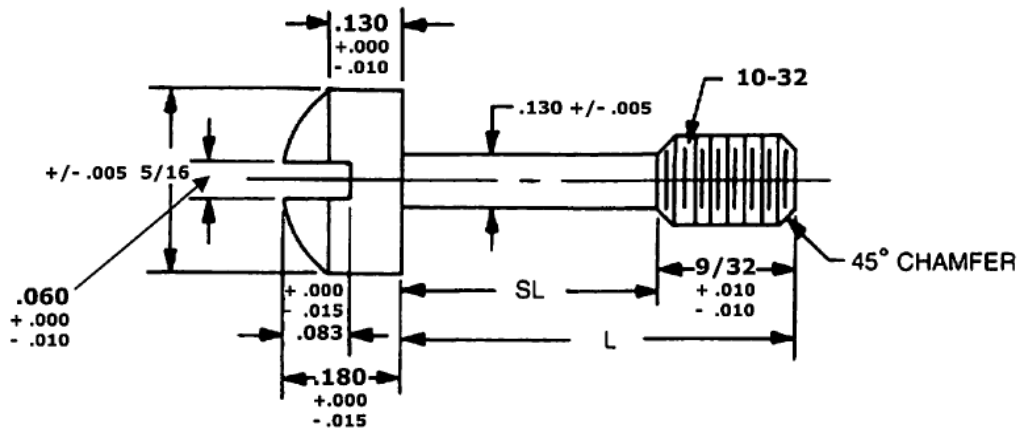

- Contact Sales Office for sizes not shown
- Source Control Drawing: To be produced by Fascomp Electronic Hardware

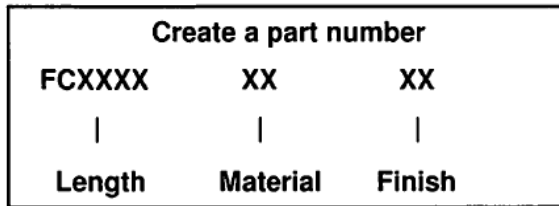

FCXXX	Length (L)	S.L. +/- .010
FC0877	3/8	3/32
FC0878	7/16	5/32
FC0879	1/2	7/32
FC0880	9/16	9/32
FC0881	5/8	11/32
FC0882	11/16	13/32
FC0883	3/4	15/32
FC0884	13/16	17/32
FC0885	7/8	19/32
FC0886	15/16	21/32
FC0887	1	23/32
FC0888	1-1/16	25/32
FC0889	1-1/8	27/32
FC0890	1-3/16	29/32
FC0891	1-1/4	31/32
FC0892	1-5/16	1-1/32
FC0893	1-3/8	1-3/32
FC0894	1-7/16	1-5/32
FC0895	1-1/2	1-7/32

Material	
Material Code (XX)	
B	Brass
S	Steel
SS	Stainless Steel

See page 3 for finish codes



Fascomp Electronic Hardware
 7814 Kingspointe Pkwy
 Orlando, FL 32819
 www.fascomp.com
 Tel: (407) 22
 Fax: (407) 22



Get quote >>



Captive Screws Type 5



Fascomp stocks type 5 Captive Screws in aluminum, brass, steel, and stainless steel.

	Page No.
4-40 Thread	48
6-32 Thread	49
8-32 Thread	50
10-24 Thread	51
10-32 Thread	52
Type 5 Washers	53



Fascomp Electronic Hardware
7814 Kingspointe Pkwy
Orlando, FL 32819
www.fascomp.com
(407) 226-2112



Get quote >>

Angic Global Solutions

1-888-872-0690

<https://www.AngicGlobal.com> Sales@AngicGlobal.com

Captive Screw Type 5 4-40 Thread

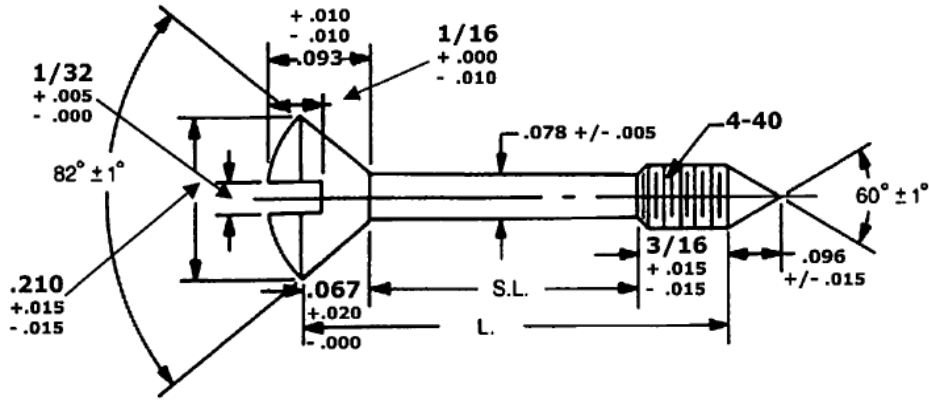

- Contact Sales Office for sizes not shown
- Source Control Drawing: To be produced by Fascomp Electronic Hardware

FCXXX	Length (L)	S.L. REF
FC0896	5/16	1/16
FC0897	3/8	1/8
FC0898	7/16	3/16
FC0899	1/2	1/4
FC0900	9/16	5/16
FC0901	5/8	3/8
FC0902	11/16	7/16
FC0903	3/4	1/2
FC0904	13/16	9/16
FC0905	7/8	5/8
FC0906	15/16	11/16
FC0907	1	3/4

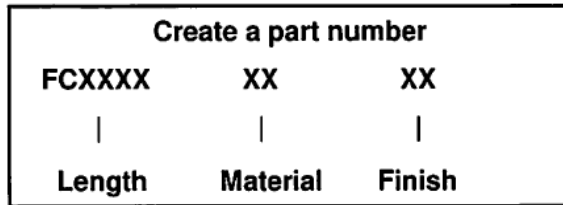

Material	
Material Code (XX)	
B	Brass
S	Steel
SS	Stainless Steel

See page 3 for finish codes



Fascomp Electronic Hardware
 7814 Kingspointe Pkwy
 Orlando, FL 32819
 www.fascomp.com
 Tel: (407) 222-2112
 Fax: (407) 222-2113



Captive Screw Type 5 6-32 Thread

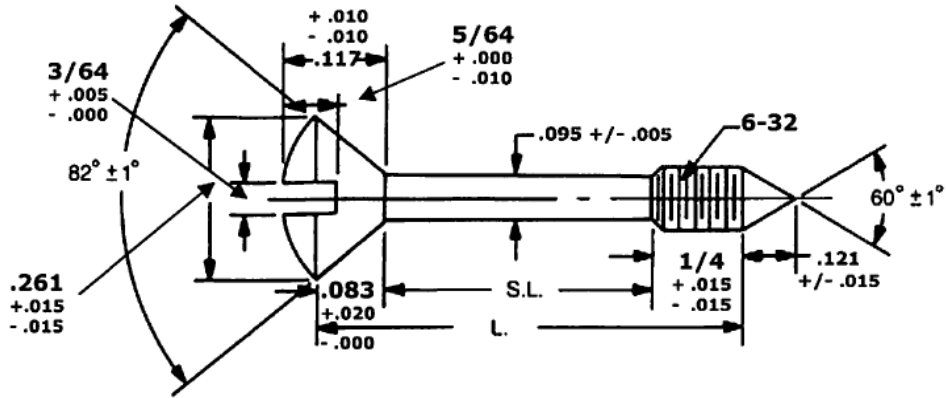

- Contact Sales Office for sizes not shown
- Source Control Drawing: To be produced by Fascomp Electronic Hardware

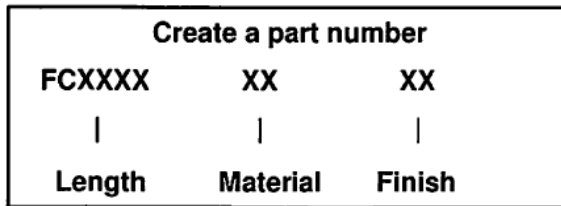

FCXXX	Length (L)	S.L. REF
FC0908	7/16	3/32
FC0909	1/2	5/32
FC0910	9/16	7/32
FC0911	5/8	9/32
FC0912	11/16	11/32
FC0913	3/4	13/32
FC0914	13/16	15/32
FC0915	7/8	17/32
FC0916	15/16	19/32
FC0917	1	21/32
FC0918	1-1/16	23/32
FC0919	1-1/8	25/32
FC0920	1-3/16	27/32
FC0921	1-1/4	29/32
FC0922	1-5/16	31/32
FC0923	1-3/8	1-1/32
FC0924	1-7/16	1-3/32
FC0925	1-1/2	1-5/32

Material	
Material Code (XX)	
B	Brass
S	Steel
SS	Stainless Steel

See page 3 for finish codes



Fascomp Electronic Hardware
 7814 Kingspointe Pkwy
 Orlando, FL 32819
 www.fascomp.com
 Tel: (407) 228-8888
 Fax: (407) 228-8888



Get quote >>

Angic Global Solutions

1-888-872-0690

<https://www.AngicGlobal.com> Sales@AngicGlobal.com

Captive Screw Type 5 8-32 Thread

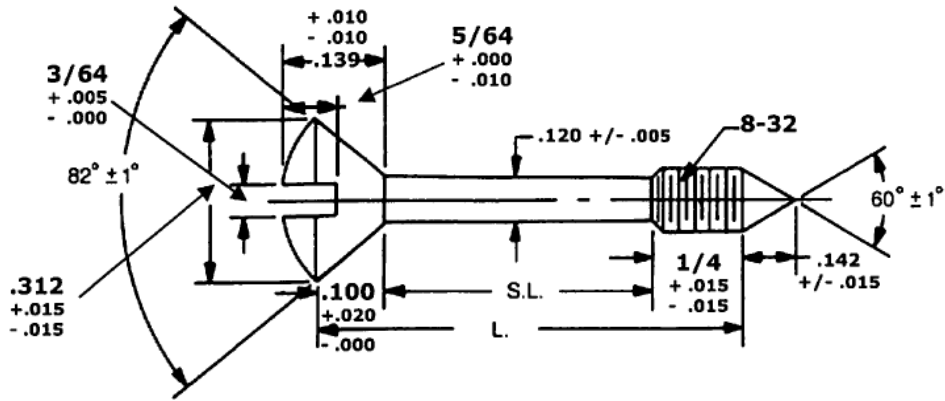

- Contact Sales Office for sizes not shown
- Source Control Drawing: To be produced by Fascomp Electronic Hardware

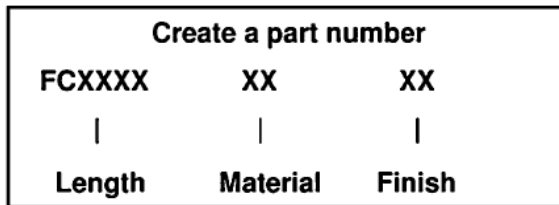

FCXXXX	Length (L)	S.L. REF
FC0926	1/2	9/64
FC0927	9/16	13/64
FC0928	5/8	17/64
FC0929	11/16	21/64
FC0930	3/4	25/64
FC0931	13/16	29/64
FC0932	7/8	33/64
FC0933	15/16	37/64
FC0934	1	41/64
FC0935	1-1/16	45/64
FC0936	1-1/8	49/64
FC0937	1-3/16	53/64
FC0938	1-1/4	57/64
FC0939	1-5/16	61/64
FC0940	1-3/8	1-1/64
FC0941	1-7/16	1-5/64
FC0942	1-1/2	1-9/64

Material	
Material Code (XX)	
B	Brass
S	Steel
SS	Stainless Steel

See page 3 for finish codes



Fascomp Electronic Hardware
 7814 Kingspointe Pkwy
 Orlando, FL 32819
 www.fascomp.com
 Tel: (407) 222-0112
 Fax: (407) 222-0112



Get quote >>

Captive Screw Type 5 10-24 Thread

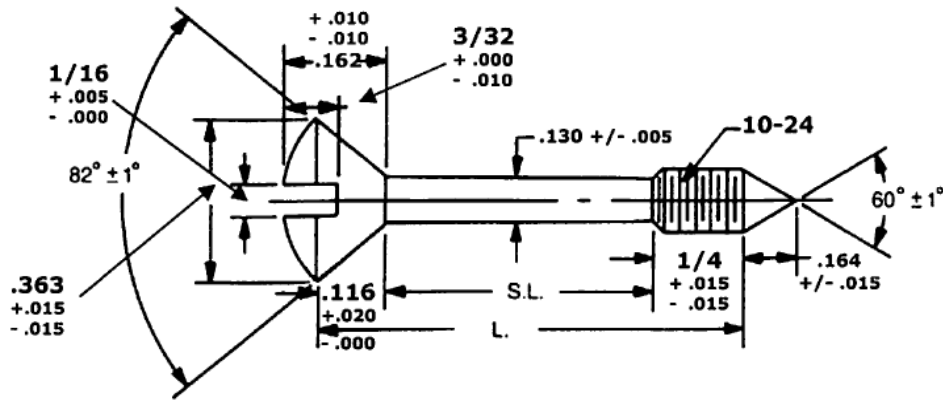

- Contact Sales Office for sizes not shown
- Source Control Drawing: To be produced by Fascomp Electronic Hardware

FCXXX	Length (L)	S.L. REF
FC0943	1/2	1.8
FC0944	9/16	3/16
FC0945	5/8	1/4
FC0946	11/16	5/16
FC0947	3/4	3/8
FC0948	13/16	7/16
FC0949	7/8	1/2
FC0950	15/16	9/16
FC0951	1	5/8
FC0952	1-1/16	11/16
FC0953	1-1/8	3/4
FC0954	1-3/16	13/16
FC0955	1-1/4	7/8
FC0956	1-5/16	15/16
FC0957	1-3/8	1
FC0958	1-7/16	1-1/16
FC0959	1-1/2	1-1/8
FC0960	1-9/16	1-3/16
FC0961	1-5/8	1-1/4
FC0962	1-11/16	1-5/16
FC0963	1-3/4	1-3/8
FC0964	1-13/16	1-7/16
FC0965	1-7/8	1-1/2
FC0966	1-15/16	1-9/16
FC0967	2	1-5/8

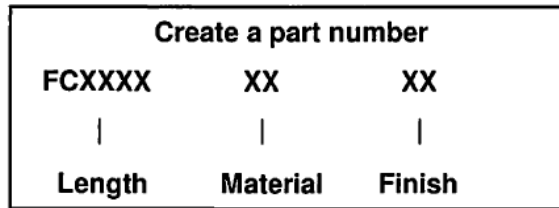

Material	
Material Code (XX)	
B	Brass
S	Steel
SS	Stainless Steel

See page 3 for finish codes



Fascomp Electronic Hardware
 7814 Kingspointe Pkwy
 Orlando, FL 32819
 www.fascomp.com
 Tel: (407) 2
 Fax: (407) 2

Angic Global Solutions

1-888-872-0690 1

<https://www.AngicGlobal.com> Sales@AngicGlobal.com



Get quote >>

Captive Screw Type 5 10-32 Thread

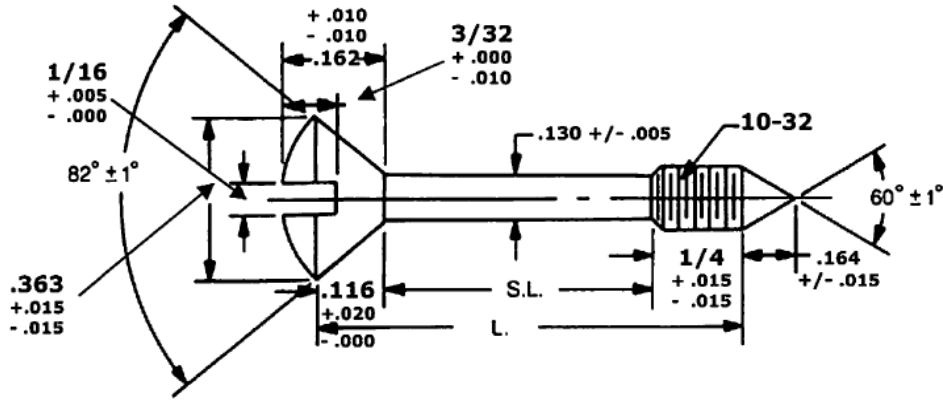

- Contact Sales Office for sizes not shown
- Source Control Drawing: To be produced by Fascomp Electronic Hardware

FCXXXX	Length (L)	S.L. REF
FC0968	1/2	1/8
FC0969	9/16	3/16
FC0970	5/8	1/4
FC0971	11/16	5/16
FC0972	3/4	3/8
FC0973	13/16	7/16
FC0974	7/8	1/2
FC0975	15/16	9/16
FC0976	1	5/8
FC0977	1-1/16	11/16
FC0978	1-1/8	3/4
FC0979	1-3/16	13/16
FC0980	1-1/4	7/8
FC0981	1-5/16	15/16
FC0982	1-3/8	1
FC0983	1-7/16	1-1/16
FC0984	1-1/2	1-1/8
FC0985	1-9/16	1-3/16
FC0986	1-5/8	1-1/4
FC0987	1-11/16	1-5/16
FC0988	1-3/4	1-3/8
FC0989	1-13/16	1-7/16
FC0990	1-7/8	1-1/2
FC0991	1-15/16	1-9/16
FC0992	2	1-5/8

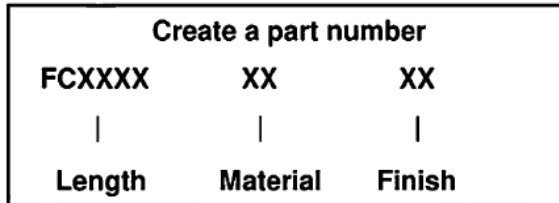

Material	
Material Code (XX)	
B	Brass
S	Steel
SS	Stainless Steel

See page 3 for finish codes



Fascomp Electronic Hardware
 7814 Kingspointe Pkwy
 Orlando, FL 32819
 www.fascomp.com
 Tel: (407) 226-2112
 Fax: (407) 226-2112



Captive Screw Type 5 Washers

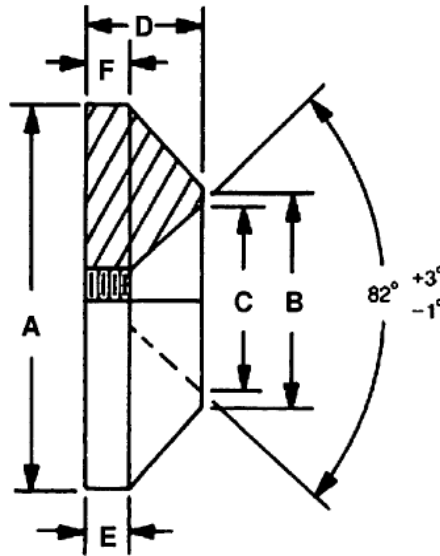

Create a part number		
FCXXXX	XX	XX
Length	Material	Finish

FCXXXX	Thread	A	B	C	D	E	F
		+ .005 - .005	+ .005 - .005	+ .005 - .005	+ .000 - .010	+ .005 - .005	+ .012 - .012
FC0993	4-40	3/8	.265	.234	.156	1/64	.062
FC0994	6-32	7/16	.328	.296	.171	1/32	.078
FC0995	8-32	9/16	.375	.343	.203	1/32	.078
FC0996	10-24	5/8	.421	.390	.218	1/32	.078
FC0997	10-32	5/8	.421	.390	.218	1/32	.078

Material	
Material Code (XX)	
B	Brass
S	Steel
SS	Stainless Steel

See page 3 for finish codes

- Contact Sales Office for sizes not shown
- Source Control Drawing: To be produced by Fascomp Electronic Hardware



Fascomp Electronic Hardware
7814 Kingspointe Pkwy
Orlando, FL 32819
www.fascomp.com
Tel: (407) 226-2111
Fax: (407) 226-3333



Get quote >>

Angic Global Solutions

1-888-872-0690 3

<https://www.AngicGlobal.com> Sales@AngicGlobal.com



Retainers



Fascomp stocks Type A, Type B, Type C, Type D, Type E, Type F and Type G Retainers in brass, steel, and stainless steel.

	Page No.
Type A	55
Type B	56
Type C	57
Type D	58
Type E	59
Type F	60
Type G	61



Fascomp Electronic Hardware
7814 Kingspointe Pkwy
Orlando, FL 32819
www.fascomp.com
Tel: (407) 226-2112



Retainers—Type A

- Contact Sales Office for sizes not shown
- Source Control Drawing: To be produced by Fascomp Electronic Hardware

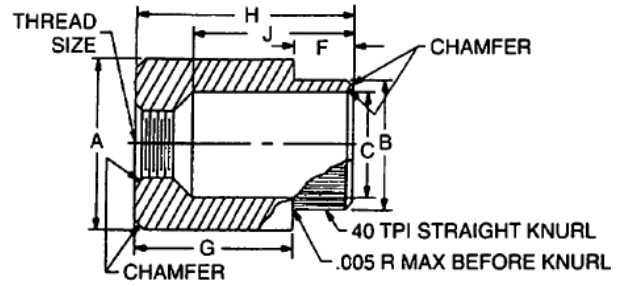

FCXXX-XXX	Thread	Panel Thickness	A +.004 -.004	B +.000 -.003	C +.004 -.001	F +.005 -.005	G +.005 -.005	H +.010 -.010	J +.005 -.005
FC1000-050	4-40	.048 - .072	1/4	.198	.150	.050	.200	1/4	.164
FC1000-080	4-40	.074 - .109	1/4	.198	.150	.080	.170	1/4	.164
FC1000-125	4-40	.119 - .156	1/4	.198	.150	.125	.125	1/4	.164
FC1001-050	6-32	.048 - .072	1/4	.198	.150	.050	.262	5/16	.210
FC1001-080	6-32	.074 - .109	1/4	.198	.150	.080	.232	5/16	.210
FC1001-125	6-32	.119 - .156	1/4	.198	.150	.125	.187	5/16	.210
FC1001-188	6-32	.188 -	1/4	.198	.150	.188	.124	5/16	.210
FC1002-050	8-32	.048 - .072	5/16	.228	.188	.050	.262	5/16	.208
FC1002-080	8-32	.074 - .109	5/16	.228	.188	.080	.232	5/16	.208
FC1002-125	8-32	.119 - .156	5/16	.228	.188	.125	.187	5/16	.208
FC1002-188	8-32	.188 -	5/16	.228	.188	.188	.124	5/16	.208
FC1003-050	10-24	.048 - .072	3/8	.280	.228	.050	.325	3/8	.236
FC1003-080	10-24	.074 - .109	3/8	.280	.228	.080	.295	3/8	.236
FC1003-125	10-24	.119 - .156	3/8	.280	.228	.125	.250	3/8	.236
FC1003-188	10-24	.188 -	3/8	.280	.228	.188	.187	3/8	.236
FC1003-250	10-24	.250 -	3/8	.280	.228	.250	.125	3/8	.236
FC1004-050	10-32	.048 - .072	3/8	.280	.228	.050	.325	3/8	.236
FC1004-080	10-32	.074 - .109	3/8	.280	.228	.080	.295	3/8	.236
FC1004-125	10-32	.119 - .156	3/8	.280	.228	.125	.250	3/8	.236
FC1004-188	10-32	.188 -	3/8	.280	.228	.188	.187	3/8	.236
FC1004-250	10-32	.250 -	3/8	.280	.228	.250	.125	3/8	.236
FC1005-050	1/4-20	.048 - .072	1/2	.366	.295	.050	.387	7/16	.292
FC1005-080	1/4-20	.074 - .109	1/2	.366	.295	.080	.357	7/16	.292
FC1005-125	1/4-20	.119 - .156	1/2	.366	.295	.125	.312	7/16	.292
FC1005-188	1/4-20	.188 -	1/2	.366	.295	.188	.249	7/16	.292
FC1005-250	1/4-20	.250 -	1/2	.366	.295	.250	.187	7/16	.292
FC1006-050	1/4-28	.048 - .072	1/2	.366	.295	.050	.387	7/16	.292
FC1006-080	1/4-28	.074 - .109	1/2	.366	.295	.080	.357	7/16	.292
FC1006-125	1/4-28	.119 - .156	1/2	.366	.295	.125	.312	7/16	.292
FC1006-188	1/4-28	.188 -	1/2	.366	.295	.188	.249	7/16	.292
FC1006-250	1/4-28	.250 -	1/2	.366	.295	.250	.187	7/16	.292
FC1007-050	5/16-18	.048 - .072	5/8	.414	.347	.050	.450	1/2	.358
FC1007-080	5/16-18	.074 - .109	5/8	.414	.347	.080	.420	1/2	.358
FC1007-125	5/16-18	.119 - .156	5/8	.414	.347	.125	.375	1/2	.358
FC1007-188	5/16-18	.188 -	5/8	.414	.347	.188	.312	1/2	.358
FC1007-250	5/16-18	.250 -	5/8	.414	.347	.250	.250	1/2	.358
FC1008-080	3/8-16	.074 - .109	3/4	.479	.406	.080	.482	9/16	.418
FC1008-125	3/8-16	.119 - .156	3/4	.479	.406	.125	.437	9/16	.418
FC1008-188	3/8-16	.188 -	3/4	.479	.406	.188	.374	9/16	.418
FC1008-250	3/8-16	.250 -	3/4	.479	.406	.250	.312	9/16	.418

Create a part number

FCXXX-XXX	XX	XX
Length	Material	Finish

Material	
Material Code (XX)	
B	Brass
S	Steel
SS	Stainless Steel

See page 3 for finish codes



Fascomp Electronic Hardware
7814 Kingspointe Pkwy
Orlando, FL 32819
www.fascomp.com



Get quote >>

Angic Global Solutions

1-888-872-0690

<https://www.AngicGlobal.com> Sales@AngicGlobal.com

Retainers—Type B

- Contact Sales Office for sizes not shown
- Source Control Drawing: To be produced by Fascomp Electronic Hardware

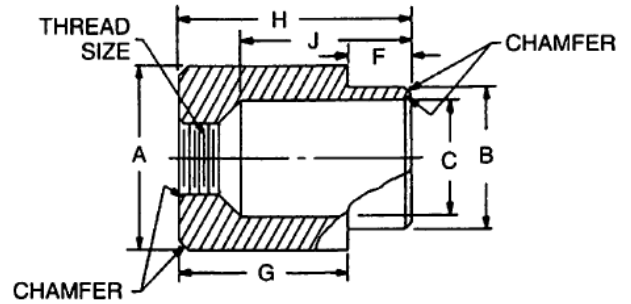

FCXXX -XXX	Thread	Panel Thickness	A +.004 -.004	B +.000 -.003	C +.004 -.001	F +.005 -.005	G +.005 -.005	H +.010 -.010	J +.005 -.005
FC1009-062	4-40	.052 - .067	9/32	.250	.210	.062	.312	3/8	.263
FC1009-093	4-40	.084 - .099	9/32	.250	.210	.093	.281	3/8	.263
FC1009-125	4-40	.109 - .140	9/32	.250	.210	.125	.250	3/8	.263
FC1009-187	4-40	.171 - .203	9/32	.250	.210	.187	.187	3/8	.263
FC1010-062	6-32	.052 - .067	9/32	.250	.210	.062	.312	3/8	.265
FC1010-093	6-32	.084 - .099	9/32	.250	.210	.093	.281	3/8	.265
FC1010-125	6-32	.109 - .140	9/32	.250	.210	.125	.250	3/8	.265
FC1010-187	6-32	.171 - .203	9/32	.250	.210	.187	.187	3/8	.265
FC1010-250	6-32	.234 - .265	9/32	.250	.210	.250	.125	3/8	.265
FC1011-062	8-32	.052 - .067	17/32	.433	.386	.062	.500	9/16	.388
FC1011-093	8-32	.084 - .099	17/32	.433	.386	.093	.468	9/16	.388
FC1011-125	8-32	.109 - .140	17/32	.433	.386	.125	.437	9/16	.388
FC1011-187	8-32	.171 - .203	17/32	.433	.386	.187	.375	9/16	.388
FC1011-250	8-32	.234 - .265	17/32	.433	.386	.250	.312	9/16	.388
FC1012-062	10-24	.052 - .067	17/32	.433	.386	.062	.500	9/16	.395
FC1012-093	10-24	.084 - .099	17/32	.433	.386	.093	.468	9/16	.395
FC1012-125	10-24	.109 - .140	17/32	.433	.386	.125	.437	9/16	.395
FC1012-187	10-24	.171 - .203	17/32	.433	.386	.187	.375	9/16	.395
FC1012-250	10-24	.234 - .265	17/32	.433	.386	.250	.312	9/16	.395
FC1013-062	10-32	.052 - .067	17/32	.433	.386	.062	.500	9/16	.395
FC1013-093	10-32	.084 - .099	17/32	.433	.386	.093	.468	9/16	.395
FC1013-125	10-32	.109 - .140	17/32	.433	.386	.125	.437	9/16	.395
FC1013-187	10-32	.171 - .203	17/32	.433	.386	.187	.375	9/16	.395
FC1013-250	10-32	.234 - .265	17/32	.433	.386	.250	.312	9/16	.395
FC1014-062	12-24	.052 - .067	17/32	.433	.386	.062	.500	9/16	.396
FC1014-093	12-24	.084 - .099	17/32	.433	.386	.093	.468	9/16	.396
FC1014-125	12-24	.109 - .140	17/32	.433	.386	.125	.437	9/16	.396
FC1014-187	12-24	.171 - .203	17/32	.433	.386	.187	.375	9/16	.396
FC1014-250	12-24	.234 - .265	17/32	.433	.386	.250	.312	9/16	.396
FC1015-062	1/4-20	.052 - .067	17/32	.433	.386	.062	.500	9/16	.403
FC1015-093	1/4-20	.084 - .099	17/32	.433	.386	.093	.468	9/16	.403
FC1015-125	1/4-20	.109 - .140	17/32	.433	.386	.125	.437	9/16	.403
FC1015-187	1/4-20	.171 - .203	17/32	.433	.386	.187	.375	9/16	.403
FC1015-250	1/4-20	.234 - .265	17/32	.433	.386	.250	.312	9/16	.403
FC1016-062	1/4-28	.052 - .067	17/32	.433	.386	.062	.500	9/16	.403
FC1016-093	1/4-28	.084 - .099	17/32	.433	.386	.093	.468	9/16	.403
FC1016-125	1/4-28	.109 - .140	17/32	.433	.386	.125	.437	9/16	.403
FC1016-187	1/4-28	.171 - .203	17/32	.433	.386	.187	.375	9/16	.403
FC1016-250	1/4-28	.234 - .265	17/32	.433	.386	.250	.312	9/16	.403

Create a part number

FCXXX-XXX	XX	XX
Length	Material	Finish

Material	
Material Code (XX)	
B	Brass
S	Steel
SS	Stainless Steel

See page 3 for finish codes



Fascomp Electronic Hardware
7814 Kingspointe Pkwy
Orlando, FL 32819
www.fascomp.com



Retainers—Type C

- Contact Sales Office for sizes not shown
- Source Control Drawing: To be produced by Fascomp Electronic Hardware

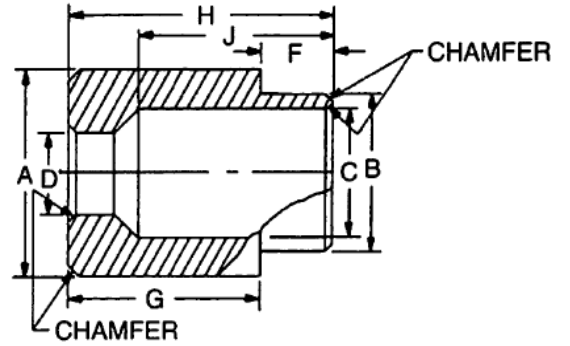

FCXXX -XXX	Thread	Panel Thickness	A +.004 -.004	B +.000 -.003	C +.004 -.001	D +.004 -.001	F +.005 -.005	G +.005 -.005	H +.010 -.010	J +.005 -.005
FC1017-062	4-40	.052 - .067	9/32	.250	.210	.125	.062	.312	3/8	.299
FC1017-093	4-40	.084 - .099	9/32	.250	.210	.125	.093	.281	3/8	.299
FC1017-125	4-40	.109 - .140	9/32	.250	.210	.125	.125	.250	3/8	.299
FC1017-187	4-40	.171 - .203	9/32	.250	.210	.125	.187	.187	3/8	.299
FC1018-062	6-32	.052 - .067	9/32	.250	.210	.152	.062	.312	3/8	.304
FC1018-093	6-32	.084 - .099	9/32	.250	.210	.152	.093	.281	3/8	.304
FC1018-125	6-32	.109 - .140	9/32	.250	.210	.152	.125	.250	3/8	.304
FC1018-187	6-32	.171 - .203	9/32	.250	.210	.152	.187	.187	3/8	.304
FC1019-062	8-32	.052 - .067	17/32	.433	.386	.177	.062	.500	9/16	.447
FC1019-093	8-32	.084 - .099	17/32	.433	.386	.177	.093	.468	9/16	.447
FC1019-125	8-32	.109 - .140	17/32	.433	.386	.177	.125	.437	9/16	.447
FC1019-187	8-32	.171 - .203	17/32	.433	.386	.177	.187	.375	9/16	.447
FC1019-250	8-32	.234 - .265	17/32	.433	.386	.177	.250	.312	9/16	.447
FC1020-062	10-24	.052 - .067	17/32	.433	.386	.203	.062	.500	9/16	.464
FC1020-093	10-24	.084 - .099	17/32	.433	.386	.203	.093	.468	9/16	.464
FC1020-125	10-24	.109 - .140	17/32	.433	.386	.203	.125	.437	9/16	.464
FC1020-187	10-24	.171 - .203	17/32	.433	.386	.203	.187	.375	9/16	.464
FC1020-250	10-24	.234 - .265	17/32	.433	.386	.203	.250	.312	9/16	.464
FC1021-062	10-32	.052 - .067	17/32	.433	.386	.203	.062	.500	9/16	.464
FC1021-093	10-32	.084 - .099	17/32	.433	.386	.203	.093	.468	9/16	.464
FC1021-125	10-32	.109 - .140	17/32	.433	.386	.203	.125	.437	9/16	.464
FC1021-187	10-32	.171 - .203	17/32	.433	.386	.203	.187	.375	9/16	.464
FC1021-250	10-32	.234 - .265	17/32	.433	.386	.203	.250	.312	9/16	.464
FC1022-062	12-24	.052 - .067	17/32	.433	.386	.228	.062	.500	9/16	.459
FC1022-093	12-24	.084 - .099	17/32	.433	.386	.228	.093	.468	9/16	.459
FC1022-125	12-24	.109 - .140	17/32	.433	.386	.228	.125	.437	9/16	.459
FC1022-187	12-24	.171 - .203	17/32	.433	.386	.228	.187	.375	9/16	.459
FC1022-250	12-24	.234 - .265	17/32	.433	.386	.228	.250	.312	9/16	.459
FC1023-062	1/4-20	.052 - .067	17/32	.433	.386	.257	.062	.500	9/16	.475
FC1023-093	1/4-20	.084 - .099	17/32	.433	.386	.257	.093	.468	9/16	.475
FC1023-125	1/4-20	.109 - .140	17/32	.433	.386	.257	.125	.437	9/16	.475
FC1023-187	1/4-20	.171 - .203	17/32	.433	.386	.257	.187	.375	9/16	.475
FC1023-250	1/4-20	.234 - .265	17/32	.433	.386	.257	.250	.312	9/16	.475
FC1024-062	1/4-28	.052 - .067	17/32	.433	.386	.257	.062	.500	9/16	.475
FC1024-093	1/4-28	.084 - .099	17/32	.433	.386	.257	.093	.468	9/16	.475
FC1024-125	1/4-28	.109 - .140	17/32	.433	.386	.257	.125	.437	9/16	.475
FC1024-187	1/4-28	.171 - .203	17/32	.433	.386	.257	.187	.375	9/16	.475
FC1024-250	1/4-28	.234 - .265	17/32	.433	.386	.257	.250	.312	9/16	.475

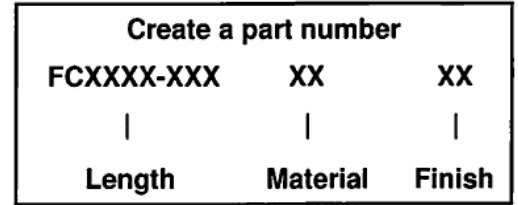

Material	
Material Code (XX)	
B	Brass
S	Steel
SS	Stainless Steel

See page 3 for finish codes



Fascomp Electronic Hardware
7814 Kingspointe Pkwy
Orlando, FL 32819
www.fascomp.com



Get quote >>

Angic Global Solutions

1-888-872-0690

<https://www.AngicGlobal.com> Sales@AngicGlobal.com

Retainers—Type D

- Contact Sales Office for sizes not shown
- Source Control Drawing: To be produced by Fascomp Electronic Hardware

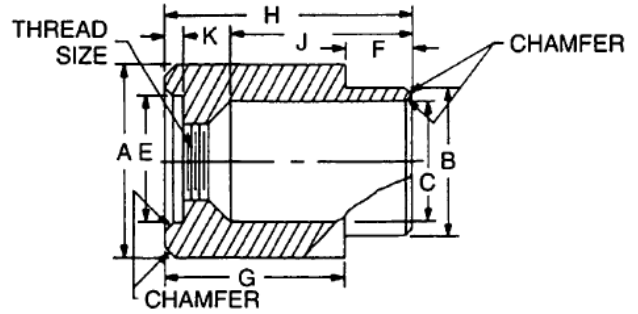

FCXXX-XXX	Thd	Panel Thickness	A +.004 -.004	B +.000 -.003	C +.004 -.001	E +.005 -.000	F +.005 -.005	G +.005 -.005	H +.010 -.010	J +.005 -.005	K +.010 -.000
FC1025-062	4-40	.052 - .067	9/32	.250	.210	.192	.062	.375	7/16	.263	.078
FC1025-093	4-40	.084 - .099	9/32	.250	.210	.192	.093	.344	7/16	.263	.078
FC1025-125	4-40	.109 - .140	9/32	.250	.210	.192	.125	.312	7/16	.263	.078
FC1025-187	4-40	.171 - .203	9/32	.250	.210	.192	.187	.250	7/16	.263	.078
FC1025-250	4-40	.234 - .265	9/32	.250	.210	.192	.250	.187	7/16	.263	.078
FC1026-062	6-32	.052 - .067	9/32	.250	.210	.192	.062	.375	7/16	.266	.078
FC1026-093	6-32	.084 - .099	9/32	.250	.210	.192	.093	.344	7/16	.266	.078
FC1026-125	6-32	.109 - .140	9/32	.250	.210	.192	.125	.312	7/16	.266	.078
FC1026-187	6-32	.171 - .203	9/32	.250	.210	.192	.187	.250	7/16	.266	.078
FC1026-250	6-32	.234 - .265	9/32	.250	.210	.192	.250	.187	7/16	.266	.078
FC1027-062	8-32	.052 - .067	17/32	.433	.386	.312	.062	.562	5/8	.388	.093
FC1027-093	8-32	.084 - .099	17/32	.433	.386	.312	.093	.532	5/8	.388	.093
FC1027-125	8-32	.109 - .140	17/32	.433	.386	.312	.125	.500	5/8	.388	.093
FC1027-187	8-32	.171 - .203	17/32	.433	.386	.312	.187	.437	5/8	.388	.093
FC1027-250	8-32	.234 - .265	17/32	.433	.386	.312	.250	.375	5/8	.388	.093
FC1028-062	10-24	.052 - .067	17/32	.433	.386	.312	.062	.562	5/8	.393	.093
FC1028-093	10-24	.084 - .099	17/32	.433	.386	.312	.093	.532	5/8	.393	.093
FC1028-125	10-24	.109 - .140	17/32	.433	.386	.312	.125	.500	5/8	.393	.093
FC1028-187	10-24	.171 - .203	17/32	.433	.386	.312	.187	.437	5/8	.393	.093
FC1028-250	10-24	.234 - .265	17/32	.433	.386	.312	.250	.375	5/8	.393	.093
FC1029-062	10-32	.052 - .067	17/32	.433	.386	.312	.062	.562	5/8	.393	.093
FC1029-093	10-32	.084 - .099	17/32	.433	.386	.312	.093	.532	5/8	.393	.093
FC1029-125	10-32	.109 - .140	17/32	.433	.386	.312	.125	.500	5/8	.393	.093
FC1029-187	10-32	.171 - .203	17/32	.433	.386	.312	.187	.437	5/8	.393	.093
FC1029-250	10-32	.234 - .265	17/32	.433	.386	.312	.250	.375	5/8	.393	.093
FC1030-062	12-24	.052 - .067	17/32	.433	.386	.312	.062	.562	5/8	.397	.093
FC1030-093	12-24	.084 - .099	17/32	.433	.386	.312	.093	.532	5/8	.397	.093
FC1030-125	12-24	.109 - .140	17/32	.433	.386	.312	.125	.500	5/8	.397	.093
FC1030-187	12-24	.171 - .203	17/32	.433	.386	.312	.187	.437	5/8	.397	.093
FC1030-250	12-24	.234 - .265	17/32	.433	.386	.312	.250	.375	5/8	.397	.093
FC1031-062	1/4-20	.052 - .067	17/32	.433	.386	.312	.062	.562	5/8	.405	.093
FC1031-093	1/4-20	.084 - .099	17/32	.433	.386	.312	.093	.532	5/8	.405	.093
FC1031-125	1/4-20	.109 - .140	17/32	.433	.386	.312	.125	.500	5/8	.405	.093
FC1031-187	1/4-20	.171 - .203	17/32	.433	.386	.312	.187	.437	5/8	.405	.093
FC1031-250	1/4-20	.234 - .265	17/32	.433	.386	.312	.250	.375	5/8	.405	.093
FC1032-062	1/4-28	.052 - .067	17/32	.433	.386	.312	.062	.562	5/8	.405	.093
FC1032-093	1/4-28	.084 - .099	17/32	.433	.386	.312	.093	.532	5/8	.405	.093
FC1032-125	1/4-28	.109 - .140	17/32	.433	.386	.312	.125	.500	5/8	.405	.093
FC1032-187	1/4-28	.171 - .203	17/32	.433	.386	.312	.187	.437	5/8	.405	.093
FC1032-250	1/4-28	.234 - .265	17/32	.433	.386	.312	.250	.375	5/8	.405	.093

Create a part number

FCXXX-XXX	XX	XX
Length	Material	Finish

Material	
Material Code (XX)	
B	Brass
S	Steel
SS	Stainless Steel

See page 3 for finish codes



Fascomp Electronic Hardware
 7814 Kingspointe Pkwy
 Orlando, FL 32819
 www.fascomp.com
 Tel: (407) 226-2112



Get quote >>

Retainers—Type E

Create a part number		
FCXXX-XXX	XX	XX
Length	Material	Finish

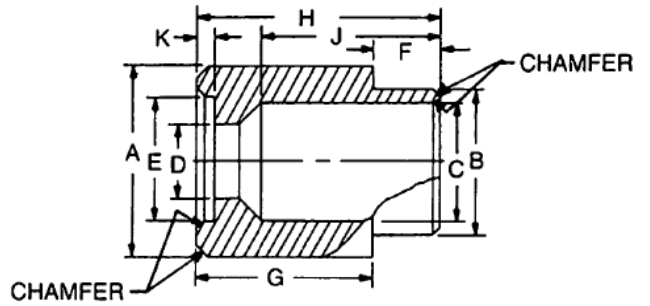

FCXXX-XXX	Thd	Panel Thickness	A +.004 -.004	B +.000 -.003	C +.004 -.001	D +.004 -.001	E +.005 -.000	F +.005 -.005	G +.005 -.005	H +.010 -.010	J +.005 -.005	K +.010 -.000
FC1033-062	4-40	.052 - .067	9/32	.250	.210	.125	.192	.062	.375	7/16	.299	.078
FC1033-093	4-40	.084 - .099	9/32	.250	.210	.125	.192	.093	.344	7/16	.299	.078
FC1033-125	4-40	.109 - .140	9/32	.250	.210	.125	.192	.125	.312	7/16	.299	.078
FC1033-187	4-40	.171 - .203	9/32	.250	.210	.125	.192	.187	.250	7/16	.299	.078
FC1033-250	4-40	.234 - .265	9/32	.250	.210	.125	.192	.250	.187	7/16	.299	.078
FC1034-062	6-32	.052 - .067	9/32	.250	.210	.150	.192	.062	.375	7/16	.305	.078
FC1034-093	6-32	.084 - .099	9/32	.250	.210	.150	.192	.093	.344	7/16	.305	.078
FC1034-125	6-32	.109 - .140	9/32	.250	.210	.150	.192	.125	.312	7/16	.305	.078
FC1034-187	6-32	.171 - .203	9/32	.250	.210	.150	.192	.187	.250	7/16	.305	.078
FC1034-250	6-32	.234 - .265	9/32	.250	.210	.150	.192	.250	.187	7/16	.305	.078
FC1035-062	8-32	.052 - .067	17/32	.433	.386	.175	.312	.062	.562	5/16	.427	.093
FC1035-093	8-32	.084 - .099	17/32	.433	.386	.175	.312	.093	.532	5/8	.427	.093
FC1035-125	8-32	.109 - .140	17/32	.433	.386	.175	.312	.125	.500	5/8	.427	.093
FC1035-187	8-32	.171 - .203	17/32	.433	.386	.175	.312	.187	.437	5/8	.427	.093
FC1035-250	8-32	.234 - .265	17/32	.433	.386	.175	.312	.250	.375	5/8	.427	.093
FC1036-062	10-24	.052 - .067	17/32	.433	.386	.203	.312	.062	.562	5/8	.432	.093
FC1036-093	10-24	.084 - .099	17/32	.433	.386	.203	.312	.093	.532	5/8	.432	.093
FC1036-125	10-24	.109 - .140	17/32	.433	.386	.203	.312	.125	.500	5/8	.432	.093
FC1036-187	10-24	.171 - .203	17/32	.433	.386	.203	.312	.187	.437	5/8	.432	.093
FC1036-250	10-24	.234 - .265	17/32	.433	.386	.203	.312	.250	.375	5/8	.432	.093
FC1037-062	10-32	.052 - .067	17/32	.433	.386	.203	.312	.062	.562	5/8	.432	.093
FC1037-093	10-32	.084 - .099	17/32	.433	.386	.203	.312	.093	.532	5/8	.432	.093
FC1037-125	10-32	.109 - .140	17/32	.433	.386	.203	.312	.125	.500	5/8	.432	.093
FC1037-187	10-32	.171 - .203	17/32	.433	.386	.203	.312	.187	.437	5/8	.432	.093
FC1037-250	10-32	.234 - .265	17/32	.433	.386	.203	.312	.250	.375	5/8	.432	.093
FC1038-062	12-24	.052 - .067	17/32	.433	.386	.228	.312	.062	.562	5/8	.438	.093
FC1038-093	12-24	.084 - .099	17/32	.433	.386	.228	.312	.093	.532	5/8	.438	.093
FC1038-125	12-24	.109 - .140	17/32	.433	.386	.228	.312	.125	.500	5/8	.438	.093
FC1038-187	12-24	.171 - .203	17/32	.433	.386	.228	.312	.187	.437	5/8	.438	.093
FC1038-250	12-24	.234 - .265	17/32	.433	.386	.228	.312	.250	.375	5/8	.438	.093
FC1039-062	1/4-20	.052 - .067	17/32	.433	.386	.257	.312	.062	.562	5/8	.445	.093
FC1039-093	1/4-20	.084 - .099	17/32	.433	.386	.257	.312	.093	.532	5/8	.445	.093
FC1039-125	1/4-20	.109 - .140	17/32	.433	.386	.257	.312	.125	.500	5/8	.445	.093
FC1039-187	1/4-20	.171 - .203	17/32	.433	.386	.257	.312	.187	.437	5/8	.445	.093
FC1039-250	1/4-20	.234 - .265	17/32	.433	.386	.257	.312	.250	.375	5/8	.445	.093
FC1040-062	1/4-28	.052 - .067	17/32	.433	.386	.257	.312	.062	.562	5/8	.445	.093
FC1040-093	1/4-28	.084 - .099	17/32	.433	.386	.257	.312	.093	.532	5/8	.445	.093
FC1040-125	1/4-28	.109 - .140	17/32	.433	.386	.257	.312	.125	.500	5/8	.445	.093
FC1040-187	1/4-28	.171 - .203	17/32	.433	.386	.257	.312	.187	.437	5/8	.445	.093
FC1040-250	1/4-28	.234 - .265	17/32	.433	.386	.257	.312	.250	.375	5/8	.445	.093

Material	
Material Code (XX)	
B	Brass
S	Steel
SS	Stainless Steel

See page 3 for finish codes

- Contact Sales Office for sizes not shown
- Source Control Drawing: To be produced by Fascomp Electronic Hardware



Fascomp Electronic Hardware
7814 Kingspointe Pkwy
Orlando, FL 32819
www.fascomp.com
Tel: (407) 226-2112



Get quote >>

Angic Global Solutions

1-888-872-0690

<https://www.AngicGlobal.com> Sales@AngicGlobal.com

Retainers—Type F

- Contact Sales Office for sizes not shown
- Source Control Drawing: To be produced by Fascomp Electronic Hardware

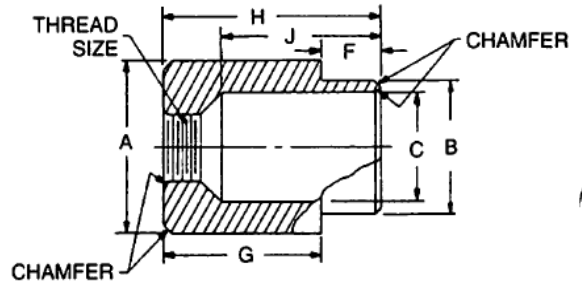

FCXXX -XXX	Thd	Panel Thickness	A	B	C	F	G	H	J
			+ .004 - .004	+ .002 - .002	+ .004 - .001	+ .005 - .005	+ .005 - .005	+ .010 - .010	+ .005 - .005
FC1041-062	4-40	.052 - .067	1/4	.188	.150	.062	.188	1/4	.161
FC1041-093	4-40	.084 - .099	1/4	.188	.150	.093	.156	1/4	.161
FC1041-125	4-40	.109 - .140	1/4	.188	.150	.125	.125	1/4	.161
FC1042-062	6-32	.052 - .067	1/4	.188	.150	.062	.250	5/16	.210
FC1042-093	6-32	.084 - .099	1/4	.188	.150	.093	.218	5/16	.210
FC1042-125	6-32	.109 - .140	1/4	.188	.150	.125	.187	5/16	.210
FC1042-187	6-32	.171 - .203	1/4	.188	.150	.187	.125	5/16	.210
FC1043-062	8-32	.052 - .067	3/8	.218	.188	.062	.250	5/16	.210
FC1043-093	8-32	.084 - .099	3/8	.218	.188	.093	.218	5/16	.210
FC1043-125	8-32	.109 - .140	3/8	.218	.188	.125	.187	5/16	.210
FC1043-187	8-32	.171 - .203	3/8	.218	.188	.187	.125	5/16	.210
FC1044-062	10-24	.052 - .067	3/8	.270	.228	.062	.312	3/8	.236
FC1044-093	10-24	.084 - .099	3/8	.270	.228	.093	.281	3/8	.236
FC1044-125	10-24	.109 - .140	3/8	.270	.228	.125	.250	3/8	.236
FC1044-187	10-24	.171 - .203	3/8	.270	.228	.187	.188	3/8	.236
FC1044-250	10-24	.234 - .265	3/8	.270	.228	.250	.125	3/8	.236
FC1045-062	10-32	.052 - .067	3/8	.270	.228	.062	.312	3/8	.236
FC1045-093	10-32	.084 - .099	3/8	.270	.228	.093	.281	3/8	.236
FC1045-125	10-32	.109 - .140	3/8	.270	.228	.125	.250	3/8	.236
FC1045-187	10-32	.171 - .203	3/8	.270	.228	.187	.188	3/8	.236
FC1045-250	10-32	.234 - .265	3/8	.270	.228	.250	.125	3/8	.236
FC1046-062	12-24	.052 - .067	3/8	.270	.228	.062	.312	3/8	.239
FC1046-093	12-24	.084 - .099	3/8	.270	.228	.093	.281	3/8	.239
FC1046-125	12-24	.109 - .140	3/8	.270	.228	.125	.250	3/8	.239
FC1046-187	12-24	.171 - .203	3/8	.270	.228	.187	.188	3/8	.239
FC1046-250	12-24	.234 - .265	3/8	.270	.228	.250	.125	3/8	.239
FC1047-062	1/4-20	.052 - .067	1/2	.356	.295	.062	.375	7/16	.295
FC1047-093	1/4-20	.084 - .099	1/2	.356	.295	.093	.343	7/16	.295
FC1047-125	1/4-20	.109 - .140	1/2	.356	.295	.125	.312	7/16	.295
FC1047-187	1/4-20	.171 - .203	1/2	.356	.295	.187	.250	7/16	.295
FC1047-250	1/4-20	.234 - .265	1/2	.356	.295	.250	.187	7/16	.295
FC1048-062	1/4-28	.052 - .067	1/2	.356	.295	.062	.375	7/16	.295
FC1048-093	1/4-28	.084 - .099	1/2	.356	.295	.093	.343	7/16	.295
FC1048-125	1/4-28	.109 - .140	1/2	.356	.295	.125	.312	7/16	.295
FC1048-187	1/4-28	.171 - .203	1/2	.356	.295	.187	.250	7/16	.295
FC1048-250	1/4-28	.234 - .265	1/2	.356	.295	.250	.187	7/16	.295
FC1049-062	5/16-24	.052 - .067	1/2	.404	.343	.062	.375	7/16	.297
FC1049-093	5/16-24	.084 - .099	1/2	.404	.343	.093	.343	7/16	.297
FC1049-125	5/16-24	.109 - .140	1/2	.404	.343	.125	.312	7/16	.297
FC1049-187	5/16-24	.171 - .203	1/2	.404	.343	.187	.250	7/16	.297
FC1049-250	5/16-24	.234 - .265	1/2	.404	.343	.250	.187	7/16	.297

Create a part number

FCXXX-XXX XX XX

| | |

Length Material Finish

Material	
Material Code (XX)	
B	Brass
S	Steel
SS	Stainless Steel

See page 3 for finish codes



Fascomp Electronic Hardware
7814 Kingspointe Pkwy
Orlando, FL 32819
www.fascomp.com



Retainers—Type G

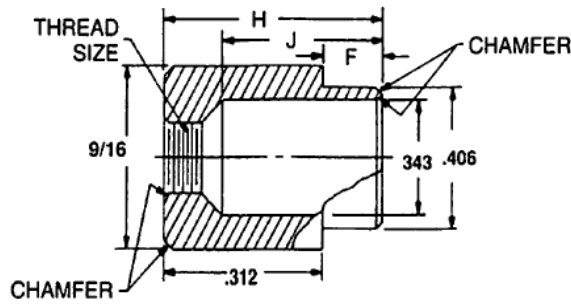

- Contact Sales Office for sizes not shown
- Source Control Drawing: To be produced by Fascomp Electronic Hardware

FCXXX-XXX	Thread	Panel Thickness	F +.005 -.005	H +.010 -.010	J +.005 -.005
FC1050-165	6-32	.109 - .140	.165	.477	.242
FC1050-230	6-32	.171 - .203	.230	.542	.307
FC1050-290	6-32	.234 - .265	.290	.602	.367
FC1051-165	8-32	.109 - .140	.165	.477	.248
FC1051-230	8-32	.171 - .203	.230	.542	.315
FC1051-290	8-32	.234 - .265	.290	.602	.373
FC1052-165	10-32	.109 - .140	.165	.477	.252
FC1052-230	10-32	.171 - .203	.230	.542	.318
FC1052-290	10-32	.234 - .265	.290	.602	.378
FC1053-165	12-24	.109 - .140	.165	.477	.256
FC1053-230	12-24	.171 - .203	.230	.542	.321
FC1053-290	10-24	.234 - .265	.290	.602	.381
FC1054-165	1/4-20	.109 - .140	.165	.477	.261
FC1054-230	1/4-20	.171 - .203	.230	.542	.326
FC1054-290	1/4-20	.234 - .265	.290	.602	.386

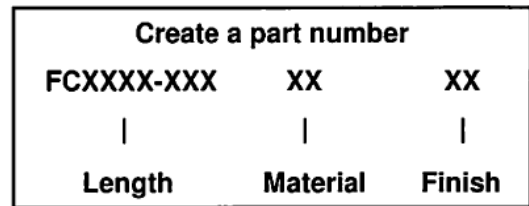

Material	
Material Code (XX)	
B	Brass
S	Steel
SS	Stainless Steel

See page 3 for finish codes



Fascomp Electronic Hardware
7814 Kingspointe Pkwy
Orlando, FL 32819
www.fascomp.com



Get quote »

Angic Global Solutions 1-888-872-0690
<https://www.AngicGlobal.com> Sales@AngicGlobal.com

Spacers



Fascomp stocks both hex and round Spacers in aluminum, brass, steel, and stainless steel.

Page No.

1/8 Round	63
3/16 Round	64
1/4 Round	65
5/16 Round	66
3/8 Round	67
1/2 Round	68
5/8 Round	69
3/4 Round	70
1" Round	71
1/8 Hex	72
3/16 Hex	73
1/4 Hex	74
5/16 Hex	75
3/8 Hex	76
1/2 Hex	77
5/8 Hex	78
3/4 Hex	79



Fascomp Electronic Hardware
 7814 Kingspointe Pkwy
 Orlando, FL 32819
 www.fascomp.com
 : (407) 226-2112

1/8 Round Spacers

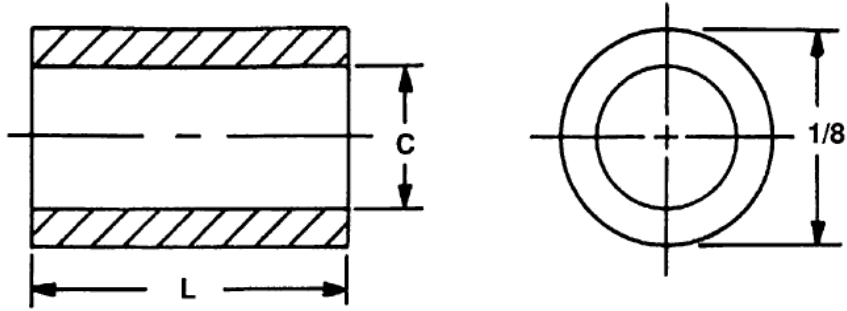

Create a part number			
FCXXX	XX	XX	XX
Length	Clearance	Material	Finish

- Contact Sales Office for sizes not shown
- Source Control Drawing: To be produced by Fascomp Electronic Hardware

FCXXX	Length (L)
FC1100	1/8
FC1101	3/16
FC1102	1/4
FC1103	5/16
FC1104	3/8
FC1105	7/16
FC1106	1/2

Hole Clearance Code (XX)	
Code (XX)	C
	+ .010
0	.064
2	.090

Material	
Material Code (XX)	
A	Aluminum
B	Brass
S	Steel
SS	Stainless Steel
N	Nylon

See page 3 for finish codes



Fascomp Electronic Hardware
 7814 Kingspointe Pkwy
 Orlando, FL 32819
 www.fascomp.com
 (407) 226-2112
 (407) 226-3370



Get quote >>

Angic Global Solutions

1-888-872-0690

<https://www.AngicGlobal.com> Sales@AngicGlobal.com

3/16 Round Spacers

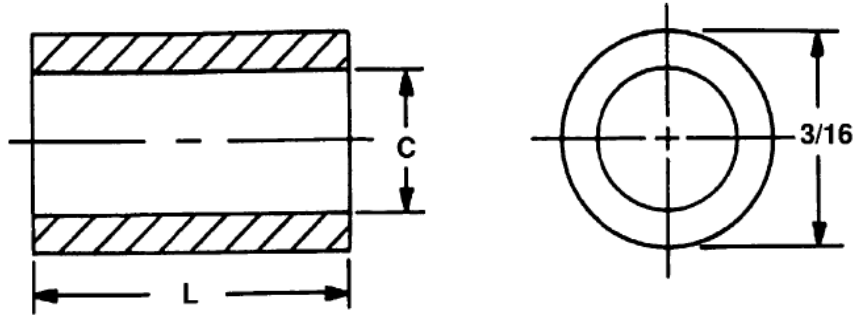

Create a part number			
FCXXX	XX	XX	XX
Length	Clearance	Material	Finish

- Contact Sales Office for sizes not shown
- Source Control Drawing: To be produced by Fascomp Electronic Hardware

FCXXX	Length (L)
FC1107	1/8
FC1108	3/16
FC1109	1/4
FC1110	5/16
FC1111	3/8
FC1112	7/16
FC1113	1/2
FC1114	9/16
FC1115	5/8
FC1116	11/16
FC1117	3/4
FC1118	13/16
FC1119	7/8
FC1120	15/16
FC1121	1

Hole Clearance Code (XX)	
Code (XX)	C + .010
2	.090
4	.115

Material	
Material Code (XX)	
A	Aluminum
B	Brass
S	Steel
SS	Stainless Steel
N	Nylon

See page 3 for finish codes



Fascomp Electronic Hardware
 7814 Kingspointe Pkwy
 Orlando, FL 32819
 www.fascomp.com
 (407) 226-2112
 (407) 226-3370



Get quote >>

1/4 Round Spacers

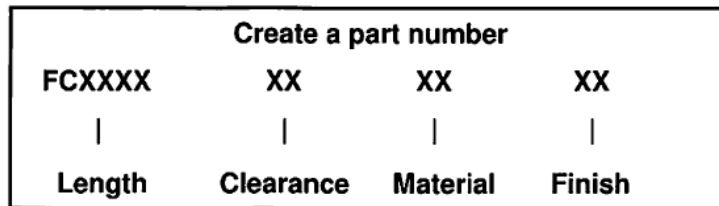
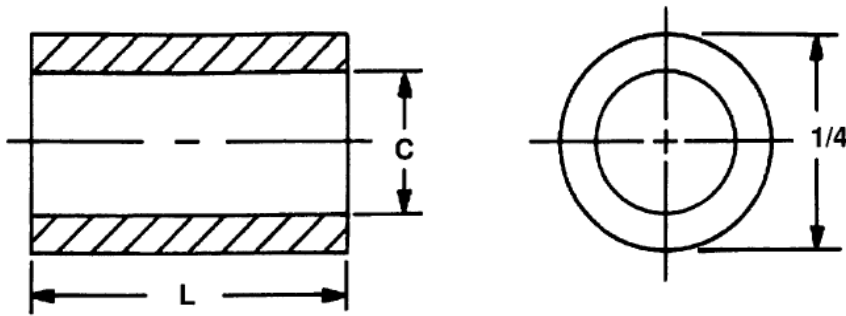

FCXXX	Length (L)
FC1122	1/8
FC1123	3/16
FC1124	1/4
FC1125	5/16
FC1126	3/8
FC1127	7/16
FC1128	1/2
FC1129	9/16
FC1130	5/8
FC1131	11/16
FC1132	3/4
FC1133	13/16
FC1134	7/8
FC1135	15/16
FC1136	1
FC1137	1-1/16
FC1138	1-1/8
FC1139	1-3/16
FC1140	1-1/4
FC1141	1-5/16
FC1142	1-3/8
FC1143	1-7/16
FC1144	1-1/2
FC1145	1-9/16
FC1146	1-5/8
FC1147	1-11/16
FC1148	1-3/4
FC1149	1-13/16
FC1150	1-7/8
FC1151	1-15/16
FC1152	2

Hole Clearance Code (XX)	
Code (XX)	C + .010
2	.090
4	.115
6	.140
8	.166

Material	
Material Code (XX)	
A	Aluminum
B	Brass
S	Steel
SS	Stainless Steel
N	Nylon

See page 3 for finish codes

- Contact Sales Office for sizes not shown
- Source Control Drawing: To be produced by Fascomp Electronic Hardware



Fascomp Electronic Hardware
 7814 Kingspointe Pkwy
 Orlando, FL 32819
 www.fascomp.com
 (407) 226-2112
 (407) 226-3370



Get quote >>

Angic Global Solutions

1-888-872-0690

<https://www.AngicGlobal.com> Sales@AngicGlobal.com

5/16 Round Spacers

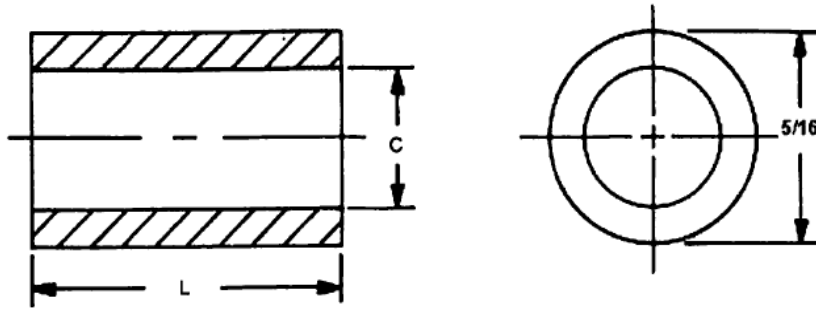

Create a part number			
FCXXXX	XX	XX	XX
Length	Clearance	Material	Finish

FCXXXX	Length (L)
FC1153	1/8
FC1154	3/16
FC1155	1/4
FC1156	5/16
FC1157	3/8
FC1158	7/16
FC1159	1/2
FC1160	9/16
FC1161	5/8
FC1162	11/16
FC1163	3/4
FC1164	13/16
FC1165	7/8
FC1166	15/16
FC1167	1
FC1168	1-1/16
FC1169	1-1/8
FC1170	1-3/16
FC1171	1-1/4
FC1172	1-5/16
FC1173	1-3/8
FC1174	1-7/16
FC1175	1-1/2
FC1176	1-9/16
FC1177	1-5/8
FC1178	1-11/16
FC1179	1-3/4
FC1180	1-13/16
FC1181	1-7/8
FC1182	1-15/16
FC1183	2

Hole Clearance Code (XX)	
Code (XX)	C + .010
4	.115
6	.140
8	.166
10	.192

Material	
Material Code (XX)	
A	Aluminum
B	Brass
S	Steel
SS	Stainless Steel
N	Nylon

See page 3 for finish codes

- Contact Sales Office for sizes not shown
- Source Control Drawing: To be produced by Fascomp Electronic Hardware



Fascomp Electronic Hardware
 7814 Kingspointe Pkwy
 Orlando, FL 32819
 www.fascomp.com
 Tel: (407) 226-2112
 Fax: (407) 226-3370

3/8 Round Spacers

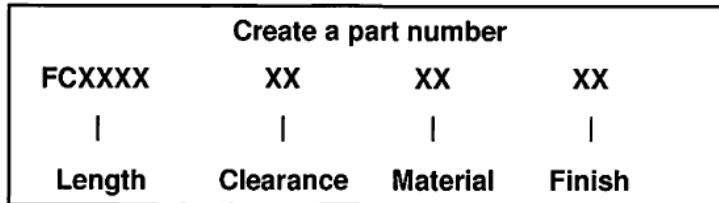
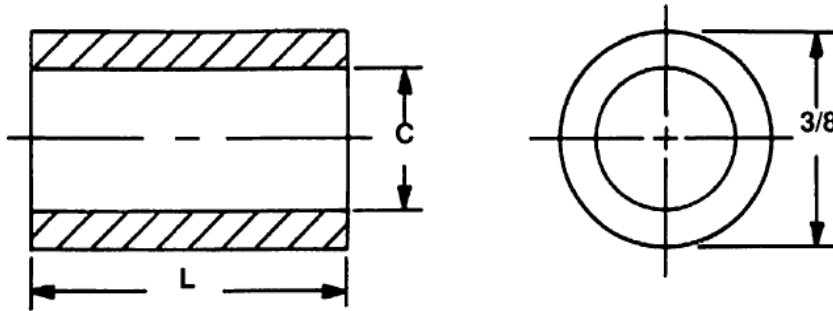

FCXXXX	Length (L)
FC1184	1/8
FC1185	3/16
FC1186	1/4
FC1187	5/16
FC1188	3/8
FC1189	7/16
FC1190	1/2
FC1191	9/16
FC1192	5/8
FC1193	11/16
FC1194	3/4
FC1195	13/16
FC1196	7/8
FC1197	15/16
FC1198	1
FC1199	1-1/16
FC1200	1-1/8
FC1201	1-3/16
FC1202	1-1/4
FC1203	1-5/16
FC1204	1-3/8
FC1205	1-7/16
FC1206	1-1/2
FC1207	1-9/16
FC1208	1-5/8
FC1209	1-11/16
FC1210	1-3/4
FC1211	1-13/16
FC1212	1-7/8
FC1213	1-15/16
FC1214	2

Hole Clearance Code (XX)	
Code (XX)	C
	+ .010
6	.140
8	.166
10	.192
12	.218

Material	
Material Code (XX)	
A	Aluminum
B	Brass
S	Steel
SS	Stainless Steel
N	Nylon

See page 3 for finish codes

- Contact Sales Office for sizes not shown
- Source Control Drawing: To be produced by Fascomp Electronic Hardware



Fascomp Electronic Hardware
 7814 Kingspointe Pkwy
 Orlando, FL 32819
 www.fascomp.com
 Tel: (407) 226-2112
 Fax: (407) 226-3376



Get quote >>

Angic Global Solutions

1-888-872-0690

<https://www.AngicGlobal.com>
 Sales@AngicGlobal.com

1/2 Round Spacers

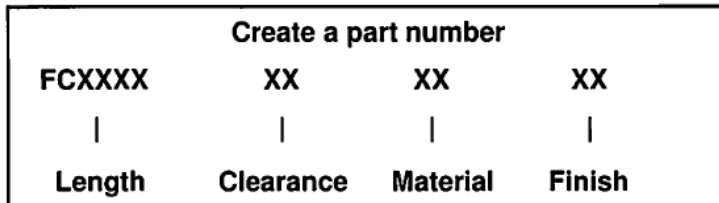
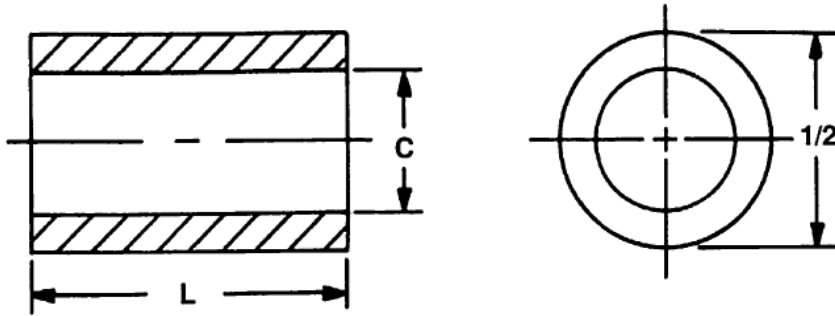

FCXXXX	Length (L)
FC1215	1/8
FC1216	3/16
FC1217	1/4
FC1218	5/16
FC1219	3/8
FC1220	7/16
FC1221	1/2
FC1222	9/16
FC1223	5/8
FC1224	11/16
FC1225	3/4
FC1226	13/16
FC1227	7/8
FC1228	15/16
FC1229	1
FC1230	1-1/16
FC1231	1-1/8
FC1232	1-3/16
FC1233	1-1/4
FC1234	1-5/16
FC1235	1-3/8
FC1236	1-7/16
FC1237	1-1/2
FC1238	1-9/16
FC1239	1-5/8
FC1240	1-11/16
FC1241	1-3/4
FC1242	1-13/16
FC1243	1-7/8
FC1244	1-15/16
FC1245	2

Hole Clearance Code (XX)	
Code (XX)	C + .010
6	.140
8	.166
10	.192
12	.218
25	.252

Material	
Material Code (XX)	
A	Aluminum
B	Brass
S	Steel
SS	Stainless Steel
N	Nylon

See page 3 for finish codes

- Contact Sales Office for sizes not shown
- Source Control Drawing: To be produced by Fascomp Electronic Hardware



Fascomp Electronic Hardware
 7814 Kingspointe Pkwy
 Orlando, FL 32819
 www.fascomp.com
 (407) 226-2112
 (407) 226-3370



5/8 Round Spacers

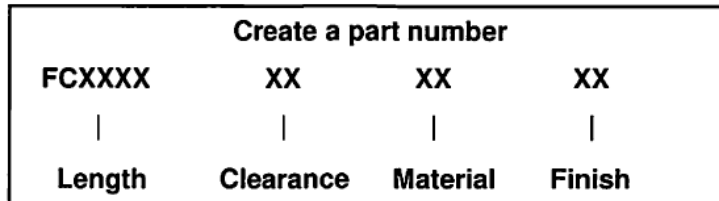
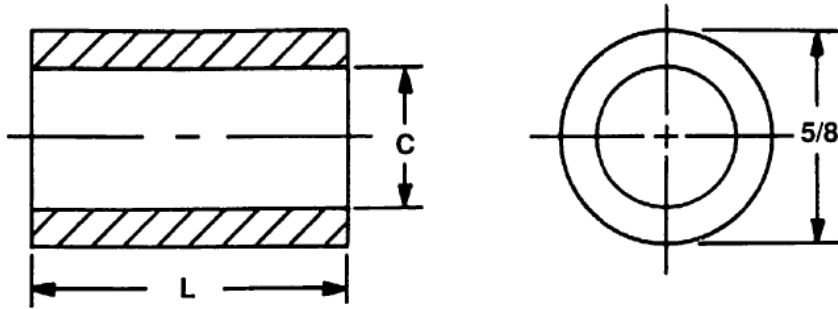

FCXXXX	Length (L)
FC1246	1/8
FC1247	3/16
FC1248	1/4
FC1249	5/16
FC1250	3/8
FC1251	7/16
FC1252	1/2
FC1253	9/16
FC1254	5/8
FC1255	11/16
FC1256	3/4
FC1257	13/16
FC1258	7/8
FC1259	15/16
FC1260	1
FC1261	1-1/16
FC1262	1-1/8
FC1263	1-3/16
FC1264	1-1/4
FC1265	1-5/16
FC1266	1-3/8
FC1267	1-7/16
FC1268	1-1/2
FC1269	1-9/16
FC1270	1-5/8
FC1271	1-11/16
FC1272	1-3/4
FC1273	1-13/16
FC1274	1-7/8
FC1275	1-15/16
FC1276	2

Hole Clearance Code (XX)	
Code (XX)	C + .010
6	.140
8	.166
10	.192
12	.218
25	.252
31	.315
38	.380

Material	
Material Code (XX)	
A	Aluminum
B	Brass
S	Steel
SS	Stainless Steel
N	Nylon

See page 3 for finish codes

- Contact Sales Office for sizes not shown
- Source Control Drawing: To be produced by Fascomp Electronic Hardware



Fascomp Electronic Hardware
 7814 Kingspointe Pkwy
 Orlando, FL 32819
 www.fascomp.com
 tel: (407) 226-2111
 fax: (407) 226-3377



Get quote >>

Angic Global Solutions

1-888-872-0690

<https://www.AngicGlobal.com> Sales@AngicGlobal.com

3/4 Round Spacers

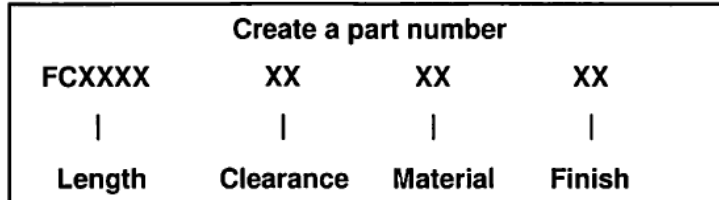
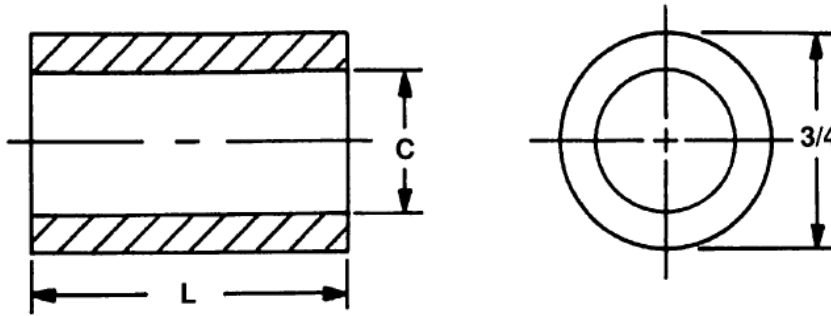

FCXXXX	Length (L)
FC1277	1/8
FC1278	3/16
FC1279	1/4
FC1280	5/16
FC1281	3/8
FC1282	7/16
FC1283	1/2
FC1284	9/16
FC1285	5/8
FC1286	11/16
FC1287	3/4
FC1288	13/16
FC1289	7/8
FC1290	15/16
FC1291	1
FC1292	1-1/16
FC1293	1-1/8
FC1294	1-3/16
FC1295	1-1/4
FC1296	1-5/16
FC1297	1-3/8
FC1298	1-7/16
FC1299	1-1/2
FC1300	1-9/16
FC1301	1-5/8
FC1302	1-11/16
FC1303	1-3/4
FC1304	1-13/16
FC1305	1-7/8
FC1306	1-15/16
FC1307	2

Hole Clearance Code (XX)	
Code (XX)	C
	+ .010
6	.140
8	.166
10	.192
12	.218
25	.252
31	.315
38	.380
43	.440
50	.505

Material	
Material Code (XX)	
A	Aluminum
B	Brass
S	Steel
SS	Stainless Steel
N	Nylon

See page 3 for finish codes

- Contact Sales Office for sizes not shown
- Source Control Drawing: To be produced by Fascomp Electronic Hardware



Fascomp Electronic Hardware
 7814 Kingspointe Pkwy
 Orlando, FL 32819
 www.fascomp.com
 Tel: (407) 226-2111
 Fax: (407) 226-3377



1" Round Spacers

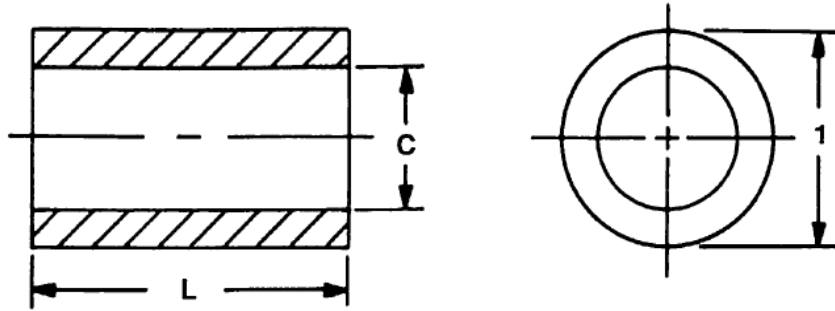

Create a part number			
FCXXXXXXXX	XX	XX	XX
Length	Clearance	Material	Finish

- Contact Sales Office for sizes not shown
- Source Control Drawing: To be produced by Fascomp Electronic Hardware

FCXXXXXXXX	Length (L)
FC1277OD1"	1/8
FC1279OD1"	1/4
FC1281OD1"	3/8
FC1283OD1"	1/2
FC1285OD1"	5/8
FC1287OD1"	3/4
FC1289OD1"	7/8
FC1291OD1"	1

Hole Clearance Code (XX)	
Code (XX)	C + .010
6	.140
8	.166
10	.192
12	.218
25	.252
31	.315
38	.380
43	.440
50	.505

Material	
Material Code (XX)	
A	Aluminum
B	Brass
S	Steel
SS	Stainless Steel
N	Nylon

See page 3 for finish codes



Fascomp Electronic Hardware
 7814 Kingspointe Pkwy
 Orlando, FL 32819
 www.fascomp.com
 407) 226-2112
 407) 226-3370



Get quote >>

Angic Global Solutions

1-888-872-0690

<https://www.AngicGlobal.com> Sales@AngicGlobal.com

1/8 Hex Spacers

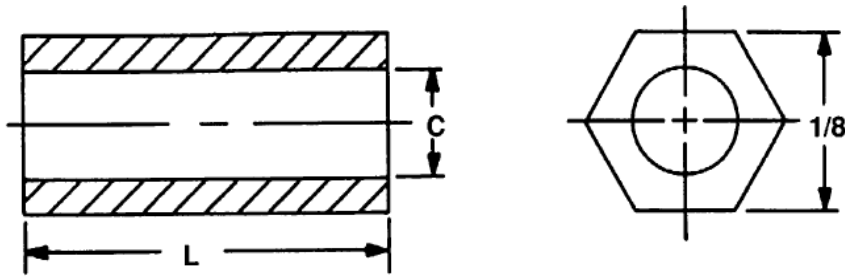

Create a part number			
FCXXX	XX	XX	XX
Length	Clearance	Material	Finish

- Contact Sales Office for sizes not shown
- Source Control Drawing: To be produced by Fascomp Electronic Hardware

FCXXX	Length (L)
FC1308	1/8
FC1309	3/16
FC1310	1/4
FC1311	5/16
FC1312	3/8
FC1313	7/16
FC1314	1/2

Hole Clearance Code (XX)	
Code (XX)	C
	+ .010
0	.064
2	.090

Material	
Material Code (XX)	
A	Aluminum
B	Brass
S	Steel
SS	Stainless Steel
N	Nylon

See page 3 for finish codes



Fascomp Electronic Hardware
 7814 Kingspointe Pkwy
 Orlando, FL 32819
 www.fascomp.com
 (407) 226-2112
 (407) 226-3370



Get quote >>

3/16 Hex Spacers

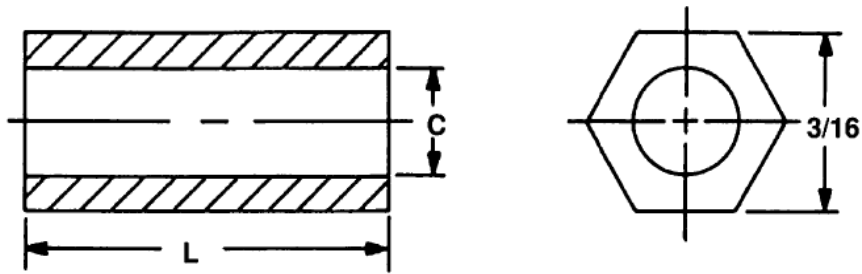

Create a part number			
FCXXXX	XX	XX	XX
Length	Clearance	Material	Finish

- Contact Sales Office for sizes not shown
- Source Control Drawing: To be produced by Fascomp Electronic Hardware

FCXXXX	Length (L)
FC1315	1/8
FC1316	3/16
FC1317	1/4
FC1318	5/16
FC1319	3/8
FC1320	7/16
FC1321	1/2
FC1322	9/16
FC1323	5/8
FC1324	11/16
FC1325	3/4
FC1326	13/16
FC1327	7/8
FC1328	15/16
FC1329	1

Hole Clearance Code (XX)	
Code (XX)	C + .010
2	.090
4	.115

Material	
Material Code (XX)	
A	Aluminum
B	Brass
S	Steel
SS	Stainless Steel
N	Nylon

See page 3 for finish codes



Fascomp Electronic Hardware
 7814 Kingspointe Pkwy
 Orlando, FL 32819
 www.fascomp.com
 07) 226-2112
 07) 226-3370



Get quote >>

Angic Global Solutions 1-888-872-0690
<https://www.AngicGlobal.com> Sales@AngicGlobal.com

1/4 Hex Spacers

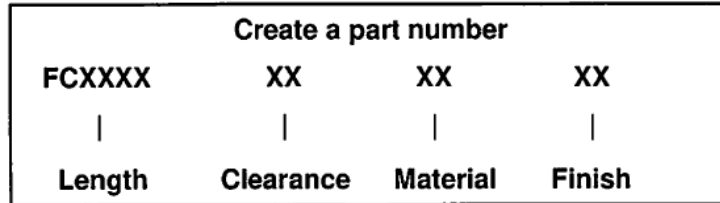
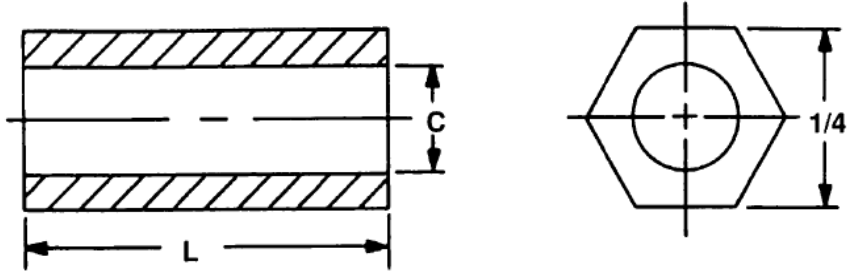

FCXXX	Length (L)
FC1330	1/8
FC1331	3/16
FC1332	1/4
FC1333	5/16
FC1334	3/8
FC1335	7/16
FC1336	1/2
FC1337	9/16
FC1338	5/8
FC1339	11/16
FC1340	3/4
FC1341	13/16
FC1342	7/8
FC1343	15/16
FC1344	1
FC1345	1-1/16
FC1346	1-1/8
FC1347	1-3/16
FC1348	1-1/4
FC1349	1-5/16
FC1350	1-3/8
FC1351	1-7/16
FC1352	1-1/2
FC1353	1-9/16
FC1354	1-5/8
FC1355	1-11/16
FC1356	1-3/4
FC1357	1-13/16
FC1358	1-7/8
FC1359	1-15/16
FC1360	2

Hole Clearance Code (XX)	
Code (XX)	C + .010
2	.090
4	.115
6	.140
8	.166

Material	
Material Code (XX)	
A	Aluminum
B	Brass
S	Steel
SS	Stainless Steel
N	Nylon

See page 3 for finish codes

- Contact Sales Office for sizes not shown
- Source Control Drawing: To be produced by Fascomp Electronic Hardware



Fascomp Electronic Hardware
 7814 Kingspointe Pkwy
 Orlando, FL 32819
www.fascomp.com
 (407) 226-2112
 (407) 226-3370



Get quote »

5/16 Hex Spacers

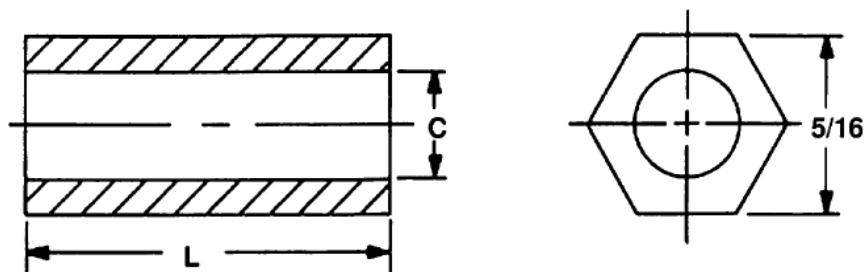

Create a part number			
FCXXX	XX	XX	XX
Length	Clearance	Material	Finish

FCXXX	Length (L)
FC1361	1/8
FC1362	3/16
FC1363	1/4
FC1364	5/16
FC1365	3/8
FC1366	7/16
FC1367	1/2
FC1368	9/16
FC1369	5/8
FC1370	11/16
FC1371	3/4
FC1372	13/16
FC1373	7/8
FC1374	15/16
FC1375	1
FC1376	1-1/16
FC1377	1-1/8
FC1378	1-3/16
FC1379	1-1/4
FC1380	1-5/16
FC1381	1-3/8
FC1382	1-7/16
FC1383	1-1/2
FC1384	1-9/16
FC1385	1-5/8
FC1386	1-11/16
FC1387	1-3/4
FC1388	1-13/16
FC1389	1-7/8
FC1390	1-15/16
FC1391	2

Hole Clearance Code (XX)	
Code (XX)	C + .010
4	.115
6	.140
8	.166
10	.192

Material	
Material Code (XX)	
A	Aluminum
B	Brass
S	Steel
SS	Stainless Steel
N	Nylon

See page 3 for finish codes

- Contact Sales Office for sizes not shown
- Source Control Drawing: To be produced by Fascomp Electronic Hardware



Fascomp Electronic Hardware
 7814 Kingspointe Pkwy
 Orlando, FL 32819
 www.fascomp.com
 Tel: (407) 226-2112
 Fax: (407) 226-3376



Get quote >>

Angic Global Solutions

1-888-872-0690

<https://www.AngicGlobal.com> Sales@AngicGlobal.com

3/8 Hex Spacers

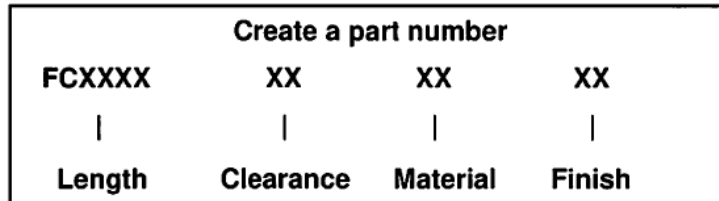
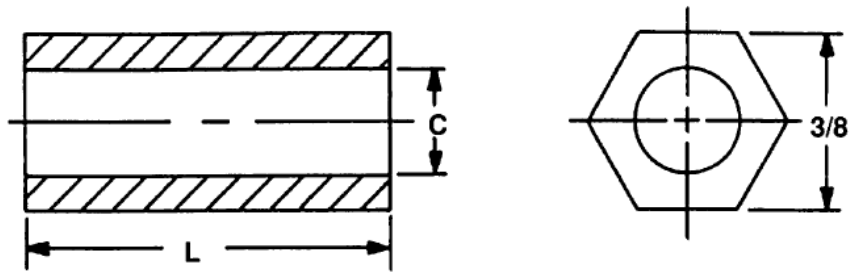

FCXXXX	Length (L)
FC1392	1/8
FC1393	3/16
FC1394	1/4
FC1395	5/16
FC1396	3/8
FC1397	7/16
FC1398	1/2
FC1399	9/16
FC1400	5/8
FC1401	11/16
FC1402	3/4
FC1403	13/16
FC1404	7/8
FC1405	15/16
FC1406	1
FC1407	1-1/16
FC1408	1-1/8
FC1409	1-3/16
FC1410	1-1/4
FC1411	1-5/16
FC1412	1-3/8
FC1413	1-7/16
FC1414	1-1/2
FC1415	1-9/16
FC1416	1-5/8
FC1417	1-11/16
FC1418	1-3/4
FC1419	1-13/16
FC1420	1-7/8
FC1421	1-15/16
FC1422	2

Hole Clearance Code (XX)	
Code (XX)	C + .010
6	.140
8	.166
10	.192
12	.218

Material	
Material Code (XX)	
A	Aluminum
B	Brass
S	Steel
SS	Stainless Steel
N	Nylon

See page 3 for finish codes

- Contact Sales Office for sizes not shown
- Source Control Drawing: To be produced by Fascomp Electronic Hardware



Fascomp Electronic Hardware
7814 Kingspointe Pkwy
Orlando, FL 32819
www.fascomp.com
:(407) 226-2112
:(407) 226-3370



Get quote >>

1/2 Hex Spacers

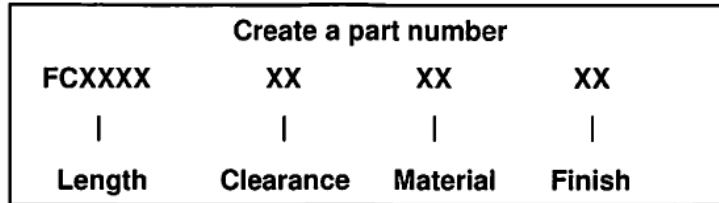
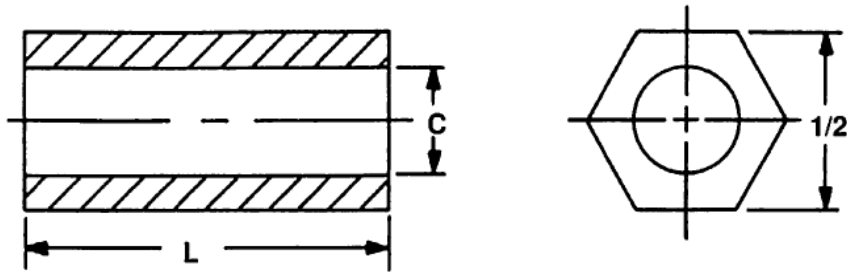

FCXXXX	Length (L)
FC1423	1/8
FC1424	3/16
FC1425	1/4
FC1426	5/16
FC1427	3/8
FC1428	7/16
FC1429	1/2
FC1430	9/16
FC1431	5/8
FC1432	11/16
FC1433	3/4
FC1434	13/16
FC1435	7/8
FC1436	15/16
FC1437	1
FC1438	1-1/16
FC1439	1-1/8
FC1440	1-3/16
FC1441	1-1/4
FC1442	1-5/16
FC1443	1-3/8
FC1444	1-7/16
FC1445	1-1/2
FC1446	1-9/16
FC1447	1-5/8
FC1448	1-11/16
FC1449	1-3/4
FC1450	1-13/16
FC1451	1-7/8
FC1452	1-15/16
FC1453	2

Hole Clearance Code (XX)	
Code (XX)	C + .010
6	.140
8	.166
10	.192
12	.218
25	.252

Material	
Material Code (XX)	
A	Aluminum
B	Brass
S	Steel
SS	Stainless Steel
N	Nylon

See page 3 for finish codes

- Contact Sales Office for sizes not shown
- Source Control Drawing: To be produced by Fascomp Electronic Hardware



Fascomp Electronic Hardware
 7814 Kingspointe Pkwy
 Orlando, FL 32819
 www.fascomp.com
 Tel: (407) 226-2117
 Fax: (407) 226-3371



Get quote >>

Angic Global Solutions

1-888-872-0690

<https://www.AngicGlobal.com> Sales@AngicGlobal.com

5/8 Hex Spacers

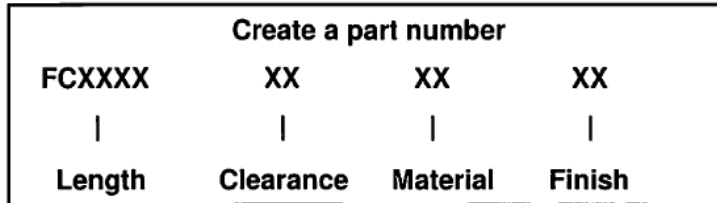
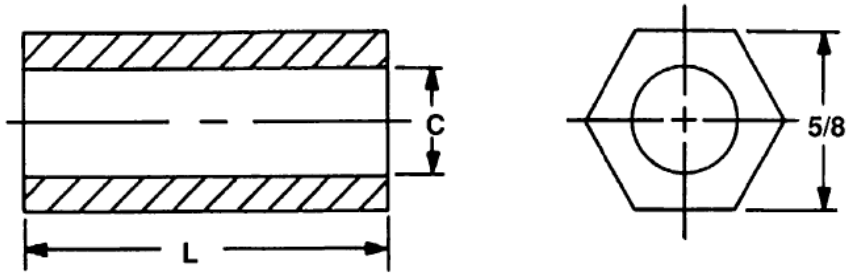

FCXXXX	Length (L)
FC1454	1/8
FC1455	3/16
FC1456	1/4
FC1457	5/16
FC1458	3/8
FC1459	7/16
FC1460	1/2
FC1461	9/16
FC1462	5/8
FC1463	11/16
FC1464	3/4
FC1465	13/16
FC1466	7/8
FC1467	15/16
FC1468	1
FC1469	1-1/16
FC1470	1-1/8
FC1471	1-3/16
FC1472	1-1/4
FC1473	1-5/16
FC1474	1-3/8
FC1475	1-7/16
FC1476	1-1/2
FC1477	1-9/16
FC1478	1-5/8
FC1479	1-11/16
FC1480	1-3/4
FC1481	1-13/16
FC1482	1-7/8
FC1483	1-15/16
FC1484	2

Hole Clearance Code (XX)	
Code (XX)	C + .010
6	.140
8	.166
10	.192
12	.218
25	.252
31	.315
38	.380

Material	
Material Code (XX)	
A	Aluminum
B	Brass
S	Steel
SS	Stainless Steel
N	Nylon

See page 3 for finish codes

- **Contact Sales Office for sizes not shown**
- **Source Control Drawing: To be produced by Fascomp Electronic Hardware**



Fascomp Electronic Hardware
 7814 Kingspointe Pkwy
 Orlando, FL 32819
 www.fascomp.com
 : (407) 226-2112
 : (407) 226-3370



3/4 Hex Spacers

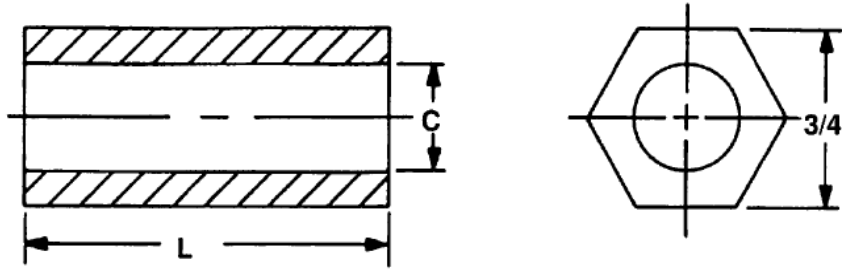

FCXXXX	Length (L)
FC1485	1/8
FC1486	3/16
FC1487	1/4
FC1488	5/16
FC1489	3/8
FC1490	7/16
FC1491	1/2
FC1492	9/16
FC1493	5/8
FC1494	11/16
FC1495	3/4
FC1496	13/16
FC1497	7/8
FC1498	15/16
FC1499	1
FC1500	1-1/16
FC1501	1-1/8
FC1502	1-3/16
FC1503	1-1/4
FC1504	1-5/16
FC1505	1-3/8
FC1506	1-7/16
FC1507	1-1/2
FC1508	1-9/16
FC1509	1-5/8
FC1510	1-11/16
FC1511	1-3/4
FC1512	1-13/16
FC1513	1-7/8
FC1514	1-15/16
FC1515	2

Create a part number			
FCXXXX	XX	XX	XX
Length	Clearance	Material	Finish

Hole Clearance Code (XX)	
Code (XX)	C + .010
6	.140
8	.166
10	.192
12	.218
25	.252
31	.315
38	.380
43	.440
50	.505

Material	
Material Code (XX)	
A	Aluminum
B	Brass
S	Steel
SS	Stainless Steel
N	Nylon

See page 3 for finish codes

- Contact Sales Office for sizes not shown
- Source Control Drawing: To be produced by Fascomp Electronic Hardware



Fascomp Electronic Hardware
 7814 Kingspointe Pkwy
 Orlando, FL 32819
 www.fascomp.com
 (407) 226-2112
 (407) 226-3370



Get quote >>

Angic Global Solutions

1-888-872-0690

<https://www.AngicGlobal.com> Sales@AngicGlobal.com



Swage Spacers



Fascomp stocks both hex and round Swage Spacers in aluminum, brass, steel, and stainless steel.

	Page No.
3/16 Round	81
1/4 Round	82
3/16 Hex	83
1/4 Hex	84



Fascomp Electronic Hardware
7814 Kingspointe Pkwy
Orlando, FL 32819
www.fascomp.com
Tel: (407) 226-2112



3/16 Round Swage Spacers

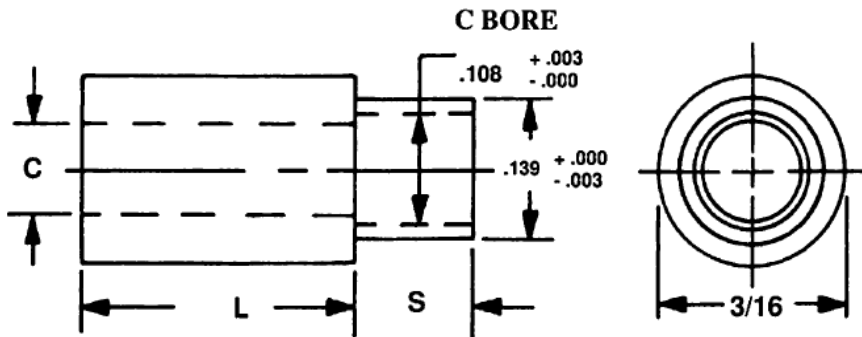

Create a part number				
FCXXXX	X	XX	XX	XX
Length	Panel/Code	Clearance	Material	Finish

- Contact Sales Office for sizes not shown
- Source Control Drawing: To be produced by Fascomp Electronic Hardware

FCXXXX	Length (L)
FC1516	1/8
FC1517	3/16
FC1518	1/4
FC1519	5/16
FC1520	3/8
FC1521	7/16
FC1522	1/2
FC1523	9/16
FC1524	5/8
FC1525	11/16
FC1526	3/4
FC1527	13/16
FC1528	7/8
FC1529	15/16
FC1530	1

Swage Panel/Code (X)		
S	+ .003 - .003	P
A	.075	1/32
B	.105	1/16
C	.135	3/32
D	.165	1/8
E	.230	3/16
F	.290	1/4

Hole Clearance Code (XX)	
Code (XX)	C + .010 - .000
2	.090
3	.101

Material	
Material Code (XX)	
A	Aluminum
B	Brass
S	Steel
SS	Stainless Steel

See page 3 for finish codes



Fascomp Electronic Hardware
 7814 Kingspointe Pkwy
 Orlando, FL 32819
 www.fascomp.com
 (407) 226-2112
 (407) 226-3370



Get quote >>

Angic Global Solutions

1-888-872-0690

<https://www.AngicGlobal.com> Sales@AngicGlobal.com

1/4 Round Swage Spacers

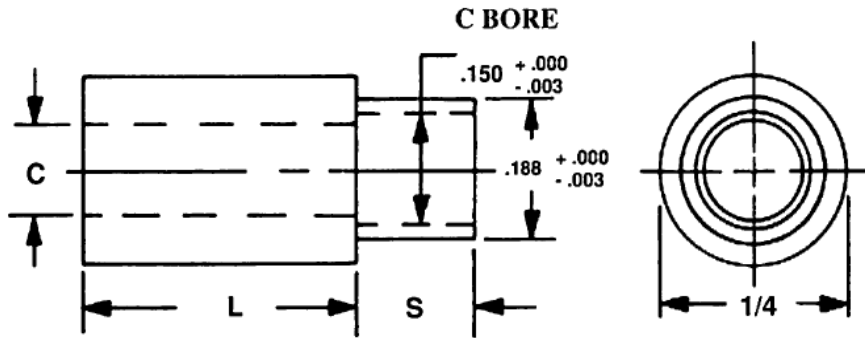

Create a part number				
FCXXXX	X	XX	XX	XX
Length	Panel/Code	Clearance	Material	Finish

- Contact Sales Office for sizes not shown
- Source Control Drawing: To be produced by Fascomp Electronic Hardware

FCXXXX	Length (L)
FC1531	1/8
FC1532	3/16
FC1533	1/4
FC1534	5/16
FC1535	3/8
FC1536	7/16
FC1537	1/2
FC1538	9/16
FC1539	5/8
FC1540	11/16
FC1541	3/4
FC1542	13/16
FC1543	7/8
FC1544	15/16
FC1545	1

Swage Panel/Code (X)		
S	+ .003 - .003	P
A	.075	1/32
B	.105	1/16
C	.135	3/32
D	.165	1/8
E	.230	3/16
F	.290	1/4

Hole Clearance Code (XX)	
Code (XX)	C + .010 - .000
2	.090
3	.101
4	.115
6	.140

Material	
Material Code (XX)	
A	Aluminum
B	Brass
S	Steel
SS	Stainless Steel

See page 3 for finish codes



Fascomp Electronic Hardware
7814 Kingspointe Pkwy
Orlando, FL 32819
www.fascomp.com
7) 226-2112
7) 226-3370

3/16 Hex Swage Spacers

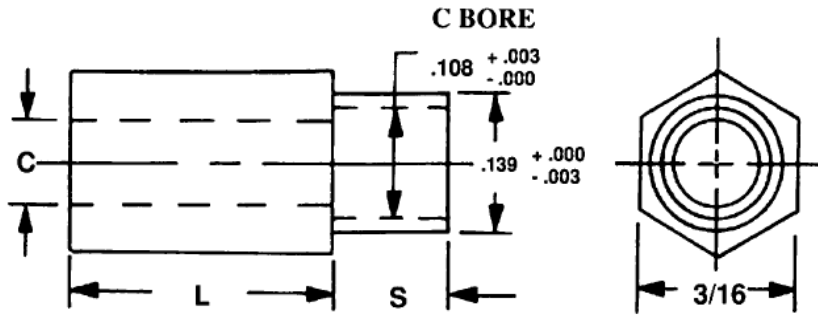

Create a part number				
FCXXXX	X	XX	XX	XX
Length	Panel/Code	Clearance	Material	Finish

- Contact Sales Office for sizes not shown
- Source Control Drawing: To be produced by Fascomp Electronic Hardware

FCXXXX	Length (L)
FC1546	1/8
FC1547	3/16
FC1548	1/4
FC1549	5/16
FC1550	3/8
FC1551	7/16
FC1552	1/2
FC1553	9/16
FC1554	5/8
FC1555	11/16
FC1556	3/4
FC1557	13/16
FC1558	7/8
FC1559	15/16
FC1560	1

Swage Panel/Code (X)		
S	+ .003 - .003	P
A	.075	1/32
B	.105	1/16
C	.135	3/32
D	.165	1/8
E	.230	3/16
F	.290	1/4

Hole Clearance Code (XX)	
Code (XX)	C + .010 - .000
2	.090
3	.101

Material	
Material Code (XX)	
A	Aluminum
B	Brass
S	Steel
SS	Stainless Steel

See page 3 for finish codes



Fascomp Electronic Hardware
 7814 Kingspointe Pkwy
 Orlando, FL 32819
 www.fascomp.com
 (407) 226-2112
 (407) 226-3370



Get quote >>

Angic Global Solutions 1-888-872-0690
<https://www.AngicGlobal.com> Sales@AngicGlobal.com

1/4 Hex Swage Spacers

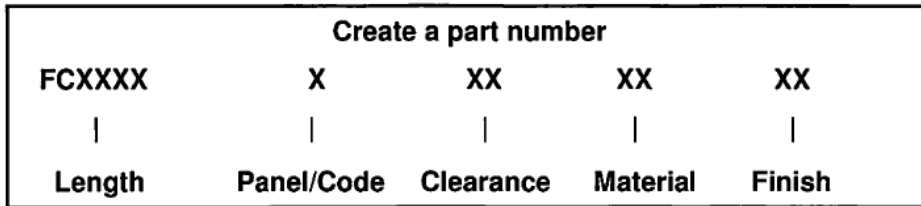
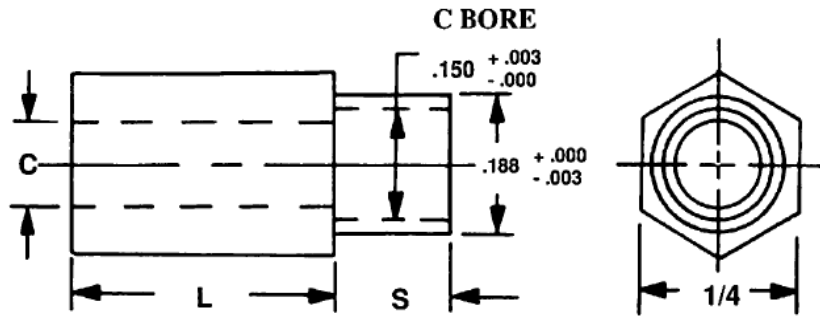

- Contact Sales Office for sizes not shown
- Source Control Drawing: To be produced by Fascomp Electronic Hardware

FCXXX	Length (L)
FC1561	1/8
FC1562	3/16
FC1563	1/4
FC1564	5/16
FC1565	3/8
FC1566	7/16
FC1567	1/2
FC1568	9/16
FC1569	5/8
FC1570	11/16
FC1571	3/4
FC1572	13/16
FC1573	7/8
FC1574	15/16
FC1575	1

Swage Panel/Code (X)		
S	+ .003 - .003	P
A	.075	1/32
B	.105	1/16
C	.135	3/32
D	.165	1/8
E	.230	3/16
F	.290	1/4

Hole Clearance Code (XX)	
Code (XX)	C + .010 - .000
2	.090
3	.101
4	.115
6	.140

Material	
Material Code (XX)	
A	Aluminum
B	Brass
S	Steel
SS	Stainless Steel

See page 3 for finish codes



Fascomp Electronic Hardware
7814 Kingspointe Pkwy
Orlando, FL 32819
www.fascomp.com
(7) 226-2112
(7) 226-3370





Female Standoffs



Fascomp stocks both hex and round Female Standoffs in aluminum, brass, steel, stainless steel and nylon.

Page No.

1/8 Round	86
3/16 Round	87
1/4 Round	88
5/16 Round	89
3/8 Round	90
1/2 Round	91
5/8 Round	92
1/8 Hex	93
3/16 Hex	94
1/4 Hex	95
5/16 Hex	96
3/8 Hex	97
1/2 Hex	98
5/8 Hex	99



Fascomp Electronic Hardware
7814 Kingspointe Pkwy
Orlando, FL 32819
www.fascomp.com
Tel: (407) 226-2112
Fax: (407) 226-3370



Get quote >>

Angic Global Solutions

1-888-872-0690

<https://www.AngicGlobal.com> Sales@AngicGlobal.com

1/8 Round Female Standoff

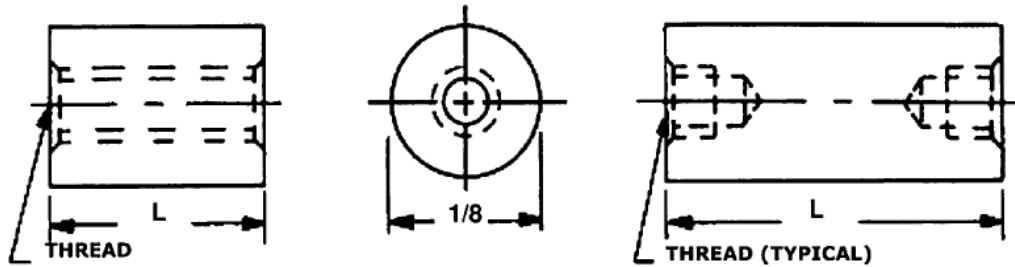

- Contact Sales Office for sizes not shown
- Source Control Drawing: To be produced by Fascomp Electronic Hardware

FCXXXX	Length (L)
FC1600	1/8
FC1601	3/16
FC1602	1/4
FC1603	5/16
FC1604	3/8
FC1605	7/16
FC1606	1/2
FC1607	9/16
FC1608	5/8
FC1609	11/16
FC1610	3/4
FC1611	13/16
FC1612	7/8
FC1613	15/16
FC1614	1
FC1615	1-1/16
FC1616	1-1/8
FC1617	1-3/16
FC1618	1-1/4
FC1619	1-5/16
FC1620	1-3/8
FC1621	1-7/16
FC1622	1-1/2
FC1623	1-9/16
FC1624	1-5/8
FC1625	1-11/16
FC1626	1-3/4
FC1627	1-13/16
FC1628	1-7/8
FC1629	1-15/16
FC1630	2

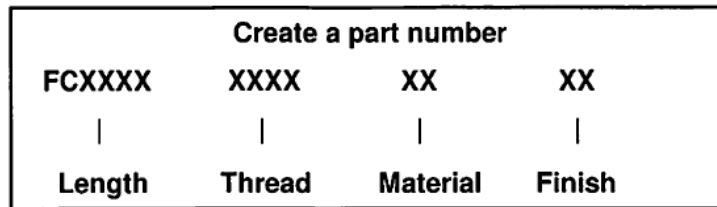

Thread			
Thread Code (XXX)	Tapped Thru		Longer Parts
	A, B, S	SS	Blind Tap Depth
080	3/8	1/4	3/16
256	3/4	5/8	3/16

Aluminum (A), Brass (B), Steel (S), Stainless Steel (SS)

Material	
Material Code (XX)	
A	Aluminum
B	Brass
S	Steel
SS	Stainless Steel
N	Nylon

See page 3 for finish codes



Fascomp Electronic Hardware
 7814 Kingspointe Pkwy
 Orlando, FL 32819
 www.fascomp.com
 Tel: (407) 226-2117
 Fax: (407) 226-3371



3/16 Round Female Standoff

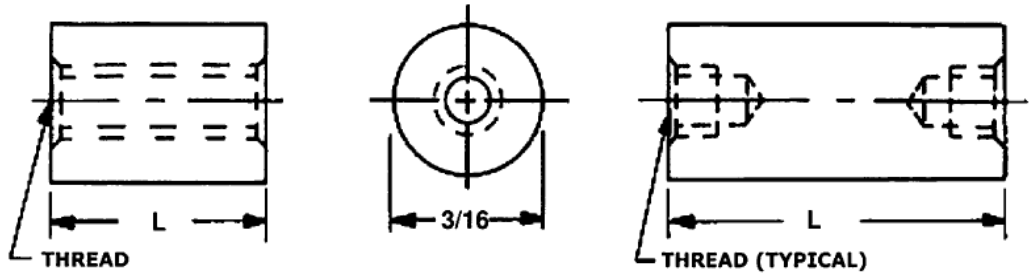

FCXXXX	Length (L)
FC1631	1/8
FC1632	3/16
FC1633	1/4
FC1634	5/16
FC1635	3/8
FC1636	7/16
FC1637	1/2
FC1638	9/16
FC1639	5/8
FC1640	11/16
FC1641	3/4
FC1642	13/16
FC1643	7/8
FC1644	15/16
FC1645	1
FC1646	1-1/16
FC1647	1-1/8
FC1648	1-3/16
FC1649	1-1/4
FC1650	1-5/16
FC1651	1-3/8
FC1652	1-7/16
FC1653	1-1/2
FC1654	1-9/16
FC1655	1-5/8
FC1656	1-11/16
FC1657	1-3/4
FC1658	1-13/16
FC1659	1-7/8
FC1660	1-15/16
FC1661	2
FC1662	2-1/16
FC1663	2-1/8
FC1664	2-3/16
FC1665	2-1/4
FC1666	2-5/16
FC1667	2-3/8
FC1668	2-7/16
FC1669	2-1/2
FC1670	2-9/16
FC1671	2-5/8
FC1672	2-11/16
FC1673	2-3/4
FC1674	2-13/16
FC1675	2-7/8
FC1676	2-15/16
FC1677	

- Contact Sales Office for sizes not shown
- Source Control Drawing: To be produced by Fascomp Electronic Hardware

Create a part number			
FCXXXX	XXXX	XX	XX
Length	Thread	Material	Finish

Thread			
Thread Code (XXX)	Tapped Thru		Longer Parts
	A, B, S	SS	Blind Tap Depth
256	3/4	5/8	3/16
440	1	3/4	1/4

Aluminum (A), Brass (B), Steel (S), Stainless Steel (SS)

Material	
Material Code (XX)	
A	Aluminum
B	Brass
S	Steel
SS	Stainless Steel
N	Nylon

See page 3 for finish codes



Fascomp Electronic Hardware
 7814 Kingspointe Pkwy
 Orlando, FL 32819
 www.fascomp.com
 Tel: (407) 226-21
 Fax: (407) 226-33



Get quote >>

Angic Global Solutions 1-888-872-0690
<https://www.AngicGlobal.com> Sales@AngicGlobal.com

1/4 Round Female Standoff

FCXXX	Length (L)
FC1678	1/8
FC1679	3/16
FC1680	1/4
FC1681	5/16
FC1682	3/8
FC1683	7/16
FC1684	1/2
FC1685	9/16
FC1686	5/8
FC1687	11/16
FC1688	3/4
FC1689	13/16
FC1690	7/8
FC1691	15/16
FC1692	1
FC1693	1-1/16
FC1694	1-1/8
FC1695	1-3/16
FC1696	1-1/4
FC1697	1-5/16
FC1698	1-3/8
FC1699	1-7/16
FC1700	1-1/2
FC1701	1-9/16
FC1702	1-5/8
FC1703	1-11/16
FC1704	1-3/4
FC1705	1-13/16
FC1706	1-7/8
FC1707	1-15/16
FC1708	2
FC1709	2-1/8
FC1710	2-1/4
FC1711	2-3/8
FC1712	2-1/2
FC1713	2-5/8
FC1714	2-3/4
FC1715	2-7/8
FC1716	3
FC1717	3-1/4
FC1718	3-1/2
FC1719	3-3/4
FC1720	4
FC1721	4-1/4
FC1722	4-1/2
FC1723	4-3/4
FC1724	5
FC1725	5-1/4
FC1726	5-1/2
FC1727	5-3/4
FC1728	6

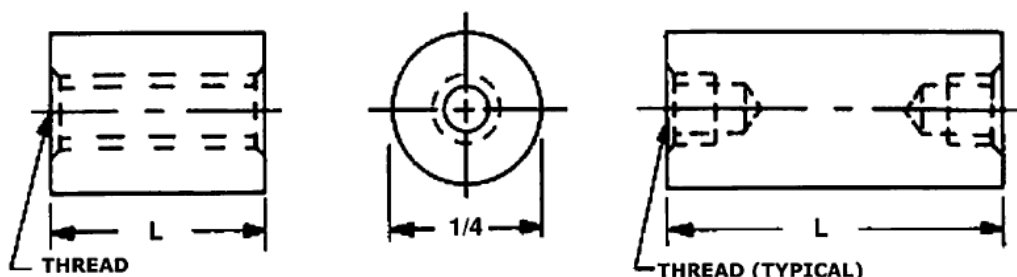

- Contact Sales Office for sizes not shown
- Source Control Drawing: To be produced by Fascomp Electronic Hardware

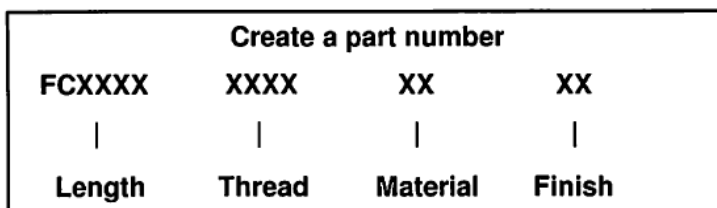

Thread			
Thread Code (XXX)	Tapped Thru		Longer Parts
	A, B, S	SS	Blind Tap Depth
440	1	3/4	1/4
632	1	1	3/8
832	1	1	7/16
1032	1-1/8	1	1/2

Aluminum (A), Brass (B), Steel (S), Stainless Steel (SS)

Material	
Material Code (XX)	
A	Aluminum
B	Brass
S	Steel
SS	Stainless Steel
N	Nylon

See page 3 for finish codes



Fascomp Electronic Hardware
 7814 Kingspointe Pkwy
 Orlando, FL 32819
 www.fascomp.com
 Tel: (407) 226-2
 Fax: (407) 226-3

Angic Global Solutions 1-888-872-0690
<https://www.AngicGlobal.com> Sales@AngicGlobal.com



5/16 Round Female Standoff

FCXXXX	Length (L)
FC1745	1/8
FC1746	3/16
FC1747	1/4
FC1748	5/16
FC1749	3/8
FC1750	7/16
FC1751	1/2
FC1752	9/16
FC1753	5/8
FC1754	11/16
FC1755	3/4
FC1756	13/16
FC1757	7/8
FC1758	15/16
FC1759	1
FC1760	1-1/16
FC1761	1-1/8
FC1762	1-3/16
FC1763	1-1/4
FC1764	1-5/16
FC1765	1-3/8
FC1766	1-7/16
FC1767	1-1/2
FC1768	1-9/16
FC1769	1-5/8
FC1770	1-11/16
FC1771	1-3/4
FC1772	1-13/16
FC1773	1-7/8
FC1774	1-15/16
FC1775	2
FC1776	2-1/8
FC1777	2-1/4
FC1778	2-3/8
FC1779	2-1/2
FC1780	2-5/8
FC1781	2-3/4
FC1782	2-7/8
FC1783	3
FC1784	3-1/4
FC1785	3-1/2
FC1786	3-3/4
FC1787	4
FC1788	4-1/4
FC1789	4-1/2
FC1790	4-3/4
FC1791	5
FC1792	5-1/4
FC1793	5-1/2
FC1794	5-3/4
FC1795	

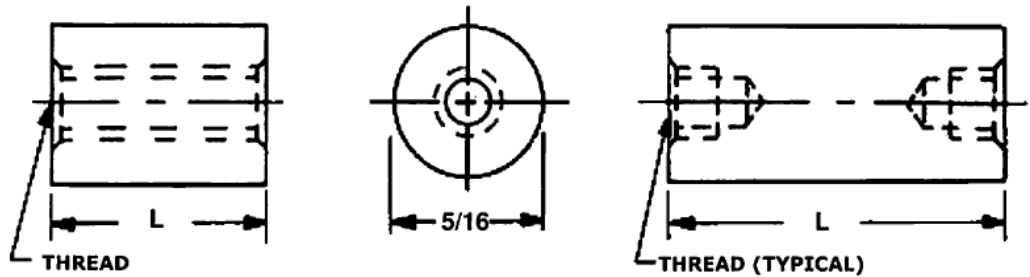

- Contact Sales Office for sizes not shown
- Source Control Drawing: To be produced by Fascomp Electronic Hardware

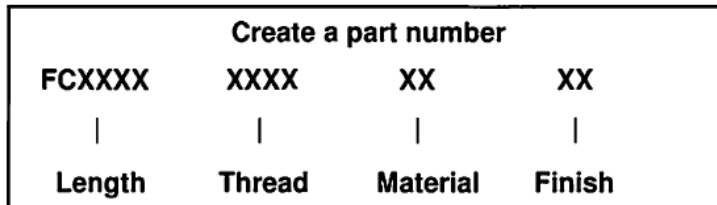

Thread			
Thread Code (XXX)	Tapped Thru		Longer Parts
	A, B, S	SS	Blind Tap Depth
440	1	3/4	1/4
632	1	1	3/8
832	1	1	7/16
1032	1-1/8	1	1/2

Aluminum (A), Brass (B), Steel (S), Stainless Steel (SS)

Material	
Material Code (XX)	
A	Aluminum
B	Brass
S	Steel
SS	Stainless Steel
N	Nylon

See page 3 for finish codes



Fascomp Electronic Hardware
 7814 Kingspointe Pkwy
 Orlando, FL 32819
 www.fascomp.com
 Tel: (407) 226-21
 Fax: (407) 226-3:



Get quote »

Angic Global Solutions 1-888-872-0690
<https://www.AngicGlobal.com> Sales@AngicGlobal.com

3/8 Round Female Standoff

FCXXXX	Length (L)
FC1812	1/8
FC1813	3/16
FC1814	1/4
FC1815	5/16
FC1816	3/8
FC1817	7/16
FC1818	1/2
FC1819	9/16
FC1820	5/8
FC1821	11/16
FC1822	3/4
FC1823	13/16
FC1824	7/8
FC1825	15/16
FC1826	1
FC1827	1-1/16
FC1828	1-1/8
FC1829	1-3/16
FC1830	1-1/4
FC1831	1-5/16
FC1832	1-3/8
FC1833	1-7/16
FC1834	1-1/2
FC1835	1-9/16
FC1836	1-5/8
FC1837	1-11/16
FC1838	1-3/4
FC1839	1-13/16
FC1840	1-7/8
FC1841	1-15/16
FC1842	2
FC1843	2-1/8
FC1844	2-1/4
FC1845	2-3/8
FC1846	2-1/2
FC1847	2-5/8
FC1848	2-3/4
FC1849	2-7/8
FC1850	3
FC1851	3-1/4
FC1852	3-1/2
FC1853	3-3/4
FC1854	4
FC1855	4-1/4
FC1856	4-1/2
FC1857	4-3/4
FC1858	5
FC1859	5-1/4
FC1860	5-1/2
FC1861	5-3/4
FC1862	6

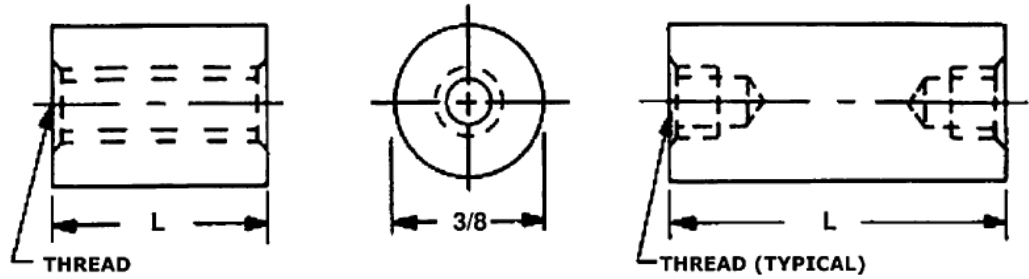

- Contact Sales Office for sizes not shown
- Source Control Drawing: To be produced by Fascomp Electronic Hardware

Create a part number

FCXXXX	XXXX	XX	XX
Length	Thread	Material	Finish

Thread			
Thread Code (XXX)	Tapped Thru		Longer Parts
	A, B, S	SS	Blind Tap Depth
632	1	1	3/8
832	1	1	7/16
1032	1-1/8	1	1/2
1224	1-1/8	1	1/2
2520	1-1/4	1/1-4	5/8

Aluminum (A), Brass (B), Steel (S), Stainless Steel (SS)

Material	
Material Code (XX)	
A	Aluminum
B	Brass
S	Steel
SS	Stainless Steel
N	Nylon

See page 3 for finish codes



Fascomp Electronic Hardware
 7814 Kingspointe Pkwy
 Orlando, FL 32819
 www.fascomp.com
 Tel: (407) 226-
 Fax: (407) 226-



1/2 Round Female Standoff

FCXXXX	Length (L)
FC1879	1/8
FC1880	3/16
FC1881	1/4
FC1882	5/16
FC1883	3/8
FC1884	7/16
FC1885	1/2
FC1886	9/16
FC1887	5/8
FC1888	11/16
FC1889	3/4
FC1890	13/16
FC1891	7/8
FC1892	15/16
FC1893	1
FC1894	1-1/16
FC1895	1-1/8
FC1896	1-3/16
FC1897	1-1/4
FC1898	1-5/16
FC1899	1-3/8
FC1900	1-7/16
FC1901	1-1/2
FC1902	1-9/16
FC1903	1-5/8
FC1904	1-11/16
FC1905	1-3/4
FC1906	1-13/16
FC1907	1-7/8
FC1908	1-15/16
FC1909	2
FC1910	2-1/8
FC1911	2-1/4
FC1912	2-3/8
FC1913	2-1/2
FC1914	2-5/8
FC1915	2-3/4
FC1916	2-7/8
FC1917	3
FC1918	3-1/4
FC1919	3-1/2
FC1920	3-3/4
FC1921	4
FC1922	4-1/4
FC1923	4-1/2
FC1924	4-3/4
FC1925	5
FC1926	5-1/4
FC1927	5-1/2
FC1928	5-3/4
FC1929	

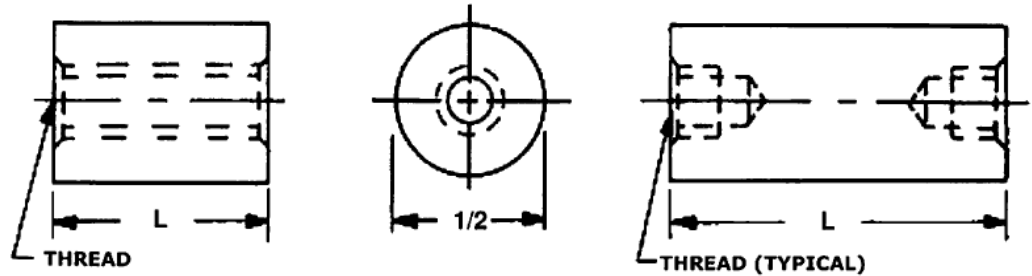

- Contact Sales Office for sizes not shown
- Source Control Drawing: To be produced by Fascomp Electronic Hardware

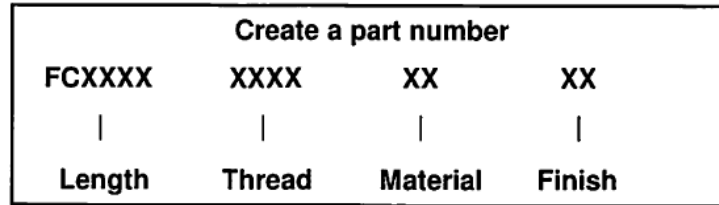

Thread			
Thread Code (XXX)	Tapped Thru		Longer Parts
	A, B, S	SS	Blind Tap Depth
632	1	1	3/8
832	1	1	7/16
1032	1-1/8	1	1/2
1224	1-1/8	1	1/2
2520	1-1/4	1-1/4	5/8

Aluminum (A), Brass (B), Steel (S), Stainless Steel (SS)

Material	
Material Code (XX)	
A	Aluminum
B	Brass
S	Steel
SS	Stainless Steel
N	Nylon

See page 3 for finish codes



Fascomp Electronic Hardware
 7814 Kingspointe Pkwy
 Orlando, FL 32819
 www.fascomp.com
 Tel: (407) 226-2117
 Fax: (407) 226-3374



Get quote >>

Angic Global Solutions

1-888-872-0690

<https://www.AngicGlobal.com> Sales@AngicGlobal.com

5/8 Round Female Standoff

FCXXXX	Length (L)
FC1946	1/8
FC1947	3/16
FC1948	1/4
FC1949	5/16
FC1950	3/8
FC1951	7/16
FC1952	1/2
FC1953	9/16
FC1954	5/8
FC1955	11/16
FC1956	3/4
FC1957	13/16
FC1958	7/8
FC1959	15/16
FC1960	1
FC1961	1-1/16
FC1962	1-1/8
FC1963	1-3/16
FC1964	1-1/4
FC1965	1-5/16
FC1966	1-3/8
FC1967	1-7/16
FC1968	1-1/2
FC1969	1-9/16
FC1990	1-5/8
FC1971	1-11/16
FC1972	1-3/4
FC1973	1-13/16
FC1974	1-7/8
FC1975	1-15/16
FC1976	2
FC1977	2-1/8
FC1978	2-1/4
FC1979	2-3/8
FC1980	2-1/2
FC1981	2-5/8
FC1982	2-3/4
FC1983	2-7/8
FC1984	3
FC1985	3-1/4
FC1986	3-1/2
FC1987	3-3/4
FC1988	4
FC1989	4-1/4
FC1990	4-1/2
FC1991	4-3/4
FC1992	5
FC1993	5-1/4
FC1994	5-1/2
FC1995	5-3/4
FC1996	6

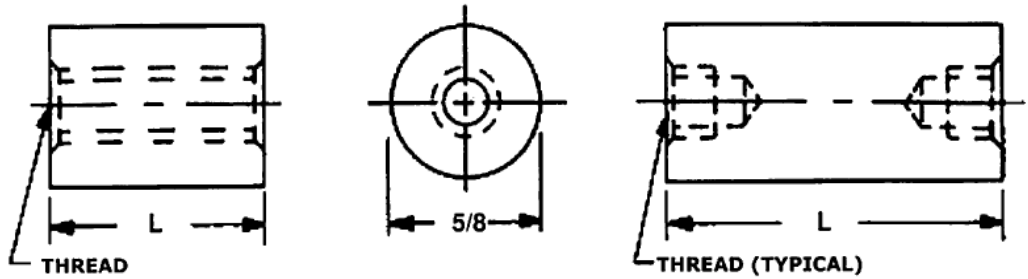

- Contact Sales Office for sizes not shown
- Source Control Drawing: To be produced by Fascomp Electronic Hardware

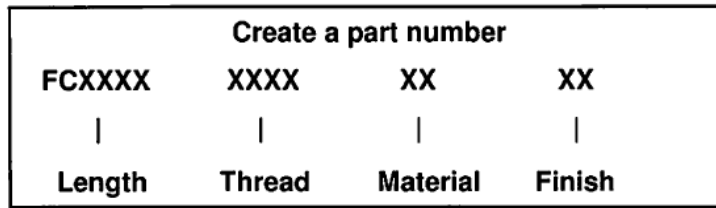

Thread			
Thread Code (XXX)	Tapped Thru		Longer Parts
	A, B, S	SS	Blind Tap Depth
832	1	1	7/16
1032	1-1/8	1	1/2
1224	1-1/8	1	1/2
2520	1-1/4	1-1/4	5/8

Aluminum (A), Brass (B), Steel (S), Stainless Steel (SS)

Material	
Material Code (XX)	
A	Aluminum
B	Brass
S	Steel
SS	Stainless Steel
N	Nylon

See page 3 for finish codes



Fascomp Electronic Hardware
 7814 Kingspointe Pkwy
 Orlando, FL 32819
 www.fascomp.com
 Tel: (407) 221-1111
 Fax: (407) 221-1112

Angic Global Solutions

1-888-872-0690

<https://www.AngicGlobal.com> Sales@AngicGlobal.com



1/8 Hex Female Standoff

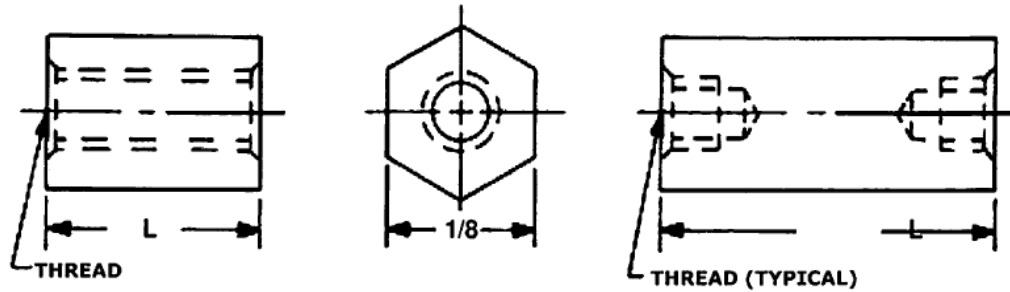

- Contact Sales Office for sizes not shown
- Source Control Drawing: To be produced by Fascomp Electronic Hardware

FCXXXX	Length (L)
FC2020	1/8
FC2021	3/16
FC2022	1/4
FC2023	5/16
FC2024	3/8
FC2025	7/16
FC2026	1/2
FC2027	9/16
FC2028	5/8
FC2029	11/16
FC2030	3/4
FC2031	13/16
FC2032	7/8
FC2033	15/16
FC2034	1
FC2035	1-1/16
FC2036	1-1/8
FC2037	1-3/16
FC2038	1-1/4
FC2039	1-5/16
FC2040	1-3/8
FC2041	1-7/16
FC2142	1-1/2
FC2143	1-9/16
FC2144	1-5/8
FC2145	1-11/16
FC2146	1-3/4
FC2147	1-13/16
FC2148	1-7/8
FC2149	1-15/16
FC2150	2

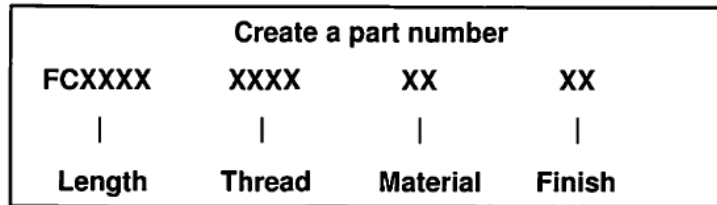

Thread			
Thread Code (XXX)	Tapped Thru		Longer Parts
	A, B, S	SS	Blind Tap Depth
080	3/8	1/4	3/16
256	3/4	5/8	3/16

Aluminum (A), Brass (B), Steel (S), Stainless Steel (SS)

Material	
Material Code (XX)	
A	Aluminum
B	Brass
S	Steel
SS	Stainless Steel
N	Nylon

See page 3 for finish codes



Fascomp Electronic Hardware
 7814 Kingspointe Pkwy
 Orlando, FL 32819
 www.fascomp.com
 Tel: (407) 226-2
 Fax: (407) 226-3



Get quote »

Angic Global Solutions

1-888-872-0690

<https://www.AngicGlobal.com> Sales@AngicGlobal.com

3/16 Hex Female Standoff

FCXXX	Length (L)
FC2051	1/8
FC2052	3/16
FC2053	1/4
FC2054	5/16
FC2055	3/8
FC2056	7/16
FC2057	1/2
FC2058	9/16
FC2059	5/8
FC2060	11/16
FC2061	3/4
FC2062	13/16
FC2063	7/8
FC2064	15/16
FC2065	1
FC2066	1-1/16
FC2067	1-1/8
FC2068	1-3/16
FC2069	1-1/4
FC2070	1-5/16
FC2071	1-3/8
FC2072	1-7/16
FC2073	1-1/2
FC2074	1-9/16
FC2075	1-5/8
FC2076	1-11/16
FC2077	1-3/4
FC2078	1-13/16
FC2079	1-7/8
FC2080	1-15/16
FC2081	2
FC2082	2-1/16
FC2083	2-1/8
FC2084	2-3/16
FC2085	2-1/4
FC2086	2-5/16
FC2087	2-3/8
FC2088	2-7/16
FC2089	2-1/2
FC2090	2-9/16
FC2091	2-5/8
FC2092	2-11/16
FC2093	2-3/4
FC2094	2-13/16
FC2095	2-7/8
FC2096	2-15/16
FC2097	3

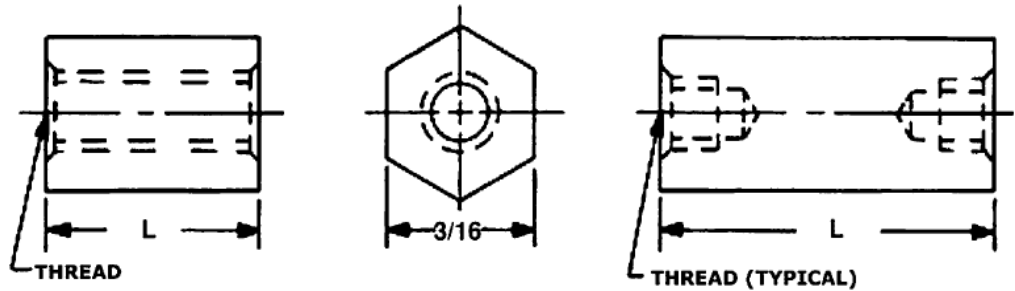

- Contact Sales Office for sizes not shown
- Source Control Drawing: To be produced by Fascomp Electronic Hardware

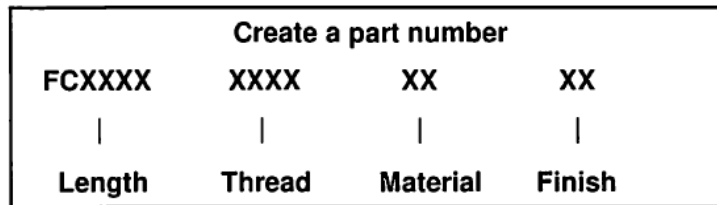

Thread			
Thread Code (XXX)	Tapped Thru		Longer Parts
	A, B, S	SS	Blind Tap Depth
256	3/4	5/8	3/16
440	1	3/4	1/4

Aluminum (A), Brass (B), Steel (S), Stainless Steel (SS)

Material	
Material Code (XX)	
A	Aluminum
B	Brass
S	Steel
SS	Stainless Steel
N	Nylon

See page 3 for finish codes



Fascomp Electronic Hardware
 7814 Kingspointe Pkwy
 Orlando, FL 32819
 www.fascomp.com
 Tel: (407) 226-21
 Fax: (407) 226-33



1/4 Hex Female Standoff

FCXXXX	Length (L)
FC2098	1/8
FC2099	3/16
FC2100	1/4
FC2101	5/16
FC2102	3/8
FC2103	7/16
FC2104	1/2
FC2105	9/16
FC2106	5/8
FC2107	11/16
FC2108	3/4
FC2109	13/16
FC2110	7/8
FC2111	15/16
FC2112	1
FC2113	1-1/16
FC2114	1-1/8
FC2115	1-3/16
FC2116	1-1/4
FC2117	1-5/16
FC2118	1-3/8
FC2119	1-7/16
FC2120	1-1/2
FC2121	1-9/16
FC2122	1-5/8
FC2123	1-11/16
FC2124	1-3/4
FC2125	1-13/16
FC2126	1-7/8
FC2127	1-15/16
FC2128	2
FC2129	2-1/8
FC2130	2-1/4
FC2131	2-3/8
FC2132	2-1/2
FC2133	2-5/8
FC2134	2-3/4
FC2135	2-7/8
FC2136	3
FC2137	3-1/4
FC2138	3-1/2
FC2139	3-3/4
FC2140	4
FC2141	4-1/4
FC2142	4-1/2
FC2143	4-3/4
FC2144	5
FC2145	5-1/4
FC2146	5-1/2
FC2147	5-3/4
FC2148	6

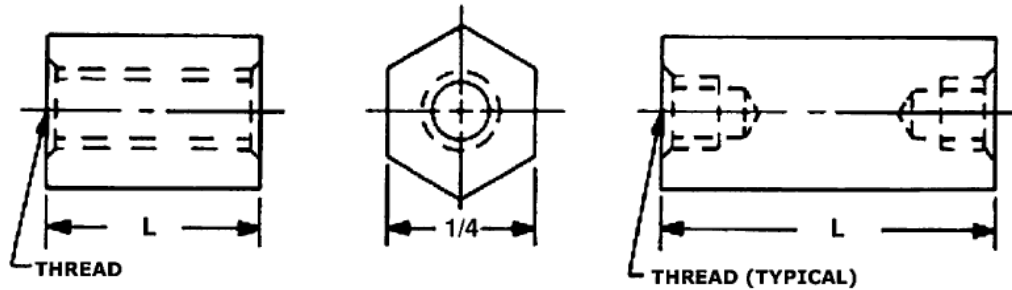

- Contact Sales Office for sizes not shown
- Source Control Drawing: To be produced by Fascomp Electronic Hardware

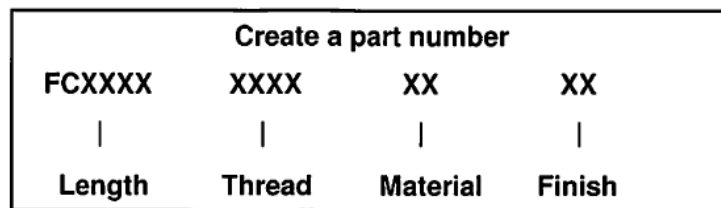

Thread			
Thread Code (XXX)	Tapped Thru		Longer Parts
	A, B, S	SS	Blind Tap Depth
440	1	3/4	1/4
632	1	1	3/8
832	1	1	7/16
1032	1-1/8	1	1/2

Aluminum (A), Brass (B), Steel (S), Stainless Steel (SS)

Material	
Material Code (XX)	
A	Aluminum
B	Brass
S	Steel
SS	Stainless Steel
N	Nylon

See page 3 for finish codes



Fascomp Electronic Hardware
 7814 Kingspointe Pkwy
 Orlando, FL 32819
 www.fascomp.com
 Tel: (407) 226-2
 Fax: (407) 226-3



Get quote >>

Angic Global Solutions

1-888-872-0690

<https://www.AngicGlobal.com> Sales@AngicGlobal.com

5/16 Hex Female Standoff

FCXXX	Length (L)
FC2165	1/8
FC2166	3/16
FC2167	1/4
FC2168	5/16
FC2169	3/8
FC2170	7/16
FC2171	1/2
FC2172	9/16
FC2173	5/8
FC2174	11/16
FC2175	3/4
FC2176	13/16
FC2177	7/8
FC2178	15/16
FC2179	1
FC2180	1-1/16
FC2181	1-1/8
FC2182	1-3/16
FC2183	1-1/4
FC2184	1-5/16
FC2185	1-3/8
FC2186	1-7/16
FC2187	1-1/2
FC2188	1-9/16
FC2189	1-5/8
FC2190	1-11/16
FC2191	1-3/4
FC2192	1-13/16
FC2193	1-7/8
FC2194	1-15/16
FC2195	2
FC2196	2-1/8
FC2197	2-1/4
FC2198	2-3/8
FC2199	2-1/2
FC2200	2-5/8
FC2201	2-3/4
FC2202	2-7/8
FC2203	3
FC2204	3-1/4
FC2205	3-1/2
FC2206	3-3/4
FC2207	4
FC2208	4-1/4
FC2209	4-1/2
FC2210	4-3/4
FC2211	5
FC2212	5-1/4
FC2213	5-1/2
FC2214	5-3/4
FC2215	6

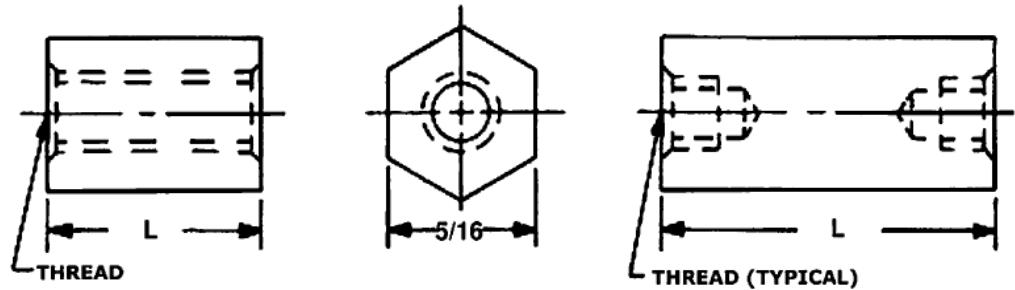

- Contact Sales Office for sizes not shown
- Source Control Drawing: To be produced by Fascomp Electronic Hardware

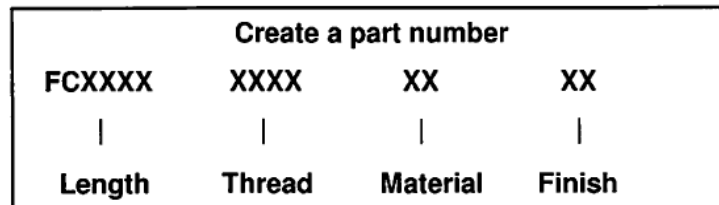

Thread			
Thread Code (XXX)	Tapped Thru		Longer Parts
	A, B, S	SS	Blind Tap Depth
440	1	3/4	1/4
632	1	1	3/8
832	1	1	7/16
1032	1-1/8	1	1/2

Aluminum (A), Brass (B), Steel (S), Stainless Steel (SS)

Material	
Material Code (XX)	
A	Aluminum
B	Brass
S	Steel
SS	Stainless Steel
N	Nylon

See page 3 for finish codes



Fascomp Electronic Hardware
 7814 Kingspointe Pkwy
 Orlando, FL 32819
 www.fascomp.com
 Tel: (407) 226-21
 Fax: (407) 226-33

3/8 Hex Female Standoff

FCXXXX	Length (L)
FC2232	1/8
FC2233	3/16
FC2234	1/4
FC2235	5/16
FC2236	3/8
FC2237	7/16
FC2238	1/2
FC2239	9/16
FC2240	5/8
FC2241	11/16
FC2242	3/4
FC2243	13/16
FC2244	7/8
FC2245	15/16
FC2246	1
FC2247	1-1/16
FC2248	1-1/8
FC2249	1-3/16
FC2250	1-1/4
FC2251	1-5/16
FC2252	1-3/8
FC2253	1-7/16
FC2254	1-1/2
FC2255	1-9/16
FC2256	1-5/8
FC2257	1-11/16
FC2258	1-3/4
FC2259	1-13/16
FC2260	1-7/8
FC2261	1-15/16
FC2262	2
FC2263	2-1/8
FC2264	2-1/4
FC2265	2-3/8
FC2266	2-1/2
FC2267	2-5/8
FC2268	2-3/4
FC2269	2-7/8
FC2270	3
FC2271	3-1/4
FC2272	3-1/2
FC2273	3-3/4
FC2274	4
FC2275	4-1/4
FC2276	4-1/2
FC2277	4-3/4
FC2278	5
FC2279	5-1/4
FC2280	5-1/2
FC2281	5-3/4
FC2282	6

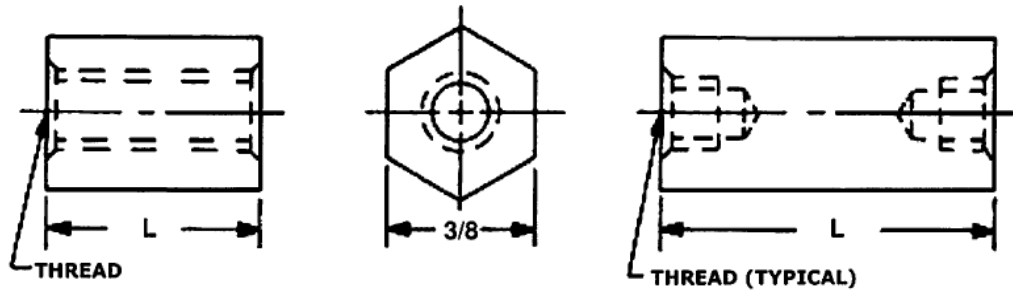

- Contact Sales Office for sizes not shown
- Source Control Drawing: To be produced by Fascomp Electronic Hardware

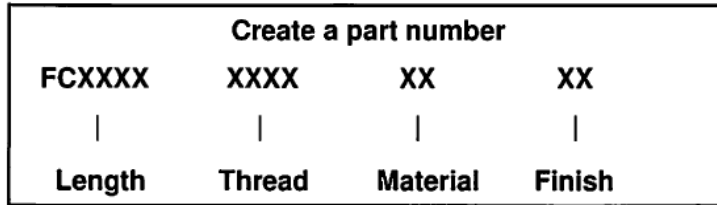

Thread			
Thread Code (XXX)	Tapped Thru		Longer Parts
	A, B, S	SS	Blind Tap Depth
632	1	1	3/8
832	1	1	7/16
1032	1-1/8	1	1/2
1224	1-1/8	1	1/2
2520	1-1/4	1/1-4	5/8

Material	
Material Code (XX)	
A	Aluminum
B	Brass
S	Steel
SS	Stainless Steel
N	Nylon

See page 3 for finish codes

Aluminum (A), Brass (B), Steel (S), Stainless Steel (SS)



Fascomp Electronic Hardware
 7814 Kingspointe Pkwy
 Orlando, FL 32819
 www.fascomp.com
 Tel: (407) 226-2111
 Fax: (407) 226-3377



Get quote >>

Angic Global Solutions

1-888-872-0690

<https://www.AngicGlobal.com> Sales@AngicGlobal.com

1/2 Hex Female Standoff

FCXXXX	Length (L)
FC2999	1/8
FC2300	3/16
FC2301	1/4
FC2302	5/16
FC2303	3/8
FC2304	7/16
FC2305	1/2
FC2306	9/16
FC2307	5/8
FC2308	11/16
FC2309	3/4
FC2310	13/16
FC2311	7/8
FC2312	15/16
FC2313	1
FC2314	1-1/16
FC2315	1-1/8
FC2316	1-3/16
FC2317	1-1/4
FC2318	1-5/16
FC2319	1-3/8
FC2320	1-7/16
FC2321	1-1/2
FC2322	1-9/16
FC2323	1-5/8
FC2324	1-11/16
FC2325	1-3/4
FC2326	1-13/16
FC2327	1-7/8
FC2328	1-15/16
FC2329	2
FC2330	2-1/8
FC2331	2-1/4
FC2332	2-3/8
FC2333	2-1/2
FC2334	2-5/8
FC2335	2-3/4
FC2336	2-7/8
FC2337	3
FC2338	3-1/4
FC2339	3-1/2
FC2340	3-3/4
FC2341	4
FC2342	4-1/4
FC2343	4-1/2
FC2344	4-3/4
FC2345	5
FC2346	5-1/4
FC2347	5-1/2
FC2348	5-3/4
FC2349	6

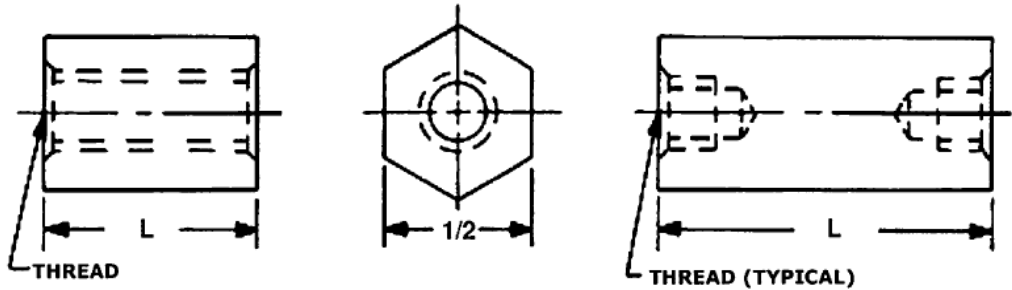

- Contact Sales Office for sizes not shown
- Source Control Drawing: To be produced by Fascomp Electronic Hardware

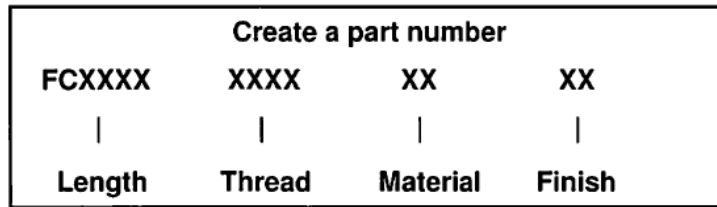

Thread			
Thread Code (XXX)	Tapped Thru		Longer Parts
	A, B, S	SS	Blind Tap Depth
632	1	1	3/8
832	1	1	7/16
1032	1-1/8	1	1/2
1224	1-1/8	1	1/2
2520	1-1/4	1-1/4	5/8

Aluminum (A), Brass (B), Steel (S), Stainless Steel (SS)

Material	
Material Code (XX)	
A	Aluminum
B	Brass
S	Steel
SS	Stainless Steel
N	Nylon

See page 3 for finish codes



Fascomp Electronic Hardware
 7814 Kingspointe Pkwy
 Orlando, FL 32819
 www.fascomp.com
 Tel: (407) 226-2112
 Fax: (407) 226-3370



5/8 Hex Female Standoff

FCXXXX	Length (L)
FC2366	1/8
FC2367	3/16
FC2368	1/4
FC2369	5/16
FC2370	3/8
FC2371	7/16
FC2372	1/2
FC2373	9/16
FC2374	5/8
FC2375	11/16
FC2376	3/4
FC2377	13/16
FC2378	7/8
FC2379	15/16
FC2380	1
FC2381	1-1/16
FC2382	1-1/8
FC2383	1-3/16
FC2384	1-1/4
FC2385	1-5/16
FC2386	1-3/8
FC2387	1-7/16
FC2388	1-1/2
FC2389	1-9/16
FC2390	1-5/8
FC2391	1-11/16
FC2392	1-3/4
FC2393	1-13/16
FC2394	1-7/8
FC2395	1-15/16
FC2396	2
FC2397	2-1/8
FC2398	2-1/4
FC2399	2-3/8
FC2400	2-1/2
FC2401	2-5/8
FC2402	2-3/4
FC2403	2-7/8
FC2404	3
FC2405	3-1/4
FC2406	3-1/2
FC2407	3-3/4
FC2408	4
FC2409	4-1/4
FC2410	4-1/2
FC2411	4-3/4
FC2412	5
FC2413	5-1/4
FC2414	5-1/2
FC2415	5-3/4
FC2416	

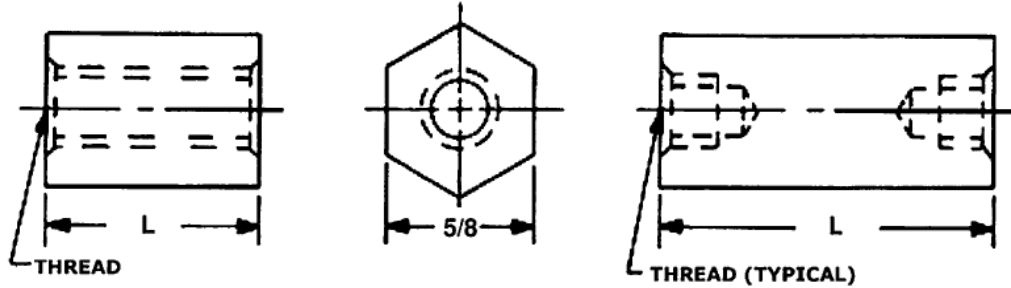

- Contact Sales Office for sizes not shown
- Source Control Drawing: To be produced by Fascomp Electronic Hardware

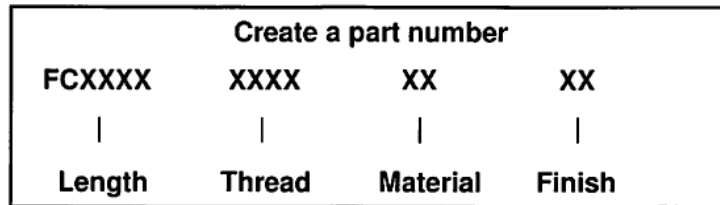

Thread			
Thread Code (XXX)	Tapped Thru		Longer Parts
	A, B, S	SS	Blind Tap Depth
832	1	1	7/16
1032	1-1/8	1	1/2
1224	1-1/8	1	1/2
2520	1-1/4	1-1/4	5/8

Aluminum (A), Brass (B), Steel (S), Stainless Steel (SS)

Material	
Material Code (XX)	
A	Aluminum
B	Brass
S	Steel
SS	Stainless Steel
N	Nylon

See page 3 for finish codes



Fascomp Electronic Hardware
 7814 Kingspointe Pkwy
 Orlando, FL 32819
 www.fascomp.com
 tel: (407) 226-2111
 fax: (407) 226-3377



Get quote >>

Angic Global Solutions

1-888-872-0690

<https://www.AngicGlobal.com> Sales@AngicGlobal.com



Square Female Standoffs

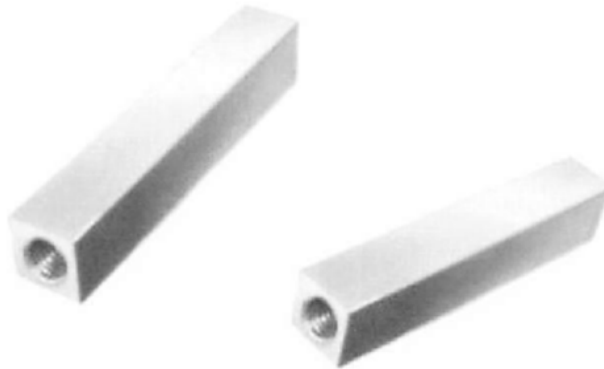

Fascomp stocks Square Female Standoffs in aluminum, brass, steel, stainless steel and nylon.

	Page No.
1/8	101
3/16	102
1/4	103
5/16	104
3/8	105
1/2	106
5/8	107



Fascomp Electronic Hardware
7814 Kingspointe Pkwy
Orlando, FL 32819
www.fascomp.com
Tel: (407) 226-2112
Fax: (407) 226-3370



1/8 Square Female Standoff

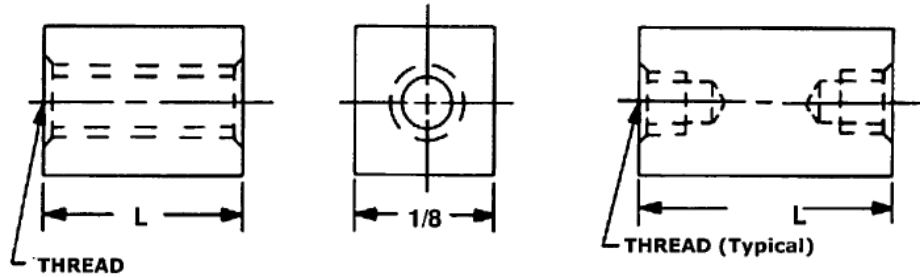

- Contact Sales Office for sizes not shown
- Source Control Drawing: To be produced by Fascomp Electronic Hardware

FCXXXX	Length (L)
FC2450	1/8
FC2451	3/16
FC2452	1/4
FC2453	5/16
FC2454	3/8
FC2455	7/16
FC2456	1/2
FC2457	9/16
FC2458	5/8
FC2459	11/16
FC2460	3/4
FC2461	13/16
FC2462	7/8
FC2463	15/16
FC2464	1
FC2465	1-1/16
FC2466	1-1/8
FC2467	1-3/16
FC2468	1-1/4
FC2469	1-5/16
FC2470	1-3/8
FC2471	1-7/16
FC2472	1-1/2
FC2473	1-9/16
FC2474	1-5/8
FC2475	1-11/16
FC2476	1-3/4
FC2477	1-13/16
FC2478	1-7/8
FC2479	1-15/16
FC2480	2

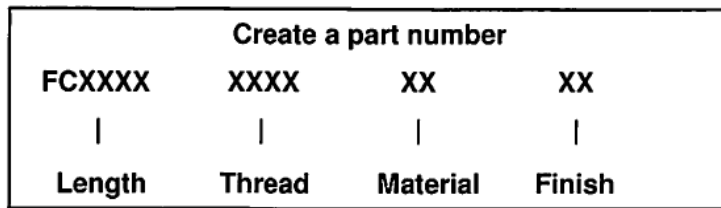

Thread			
Thread Code (XXX)	Tapped Thru		Longer Parts
	A, B, S	SS	Blind Tap Depth
080	3/8	1/4	3/16
256	3/4	5/8	3/16

Aluminum (A), Brass (B), Steel (S), Stainless Steel (SS)

Material	
Material Code (XX)	
A	Aluminum
B	Brass
S	Steel
SS	Stainless Steel
N	Nylon

See page 3 for finish codes



Fascomp Electronic Hardware
 7814 Kingspointe Pkwy
 Orlando, FL 32819
 www.fascomp.com
 Tel: (407) 226-2112
 (407) 226-3370



Get quote »

Angic Global Solutions

1-888-872-0690

<https://www.AngicGlobal.com> Sales@AngicGlobal.com

3/16 Square Female Standoff

FCXXX	Length (L)
FC2481	1/8
FC2482	3/16
FC2483	1/4
FC2484	5/16
FC2485	3/8
FC2486	7/16
FC2487	1/2
FC2488	9/16
FC2489	5/8
FC2490	11/16
FC2491	3/4
FC2492	13/16
FC2493	7/8
FC2494	15/16
FC2495	1
FC2496	1-1/16
FC2497	1-1/8
FC2498	1-3/16
FC2499	1-1/4
FC2500	1-5/16
FC2501	1-3/8
FC2502	1-7/16
FC2503	1-1/2
FC2504	1-9/16
FC2505	1-5/8
FC2506	1-11/16
FC2507	1-3/4
FC2508	1-13/16
FC2509	1-7/8
FC2510	1-15/16
FC2511	2
FC2512	2-1/16
FC2513	2-1/8
FC2514	2-3/16
FC2515	2-1/4
FC2516	2-5/16
FC2517	2-3/8
FC2518	2-7/16
FC2519	2-1/2
FC2520	2-9/16
FC2521	2-5/8
FC2522	2-11/16
FC2523	2-3/4
FC2524	2-13/16
FC2525	2-7/8
FC2526	2-15/16
FC2527	3

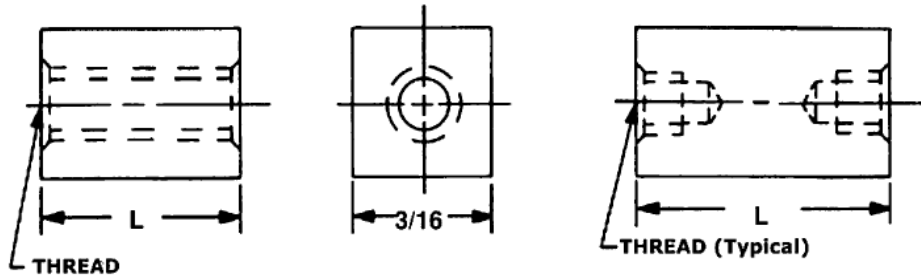

- Contact Sales Office for sizes not shown
- Source Control Drawing: To be produced by Fascomp Electronic Hardware

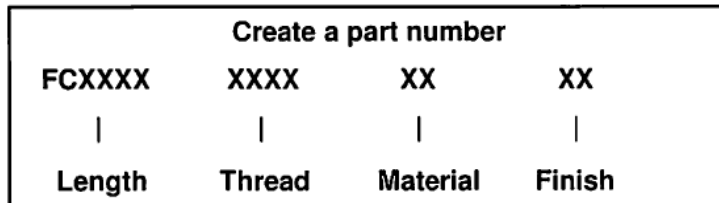

Thread			
Thread Code (XXX)	Tapped Thru		Longer Parts
	A, B, S	SS	Blind Tap Depth
256	3/4	5/8	3/16
440	1	3/4	1/4

Aluminum (A), Brass (B), Steel (S), Stainless Steel (SS)

Material	
Material Code (XX)	
A	Aluminum
B	Brass
S	Steel
SS	Stainless Steel
N	Nylon

See page 3 for finish codes



Fascomp Electronic Hardware
 7814 Kingspointe Pkwy
 Orlando, FL 32819
 www.fascomp.com
 Tel: (407) 226-2112
 Fax: (407) 226-3



1/4 Square Female Standoff

FCXXXX	Length (L)
FC2528	1/8
FC2529	3/16
FC2530	1/4
FC2531	5/16
FC2532	3/8
FC2533	7/16
FC2534	1/2
FC2535	9/16
FC2536	5/8
FC2537	11/16
FC2538	3/4
FC2539	13/16
FC2540	7/8
FC2541	15/16
FC2542	1
FC2543	1-1/16
FC2544	1-1/8
FC2545	1-3/16
FC2546	1-1/4
FC2547	1-5/16
FC2548	1-3/8
FC2549	1-7/16
FC2550	1-1/2
FC2551	1-9/16
FC2552	1-5/8
FC2553	1-11/16
FC2554	1-3/4
FC2555	1-13/16
FC2556	1-7/8
FC2557	1-15/16
FC2558	2
FC2559	2-1/8
FC2560	2-1/4
FC2561	2-3/8
FC2562	2-1/2
FC2563	2-5/8
FC2564	2-3/4
FC2565	2-7/8
FC2566	3
FC2567	3-1/4
FC2568	3-1/2
FC2569	3-3/4
FC2570	4
FC2571	4-1/4
FC2572	4-1/2
FC2573	4-3/4
FC2574	5
FC2575	5-1/4
FC2576	5-1/2
FC2577	5-3/4
FC2578	6

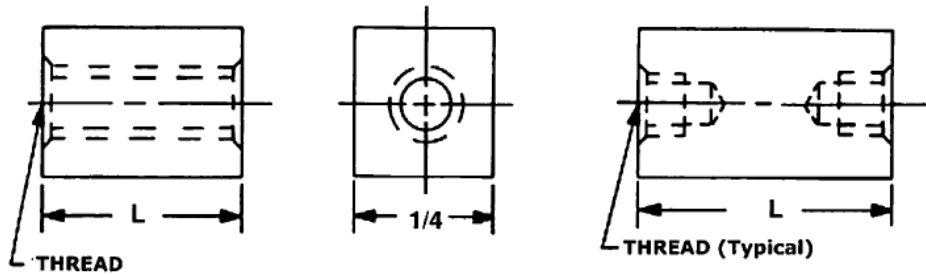

- Contact Sales Office for sizes not shown
- Source Control Drawing: To be produced by Fascomp Electronic Hardware

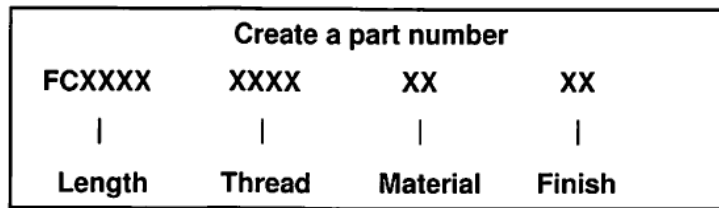

Thread			
Thread Code (XXX)	Tapped Thru		Longer Parts
	A, B, S	SS	Blind Tap Depth
440	1	3/4	1/4
632	1	1	3/8
832	1	1	7/16
1032	1-1/8	1	1/2

Aluminum (A), Brass (B), Steel (S), Stainless Steel (SS)

Material	
Material Code (XX)	
A	Aluminum
B	Brass
S	Steel
SS	Stainless Steel
N	Nylon

See page 3 for finish codes



Fascomp Electronic Hardware
 7814 Kingspointe Pkwy
 Orlando, FL 32819
 www.fascomp.com
 Tel: (407) 226-2112
 Fax: (407) 226-3371



Get quote >>

Angic Global Solutions

1-888-872-0690

<https://www.AngicGlobal.com> Sales@AngicGlobal.com

5/16 Square Female Standoff

FCXXXX	Length (L)
FC2595	1/8
FC2596	3/16
FC2597	1/4
FC2598	5/16
FC2599	3/8
FC2600	7/16
FC2601	1/2
FC2602	9/16
FC2603	5/8
FC2604	11/16
FC2605	3/4
FC2606	13/16
FC2607	7/8
FC2608	15/16
FC2609	1
FC2610	1-1/16
FC2611	1-1/8
FC2612	1-3/16
FC2613	1-1/4
FC2614	1-5/16
FC2615	1-3/8
FC2616	1-7/16
FC2617	1-1/2
FC2618	1-9/16
FC2619	1-5/8
FC2620	1-11/16
FC2621	1-3/4
FC2622	1-13/16
FC2623	1-7/8
FC2624	1-15/16
FC2625	2
FC2626	2-1/8
FC2627	2-1/4
FC2628	2-3/8
FC2629	2-1/2
FC2630	2-5/8
FC2631	2-3/4
FC2632	2-7/8
FC2633	3
FC2634	3-1/4
FC2635	3-1/2
FC2636	3-3/4
FC2637	4
FC2638	4-1/4
FC2639	4-1/2
FC2640	4-3/4
FC2641	5
FC2642	5-1/4
FC2643	5-1/2
FC2644	5-3/4
FC2645	6

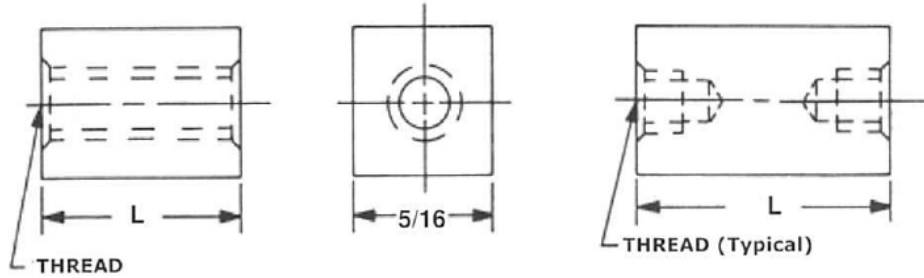

- Contact Sales Office for sizes not shown
- Source Control Drawing: To be produced by Fascomp Electronic Hardware

Create a part number			
FCXXXX	XXXX	XX	XX
Length	Thread	Material	Finish

Thread			
Thread Code (XXX)	Tapped Thru		Longer Parts
	A, B, S	SS	Blind Tap Depth
440	1	3/4	1/4
632	1	1	3/8
832	1	1	7/16
1032	1-1/8	1	1/2

Aluminum (A), Brass (B), Steel (S), Stainless Steel (SS)

Material	
Material Code (XX)	
A	Aluminum
B	Brass
S	Steel
SS	Stainless Steel
N	Nylon

See page 3 for finish codes



Fascomp Electronic Hardware
7814 Kingspointe Pkwy
Orlando, FL 32819
www.fascomp.com
Tel: (407) 226-2112
Fax: (407) 226-3370

3/8 Square Female Standoff

FCXXXX	Length (L)
FC2662	1/8
FC2663	3/16
FC2664	1/4
FC2665	5/16
FC2666	3/8
FC2667	7/16
FC2668	1/2
FC2669	9/16
FC2670	5/8
FC2671	11/16
FC2672	3/4
FC2673	13/16
FC2674	7/8
FC2675	15/16
FC2676	1
FC2677	1-1/16
FC2678	1-1/8
FC2679	1-3/16
FC2680	1-1/4
FC2681	1-5/16
FC2682	1-3/8
FC2683	1-7/16
FC2684	1-1/2
FC2685	1-9/16
FC2686	1-5/8
FC2687	1-11/16
FC2688	1-3/4
FC2689	1-13/16
FC2690	1-7/8
FC2691	1-15/16
FC2692	2
FC2693	2-1/8
FC2694	2-1/4
FC2695	2-3/8
FC2696	2-1/2
FC2697	2-5/8
FC2698	2-3/4
FC2699	2-7/8
FC2700	3
FC2701	3-1/4
FC2702	3-1/2
FC2703	3-3/4
FC2704	4
FC2705	4-1/4
FC2706	4-1/2
FC2707	4-3/4
FC2708	5
FC2709	5-1/4
FC2710	5-1/2
FC2711	5-3/4
FC2712	6

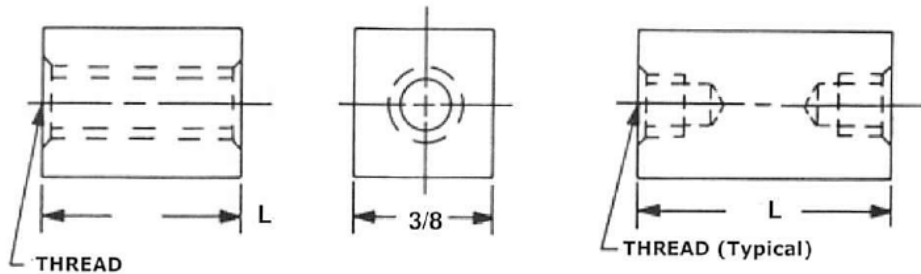

- Contact Sales Office for sizes not shown
- Source Control Drawing: To be produced by Fascomp Electronic Hardware

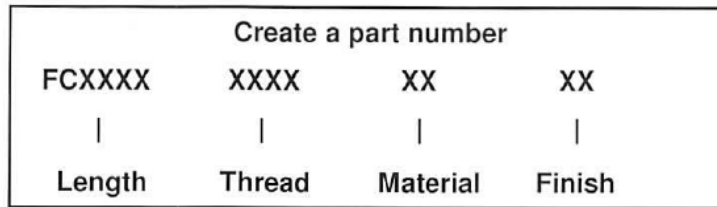

Thread			
Thread Code (XXX)	Tapped Thru		Longer Parts
	A, B, S	SS	Blind Tap Depth
632	1	1	3/8
832	1	1	7/16
1032	1-1/8	1	1/2
1224	1-1/8	1	1/2
2520	1-1/4	1-1/4	5/8

Material	
Material Code (XX)	
A	Aluminum
B	Brass
S	Steel
SS	Stainless Steel
N	Nylon

See page 3 for finish codes

Aluminum (A), Brass (B), Steel (S), Stainless Steel (SS)



Fascomp Electronic Hardware
 7814 Kingspointe Pkwy
 Orlando, FL 32819
 www.fascomp.com
 Tel: (407) 226-2112
 (407) 226-3370



Get quote >>

Angic Global Solutions

1-888-872-0690

<https://www.AngicGlobal.com> Sales@AngicGlobal.com

1/2 Square Female Standoff

FCXXX	Length (L)
FC2729	1/8
FC2730	3/16
FC2731	1/4
FC2732	5/16
FC2733	3/8
FC2734	7/16
FC2735	1/2
FC2736	9/16
FC2737	5/8
FC2738	11/16
FC2739	3/4
FC2740	13/16
FC2741	7/8
FC2742	15/16
FC2743	1
FC2744	1-1/16
FC2745	1-1/8
FC2746	1-3/16
FC2747	1-1/4
FC2748	1-5/16
FC2749	1-3/8
FC2750	1-7/16
FC2751	1-1/2
FC2752	1-9/16
FC2753	1-5/8
FC2754	1-11/16
FC2755	1-3/4
FC2756	1-13/16
FC2757	1-7/8
FC2758	1-15/16
FC2759	2
FC2760	2-1/8
FC2761	2-1/4
FC2762	2-3/8
FC2763	2-1/2
FC2764	2-5/8
FC2765	2-3/4
FC2766	2-7/8
FC2767	3
FC2768	3-1/4
FC2769	3-1/2
FC2770	3-3/4
FC2771	4
FC2772	4-1/4
FC2773	4-1/2
FC2774	4-3/4
FC2775	5
FC2776	5-1/4
FC2777	5-1/2
FC2778	5-3/4
FC2779	6

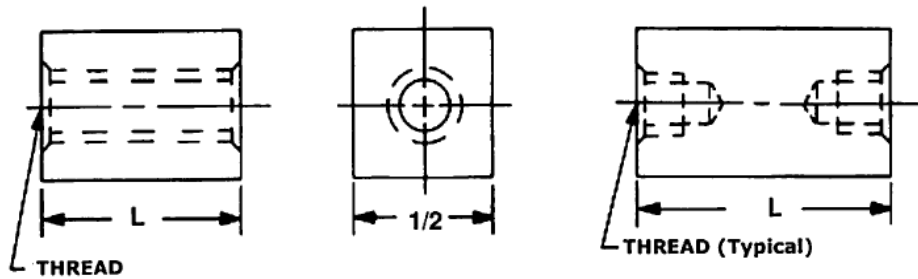

- Contact Sales Office for sizes not shown
- Source Control Drawing: To be produced by Fascomp Electronic Hardware

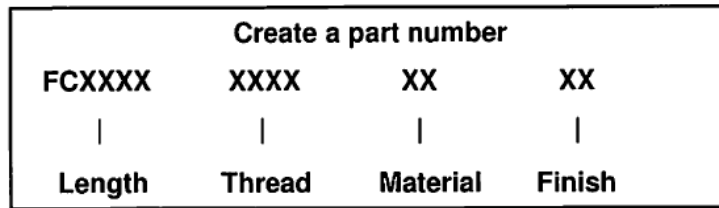

Thread			
Thread Code (XXX)	Tapped Thru		Longer Parts
	A, B, S	SS	Blind Tap Depth
632	1	1	3/8
832	1	1	7/16
1032	1-1/8	1	1/2
1224	1-1/8	1	1/2
2520	1-1/4	1-1/4	5/8

Aluminum (A), Brass (B), Steel (S), Stainless Steel (SS)

Material	
Material Code (XX)	
A	Aluminum
B	Brass
S	Steel
SS	Stainless Steel
N	Nylon

See page 3 for finish codes



Fascomp Electronic Hardware
 7814 Kingspointe Pkwy
 Orlando, FL 32819
 www.fascomp.com
 Tel: (407) 226-2112
 Fax: (407) 226-3



5/8 Square Female Standoff

FCXXX	Length (L)
FC2796	1/8
FC2797	3/16
FC2798	1/4
FC2799	5/16
FC2800	3/8
FC2801	7/16
FC2802	1/2
FC2803	9/16
FC2804	5/8
FC2805	11/16
FC2806	3/4
FC2807	13/16
FC2808	7/8
FC2809	15/16
FC2810	1
FC2811	1-1/16
FC2812	1-1/8
FC2813	1-3/16
FC2814	1-1/4
FC2815	1-5/16
FC2816	1-3/8
FC2817	1-7/16
FC2818	1-1/2
FC2819	1-9/16
FC2820	1-5/8
FC2821	1-11/16
FC2822	1-3/4
FC2823	1-13/16
FC2824	1-7/8
FC2825	1-15/16
FC2826	2
FC2827	2-1/8
FC2828	2-1/4
FC2829	2-3/8
FC2830	2-1/2
FC2831	2-5/8
FC2832	2-3/4
FC2833	2-7/8
FC2834	3
FC2835	3-1/4
FC2836	3-1/2
FC2837	3-3/4
FC2838	4
FC2839	4-1/4
FC2840	4-1/2
FC2841	4-3/4
FC2842	5
FC2843	5-1/4
FC2844	5-1/2
FC2845	5-3/4
FC2846	

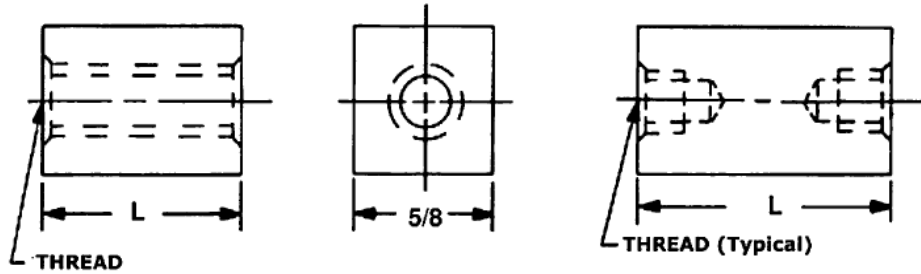

- Contact Sales Office for sizes not shown
- Source Control Drawing: To be produced by Fascomp Electronic Hardware

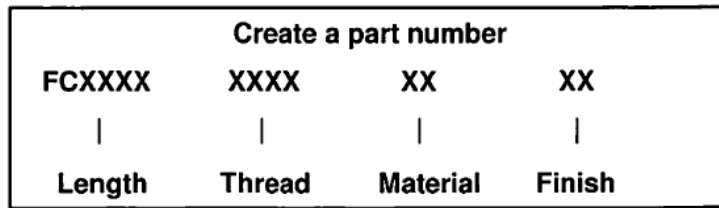

Thread			
Thread Code (XXX)	Tapped Thru		Longer Parts
	A, B, S	SS	Blind Tap Depth
832	1	1	7/16
1032	1-1/8	1	1/2
1224	1-1/8	1	1/2
2520	1-1/4	1-1/4	5/8

Aluminum (A), Brass (B), Steel (S), Stainless Steel (SS)

Material	
Material Code (XX)	
A	Aluminum
B	Brass
S	Steel
SS	Stainless Steel
N	Nylon

See page 3 for finish codes



Fascomp Electronic Hardware
 7814 Kingspointe Pkwy
 Orlando, FL 32819
 www.fascomp.com
 Tel: (407) 226-2112
 Fax: (407) 226-3337



Get quote >>

Angic Global Solutions

1-888-872-0690

<https://www.AngicGlobal.com> Sales@AngicGlobal.com



Swage Standoffs



Fascomp stocks both hex and round Swage Standoffs in aluminum, brass, steel, and stainless steel.

	Page No.
1/8 Round	109
5/32 Round	110
3/16 Round	111
1/4 Round	112
5/16 Round	113
3/8 Round	114
1/8 Hex	115
5/32 Hex	116
3/16 Hex	117
1/4 Hex	118
5/16 Hex	119
3/8 Hex	120



Fascomp Electronic Hardware
7814 Kingspointe Pkwy
Orlando, FL 32819
www.fascomp.com
Tel: (407) 226-2112
(407) 226-3370



1/8 Round Swage Standoff

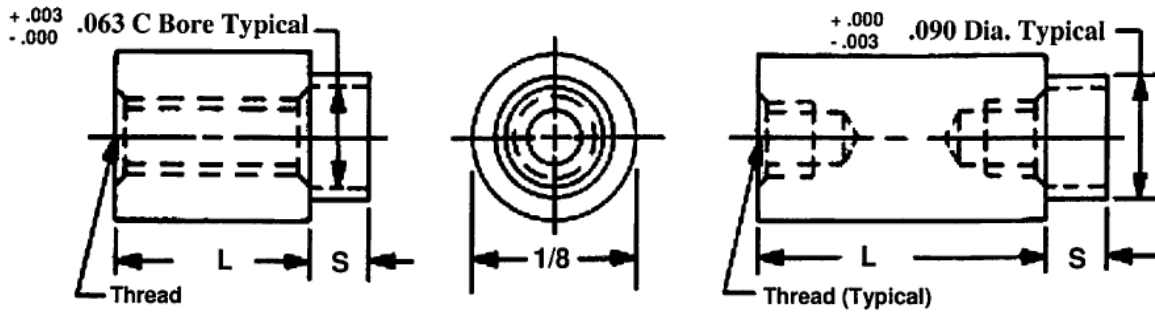

- Contact Sales Office for sizes not shown
- Source Control Drawing: To be produced by Fascomp Electronic Hardware

FCXXX	Length (L)
FC3000	1/8
FC3001	3/16
FC3002	1/4
FC3003	5/16
FC3004	3/8
FC3005	7/16
FC3006	1/2
FC3007	9/16
FC3008	5/8
FC3009	11/16
FC3010	3/4
FC3011	13/16
FC3012	7/8
FC3013	15/16
FC3014	1

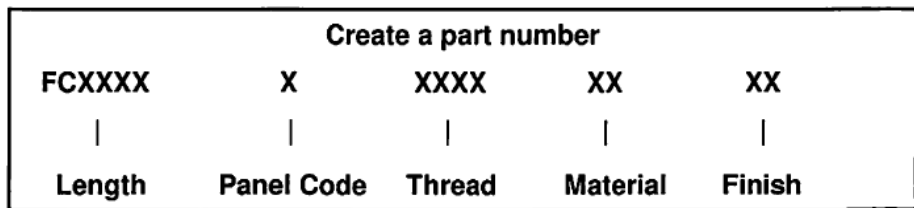

Swage Panel/Code (X)		
S	+ .003 - .003	P
A	.075	1/32
B	.105	1/16
C	.135	3/32
D	.165	1/8
E	.230	3/16
F	.290	1/4

Thread	
Thread Code (XXX)	Thread
080	0-80

Material	
Material Code (XX)	
A	Aluminum
B	Brass
S	Steel
SS	Stainless Steel

See page 3 for finish codes



Fascomp Electronic Hardware
 7814 Kingspointe Pkwy
 Orlando, FL 32819
 www.fascomp.com
 Tel: (407) 226-2112
 (407) 226-3370



Get quote >>

Angic Global Solutions 1-888-872-0690
<https://www.AngicGlobal.com> Sales@AngicGlobal.com

5/32 Round Swage Standoff

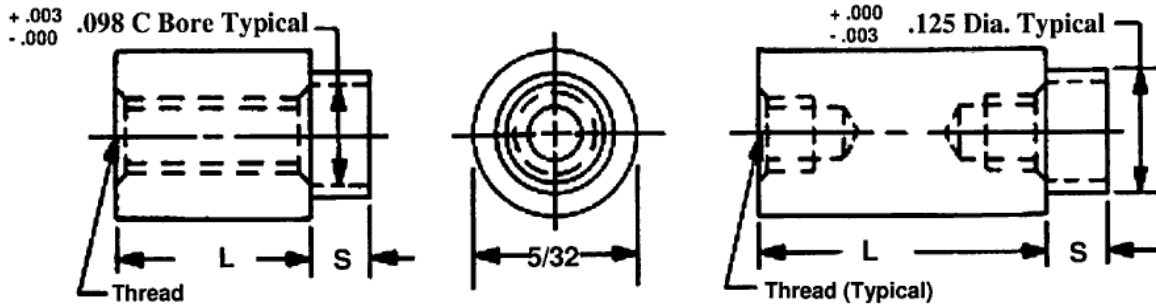

- Contact Sales Office for sizes not shown
- Source Control Drawing: To be produced by Fascomp Electronic Hardware

FCXXX	Length (L)
FC3015	1/8
FC3016	3/16
FC3017	1/4
FC3018	5/16
FC3019	3/8
FC3020	7/16
FC3021	1/2
FC3022	9/16
FC3023	5/8
FC3024	11/16
FC3025	3/4
FC3026	13/16
FC3027	7/8
FC3028	15/16
FC3029	1

Create a part number

FCXXX	X	XXX	XX	XX
Length	Panel Code	Thread	Material	Finish

Swage Panel/Code (X)		
S	+ .003 - .003	P
A	.075	1/32
B	.105	1/16
C	.135	3/32
D	.165	1/8
E	.230	3/16
F	.290	1/4

Thread	
Thread Code (XXX)	Thread
080	0-80
256	2-56

Material	
Material Code (XX)	
A	Aluminum
B	Brass
S	Steel
SS	Stainless Steel

See page 3 for finish codes



Fascomp Electronic Hardware
 7814 Kingspointe Pkwy
 Orlando, FL 32819
 www.fascomp.com
 Tel: (407) 226-2112
 (407) 226-3370



Get quote >>

3/16 Round Swage Standoff

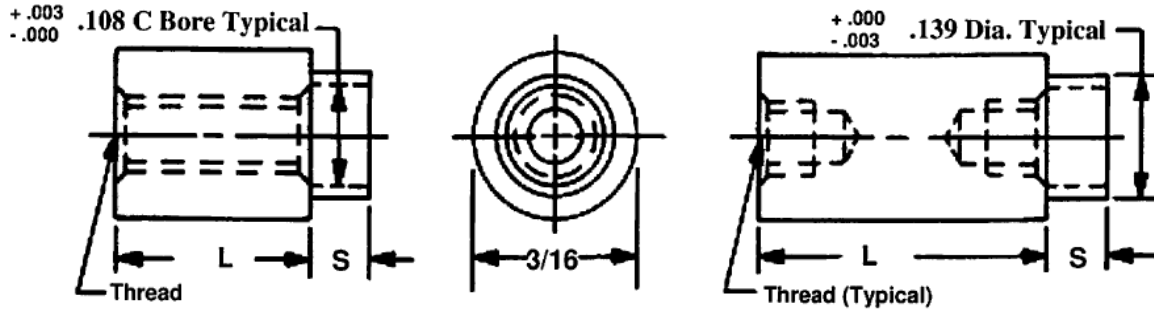

- Contact Sales Office for sizes not shown
- Source Control Drawing: To be produced by Fascomp Electronic Hardware

FCXXX	Length (L)
FC3030	1/8
FC3031	3/16
FC3032	1/4
FC3033	5/16
FC3034	3/8
FC3035	7/16
FC3036	1/2
FC3037	9/16
FC3038	5/8
FC3039	11/16
FC3040	3/4
FC3041	13/16
FC3042	7/8
FC3043	15/16
FC3044	1

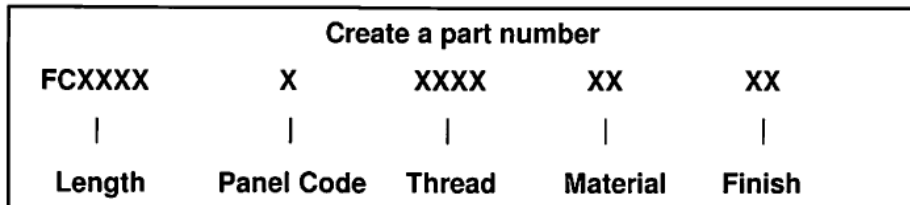

Swage Panel/Code (X)		
S	+ .003 - .003	P
A	.075	1/32
B	.105	1/16
C	.135	3/32
D	.165	1/8
E	.230	3/16
F	.290	1/4

Thread	
Thread Code (XXX)	Thread
256	2-56
348	3-48

Material	
Material Code (XX)	
A	Aluminum
B	Brass
S	Steel
SS	Stainless Steel

See page 3 for finish codes



Fascomp Electronic Hardware
 7814 Kingspointe Pkwy
 Orlando, FL 32819
 www.fascomp.com
 Tel: (407) 226-2112
 (407) 226-3370



Get quote >>

Angic Global Solutions 1-888-872-0690
<https://www.AngicGlobal.com> Sales@AngicGlobal.com

1/4 Round Swage Standoff

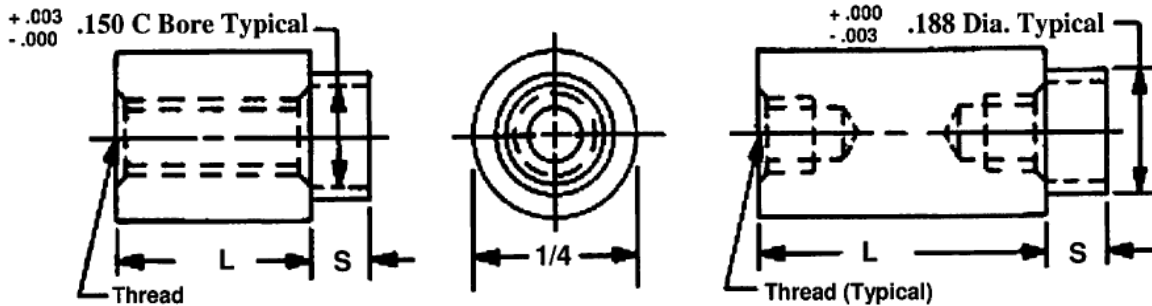

- Contact Sales Office for sizes not shown
- Source Control Drawing: To be produced by Fascomp Electronic Hardware

FCXXXX	Length (L)
FC3045	1/8
FC3046	3/16
FC3047	1/4
FC3048	5/16
FC3049	3/8
FC3050	7/16
FC3051	1/2
FC3052	9/16
FC3053	5/8
FC3054	11/16
FC3055	3/4
FC3056	13/16
FC3057	7/8
FC3058	15/16
FC3059	1
FC3060	1-1/16
FC3061	1-1/8
FC3062	1-3/16
FC3063	1-1/4
FC3064	1-5/16
FC3065	1-3/8
FC3066	1-7/16
FC3067	1-1/2
FC3068	1-9/16
FC3069	1-5/8
FC3070	1-11/16
FC3072	1-3/4
FC3073	1-13/16
FC3073	1-7/8
FC3074	1-15/16
FC3075	2

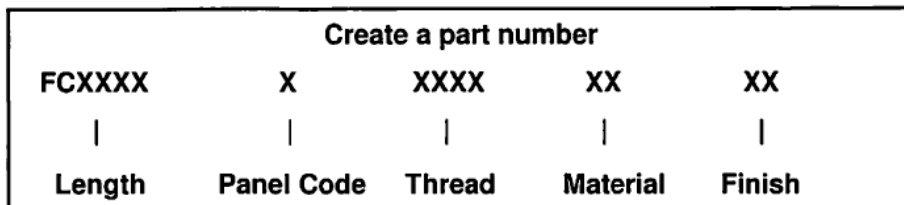

Swage Panel/Code (X)		
S	+ .003 - .003	P
A	.075	1/32
B	.105	1/16
C	.135	3/32
D	.165	1/8
E	.230	3/16
F	.290	1/4

Thread	
Thread Code (XXX)	Thread
256	2-56
348	3-48
440	4-40
632	6-32

Material	
Material Code (XX)	
A	Aluminum
B	Brass
S	Steel
SS	Stainless Steel

See page 3 for finish codes



Fascomp Electronic Hardware
7814 Kingspointe Pkwy
Orlando, FL 32819
www.fascomp.com
Tel: (407) 226-2112
(407) 226-3370



5/16 Round Swage Standoff

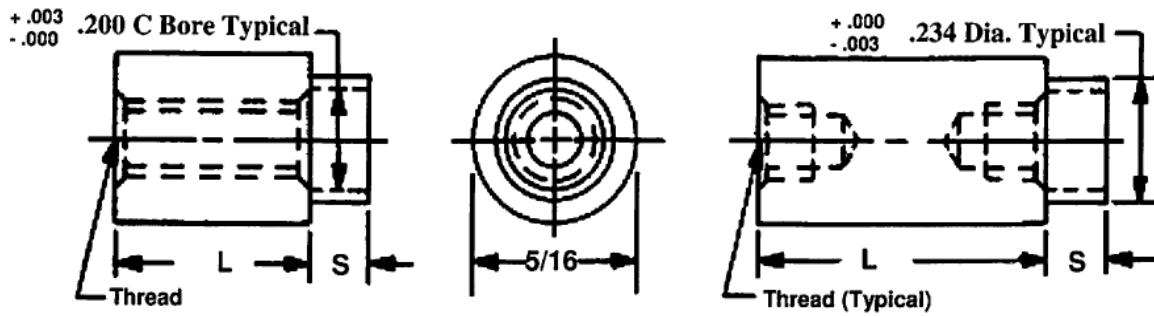

- Contact Sales Office for sizes not shown
- Source Control Drawing: To be produced by Fascomp Electronic Hardware

FCXXXX	Length (L)
FC3076	1/8
FC3077	3/16
FC3078	1/4
FC3079	5/16
FC3080	3/8
FC3081	7/16
FC3082	1/2
FC3083	9/16
FC3084	5/8
FC3085	11/16
FC3086	3/4
FC3087	13/16
FC3088	7/8
FC3089	15/16
FC3090	1
FC3091	1-1/16
FC3092	1-1/8
FC3093	1-3/16
FC3094	1-1/4
FC3095	1-5/16
FC3096	1-3/8
FC3097	1-7/16
FC3098	1-1/2
FC3099	1-9/16
FC3100	1-5/8
FC3101	1-11/16
FC3102	1-3/4
FC3103	1-13/16
FC3104	1-7/8
FC3105	1-15/16
FC3106	2

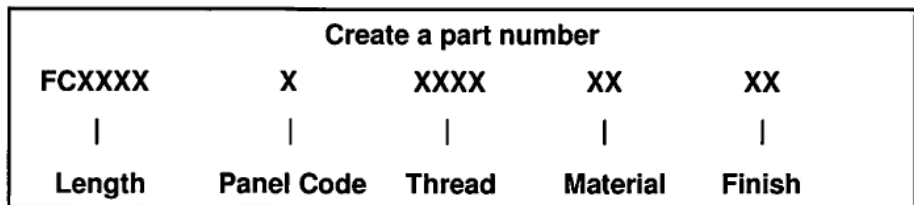

Swage Panel/Code (X)		
S	+ .003 - .003	P
A	.075	1/32
B	.105	1/16
C	.135	3/32
D	.165	1/8
E	.230	3/16
F	.290	1/4

Thread	
Thread Code (XXX)	Thread
440	4-40
632	6-32
832	8-32
1032	10-32

Material	
Material Code (XX)	
A	Aluminum
B	Brass
S	Steel
SS	Stainless Steel

See page 3 for finish codes



Fascomp Electronic Hardware
7814 Kingspointe Pkwy
Orlando, FL 32819
www.fascomp.com
Tel: (407) 226-2112
(407) 226-3370



Get quote >>

Angic Global Solutions 1-888-872-0690
<https://www.AngicGlobal.com> Sales@AngicGlobal.com

3/8 Round Swage Standoff

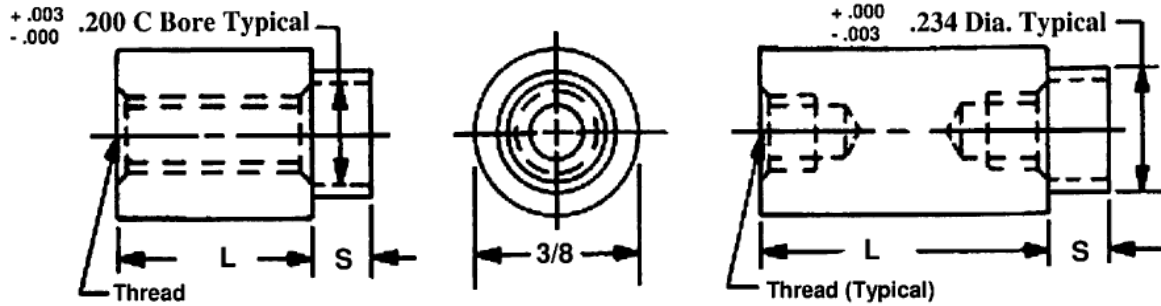

- Contact Sales Office for sizes not shown
- Source Control Drawing: To be produced by Fascomp Electronic Hardware

FCXXX	Length (L)
FC3107	1/8
FC3108	3/16
FC3109	1/4
FC3110	5/16
FC3111	3/8
FC3112	7/16
FC3113	1/2
FC3114	9/16
FC3115	5/8
FC3116	11/16
FC3117	3/4
FC3118	13/16
FC3119	7/8
FC3120	15/16
FC3121	1
FC3122	1-1/16
FC3123	1-1/8
FC3124	1-3/16
FC3125	1-1/4
FC3126	1-5/16
FC3127	1-3/8
FC3128	1-7/16
FC3129	1-1/2
FC3130	1-9/16
FC3131	1-5/8
FC3132	1-11/16
FC3133	1-3/4
FC3134	1-13/16
FC3135	1-7/8
FC3136	1-15/16
FC3137	2

Create a part number				
FCXXX	X	XXX	XX	XX
Length	Panel Code	Thread	Material	Finish

Swage Panel/Code (X)		
S	+ .003 - .003	P
A	.075	1/32
B	.105	1/16
C	.135	3/32
D	.165	1/8
E	.230	3/16
F	.290	1/4

Thread	
Thread Code (XXX)	Thread
440	4-40
632	6-32
832	8-32
1032	10-32

Material	
Material Code (XX)	
A	Aluminum
B	Brass
S	Steel
SS	Stainless Steel

See page 3 for finish codes



Fascomp Electronic Hardware
7814 Kingspointe Pkwy
Orlando, FL 32819
www.fascomp.com
Tel: (407) 226-2112
 (407) 226-3370



1/8 Hex Swage Standoff

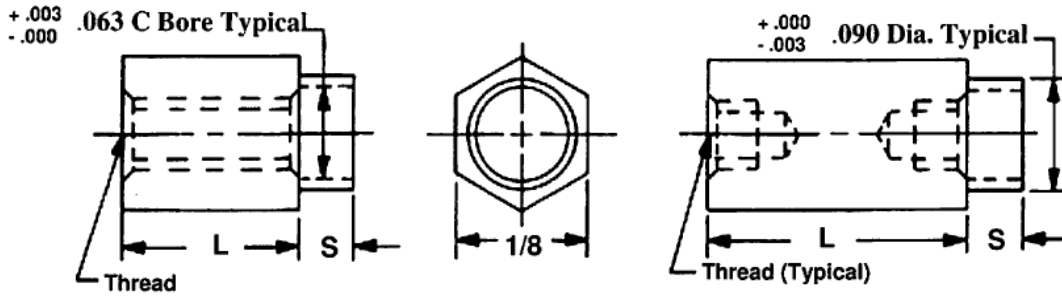

- Contact Sales Office for sizes not shown
- Source Control Drawing: To be produced by Fascomp Electronic Hardware

FCXXXX	Length (L)
FC3500	1/8
FC3501	3/16
FC3502	1/4
FC3503	5/16
FC3504	3/8
FC3505	7/16
FC3506	1/2
FC3507	9/16
FC3508	5/8
FC3509	11/16
FC3510	3/4
FC3511	13/16
FC3512	7/8
FC3513	15/16
FC3514	1

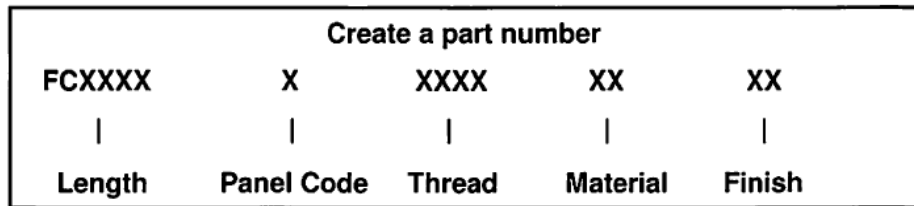

Swage Panel/Code (X)		
S	+ .003 - .003	P
A	.075	1/32
B	.105	1/16
C	.135	3/32
D	.165	1/8
E	.230	3/16
F	.290	1/4

Thread	
Thread Code (XXX)	Thread
080	0-80

Material	
Material Code (XX)	
A	Aluminum
B	Brass
S	Steel
SS	Stainless Steel

See page 3 for finish codes



Fascomp Electronic Hardware
 7814 Kingspointe Pkwy
 Orlando, FL 32819
 www.fascomp.com
 Tel: (407) 226-2112
 226-3370



Get quote >>

Angic Global Solutions 1-888-872-0690 5
<https://www.AngicGlobal.com> Sales@AngicGlobal.com

5/32 Hex Swage Standoff

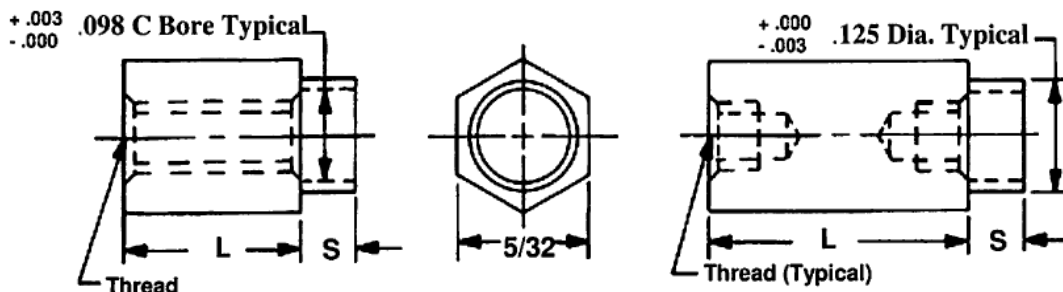

- Contact Sales Office for sizes not shown
- Source Control Drawing: To be produced by Fascomp Electronic Hardware

FCXXX	Length (L)
FC3515	1/8
FC3516	3/16
FC3517	1/4
FC3518	5/16
FC3519	3/8
FC3520	7/16
FC3521	1/2
FC3522	9/16
FC3523	5/8
FC3524	11/16
FC3525	3/4
FC3526	13/16
FC3527	7/8
FC3528	15/16
FC3529	1

Create a part number				
FCXXX	X	XXX	XX	XX
Length	Panel Code	Thread	Material	Finish

Swage Panel/Code (X)		
S	+ .003 - .003	P
A	.075	1/32
B	.105	1/16
C	.135	3/32
D	.165	1/8
E	.230	3/16
F	.290	1/4

Thread	
Thread Code (XXX)	Thread
080	0-80
256	2-56

Material	
Material Code (XX)	
A	Aluminum
B	Brass
S	Steel
SS	Stainless Steel

See page 3 for finish codes



Fascomp Electronic Hardware
 7814 Kingspointe Pkwy
 Orlando, FL 32819
 www.fascomp.com
 Tel: (407) 226-2112
 226-3370



3/16 Hex Swage Standoff

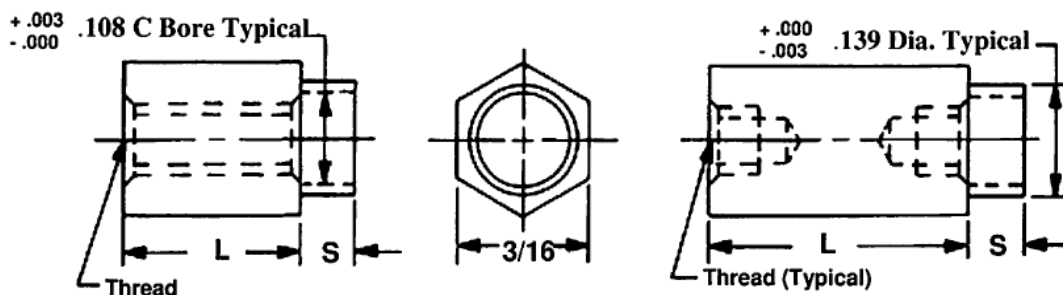

- Contact Sales Office for sizes not shown
- Source Control Drawing: To be produced by Fascomp Electronic Hardware

FCXXXX	Length (L)
FC3530	1/8
FC3531	3/16
FC3532	1/4
FC3533	5/16
FC3534	3/8
FC3535	7/16
FC3536	1/2
FC3537	9/16
FC3538	5/8
FC3539	11/16
FC3540	3/4
FC3541	13/16
FC3542	7/8
FC3543	15/16
FC3544	1

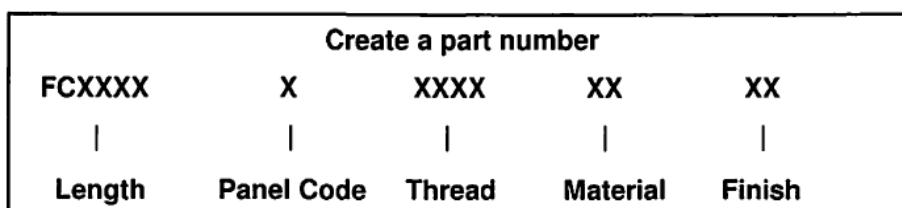

Swage Panel/Code (X)		
S	+ .003 - .003	P
A	.075	1/32
B	.105	1/16
C	.135	3/32
D	.165	1/8
E	.230	3/16
F	.290	1/4

Thread	
Thread Code (XXX)	Thread
256	2-56
348	3-48

Material	
Material Code (XX)	
A	Aluminum
B	Brass
S	Steel
SS	Stainless Steel

See page 3 for finish codes



Fascomp Electronic Hardware
7814 Kingspointe Pkwy
Orlando, FL 32819
www.fascomp.com
Tel: (407) 226-2112
226-3370



Get quote >>

Angic Global Solutions 1-888-872-0690
<https://www.AngicGlobal.com> Sales@AngicGlobal.com

1/4 Hex Swage Standoff

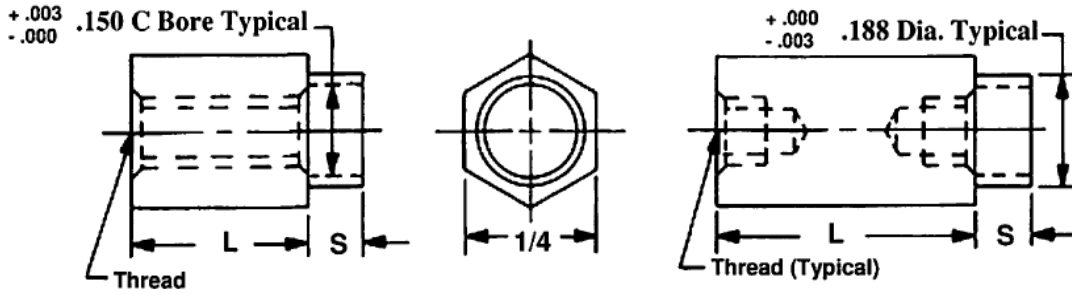

- Contact Sales Office for sizes not shown
- Source Control Drawing: To be produced by Fascomp Electronic Hardware

FCXXX	Length (L)
FC3545	1/8
FC3546	3/16
FC3547	1/4
FC3548	5/16
FC3549	3/8
FC3550	7/16
FC3551	1/2
FC3552	9/16
FC3553	5/8
FC3554	11/16
FC3555	3/4
FC3556	13/16
FC3557	7/8
FC3558	15/16
FC3559	1
FC3560	1-1/16
FC3561	1-1/8
FC3562	1-3/16
FC3563	1-1/4
FC3564	1-5/16
FC3565	1-3/8
FC3566	1-7/16
FC3567	1-1/2
FC3568	1-9/16
FC3569	1-5/8
FC3570	1-11/16
FC3572	1-3/4
FC3573	1-13/16
FC3573	1-7/8
FC3574	1-15/16
FC3575	2

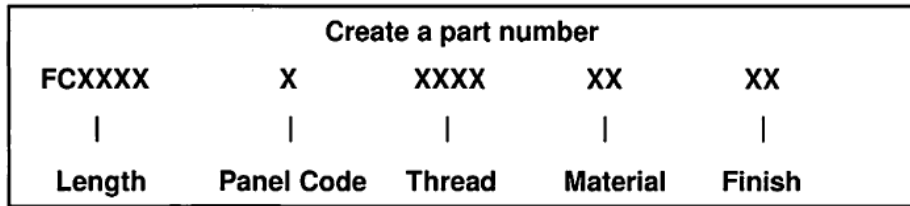

Swage Panel/Code (X)		
S	+ .003 - .003	P
A	.075	1/32
B	.105	1/16
C	.135	3/32
D	.165	1/8
E	.230	3/16
F	.290	1/4

Thread	
Thread Code (XXX)	Thread
256	2-56
348	3-48
440	4-40
632	6-32

Material	
Material Code (XX)	
A	Aluminum
B	Brass
S	Steel
SS	Stainless Steel

See page 3 for finish codes



Fascomp Electronic Hardware
 7814 Kingspointe Pkwy
 Orlando, FL 32819
 www.fascomp.com
 Tel: (407) 226-2112
 226-3370



5/16 Hex Swage Standoff

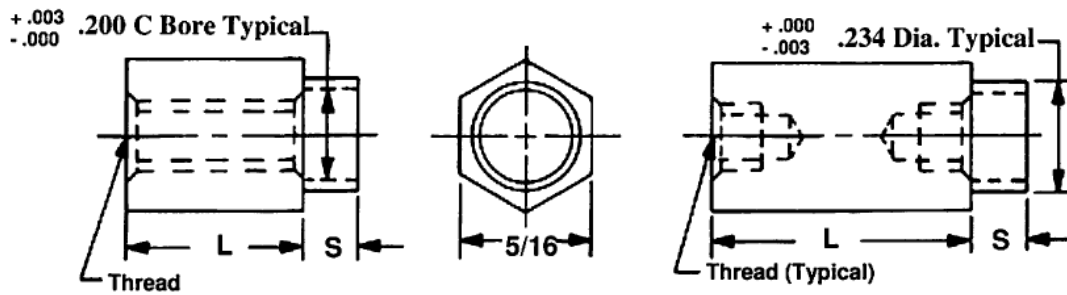

- Contact Sales Office for sizes not shown
- Source Control Drawing: To be produced by Fascomp Electronic Hardware

FCXXX	Length (L)
FC3576	1/8
FC3577	3/16
FC3578	1/4
FC3579	5/16
FC3580	3/8
FC3581	7/16
FC3582	1/2
FC3583	9/16
FC3584	5/8
FC3585	11/16
FC3586	3/4
FC3587	13/16
FC3588	7/8
FC3589	15/16
FC3590	1
FC3591	1-1/16
FC3592	1-1/8
FC3593	1-3/16
FC3594	1-1/4
FC3595	1-5/16
FC3596	1-3/8
FC3597	1-7/16
FC3598	1-1/2
FC3599	1-9/16
FC3600	1-5/8
FC3601	1-11/16
FC3602	1-3/4
FC3603	1-13/16
FC3604	1-7/8
FC3605	1-15/16
FC3606	2

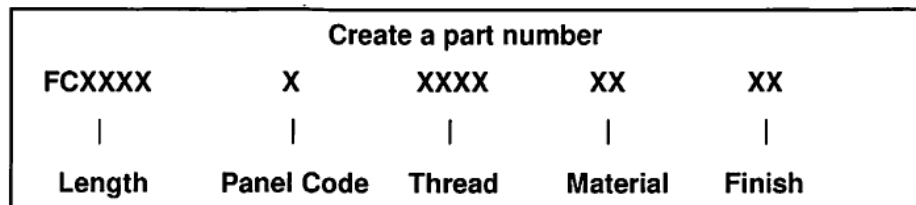

Swage Panel/Code (X)		
S	+ .003 - .003	P
A	.075	1/32
B	.105	1/16
C	.135	3/32
D	.165	1/8
E	.230	3/16
F	.290	1/4

Thread	
Thread Code (XXX)	Thread
440	4-40
632	6-32
832	8-32
1032	10-32

Material	
Material Code (XX)	
A	Aluminum
B	Brass
S	Steel
SS	Stainless Steel

See page 3 for finish codes



Fascomp Electronic Hardware
 7814 Kingspointe Pkwy
 Orlando, FL 32819
 www.fascomp.com
 Tel: (407) 226-2112
 226-3370



Get quote >>

Angic Global Solutions 1-888-872-0690
<https://www.AngicGlobal.com> Sales@AngicGlobal.com

3/8 Hex Swage Standoff

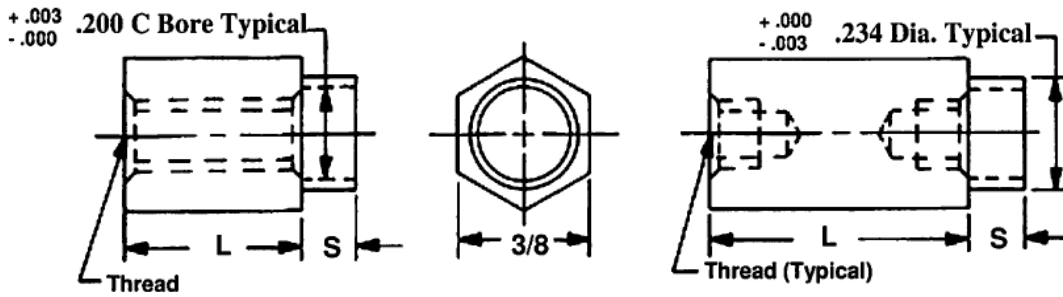

- Contact Sales Office for sizes not shown
- Source Control Drawing: To be produced by Fascomp Electronic Hardware

FCXXXX	Length (L)
FC3607	1/8
FC3608	3/16
FC3609	1/4
FC3610	5/16
FC3611	3/8
FC3612	7/16
FC3613	1/2
FC3614	9/16
FC3615	5/8
FC3616	11/16
FC3617	3/4
FC3618	13/16
FC3619	7/8
FC3620	15/16
FC3621	1
FC3622	1-1/16
FC3623	1-1/8
FC3624	1-3/16
FC3625	1-1/4
FC3626	1-5/16
FC3627	1-3/8
FC3628	1-7/16
FC3629	1-1/2
FC3630	1-9/16
FC3631	1-5/8
FC3632	1-11/16
FC3633	1-3/4
FC3634	1-13/16
FC3635	1-7/8
FC3636	1-15/16
FC3637	2

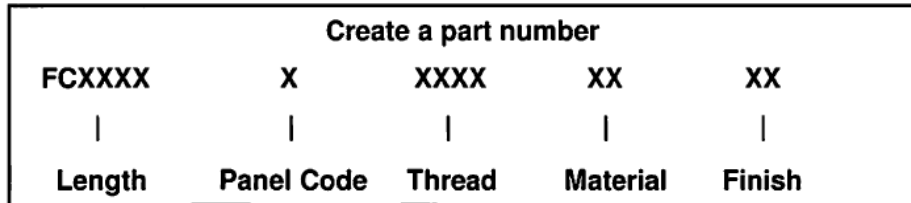

Swage Panel/Code (X)		
S	+ .003 - .003	P
A	.075	1/32
B	.105	1/16
C	.135	3/32
D	.165	1/8
E	.230	3/16
F	.290	1/4

Thread	
Thread Code (XXX)	Thread
440	4-40
632	6-32
832	8-32
1032	10-32

Material	
Material Code (XX)	
A	Aluminum
B	Brass
S	Steel
SS	Stainless Steel

See page 3 for finish codes



Fascomp Electronic Hardware
 7814 Kingspointe Pkwy
 Orlando, FL 32819
 www.fascomp.com
) 226-2112
) 226-3370





Male-Female Standoffs



Fascomp stocks both hex and round Male-Female Standoffs in aluminum, brass, steel, stainless steel and nylon.

	Page No.
3/16 Round	122
1/4 Round	123
5/16 Round	124
3/8 Round	125
1/2 Round	126
3/16 Hex	127
1/4 Hex	128
5/16 Hex	129
3/8 Hex	130
1/2 Hex	131



Fascomp Electronic Hardware
7814 Kingspointe Pkwy
Orlando, FL 32819
www.fascomp.com
Tel: (407) 226-2112
(407) 226-3370



Get quote

Angic Global Solutions 1-888-872-0690
<https://www.AngicGlobal.com> Sales@AngicGlobal.com

3/16 Round Male-Female Standoff

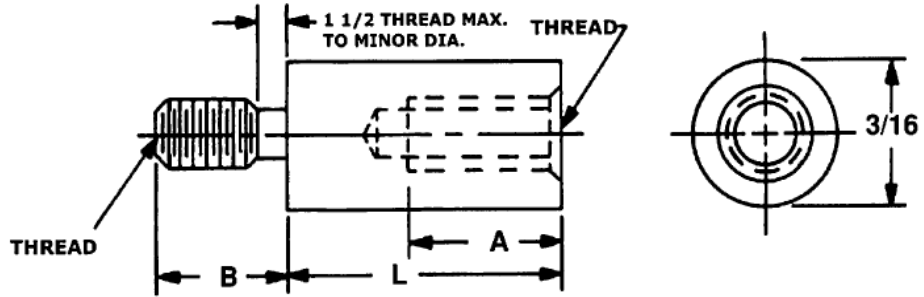

- Contact Sales Office for sizes not shown
- Source Control Drawing: To be produced by Fascomp Electronic Hardware

FCXXXX	Length (L)
FC4000	3/16
FC4001	1/4
FC4002	5/16
FC4003	3/8
FC4004	7/16
FC4005	1/2
FC4006	9/16
FC4007	5/8
FC4008	11/16
FC4009	3/4
FC4010	13/16
FC4011	7/8
FC4012	15/16
FC4013	1
FC4014	1-1/16
FC4015	1-1/8
FC4016	1-3/16
FC4017	1-1/4
FC4018	1-5/16
FC4019	1-3/8
FC4020	1-7/16
FC4021	1-1/2
FC4022	1-9/16
FC4023	1-5/8
FC4024	1-11/16
FC4025	1-3/4
FC4026	1-13/16
FC4027	1-7/8
FC4028	1-15/16
FC4029	2

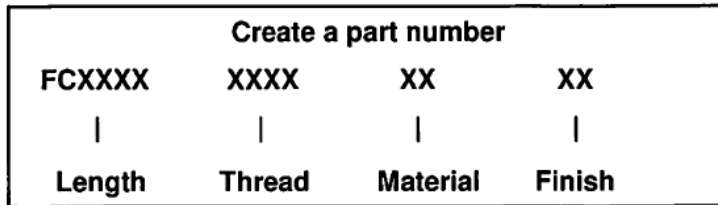

Thread		
Short lengths, 'A' tapped to maximum depth		
Thread Code (XXX)	Depth (A)	Length (B)
256	3/16	5/32
440	1/4	3/16
632	3/8	1/4

Material	
Material Code (XX)	
A	Aluminum
B	Brass
S	Steel
SS	Stainless Steel
N	Nylon

See page 3 for finish codes



Fascomp Electronic Hardware
 7814 Kingspointe Pkwy
 Orlando, FL 32819
 www.fascomp.com
 Tel: (407) 226-21
 Fax: (407) 226-31



1/4 Round Male-Female Standoff

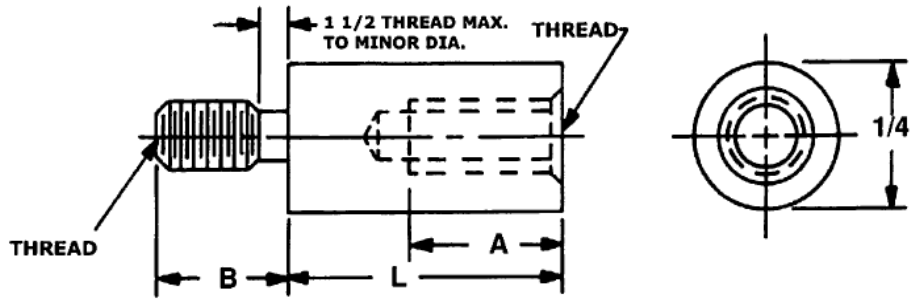

FCXXXX	Length (L)
FC4030	1/4
FC4031	5/16
FC4032	3/8
FC4033	7/16
FC4034	1/2
FC4035	9/16
FC4036	5/8
FC4037	11/16
FC4038	3/4
FC4039	13/16
FC4040	7/8
FC4041	15/16
FC4042	1
FC4043	1-1/16
FC4044	1-1/8
FC4045	1-3/16
FC4046	1-1/4
FC4047	1-5/16
FC4048	1-3/8
FC4049	1-7/16
FC4050	1-1/2
FC4051	1-9/16
FC4052	1-5/8
FC4053	1-11/16
FC4054	1-3/4
FC4055	1-13/16
FC4056	1-7/8
FC4057	1-15/16
FC4058	2
FC4059	2-1/8
FC4060	2-1/4
FC4061	2-3/8
FC4062	2-1/2
FC4063	2-5/8
FC4064	2-3/4
FC4065	2-7/8
FC4066	3
FC4067	3-1/4
FC4068	3-1/2
FC4069	3-3/4
FC4070	4

- Contact Sales Office for sizes not shown
- Source Control Drawing: To be produced by Fascomp Electronic Hardware

Create a part number			
FCXXXX	XXXX	XX	XX
Length	Thread	Material	Finish

Thread		
Short lengths, 'A' tapped to maximum depth		
Thread Code (XXX)	Depth (A)	Length (B)
256	3/16	5/32
440	1/4	3/16
632	3/8	1/4
832	7/16	3/8

Material	
Material Code (XX)	
A	Aluminum
B	Brass
S	Steel
SS	Stainless Steel
N	Nylon

See page 3 for finish codes



Fascomp Electronic Hardware
 7814 Kingspointe Pkwy
 Orlando, FL 32819
 www.fascomp.com
 Tel: (407) 2
 Fax: (407) 2



Get quote >>

Angic Global Solutions 1-888-872-0690
<https://www.AngicGlobal.com> Sales@AngicGlobal.com

5/16 Round Male-Female Standoff

FCXXX	Length (L)
FC4071	1/4
FC4072	5/16
FC4073	3/8
FC4074	7/16
FC4075	1/2
FC4076	9/16
FC4077	5/8
FC4078	11/16
FC4079	3/4
FC4080	13/16
FC4081	7/8
FC4082	15/16
FC4083	1
FC4084	1-1/16
FC4085	1-1/8
FC4086	1-3/16
FC4087	1-1/4
FC4088	1-5/16
FC4089	1-3/8
FC4090	1-7/16
FC4091	1-1/2
FC4092	1-9/16
FC4093	1-5/8
FC4094	1-11/16
FC4095	1-3/4
FC4096	1-13/16
FC4097	1-7/8
FC4098	1-15/16
FC4099	2
FC4100	2-1/8
FC4101	2-1/4
FC4102	2-3/8
FC4103	2-1/2
FC4104	2-5/8
FC4105	2-3/4
FC4106	2-7/8
FC4107	3
FC4108	3-1/4
FC4109	3-1/2
FC4110	3-3/4
FC4111	4
FC4112	4-1/4
FC4113	4-1/2
FC4114	4-3/4
FC4115	5
FC4116	5-1/4
FC4117	5-1/2
FC4118	5-3/4
FC4119	6

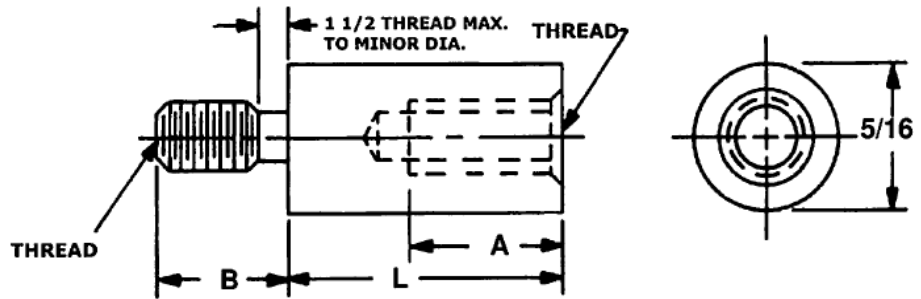

- Contact Sales Office for sizes not shown
- Source Control Drawing: To be produced by Fascomp Electronic Hardware

Create a part number			
FCXXX	XXXX	XX	XX
Length	Thread	Material	Finish

Thread		
Short lengths, 'A' tapped to maximum depth		
Thread Code (XXX)	Depth (A)	Length (B)
440	1/4	3/16
632	3/8	1/4
832	7/16	3/8
1032	1/2	3/8

Material	
Material Code (XX)	
A	Aluminum
B	Brass
S	Steel
SS	Stainless Steel
N	Nylon

See page 3 for finish codes



Fascomp Electronic Hardware
 7814 Kingspointe Pkwy
 Orlando, FL 32819
 www.fascomp.com
 Tel: (407) 226-
 Fax: (407) 226-



3/8 Round Male-Female Standoff

FCXXXX	Length (L)
FC4120	1/4
FC4121	5/16
FC4122	3/8
FC4123	7/16
FC4124	1/2
FC4125	9/16
FC4126	5/8
FC4127	11/16
FC4128	3/4
FC4129	13/16
FC4130	7/8
FC4131	15/16
FC4132	1
FC4133	1-1/16
FC4134	1-1/8
FC4135	1-3/16
FC4136	1-1/4
FC4137	1-5/16
FC4138	1-3/8
FC4139	1-7/16
FC4140	1-1/2
FC4141	1-9/16
FC4142	1-5/8
FC4143	1-11/16
FC4144	1-3/4
FC4145	1-13/16
FC4146	1-7/8
FC4147	1-15/16
FC4148	2
FC4149	2-1/8
FC4150	2-1/4
FC4151	2-3/8
FC4152	2-1/2
FC4153	2-5/8
FC4154	2-3/4
FC4155	2-7/8
FC4156	3
FC4157	3-1/4
FC4158	3-1/2
FC4159	3-3/4
FC4160	4
FC4161	4-1/4
FC4162	4-1/2
FC4163	4-3/4
FC4164	5
FC4165	5-1/4
FC4166	5-1/2
FC4167	5-3/4
FC4168	6

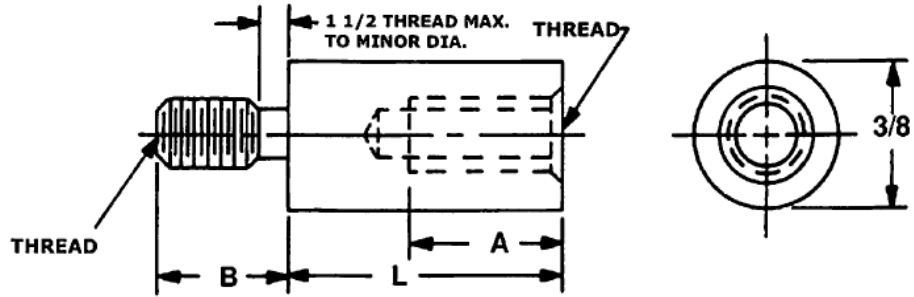

- Contact Sales Office for sizes not shown
- Source Control Drawing: To be produced by Fascomp Electronic Hardware

Create a part number			
FCXXXX	XXXX	XX	XX
Length	Thread	Material	Finish

Thread		
Short lengths, 'A' tapped to maximum depth		
Thread Code (XXX)	Depth (A)	Length (B)
440	1/4	3/16
632	3/8	1/4
832	7/16	3/8
1032	1/2	3/8
1224	1/2	3/8

Material	
Material Code (XX)	
A	Aluminum
B	Brass
S	Steel
SS	Stainless Steel
N	Nylon

See page 3 for finish codes



Fascomp Electronic Hardware
 7814 Kingspointe Pkwy
 Orlando, FL 32819
 www.fascomp.com
 Tel: (407) 226-2112
 Fax: (407) 226-3371



Get quote >>

Angic Global Solutions

1-888-872-0690

<https://www.AngicGlobal.com> Sales@AngicGlobal.com

1/2 Round Male-Female Standoff

FCXXXX	Length (L)
FC4169	1/4
FC4170	5/16
FC4171	3/8
FC4172	7/16
FC4173	1/2
FC4174	9/16
FC4175	5/8
FC4176	11/16
FC4177	3/4
FC4178	13/16
FC4179	7/8
FC4180	15/16
FC4181	1
FC4182	1-1/16
FC4183	1-1/8
FC4184	1-3/16
FC4185	1-1/4
FC4186	1-5/16
FC4187	1-3/8
FC4188	1-7/16
FC4189	1-1/2
FC4190	1-9/16
FC4191	1-5/8
FC4192	1-11/16
FC4193	1-3/4
FC4194	1-13/16
FC4195	1-7/8
FC4196	1-15/16
FC4197	2
FC4198	2-1/8
FC4199	2-1/4
FC4200	2-3/8
FC4201	2-1/2
FC4202	2-5/8
FC4203	2-3/4
FC4204	2-7/8
FC4205	3
FC4206	3-1/4
FC4207	3-1/2
FC4208	3-3/4
FC4209	4
FC4210	4-1/4
FC4211	4-1/2
FC4212	4-3/4
FC4213	5
FC4214	5-1/4
FC4215	5-1/2
FC4216	5-3/4
FC4217	6

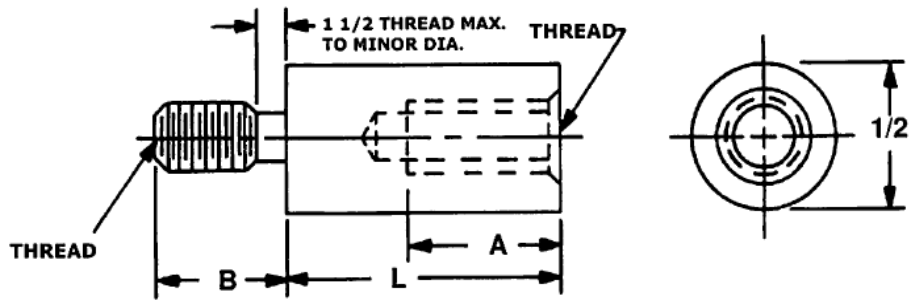

- Contact Sales Office for sizes not shown
- Source Control Drawing: To be produced by Fascomp Electronic Hardware

Create a part number			
FCXXXX	XXXX	XX	XX
Length	Thread	Material	Finish

Thread		
Short lengths, 'A' tapped to maximum depth		
Thread Code (XXX)	Depth (A)	Length (B)
1032	1/2	3/8
1224	1/2	3/8
2520	5/8	1/2
3118	5/8	1/2

Material	
Material Code (XX)	
A	Aluminum
B	Brass
S	Steel
SS	Stainless Steel
N	Nylon

See page 3 for finish codes



Fascomp Electronic Hardware
 7814 Kingspointe Pkwy
 Orlando, FL 32819
 www.fascomp.com
 Tel: (407) 226-2
 Fax: (407) 226-2



3/16 Hex Male-Female Standoff

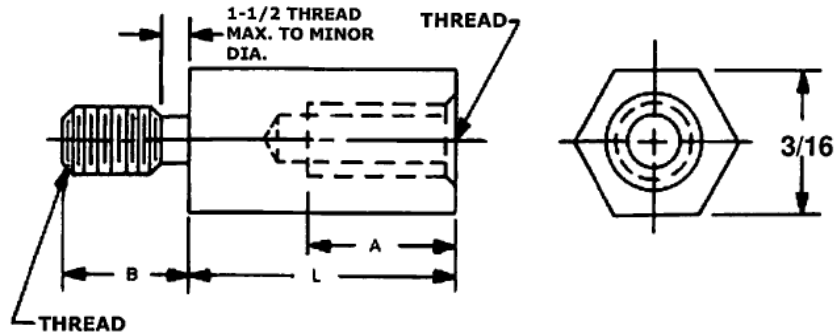

FCXXX	Length (L)
FC4500	3/16
FC4501	1/4
FC4502	5/16
FC4503	3/8
FC4504	7/16
FC4505	1/2
FC4506	9/16
FC4507	5/8
FC4508	11/16
FC4509	3/4
FC4510	13/16
FC4511	7/8
FC4512	15/16
FC4513	1
FC4514	1-1/16
FC4515	1-1/8
FC4516	1-3/16
FC4517	1-1/4
FC4518	1-5/16
FC4519	1-3/8
FC4520	1-7/16
FC4521	1-1/2
FC4522	1-9/16
FC4523	1-5/8
FC4524	1-11/16
FC4525	1-3/4
FC4526	1-13/16
FC4527	1-7/8
FC4528	1-15/16
FC4529	2

- Contact Sales Office for sizes not shown
- Source Control Drawing: To be produced by Fascomp Electronic Hardware

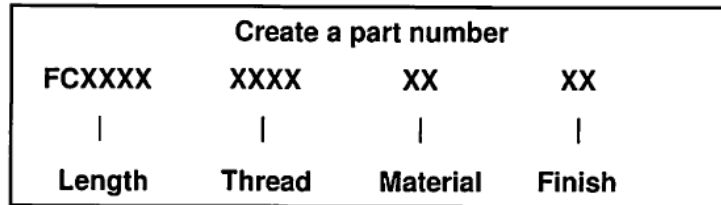

Thread		
Short lengths, 'A' tapped to maximum depth		
Thread Code (XXX)	Depth (A)	Length (B)
256	3/16	5/32
440	1/4	3/16
632	3/8	1/4

Material	
Material Code (XX)	
A	Aluminum
B	Brass
S	Steel
SS	Stainless Steel
N	Nylon

See page 3 for finish codes



Fascomp Electronic Hardware
 7814 Kingspointe Pkwy
 Orlando, FL 32819
 www.fascomp.com
 tel: (407) 226-2111
 fax: (407) 226-3371



Get quote >>

Angic Global Solutions

1-888-872-0690

<https://www.AngicGlobal.com> Sales@AngicGlobal.com

1/4 Hex Male-Female Standoff

FCXXX	Length (L)
FC4530	1/4
FC4531	5/16
FC4532	3/8
FC4533	7/16
FC4534	1/2
FC4535	9/16
FC4536	5/8
FC4537	11/16
FC4538	3/4
FC4539	13/16
FC4540	7/8
FC4541	15/16
FC4542	1
FC4543	1-1/16
FC4544	1-1/8
FC4545	1-3/16
FC4546	1-1/4
FC4547	1-5/16
FC4548	1-3/8
FC4549	1-7/16
FC4550	1-1/2
FC4551	1-9/16
FC4552	1-5/8
FC4553	1-11/16
FC4554	1-3/4
FC4555	1-13/16
FC4556	1-7/8
FC4557	1-15/16
FC4558	2
FC4559	2-1/8
FC4560	2-1/4
FC4561	2-3/8
FC4562	2-1/2
FC4563	2-5/8
FC4564	2-3/4
FC4565	2-7/8
FC4566	3
FC4567	3-1/4
FC4568	3-1/2
FC4569	3-3/4
FC4570	4

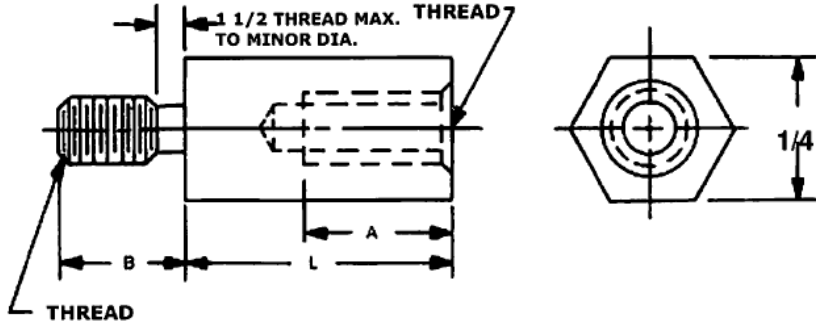

- Contact Sales Office for sizes not shown
- Source Control Drawing: To be produced by Fascomp Electronic Hardware

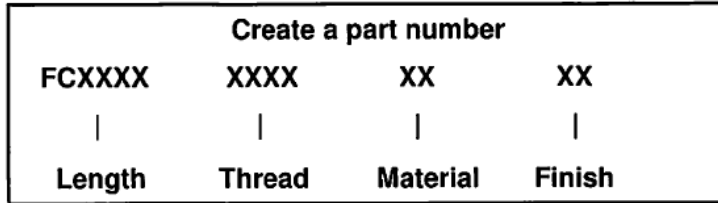

Thread		
Short lengths, 'A' tapped to maximum depth		
Thread Code (XXX)	Depth (A)	Length (B)
256	3/16	5/32
440	1/4	3/16
632	3/8	1/4
832	7/16	3/8

Material	
Material Code (XX)	
A	Aluminum
B	Brass
S	Steel
SS	Stainless Steel
N	Nylon

See page 3 for finish codes



Fascomp Electronic Hardware
 7814 Kingspointe Pkwy
 Orlando, FL 32819
 www.fascomp.com
 Tel: (407) 226-2
 Fax: (407) 226-3



5/16 Hex Male-Female Standoff

FCXXX	Length (L)
FC4571	1/4
FC4572	5/16
FC4573	3/8
FC4574	7/16
FC4575	1/2
FC4576	9/16
FC4577	5/8
FC4578	11/16
FC4579	3/4
FC4580	13/16
FC4581	7/8
FC4582	15/16
FC4583	1
FC4584	1-1/16
FC4585	1-1/8
FC4586	1-3/16
FC4587	1-1/4
FC4588	1-5/16
FC4589	1-3/8
FC4590	1-7/16
FC4591	1-1/2
FC4592	1-9/16
FC4593	1-5/8
FC4594	1-11/16
FC4595	1-3/4
FC4596	1-13/16
FC4597	1-7/8
FC4598	1-15/16
FC4599	2
FC4600	2-1/8
FC4601	2-1/4
FC4602	2-3/8
FC4603	2-1/2
FC4604	2-5/8
FC4605	2-3/4
FC4606	2-7/8
FC4607	3
FC4608	3-1/4
FC4609	3-1/2
FC4610	3-3/4
FC4611	4
FC4612	4-1/4
FC4613	4-1/2
FC4614	4-3/4
FC4615	5
FC4616	5-1/4
FC4617	5-1/2
FC4618	5-3/4
FC4619	6

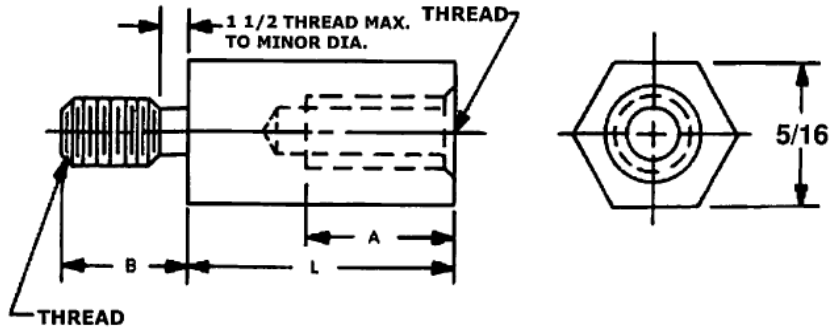

- Contact Sales Office for sizes not shown
- Source Control Drawing: To be produced by Fascomp Electronic Hardware

Create a part number			
FCXXX	XXXX	XX	XX
Length	Thread	Material	Finish

Thread		
Short lengths, 'A' tapped to maximum depth		
Thread Code (XXX)	Depth (A)	Length (B)
440	1/4	3/16
632	3/8	1/4
832	7/16	3/8
1032	1/2	3/8

Material	
Material Code (XX)	
A	Aluminum
B	Brass
S	Steel
SS	Stainless Steel
N	Nylon

See page 3 for finish codes



Fascomp Electronic Hardware
 7814 Kingspointe Pkwy
 Orlando, FL 32819
 www.fascomp.com
 Tel: (407) 226-2
 Fax: (407) 226-3



Get quote >>

Angic Global Solutions

1-888-872-0690

<https://www.AngicGlobal.com> Sales@AngicGlobal.com

3/8 Hex Male-Female Standoff

FCXXXX	Length (L)
FC4620	1/4
FC4621	5/16
FC4622	3/8
FC4623	7/16
FC4624	1/2
FC4625	9/16
FC4626	5/8
FC4627	11/16
FC4628	3/4
FC4629	13/16
FC4630	7/8
FC4631	15/16
FC4632	1
FC4633	1-1/16
FC4634	1-1/8
FC4635	1-3/16
FC4636	1-1/4
FC4637	1-5/16
FC4638	1-3/8
FC4639	1-7/16
FC4640	1-1/2
FC4641	1-9/16
FC4642	1-5/8
FC4643	1-11/16
FC4644	1-3/4
FC4645	1-13/16
FC4646	1-7/8
FC4647	1-15/16
FC4648	2
FC4649	2-1/8
FC4650	2-1/4
FC4651	2-3/8
FC4652	2-1/2
FC4653	2-5/8
FC4654	2-3/4
FC4655	2-7/8
FC4656	3
FC4657	3-1/4
FC4658	3-1/2
FC4659	3-3/4
FC4660	4
FC4661	4-1/4
FC4662	4-1/2
FC4663	4-3/4
FC4664	5
FC4665	5-1/4
FC4666	5-1/2
FC4667	5-3/4
FC4668	6

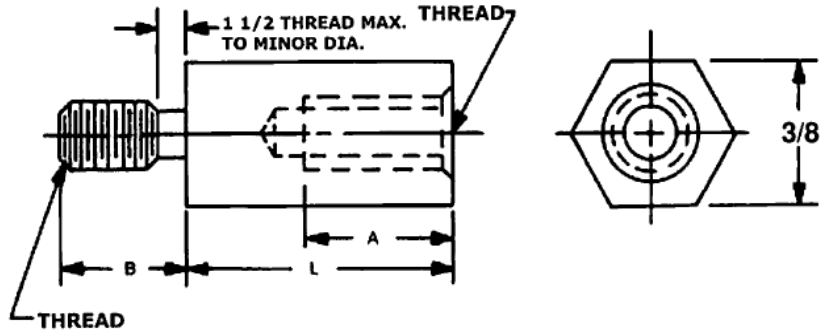

- Contact Sales Office for sizes not shown
- Source Control Drawing: To be produced by Fascomp Electronic Hardware

Create a part number			
FCXXXX	XXXX	XX	XX
Length	Thread	Material	Finish

Thread		
Short lengths, 'A' tapped to maximum depth		
Thread Code (XXX)	Depth (A)	Length (B)
440	1/4	3/16
632	3/8	1/4
832	7/16	3/8
1032	1/2	3/8
1224	1/2	3/8

Material	
Material Code (XX)	
A	Aluminum
B	Brass
S	Steel
SS	Stainless Steel
N	Nylon

See page 3 for finish codes



Fascomp Electronic Hardware
 7814 Kingspointe Pkwy
 Orlando, FL 32819
 www.fascomp.com
 Tel: (407) 226-
 Fax: (407) 226-

Angic Global Solutions

1-888-872-0690

<https://www.AngicGlobal.com> Sales@AngicGlobal.com



1/2 Hex Male-Female Standoff

FCXXX	Length (L)
FC4669	1/4
FC4670	5/16
FC4671	3/8
FC4672	7/16
FC4673	1/2
FC4674	9/16
FC4675	5/8
FC4676	11/16
FC4677	3/4
FC4678	13/16
FC4679	7/8
FC4680	15/16
FC4681	1
FC4682	1-1/16
FC4683	1-1/8
FC4684	1-3/16
FC4685	1-1/4
FC4686	1-5/16
FC4687	1-3/8
FC4688	1-7/16
FC4689	1-1/2
FC4690	1-9/16
FC4691	1-5/8
FC4692	1-11/16
FC4693	1-3/4
FC4694	1-13/16
FC4695	1-7/8
FC4696	1-15/16
FC4697	2
FC4698	2-1/8
FC4699	2-1/4
FC4700	2-3/8
FC4701	2-1/2
FC4702	2-5/8
FC4703	2-3/4
FC4704	2-7/8
FC4705	3
FC4706	3-1/4
FC4707	3-1/2
FC4708	3-3/4
FC4709	4
FC4710	4-1/4
FC4711	4-1/2
FC4712	4-3/4
FC4713	5
FC4714	5-1/4
FC4715	5-1/2
FC4716	5-3/4
FC4717	6

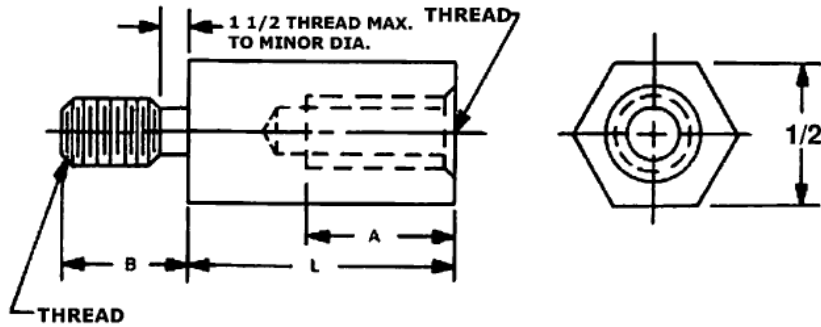

- Contact Sales Office for sizes not shown
- Source Control Drawing: To be produced by Fascomp Electronic Hardware

Create a part number			
FCXXX	XXX	XX	XX
Length	Thread	Material	Finish

Thread		
Short lengths, 'A' tapped to maximum depth		
Thread Code (XXX)	Depth (A)	Length (B)
1032	1/2	3/8
1224	1/2	3/8
2520	5/8	1/2
3118	5/8	1/2

Material	
Material Code (XX)	
A	Aluminum
B	Brass
S	Steel
SS	Stainless Steel
N	Nylon

See page 3 for finish codes



Fascomp Electronic Hardware
 7814 Kingspointe Pkwy
 Orlando, FL 32819
 www.fascomp.com
 Tel: (407) 22-
 Fax: (407) 22-



Get quote >>

Angic Global Solutions

1-888-872-0690

<https://www.AngicGlobal.com> Sales@AngicGlobal.com



Male-Male Standoffs



Fascomp stocks hex Male-Male Standoffs in aluminum, brass, steel, and stainless steel.

Page No.

Hex 133



Fascomp Electronic Hardware
7814 Kingspointe Pkwy
Orlando, FL 32819
www.fascomp.com
Tel: (407) 226-2112
Fax: (407) 226-3370



Get quote >>

Male-Male Hex Standoff

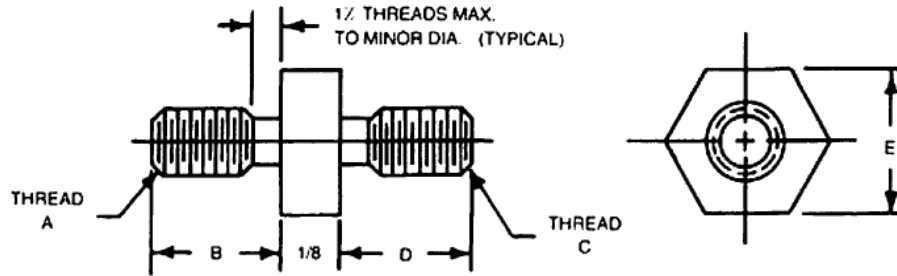

- Contact Sales Office for sizes not shown
- Source Control Drawing: To be produced by Fascomp Electronic Hardware

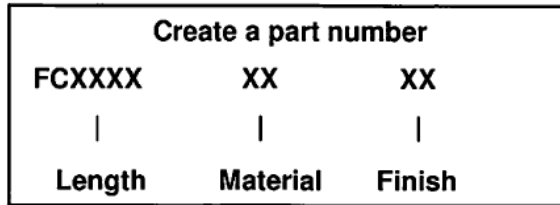

FCXXXX	Thread A	Length B	Thread C	Length D	Hex E
FC4726	440	3/16	440	3/16	1/4
FC4727	440	3/16	632	1/4	1/4
FC4728	632	1/4	632	1/4	1/4
FC4729	632	1/4	832	3/8	1/4
FC4730	832	3/8	832	3/8	1/4
FC4731	832	3/8	1032	3/8	1/4
FC4732	1032	3/8	1032	3/8	1/4
FC4733	832	3/8	832	3/8	5/16
FC4734	832	3/8	1032	3/8	5/16
FC4735	1032	3/8	1032	3/8	5/16

Material	
Material Code (XX)	
A	Aluminum
B	Brass
S	Steel
SS	Stainless Steel

See page 3 for finish codes



Fascomp Electronic Hardware
 7814 Kingspointe Pkwy
 Orlando, FL 32819
 www.fascomp.com
 (407) 226-2112
 (407) 226-3370



Get quote >>

Angic Global Solutions

1-888-872-0690

<https://www.AngicGlobal.com> Sales@AngicGlobal.com



Hex Jackscrews



Fascomp stocks hex Jackscrews in brass, steel, and stainless steel.

Page No.

3/16 Hex 135



Fascomp Electronic Hardware
7814 Kingspointe Pkwy
Orlando, FL 32819
www.fascomp.com
t: (407) 226-2112
x: (407) 226-3370



3/16 Hex Jackscrew

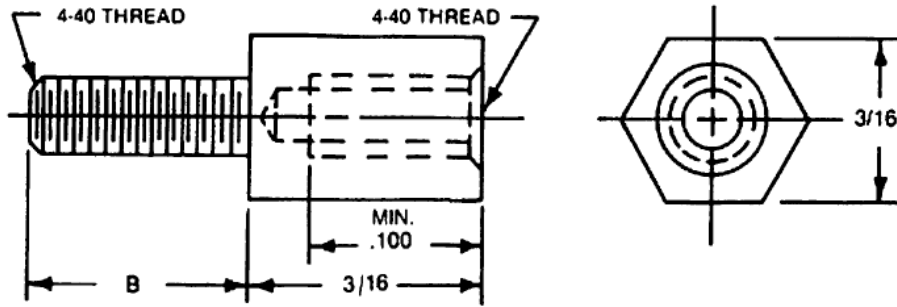

- Contact Sales Office for sizes not shown
- Source Control Drawing: To be produced by Fascomp Electronic Hardware

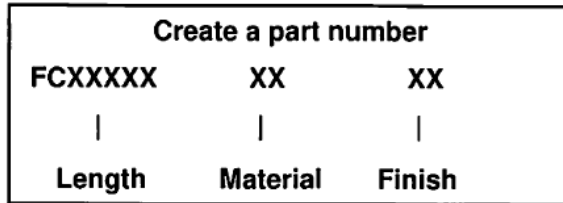

FCXXXXX	Length B
FC47501	3/16
FC47502	1/4
FC47503	5/16
FC47504	3/8
FC47505	7/16
FC47506	1/2
FC47507	9/16
FC47508	5/8
FC47509	11/16
FC47510	3/4

Material	
Material Code (XX)	
B	Brass
S	Steel
SS	Stainless Steel

See page 3 for finish codes



Fascomp Electronic Hardware
 7814 Kingspointe Pkwy
 Orlando, FL 32819
 www.fascomp.com
 407) 226-2112
 407) 226-3370



Get quote >>

Angic Global Solutions 1-888-872-0690
<https://www.AngicGlobal.com> Sales@AngicGlobal.com



Captive Screws Type 6



Fascomp stocks type 6 Captive Screws in aluminum, brass, steel, and stainless steel.

	Page No.
4-40 Thread	137
6-32 Thread	138
8-32 Thread	139
10-32 Thread	140



Fascomp Electronic Hardware
7814 Kingspointe Pkwy
Orlando, FL 32819
www.fascomp.com
Tel: (407) 226-2112
Fax: (407) 226-3370



Captive Screw Type 6 4-40 Thread

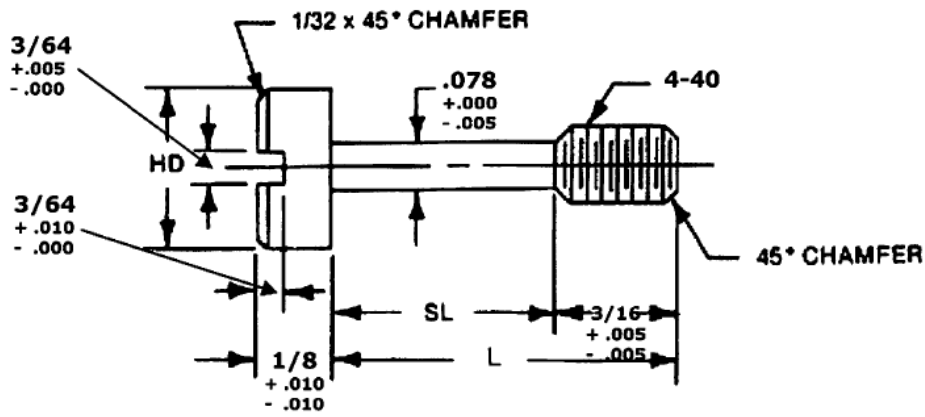

- Contact Sales Office for sizes not shown
- Source Control Drawing: To be produced by Fascomp Electronic Hardware

FCXXX	Length (L)	H.D. +.005 -.005	S.L. +.005 -.000
FC7083	15/32	1/4	9/32
FC7084	17/32	1/4	11/32

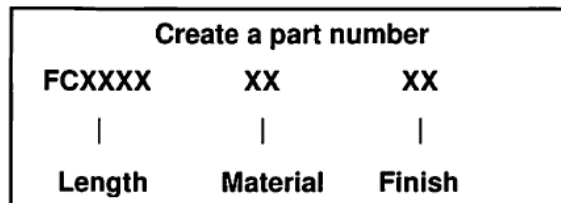

Material	
Material Code (XX)	
B	Brass
S	Steel
SS	Stainless Steel

See page 3 for finish codes



Fascomp Electronic Hardware
 7814 Kingspointe Pkwy
 Orlando, FL 32819
 www.fascomp.com
 Tel: (407) 226-2112
 : (407) 226-3370



Get quote >>

Angic Global Solutions 1-888-872-0690
<https://www.AngicGlobal.com> Sales@AngicGlobal.com

Captive Screw Type 6 6-32 Thread

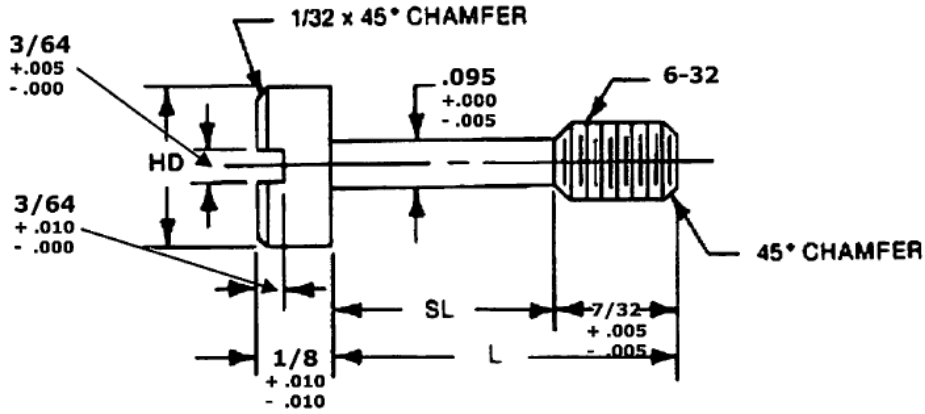

- Contact Sales Office for sizes not shown
- Source Control Drawing: To be produced by Fascomp Electronic Hardware

FCXXX	Length (L)	H.D. +.005 -.005	S.L. +.005 -.000
FC7085	17/32	9/32	5/16
FC7086	19/32	9/32	3/8
FC7087	21/32	9/32	7/16

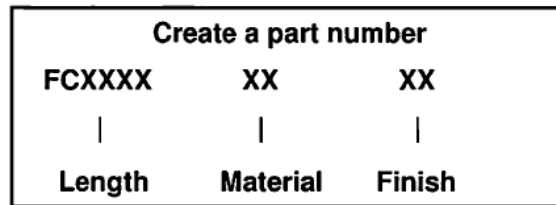

Material	
Material Code (XX)	
B	Brass
S	Steel
SS	Stainless Steel

See page 3 for finish codes



Fascomp Electronic Hardware
 7814 Kingspointe Pkwy
 Orlando, FL 32819
 www.fascomp.com
 Tel: (407) 226-2112
 Fax: (407) 226-3370



Captive Screw Type 6 8-32 Thread

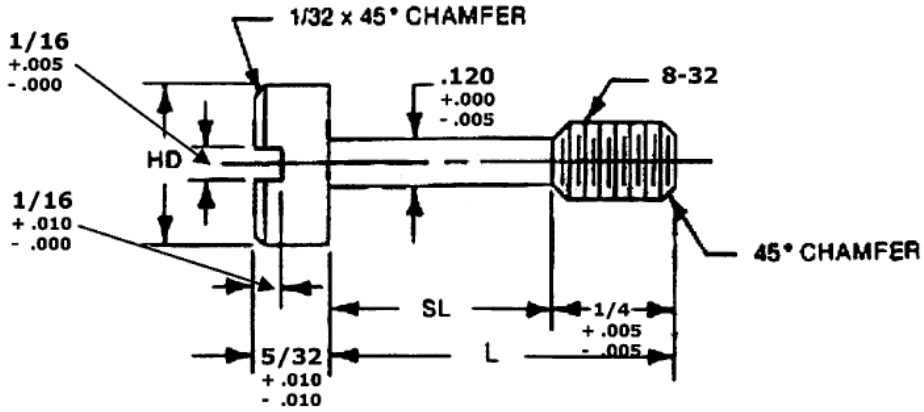

- Contact Sales Office for sizes not shown
- Source Control Drawing: To be produced by Fascomp Electronic Hardware

FCXXX	Length (L)	H.D. +.005 -.005	S.L. +.005 -.000
FC7088	21/32	5/16	13/32
FC7089	23/32	5/16	15/32
FC7090	25/32	5/16	17/32

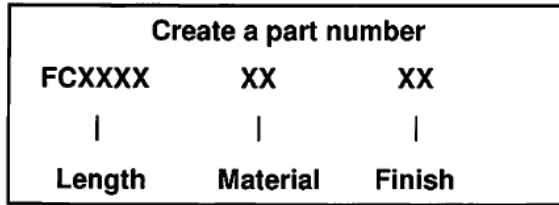

Material	
Material Code (XX)	
B	Brass
S	Steel
SS	Stainless Steel

See page 3 for finish codes



Fascomp Electronic Hardware
 7814 Kingspointe Pkwy
 Orlando, FL 32819
 www.fascomp.com
 (407) 226-2112
 (407) 226-3370



Get quote >>

Angic Global Solutions

1-888-872-0690

<https://www.AngicGlobal.com> Sales@AngicGlobal.com

Captive Screw Type 6 10-32 Thread

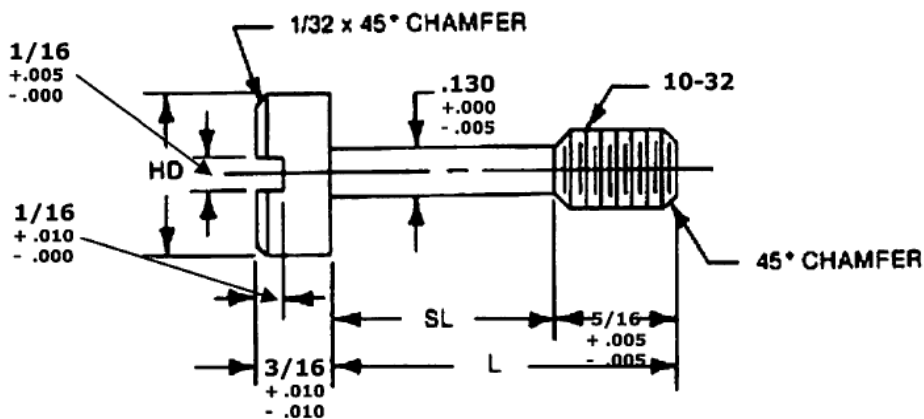

- Contact Sales Office for sizes not shown
- Source Control Drawing: To be produced by Fascomp Electronic Hardware

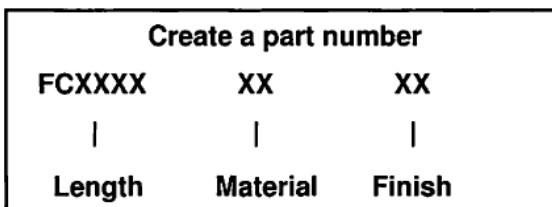

FCXXXX	Length (L)	H.D. +.005 -.005	S.L. +.005 -.000
FC7091	27/32	3/8	17/32
FC7092	29/32	3/8	19/32

Material	
Material Code (XX)	
B	Brass
S	Steel
SS	Stainless Steel

See page 3 for finish codes



Fascomp Electronic Hardware
 7814 Kingspointe Pkwy
 Orlando, FL 32819
 www.fascomp.com
 (407) 226-2112
 (407) 226-3370





Shoulder Screws



Fascomp stocks both Socket Head and Screw Driver Slotted Head Shoulder Screws in brass, steel, and stainless steel.

	Page No.
Socket Head	142
Slotted Head	143



Fascomp Electronic Hardware
7814 Kingspointe Pkwy
Orlando, FL 32819
www.fascomp.com
407) 226-2112
407) 226-3370



Get quote »

Angic Global Solutions 1-888-872-0690
<https://www.AngicGlobal.com> Sales@AngicGlobal.com

Socket Head Shoulder Screw

FCXXX	Thread	A +.004 -.004	B +.000 -.001	C +.010 -.010	D +.002 -.000	E +.005 -.005	F +.002 -.000	G Min.
FC6901	4-40	.250	.1245	.125	.1250	.156	.078	.062
FC6902	4-40	.250	.1245	.125	.1875	.156	.078	.062
FC6903	4-40	.250	.1245	.125	.2500	.156	.078	.062
FC6904	4-40	.250	.1245	.125	.3125	.156	.078	.062
FC6905	4-40	.250	.1245	.125	.3750	.156	.078	.062
FC6906	4-40	.250	.1245	.125	.4375	.156	.078	.062
FC6907	4-40	.250	.1245	.125	.5000	.156	.078	.062
FC6908	6-32	.281	.1560	.125	.1250	.187	.093	.078
FC6909	6-32	.281	.1560	.125	.1875	.187	.093	.078
FC6910	6-32	.281	.1560	.125	.2500	.187	.093	.078
FC6911	6-32	.281	.1560	.125	.3125	.187	.093	.078
FC6912	6-32	.281	.1560	.125	.3750	.187	.093	.078
FC6913	6-32	.281	.1560	.125	.4375	.187	.093	.078
FC6914	6-32	.281	.1560	.125	.5000	.187	.093	.078
FC6915	6-32	.281	.1560	.125	.5625	.187	.093	.078
FC6916	6-32	.281	.1560	.125	.6250	.187	.093	.078
FC6917	6-32	.281	.1560	.125	.6875	.187	.093	.078
FC6918	6-32	.281	.1560	.125	.7500	.187	.093	.078
FC6919	8-32	.312	.187	.156	.1250	.187	.093	.078
FC6920	8-32	.312	.187	.156	.1875	.187	.093	.078
FC6921	8-32	.312	.187	.156	.2500	.187	.093	.078
FC6922	8-32	.312	.187	.156	.3125	.187	.093	.078
FC6923	8-32	.312	.187	.156	.3750	.187	.093	.078
FC6924	8-32	.312	.187	.156	.4375	.187	.093	.078
FC6925	8-32	.312	.187	.156	.5000	.187	.093	.078
FC6926	8-32	.312	.187	.156	.5625	.187	.093	.078
FC6927	8-32	.312	.187	.156	.6250	.187	.093	.078
FC6928	8-32	.312	.187	.156	.6875	.187	.093	.078
FC6929	8-32	.312	.187	.156	.7500	.187	.093	.078
FC6930	8-32	.312	.187	.156	.8750	.187	.093	.078
FC6931	8-32	.312	.187	.156	1.000	.187	.093	.078
FC6932	8-32	.312	.187	.156	1.250	.187	.093	.078
FC6933	8-32	.312	.187	.156	1.375	.187	.093	.078
FC6934	8-32	.312	.187	.156	1.500	.187	.093	.078
FC6935	10-32	.375	.2495	.187	.1250	.250	.125	.093
FC6936	10-32	.375	.2495	.187	.1875	.250	.125	.093
FC6937	10-32	.375	.2495	.187	.2500	.250	.125	.093
FC6938	10-32	.375	.2495	.187	.3125	.250	.125	.093
FC6939	10-32	.375	.2495	.187	.3750	.250	.125	.093
FC6940	10-32	.375	.2495	.187	.4375	.250	.125	.093
FC6941	10-32	.375	.2495	.187	.5000	.250	.125	.093
FC6942	10-32	.375	.2495	.187	.5625	.250	.125	.093
FC6943	10-32	.375	.2495	.187	.6250	.250	.125	.093
FC6944	10-32	.375	.2495	.187	.6875	.250	.125	.093
FC6945	10-32	.375	.2495	.187	.7500	.250	.125	.093
FC6946	10-32	.375	.2495	.187	.8750	.250	.125	.093
FC6947	10-32	.375	.2495	.187	1.000	.250	.125	.093
FC6948	10-32	.375	.2495	.187	1.250	.250	.125	.093
FC6949	10-32	.375	.2495	.187	1.375	.250	.125	.093
FC6950	10-32	.375	.2495	.187	1.500	.250	.125	.093

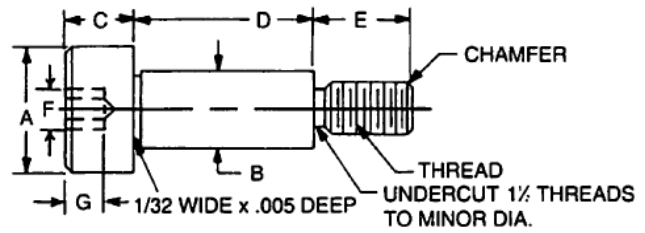

- Contact Sales Office for sizes not shown
- Source Control Drawing: To be produced by Fascomp Electronic Hardware

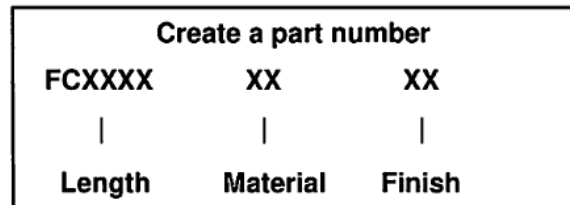

Material	
Material Code (XX)	
B	Brass
S	Steel
SS	Stainless Steel

See page 3 for finish codes



Fascomp Electronic Hardware
7814 Kingspointe Pkwy
Orlando, FL 32819
www.fascomp.com



Slotted Shoulder Screw

FCXXX	Thread	A +.004 -.004	B +.000 -.001	C +.010 -.010	D +.002 -.000	E +.005 -.005
FC7001	4-40	.250	.1245	.125	.1250	.156
FC7002	4-40	.250	.1245	.125	.1875	.156
FC7003	4-40	.250	.1245	.125	.2500	.156
FC7004	4-40	.250	.1245	.125	.3125	.156
FC7005	4-40	.250	.1245	.125	.3750	.156
FC7006	4-40	.250	.1245	.125	.4375	.156
FC7007	4-40	.250	.1245	.125	.5000	.156
FC7008	6-32	.281	.1560	.125	.1250	.187
FC7009	6-32	.281	.1560	.125	.1875	.187
FC7010	6-32	.281	.1560	.125	.2500	.187
FC7011	6-32	.281	.1560	.125	.3125	.187
FC7012	6-32	.281	.1560	.125	.3750	.187
FC7013	6-32	.281	.1560	.125	.4375	.187
FC7014	6-32	.281	.1560	.125	.5000	.187
FC7015	6-32	.281	.1560	.125	.5625	.187
FC7016	6-32	.281	.1560	.125	.6250	.187
FC7017	6-32	.281	.1560	.125	.6875	.187
FC7018	6-32	.281	.1560	.125	.7500	.187
FC7019	8-32	.312	.187	.156	.1250	.187
FC7020	8-32	.312	.187	.156	.1875	.187
FC7021	8-32	.312	.187	.156	.2500	.187
FC7022	8-32	.312	.187	.156	.3125	.187
FC7023	8-32	.312	.187	.156	.3750	.187
FC7024	8-32	.312	.187	.156	.4375	.187
FC7025	8-32	.312	.187	.156	.5000	.187
FC7026	8-32	.312	.187	.156	.5625	.187
FC7027	8-32	.312	.187	.156	.6250	.187
FC7028	8-32	.312	.187	.156	.6875	.187
FC7029	8-32	.312	.187	.156	.7500	.187
FC7030	8-32	.312	.187	.156	.8750	.187
FC7031	8-32	.312	.187	.156	1.000	.187
FC7032	8-32	.312	.187	.156	1.250	.187
FC7033	8-32	.312	.187	.156	1.375	.187
FC7034	8-32	.312	.187	.156	1.500	.187
FC7035	10-32	.375	.2495	.187	.1250	.250
FC7036	10-32	.375	.2495	.187	.1875	.250
FC7037	10-32	.375	.2495	.187	.2500	.250
FC7038	10-32	.375	.2495	.187	.3125	.250
FC7039	10-32	.375	.2495	.187	.3750	.250
FC7040	10-32	.375	.2495	.187	.4375	.250
FC7041	10-32	.375	.2495	.187	.5000	.250
FC7042	10-32	.375	.2495	.187	.5625	.250
FC7043	10-32	.375	.2495	.187	.6250	.250
FC7044	10-32	.375	.2495	.187	.6875	.250
FC7045	10-32	.375	.2495	.187	.7500	.250
FC7046	10-32	.375	.2495	.187	.8750	.250
FC7047	10-32	.375	.2495	.187	1.000	.250
FC7048	10-32	.375	.2495	.187	1.250	.250
FC7049	10-32	.375	.2495	.187	1.375	.250
FC7050	10-32	.375	.2495	.187	1.500	.250

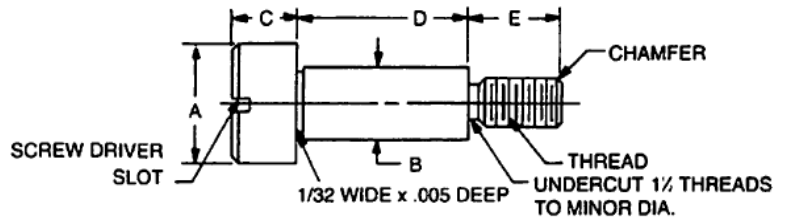

- Contact Sales Office for sizes not shown
- Source Control Drawing: To be produced by Fascomp Electronic Hardware

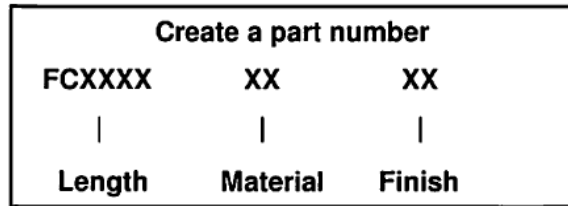

Material	
Material Code (XX)	
B	Brass
S	Steel
SS	Stainless Steel

See page 3 for finish codes



Fascomp Electronic Hardware
7814 Kingspointe Pkwy
Orlando, FL 32819
www.fascomp.com
Tel: (407) 222-2112

Fa: Angic Global Solutions

1-888-872-0690

<https://www.AngicGlobal.com> Sales@AngicGlobal.com



Get quote >>

Thumb Screws & Nuts



Fascomp stocks Washer Face, Push Type and Plain Thumb Screws in aluminum, brass, steel, and stainless steel.

Fascomp also stocks both hex and round Thumb Nuts in aluminum, brass, steel, and stainless steel.

	Page No.
Washer Face	145
Plain	146
Push Type	147
Round Nut	148
Hex Nut	149

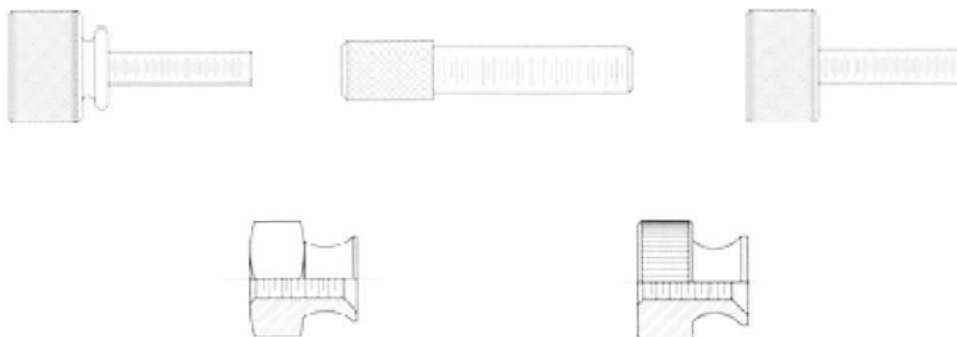

Fascomp Electronic Hardware
 7814 Kingspointe Pkwy
 Orlando, FL 32819
 www.fascomp.com
 Tel: (407) 226-2112
 (407) 226-3370

Washer Face Thumb Screws

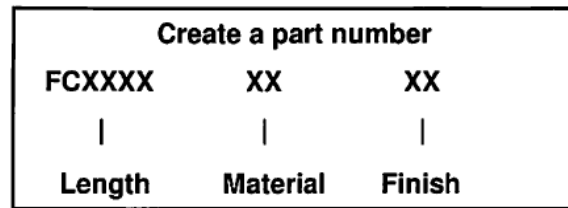
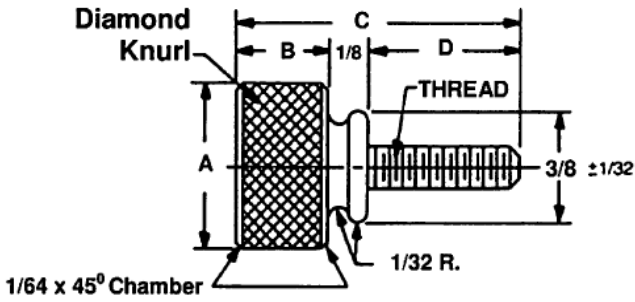

- Contact Sales Office for sizes not shown
- Source Control Drawing: To be produced by Fascomp Electronic Hardware

FCXXX	Thread	A	B	C	D
		+0.020 -0.000	+0.015 -0.015	+0.015 -0.015	+0.010 -0.010
FC7100	4-40	3/8	3/16	5/8	5/16
FC7101	4-40	3/8	3/16	11/16	3/8
FC7102	4-40	3/8	3/16	3/4	7/16
FC7103	6-32	3/8	3/16	11/16	3/8
FC7104	6-32	3/8	3/16	3/4	7/16
FC7105	6-32	3/8	3/16	13/16	1/2
FC7106	8-32	7/16	3/16	11/16	3/8
FC7107	8-32	7/16	3/16	13/16	1/2
FC7108	8-32	7/16	3/16	15/16	5/8
FC7109	10-32	7/16	3/16	11/16	3/8
FC7110	10-32	7/16	3/16	13/16	1/2
FC7111	10-32	7/16	3/16	15/16	5/8
FC7112	1/4-20	1/2	1/4	3/4	3/8
FC7113	1/4-20	1/2	1/4	7/8	1/2
FC7114	1/4-20	1/2	1/4	1	5/8
FC7115	1/4-20	1/2	1/4	1-1/8	3/4

Material	
Material Code (XX)	
A	Aluminum
B	Brass
S	Steel
SS	Stainless Steel

See page 3 for finish codes



Fascomp Electronic Hardware
 7814 Kingspointe Pkwy
 Orlando, FL 32819
 www.fascomp.com
 (407) 226-2112
 (407) 226-3370



Get quote >>

Angic Global Solutions 1-888-872-0690
<https://www.AngicGlobal.com> Sales@AngicGlobal.com

Plain Thumb Screws

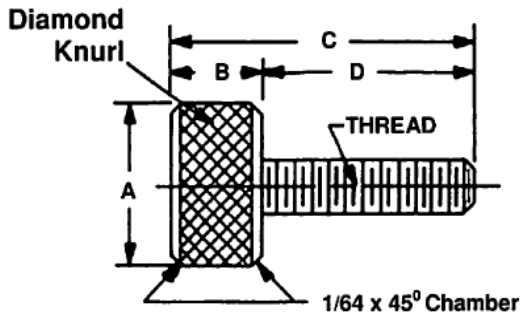

Create a part number		
FCXXXX	XX	XX
Length	Material	Finish

- Contact Sales Office for sizes not shown
- Source Control Drawing: To be produced by Fascomp Electronic Hardware

FCXXXX	Thread	A +.020 -.000	B +.015 -.015	C +.015 -.015	D +.010 -.010
FC7120	4-40	5/16	3/16	1/2	5/16
FC7121	4-40	5/16	3/16	9/16	3/8
FC7122	4-40	5/16	3/16	5/8	7/16
FC7123	4-40	5/16	3/16	11/16	1/2
FC7124	6-32	5/16	3/16	1/2	5/16
FC7125	6-32	5/16	3/16	9/16	3/8
FC7126	6-32	5/16	3/16	5/8	7/16
FC7127	6-32	5/16	3/16	11/16	1/2
FC7128	8-32	3/8	3/16	9/16	3/8
FC7129	8-32	3/8	3/16	5/8	7/16
FC7130	8-32	3/8	3/16	11/16	1/2
FC7131	8-32	3/8	3/16	3/4	9/16
FC7132	8-32	3/8	3/16	13/16	5/8
FC7133	10-32	7/16	3/16	9/16	3/8
FC7134	10-32	7/16	3/16	5/8	7/16
FC7135	10-32	7/16	3/16	11/16	1/2
FC7136	10-32	7/16	3/16	3/4	9/16
FC7137	10-32	7/16	3/16	13/16	5/8
FC7138	1/4-20	1/2	1/4	3/4	1/2
FC7139	1/4-20	1/2	1/4	13/16	9/16
FC7140	1/4-20	1/2	1/4	7/8	5/8
FC7141	1/4-20	1/2	1/4	15/16	11/16
FC7142	1/4-20	1/2	1/4	1	3/4

Material	
Material Code (XX)	
A	Aluminum
B	Brass
S	Steel
SS	Stainless Steel

See page 3 for finish codes



Fascomp Electronic Hardware
7814 Kingspointe Pkwy
Orlando, FL 32819
www.fascomp.com



Get quote >>

Push Type Thumb Screws

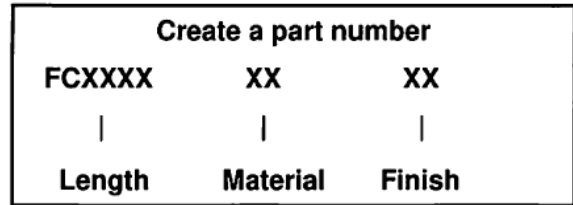
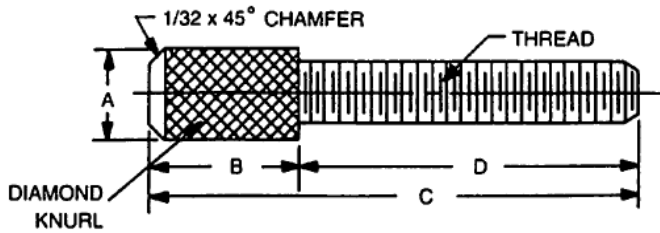

- Contact Sales Office for sizes not shown
- Source Control Drawing: To be produced by Fascomp Electronic Hardware

FCXXXX	Thread	A +.020 -.000	B +.015 -.015	C +.015 -.015	D +.010 -.010
FC7150	6-32	3/16	3/8	1	5/8
FC7151	6-32	3/16	3/8	1-1/8	3/4
FC7152	6-32	3/16	3/8	1-1/4	7/8
FC7153	6-32	3/16	3/8	1-3/8	1
FC7154	6-32	3/16	3/8	1-1/2	1-1/8
FC7155	6-32	3/16	3/8	1-5/8	1-1/4
FC7156	6-32	3/16	3/8	1-3/4	1-3/8
FC7157	6-32	3/16	3/8	1-7/8	1-1/2
FC7158	6-32	3/16	3/8	2	1-5/8
FC7159	6-32	3/16	3/8	2-1/8	1-3/4
FC7160	6-32	3/16	3/8	2-1/4	1-7/8
FC7161	6-32	3/16	3/8	2-3/8	2
FC7162	8-32	3/16	3/8	1	5/8
FC7163	8-32	3/16	3/8	1-1/8	3/4
FC7164	8-32	3/16	3/8	1-1/4	7/8
FC7165	8-32	3/16	3/8	1-3/8	1
FC7166	8-32	3/16	3/8	1-1/2	1-1/8
FC7167	8-32	3/16	3/8	1-5/8	1-1/4
FC7168	8-32	3/16	3/8	1-3/4	1-3/8
FC7169	8-32	3/16	3/8	1-7/8	1-1/2
FC7170	8-32	3/16	3/8	2	1-5/8
FC7171	8-32	3/16	3/8	2-1/8	1-3/4
FC7172	8-32	3/16	3/8	2-1/4	1-7/8
FC7173	8-32	3/16	3/8	2-3/8	2
FC7174	10-24	1/4	1/2	1-1/8	5/8
FC7175	10-24	1/4	1/2	1-1/4	3/4
FC7176	10-24	1/4	1/2	1-3/8	7/8
FC7177	10-24	1/4	1/2	1-1/2	1
FC7178	10-24	1/4	1/2	1-5/8	1-1/8
FC7179	10-24	1/4	1/2	1-3/4	1-1/4
FC7180	10-24	1/4	1/2	1-7/8	1-3/8
FC7181	10-24	1/4	1/2	2	1-1/2
FC7182	10-24	1/4	1/2	2-1/8	1-5/8
FC7183	10-24	1/4	1/2	2-1/4	1-3/4
FC7184	10-24	1/4	1/2	2-3/8	1-7/8
FC7185	10-24	1/4	1/2	2-1/2	2
FC7186	10-32	1/4	1/2	1-1/8	5/8
FC7187	10-32	1/4	1/2	1-1/4	3/4
FC7188	10-32	1/4	1/2	1-3/8	7/8
FC7189	10-32	1/4	1/2	1-1/2	1
FC7190	10-32	1/4	1/2	1-5/8	1-1/8

FCXXXX	Thread	A +.020 -.000	B +.015 -.015	C +.015 -.015	D +.010 -.010
FC7191	10-32	1/4	1/2	1-3/4	1-1/4
FC7192	10-32	1/4	1/2	1-7/8	1-3/8
FC7193	10-32	1/4	1/2	2	1-1/2
FC7194	10-32	1/4	1/2	2-1/8	1-5/8
FC7195	10-32	1/4	1/2	2-1/4	1-3/4
FC7196	10-32	1/4	1/2	2-3/8	1-7/8
FC7197	10-32	1/4	1/2	2-1/2	2
FC7198	1/4-20	5/16	1/2	1-1/8	5/8
FC7199	1/4-20	5/16	1/2	1-1/4	3/4
FC7200	1/4-20	5/16	1/2	1-3/8	7/8
FC7201	1/4-20	5/16	1/2	1-1/2	1
FC7202	1/4-20	5/16	1/2	1-5/8	1-1/8
FC7203	1/4-20	5/16	1/2	1-3/4	1-1/4
FC7204	1/4-20	5/16	1/2	1-7/8	1-3/8
FC7205	1/4-20	5/16	1/2	2	1-1/2
FC7206	1/4-20	5/16	1/2	2-1/8	1-5/8
FC7207	1/4-20	5/16	1/2	2-1/4	1-3/4
FC7208	1/4-20	5/16	1/2	2-3/8	1-7/8
FC7209	1/4-20	5/16	1/2	2-1/2	2

Material	
Material Code (XX)	
A	Aluminum
B	Brass
S	Steel
SS	Stainless Steel

See page 3 for finish codes



Fascomp Electronic Hardware
 7814 Kingspointe Pkwy
 Orlando, FL 32819
 www.fascomp.com
 Tel: (407) 2
 Fax: (407) 2

Angic Global Solutions 1-888-872-0690
<https://www.AngicGlobal.com> Sales@AngicGlobal.com



Get quote >>

Round Thumb Nut

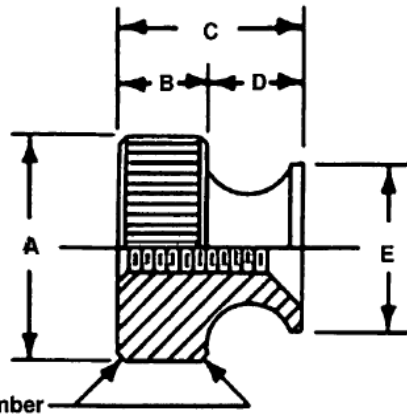

Create a part number		
FCXXXX	XX	XX
Length	Material	Finish

1/64 x 45° Chamber

- Contact Sales Office for sizes not shown
- Source Control Drawing: To be produced by Fascomp Electronic Hardware

FCXXXX	Thread	A +.020 -.020	B +.015 -.015	C Ref	D +.010 -.010	E +.031 -.031
FC7210	2-56	1/4	1/8	1/4	1/8	3/16
FC7211	4-40	5/16	1/8	1/4	1/8	1/4
FC7212	6-32	3/8	1/8	9/32	5/32	11/32
FC7213	8-32	7/16	1/8	9/32	5/32	3/8
FC7214	10-24	1/2	5/32	11/32	3/16	13/32
FC7215	10-32	1/2	5/32	11/32	3/16	13/32
FC7216	1/4-20	9/16	5/32	3/8	7/32	15/32
FC7217	5/16-18	5/8	3/16	13/32	7/32	17/32
FC7218	3/8-16	3/4	7/32	15/32	1/4	5/8

Material	
Material Code (XX)	
A	Aluminum
B	Brass
S	Steel
SS	Stainless Steel

See page 3 for finish codes



Fascomp Electronic Hardware
7814 Kingspointe Pkwy
Orlando, FL 32819
www.fascomp.com
(407) 226-2112
(407) 226-3370



Hex Thumb Nut

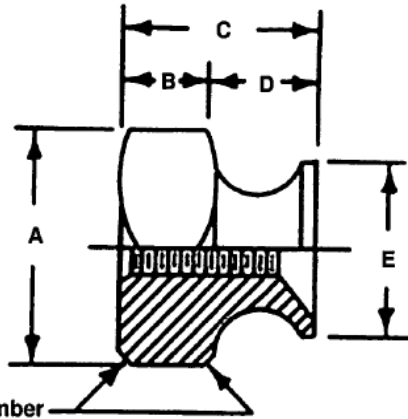

1/64 x 45° Chamber

Create a part number		
FCXXXX	XX	XX
Length	Material	Finish

- Contact Sales Office for sizes not shown
- Source Control Drawing: To be produced by Fascomp Electronic Hardware

FCXXXX	Thread	A +.020 -.020	B +.015 -.015	C Ref	D +.010 -.010	E +.031 -.031
FC7219	2-56	1/4	1/8	1/4	1/8	3/16
FC7220	4-40	5/16	1/8	1/4	1/8	1/4
FC7221	6-32	3/8	1/8	9/32	5/32	11/32
FC7222	8-32	7/16	1/8	9/32	5/32	3/8
FC7223	10-24	1/2	5/32	11/32	3/16	13/32
FC7224	10-32	1/2	5/32	11/32	3/16	13/32
FC7225	1/4-20	9/16	5/32	3/8	7/32	15/32
FC7226	5/16-18	5/8	3/16	13/32	7/32	17/32
FC7227	3/8-16	3/4	7/32	15/32	1/4	5/8

Material	
Material Code (XX)	
A	Aluminum
B	Brass
S	Steel
SS	Stainless Steel

See page 3 for finish codes



Fascomp Electronic Hardware
7814 Kingspointe Pkwy
Orlando, FL 32819
www.fascomp.com
(407) 226-2112
(407) 226-3370



Get quote >>

Angic Global Solutions

1-888-872-0690

<https://www.AngicGlobal.com> Sales@AngicGlobal.com



Chassis Fasteners

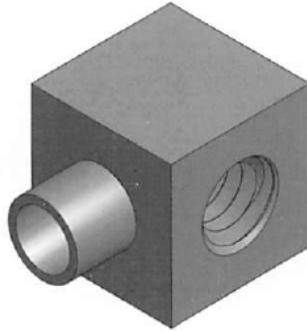

	Page No.
4-40 Thread	151
6-32 Thread	152



Fascomp Electronic Hardware
7814 Kingspointe Pkwy
Orlando, FL 32819
www.fascomp.com
Tel: (407) 226-2117
Fax: (407) 226-3377

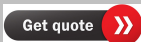

Chassis Fastener — 4-40 Thread

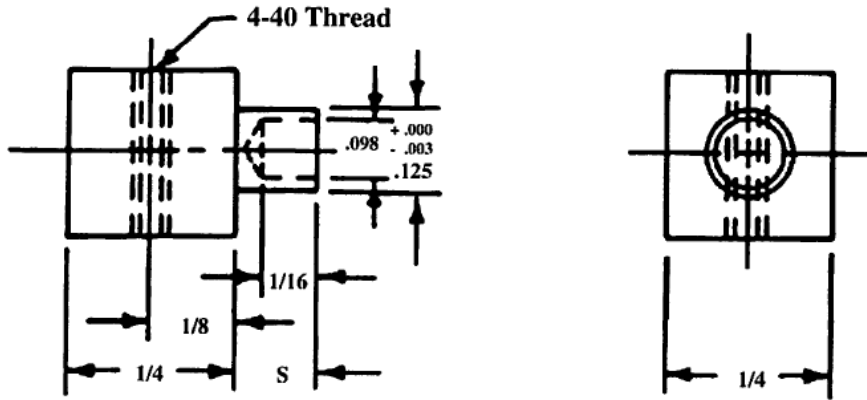

- Contact Sales Office for sizes not shown
- Source Control Drawing: To be produced by Fascomp Electronic Hardware

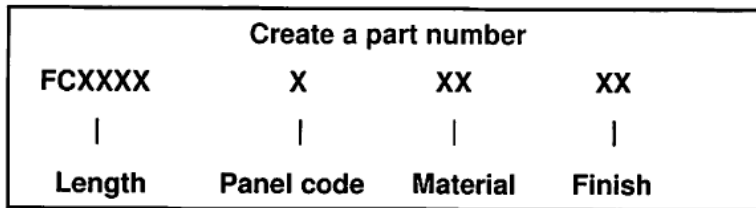

FCXXXX	Length (L)	Thread
FC7228	1/4	4-40

Swage Panel/Code (X)		
S	+ .003 - .003	P
A	.075	1/32
B	.105	1/16
C	.135	3/32
D	.165	1/8

Material	
Material Code (XX)	
A	Aluminum
B	Brass
S	Steel
SS	Stainless Steel

See page 3 for finish codes



Fascomp Electronic Hardware
 7814 Kingspointe Pkwy
 Orlando, FL 32819
 www.fascomp.com
 (407) 226-2112
 (407) 226-3370



Get quote >>

Angic Global Solutions 1-888-872-0690
<https://www.AngicGlobal.com> Sales@AngicGlobal.com

Chassis Fastener — 6-32 Thread

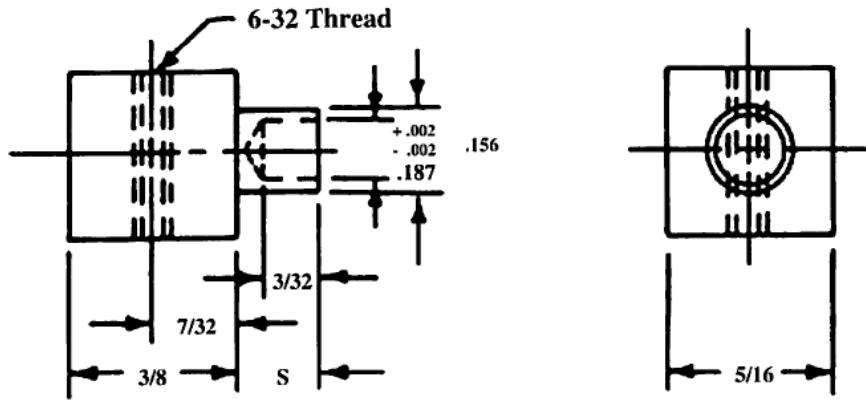

- Contact Sales Office for sizes not shown
- Source Control Drawing: To be produced by Fascomp Electronic Hardware

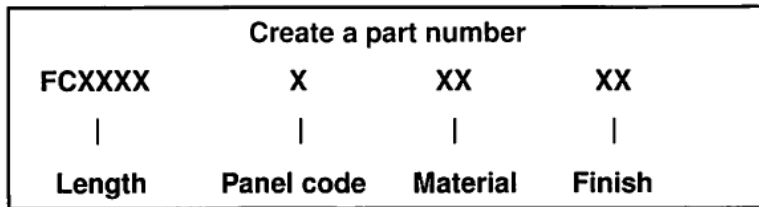

FCXXX	Length (L)	Thread
FC7229	3/8	6-32

Swage Panel/Code (X)		
S	+ .003 - .003	P
A	.075	1/32
B	.105	1/16
C	.135	3/32
D	.165	1/8

Material	
Material Code (XX)	
A	Aluminum
B	Brass
S	Steel
SS	Stainless Steel

See page 3 for finish codes



Fascomp Electronic Hardware
 7814 Kingspointe Pkwy
 Orlando, FL 32819
 www.fascomp.com
 Tel: (407)
 226-2112





Handles



Fascomp stocks Round, Round Off-Set and Oval Handles in aluminum, brass, and stainless steel.

	Page No.
Round	154
Round Off-Set	161
Oval	166



Fascomp Electronic Hardware
7814 Kingspointe Pkwy
Orlando, FL 32819
www.fascomp.com
Tel: (407)
226-2112



Get quote »

Angic Global Solutions 1-888-872-0690
<https://www.AngicGlobal.com> Sales@AngicGlobal.com



Round Internal Thread Handles



Fascomp stocks Round Internal Thread Handles in aluminum, brass, and stainless steel.

Page No.

1/8 Handle Size	155
5/32 Handle Size	156
3/16 Handle Size	157
1/4 Handle Size	158
5/16 Handle Size	159
3/8 Handle Size	160



Fascomp Electronic Hardware
7814 Kingspointe Pkwy
Orlando, FL 32819
www.fascomp.com
Tel: (407)
226-2112

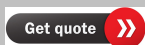

1/8 Round Internal Thread Handles

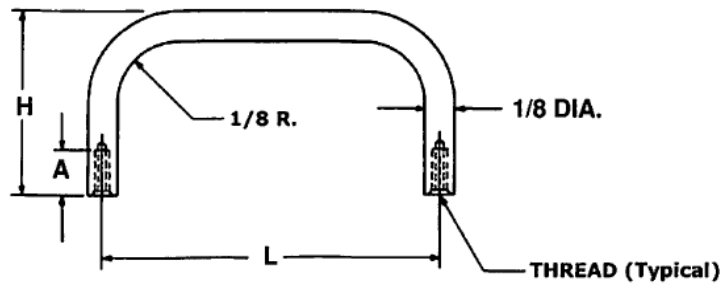

- Contact Sales Office for sizes not shown
- Source Control Drawing: To be produced by Fascomp Electronic Hardware

FCXXXX	Length (L) +/- .031	Leg Height (H) +/- .031
FC8000	3/4	1/2
FC8001	13/16	1/2
FC8002	7/8	1/2
FC8003	1	1/2
FC8004	1-1/4	1/2
FC8005	1-1/2	1/2
FC8006	2	1/2
FC8007	3/4	3/4
FC8008	13/16	3/4
FC8009	7/8	3/4
FC8010	1	3/4
FC8011	1-1/4	3/4
FC8012	1-1/2	3/4
FC8013	2	3/4
FC8014	1	1
FC8015	1-1/4	1
FC8016	1-1/2	1
FC8017	1-3/4	1
FC8018	2	1
FC8019	1	1-1/4
FC8020	1-1/4	1-1/4
FC8021	1-1/2	1-1/4
FC8022	1-3/4	1-1/4
FC8023	2	1-1/4
FC8024	1	1-1/2
FC8025	1-1/4	1-1/2
FC8026	1-1/2	1-1/2
FC8027	1-3/4	1-1/2
FC8028	2	1-1/2
FC8029	1-1/4	2
FC8030	1-1/2	2
FC8031	1-3/4	2
FC8032	2	2
FC8033	2-1/2	2
FC8034	3	2

Create a part number			
FCXXXX	XXX	XX	XX
Length	Thread	Material	Finish

Thread (A)		
Short lengths, 'A' tapped to maximum depth		
Code (XXX)	Thread	(A)
256	2-56	3/16

Material	
Material Code (XX)	
A	Aluminum
B	Brass
SS	Stainless Steel

See page 3 for finish codes



Fascomp Electronic Hardware
 7814 Kingspointe Pkwy
 Orlando, FL 32819
 www.fascomp.com
 tel: (407) 226-211
 fax: (407) 226-337



Get quote >>

Angic Global Solutions

1-888-872-0690

<https://www.AngicGlobal.com> Sales@AngicGlobal.com

5/32 Round Internal Thread Handles

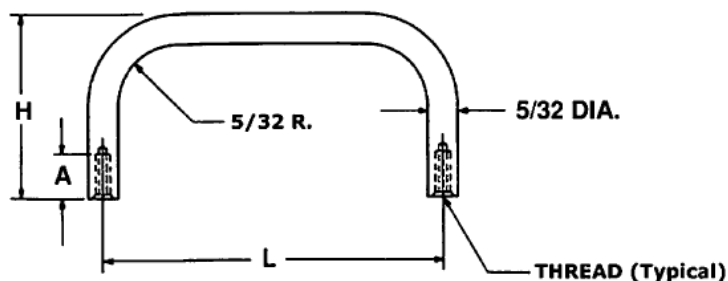

- Contact Sales Office for sizes not shown
- Source Control Drawing: To be produced by Fascomp Electronic Hardware

Create a part number			
FCXXXX	XXX	XX	XX
Length	Thread	Material	Finish

FCXXXX	Length (L) +/- .031	Leg Height (H) +/- .031
FC8035	1	3/4
FC8036	1-1/4	3/4
FC8037	1-1/2	3/4
FC8038	2	3/4
FC8039	2-1/2	3/4
FC8040	3	3/4
FC8041	1	1
FC8042	1-1/4	1
FC8043	1-1/2	1
FC8044	1-3/4	1
FC8045	2	1
FC8046	2-1/2	1
FC8047	3	1

Thread (A)
Short lengths, 'A' tapped to maximum depth

Code (XXX)	Thread	(A)
256	2-56	3/16
440	4-40	1/4 - 3/8

Material	
Material Code (XX)	
A	Aluminum
B	Brass
SS	Stainless Steel

See page 3 for finish codes



Fascomp Electronic Hardware
7814 Kingspointe Pkwy
Orlando, FL 32819
www.fascomp.com
(407) 226-2112
(407) 226-3370

3/16 Round Internal Thread Handles

FCXXXX	Length (L) +/- .031	Leg Height (H) +/- .031
FC8048	1-1/2	5/8
FC8049	1-3/4	5/8
FC8050	2	5/8
FC8051	3	5/8
FC8052	4	5/8
FC8053	5	5/8
FC8054	1	3/4
FC8055	1-1/4	3/4
FC8056	1-1/2	3/4
FC8057	1-3/4	3/4
FC8058	2	3/4
FC8059	3	3/4
FC8060	4	3/4
FC8061	5	3/4
FC8062	1	7/8
FC8063	1-1/4	7/8
FC8064	1-1/2	7/8
FC8065	1-3/4	7/8
FC8066	2	7/8
FC8067	3	7/8
FC8068	4	7/8
FC8069	5	7/8
FC8070	1	1
FC8071	1-1-4	1
FC8072	1-1/2	1
FC8073	1-3/4	1
FC8074	2	1
FC8075	3	1
FC8076	4	1
FC8077	5	1
FC8078	1	1-1/8
FC8079	1-1/4	1-1/8
FC8080	1-1/2	1-1/8
FC8081	1-3/4	1-1/8
FC8082	2	1-1/8
FC8083	3	1-1/8
FC8084	4	1-1/8
FC8085	5	1-1/8
FC8086	1	1-1/4
FC8087	1-1/4	1-1/4
FC8088	1-1/2	1-1/4
FC8089	1-3/4	1-1/4
FC8090	2	1-1/4
FC8091	3	1-1/4
FC8092	4	1-1/4
FC8093	5	1-1/4
FC8094	1	1-1/2
FC8095	1-1/4	1-1/2
FC8096	1-1/2	1-1/2
FC8097	1-3/4	1-1/2
FC8098	2	1-1/2
FC8099	3	1-1/2
FC8100	4	1-1/2
FC8101		

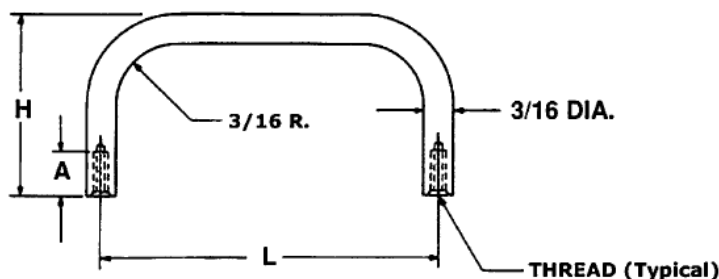

- Contact Sales Office for sizes not shown
- Source Control Drawing: To be produced by Fascomp Electronic Hardware

Create a part number			
FCXXXX	XXX	XX	XX
Length	Thread	Material	Finish

Thread (A)		
Short lengths, 'A' tapped to maximum depth		
Code (XXX)	Thread	(A)
440	4-40	1/4
632	6-32	5/16 - 3/8

Material	
Material Code (XX)	
A	Aluminum
B	Brass
SS	Stainless Steel

See page 3 for finish codes



Fascomp Electronic Hardware
7814 Kingspointe Pkwy
Orlando, FL 32819
www.fascomp.com
Tel: (407) 226-
Fax: (407) 226-



Get quote >>

Angic Global Solutions 1-888-872-0690
<https://www.AngicGlobal.com> Sales@AngicGlobal.com

1/4 Round Internal Thread Handles

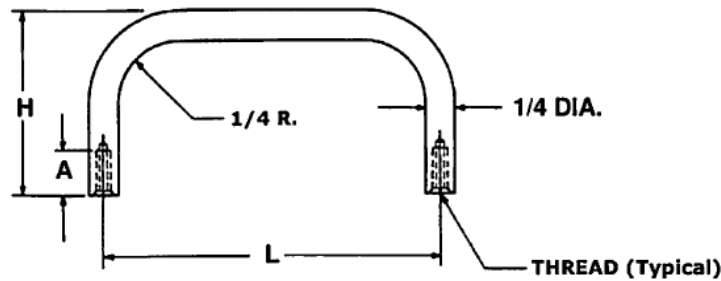

- Contact Sales Office for sizes not shown
- Source Control Drawing: To be produced by Fascomp Electronic Hardware

FCXXXX	Length (L) +/- .031	Leg Height (H) +/- .031
FC8102	1-1/8	1
FC8103	1-1/4	1
FC8104	1-1/2	1
FC8105	1-3/4	1
FC8106	2	1
FC8107	2-1/4	1
FC8108	2-1/2	1
FC8109	2-3/4	1
FC8110	3	1
FC8111	4	1
FC8112	5	1
FC8113	1-1/2	1-1/4
FC8114	1-3/4	1-1/4
FC8115	2	1-1/4
FC8116	2-1/4	1-1/4
FC8117	2-1/2	1-1/4
FC8118	2-3/4	1-1/4
FC8119	3	1-1/4
FC8120	4	1-1/4
FC8121	5	1-1/4
FC8122	1-1/2	1-1/2
FC8123	1-3/4	1-1/2
FC8124	2	1-1/2
FC8125	2-1/4	1-1/2
FC8126	2-1/2	1-1/2
FC8127	2-3/4	1-1/2
FC8128	3	1-1/2
FC8129	3-1/2	1-1/2
FC8130	4	1-1/2
FC8131	4-1/4	1-1/2
FC8132	4-1/2	1-1/2
FC8133	5	1-1/2
FC8134	6	1-1/2
FC8135	3	2
FC8136	4	2
FC8137	5	2
FC8138	6	2

Create a part number			
FCXXXX	XXX	XX	XX
Length	Thread	Material	Finish

Thread (A)		
Short lengths, 'A' tapped to maximum depth		
Code (XXX)	Thread	(A)
632	6-32	3/8
832	8-32	7/16 - 9/16

Material	
Material Code (XX)	
A	Aluminum
B	Brass
SS	Stainless Steel

See page 3 for finish codes



Fascomp Electronic Hardware
 7814 Kingspointe Pkwy
 Orlando, FL 32819
 www.fascomp.com
 tel: (407) 226-2111
 fax: (407) 226-3377

FCXXXX	Length (L) +/- .031	Leg Height (H) +/- .031
FC8139	2	1
FC8140	2-1/2	1
FC8141	3	1
FC8142	3-1/2	1
FC8143	4	1
FC8144	4-1/4	1
FC8145	4-1/2	1
FC8146	5	1
FC8147	6	1
FC8148	2	1-1/8
FC8149	3	1-1/8
FC8150	4	1-1/8
FC8151	4-1/4	1-1/8
FC8152	4-9/16	1-1/8
FC8153	2	1-1/4
FC8154	2-1/2	1-1/4
FC8155	3	1-1/4
FC8156	3-1/2	1-1/4
FC8157	4	1-1/4
FC8158	2	1-5/16
FC8159	2-1/4	1-5/16
FC8160	2-1/2	1-5/16
FC8161	2-3/4	1-5/16
FC8162	2-13/16	1-5/16
FC8163	3	1-5/16
FC8164	4	1-5/16
FC8165	4-1/4	1-5/16
FC8166	2	1-3/8
FC8167	2-1/2	1-3/8
FC8168	3	1-3/8
FC8169	4	1-3/8
FC8170	4-1/4	1-3/8
FC8171	5	1-3/8
FC8172	2	1-1/2
FC8173	2-1/8	1-1/2
FC8174	2-1/4	1-1/2
FC8175	2-3/8	1-1/2
FC8176	2-1/2	1-1/2
FC8177	2-3/4	1-1/2
FC8178	3	1-1/2
FC8179	3-1/8	1-1/2
FC8180	3-1/4	1-1/2
FC8181	3-1/2	1-1/2
FC8182	4	1-1/2
FC8183	4-1/4	1-1/2
FC8184	4-1/2	1-1/2
FC8185	4-9/16	1-1/2
FC8186	4-5/8	1-1/2
FC8187	5	1-1/2
FC8188	5-1/4	1-1/2

5/16 Round Internal Thread Handles

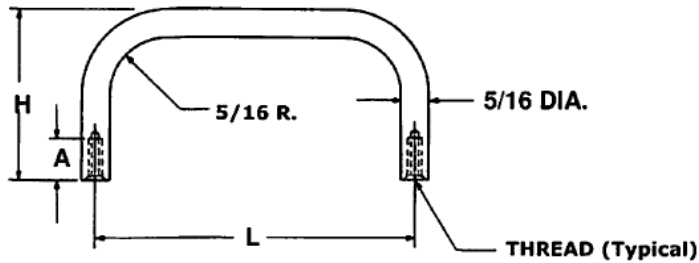

- Contact Sales Office for sizes not shown
- Source Control Drawing: To be produced by Fascomp Electronic Hardware

FCXXXX	Length (L) +/- .031	Leg Height (H) +/- .031
FC8189	5-1/2	1-1/2
FC8190	5-3/4	1-1/2
FC8191	6	1-1/2
FC8192	6-7/16	1-1/2
FC8193	6-1/2	1-1/2
FC8194	7	1-1/2
FC8195	3	1-3/4
FC8196	3-1/2	1-3/4
FC8197	4	1-3/4
FC8198	4-1/4	1-3/4
FC8199	4-1/2	1-3/4
FC8200	4-9/16	1-3/4
FC8201	4-5/8	1-3/4
FC8202	4-3/4	1-3/4
FC8203	5	1-3/4
FC8204	5-1/8	1-3/4
FC8205	5-1/4	1-3/4
FC8206	5-1/2	1-3/4
FC8207	5-3/4	1-3/4
FC8208	6	1-3/4
FC8209	6-1/4	1-3/4
FC8210	6-7/16	1-3/4
FC8211	6-1/2	1-3/4
FC8212	6-3/4	1-3/4
FC8213	7	1-3/4

Create a part number			
FCXXXX	XXX	XX	XX
Length	Thread	Material	Finish

Thread (A)

Short lengths, 'A' tapped to maximum depth

Code (XXX)	Thread	(A)
832	8-32	7/16
1032	10-32	5/16 - 5/8

Material	
Material Code (XX)	
A	Aluminum
B	Brass
SS	Stainless Steel

See page 3 for finish codes



Fascomp Electronic Hardware
7814 Kingspointe Pkwy
Orlando, FL 32819
www.fascomp.com
Tel: (407) 226-2111
Fax: (407) 226-3333



Get quote >>

Angic Global Solutions

1-888-872-0690

<https://www.AngicGlobal.com> Sales@AngicGlobal.com

3/8 Round Internal Thread Handles

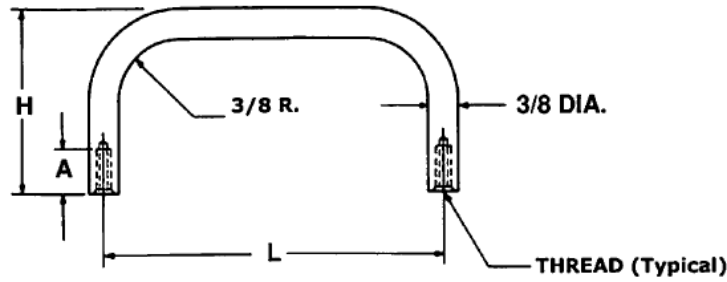

- Contact Sales Office for sizes not shown
- Source Control Drawing: To be produced by Fascomp Electronic Hardware

FCXXXX	Length (L) +/- .031	Leg Height (H) +/- .031
FC8214	2	1-5/16
FC8215	3	1-5/16
FC8216	4	1-5/16
FC8217	5	1-5/16
FC8218	6	1-5/16
FC8219	7	1-5/16
FC8220	2-1/2	1-1/2
FC8221	3	1-1/2
FC8222	4	1-1/2
FC8223	4-1/4	1-1/2
FC8224	4-1/2	1-1/2
FC8225	5	1-1/2
FC8226	6	1-1/2
FC8227	7	1-1/2
FC8228	2	1-3/4
FC8229	2-1/2	1-3/4
FC8230	3	1-3/4
FC8231	3-1/2	1-3/4
FC8232	4	1-3/4
FC8233	4-1/4	1-3/4
FC8234	4-1/2	1-3/4
FC8235	5	1-3/4
FC8236	5-1/4	1-3/4
FC8237	5-1/2	1-3/4
FC8238	5-3/4	1-3/4
FC8239	6	1-3/4
FC8240	6-1/2	1-3/4
FC8241	7	1-3/4
FC8242	3	1-7/8
FC8243	4	1-7/8
FC8244	4-1/4	1-7/8
FC8245	4-1/2	1-7/8
FC8246	5	1-7/8
FC8247	6	1-7/8

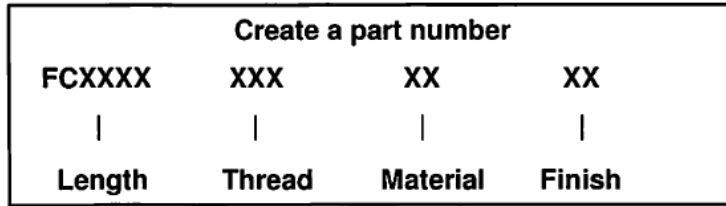

Thread (A)
Short lengths, 'A' tapped to maximum depth

Code (XXX)	Thread	(A)
832	8-32	7/16
1032	10-32	7/16 - 5/8
2520	1/4-20	3/8 - 5/8

Material	
Material Code (XX)	
A	Aluminum
B	Brass
SS	Stainless Steel

See page 3 for finish codes



Fascomp Electronic Hardware
 7814 Kingspointe Pkwy
 Orlando, FL 32819
 www.fascomp.com
 t: (407) 226-2112
 x: (407) 226-3370





Round Off-Set Internal Thread Handles



Fascomp stocks Round Off-Set Internal Thread Handles in aluminum, brass, and stainless steel.

	Page No.
3/16 Handle Size	162
1/4 Handle Size	163
5/16 Handle Size	164
3/8 Handle Size	165



Fascomp Electronic Hardware
7814 Kingspointe Pkwy
Orlando, FL 32819
www.fascomp.com
Tel: (407)
226-2112



Get quote »

Angic Global Solutions 1-888-872-0690
<https://www.AngicGlobal.com> Sales@AngicGlobal.com

3/16 Round Off-Set Internal Thread Handles

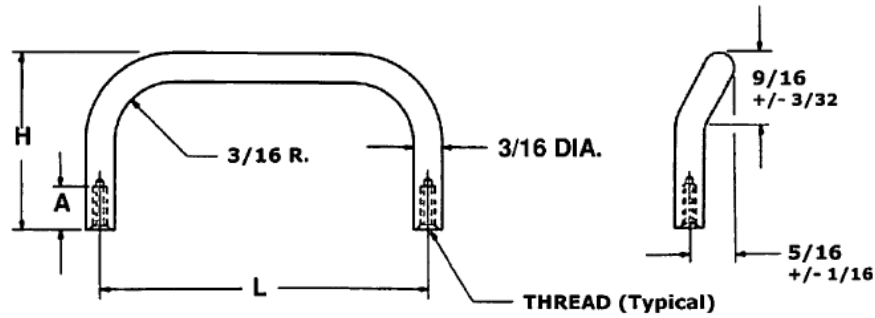

- Contact Sales Office for sizes not shown
- Source Control Drawing: To be produced by Fascomp Electronic Hardware

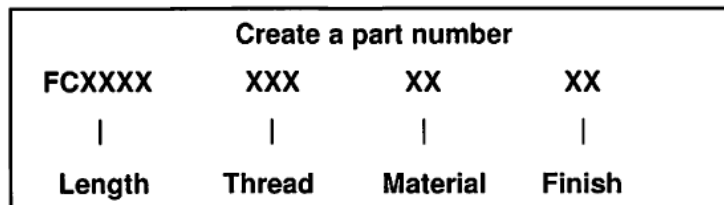

FCXXXX	Length (L) +/- .031	Leg Height (H) +/- .031
FC8248	2	1
FC8249	3	1
FC8250	4	1
FC8251	4-1/2	1
FC8252	5	1
FC8253	6	1
FC8254	2	1-1/2
FC8255	3	1-1/2
FC8256	4	1-1/2
FC8257	4-1/2	1-1/2
FC8258	5	1-1/2
FC8259	6	1-1/2

Thread (A)
Short lengths, 'A' tapped to maximum depth

Code (XXX)	Thread	(A)
440	4-40	1/4 - 5/16
632	6-32	1/4 - 3/8

Material	
Material Code (XX)	
A	Aluminum
B	Brass
SS	Stainless Steel

See page 3 for finish codes



Fascomp Electronic Hardware
7814 Kingspointe Pkwy
Orlando, FL 32819
www.fascomp.com
(407) 226-2112
(407) 226-3370

1/4 Round Off-Set Internal Thread Handles

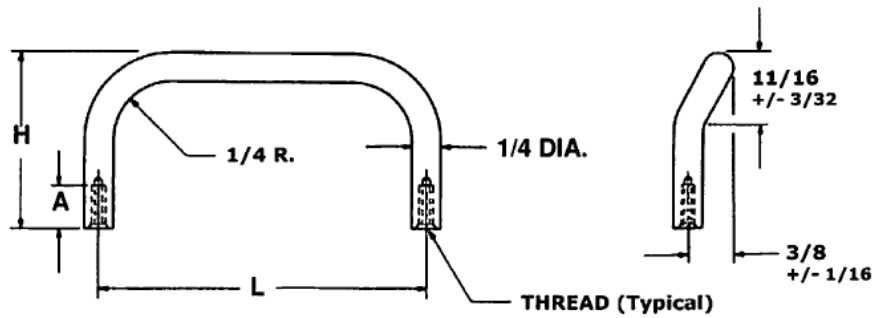

- Contact Sales Office for sizes not shown
- Source Control Drawing: To be produced by Fascomp Electronic Hardware

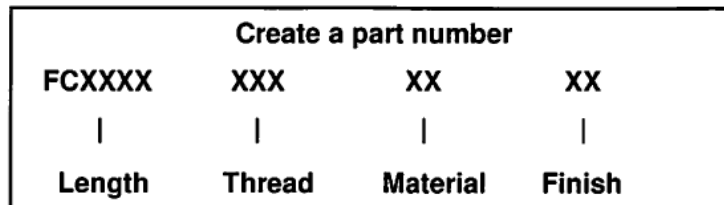

FCXXXX	Length (L) +/- .031	Leg Height (H) +/- .031
FC8260	2	1
FC8261	3	1
FC8262	4	1
FC8263	4-1/2	1
FC8264	5	1
FC8265	6	1
FC8266	2	1-1/2
FC8267	3	1-1/2
FC8268	4	1-1/2
FC8269	4-1/2	1-1/2
FC8270	5	1-1/2
FC8271	5-1/2	1-1/2
FC8272	6	1-1/2
FC8373	2	2
FC8274	3	2
FC8275	4	2
FC8276	4-1/2	2
FC8277	5	2
FC8278	6	2

Thread (A)
Short lengths, 'A' tapped to maximum depth

Code (XXX)	Thread	(A)
632	6-32	5/16 - 7/16
832	8-32	5/16 - 7/16

Material	
Material Code (XX)	
A	Aluminum
B	Brass
SS	Stainless Steel

See page 3 for finish codes



Fascomp Electronic Hardware
7814 Kingspointe Pkwy
Orlando, FL 32819
www.fascomp.com
(407) 226-2112
(407) 226-3370



Get quote >>

Angic Global Solutions 1-888-872-0690
<https://www.AngicGlobal.com> Sales@AngicGlobal.com

5/16 Round Off-Set Internal Thread Handles

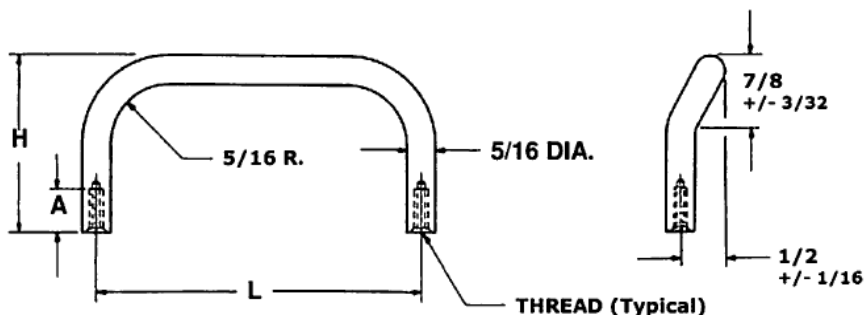

- Contact Sales Office for sizes not shown
- Source Control Drawing: To be produced by Fascomp Electronic Hardware

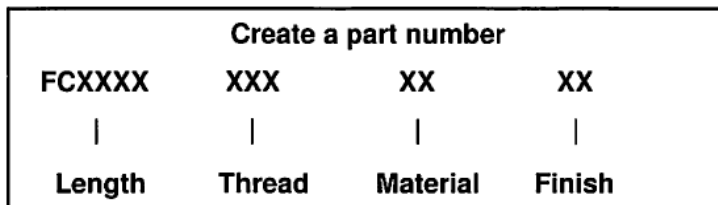

FCXXX	Length (L) +/- .031	Leg Height (H) +/- .031
FC8279	2	1-5/16
FC8280	2-1/2	1-5/16
FC8281	3	1-5/16
FC8282	4	1-5/16
FC8283	5	1-5/16
FC8284	6	1-5/16
FC8285	3	1-1/2
FC8286	4	1-1/2
FC8287	4-1/4	1-1/2
FC8288	4-1/2	1-1/2
FC8289	4-9/16	1-1/2
FC8290	5	1-1/2
FC8291	5-1/2	1-1/2
FC8392	6	1-1/2
FC8293	3	1-3/4
FC8294	4	1-3/4
FC8295	4-1/4	1-3/4
FC8296	4-1/2	1-3/4
FC8297	4-9/16	1-3/4
FC9298	5	1-3/4
FC8299	5-1/2	1-3/4
FC8300	6	1-3/4

Thread (A)
Short lengths, 'A' tapped to maximum depth

Code (XXX)	Thread	(A)
832	8-32	5/16 - 7/16
1032	10-32	5/16 - 1/2

Material	
Material Code (XX)	
A	Aluminum
B	Brass
SS	Stainless Steel

See page 3 for finish codes



Fascomp Electronic Hardware
 7814 Kingspointe Pkwy
 Orlando, FL 32819
 www.fascomp.com
 Tel: (407) 226-2112
 Fax: (407) 226-3370



3/8 Round Off-Set Internal Thread Handles

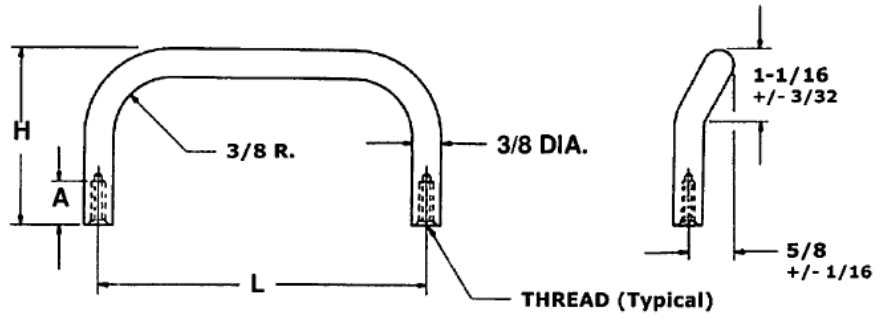

- Contact Sales Office for sizes not shown
- Source Control Drawing: To be produced by Fascomp Electronic Hardware

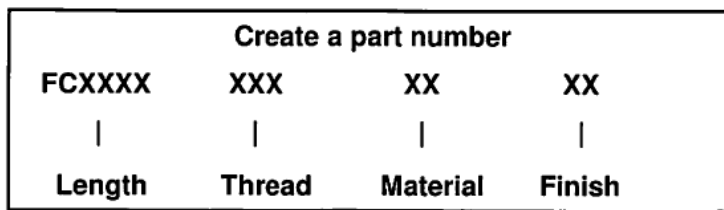

FCXXXX	Length (L) +/- .031	Leg Height (H) +/- .031
FC8301	3	1-3/4
FC8302	4	1-3/4
FC8303	4-1/4	1-3/4
FC8304	4-1/2	1-3/4
FC8305	4-9/16	1-3/4
FC8306	5	1-3/4
FC8307	5-1/2	1-3/4
FC8308	6	1-3/4
FC8309	3	2
FC8310	4	2
FC8311	4-1/4	2
FC8312	4-1/2	2
FC8313	4-9/16	2
FC8314	5	2
FC8315	5-1/2	2
FC8316	6	2

Thread (A)		
Short lengths, 'A' tapped to maximum depth		
Code (XXX)	Thread	(A)
832	8-32	5/16 - 7/16
1032	10-32	1/2 - 9/16

Material	
Material Code (XX)	
A	Aluminum
B	Brass
SS	Stainless Steel

See page 3 for finish codes



Fascomp Electronic Hardware
7814 Kingspointe Pkwy
Orlando, FL 32819
www.fascomp.com
(07) 226-2112
(07) 226-3370



Get quote »

Angic Global Solutions

1-888-872-0690

<https://www.AngicGlobal.com> Sales@AngicGlobal.com



Oval Internal Thread Handles



Fascomp stocks Oval Internal Thread Handles in aluminum, brass, and stainless steel.

Page No.

7/16 x 9/32 Handle Size 167

5/8 x 9/32 Handle Size 168



Fascomp Electronic Hardware
7814 Kingspointe Pkwy
Orlando, FL 32819
www.fascomp.com
Tel: (407)
226-2112



7/16 x 9/32 Oval Internal Thread Handles

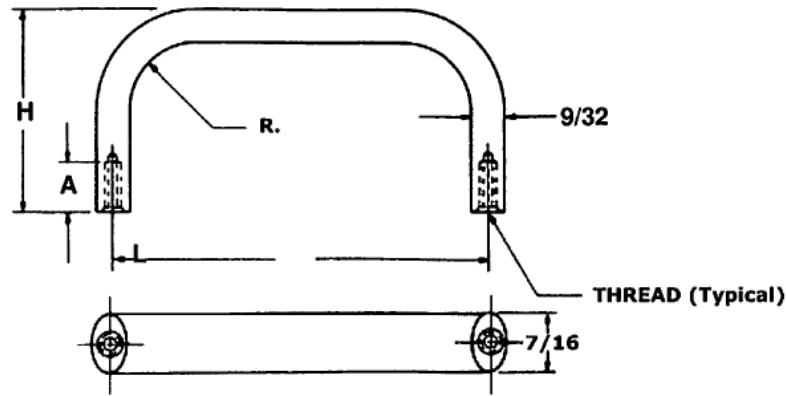

- Contact Sales Office for sizes not shown
- Source Control Drawing: To be produced by Fascomp Electronic Hardware

FCXXXX	Length (L) +/- .031	Leg Height (H) +/- .031
FC8317	2	1
FC8318	2-1/2	1
FC8319	3	1
FC8320	4	1
FC8321	4-1/4	1
FC8322	4-1/2	1
FC8323	4-9/16	1
FC8324	5	1
FC8325	6	1
FC8326	6-7/16	1
FC8327	2	1-9/32
FC8328	2-1/4	1-9/32
FC8329	2-1/2	1-9/32
FC8330	3	1-9/32
FC8331	3/12	1-9/32
FC8332	4	1-9/32
FC8333	4-1/4	1-9/32
FC8334	4-1/2	1-9/32
FC8335	4-9/16	1-9/32
FC8336	6	1-9/32
FC8337	2	1-1/2
FC8338	2-1/4	1-1/2
FC8339	2-1/2	1-1/2
FC8340	3	1-1/2
FC8341	3-1/2	1-1/2
FC8342	4	1-1/2
FC8343	4-1/4	1-1/2
FC8344	4-1/2	1-1/2
FC8345	4-9/16	1-1/2
FC8346	5	1-1/2
FC8347		

Create a part number			
FCXXXX	XXX	XX	XX
Length	Thread	Material	Finish

Thread (A) Short lengths, 'A' tapped to maximum depth		
Code (XXX)	Thread	(A)
832	8-32	5/16 - 1/2
1024	10-24	5/16 - 5/8
1032	10-32	5/16 - 5/8

Material	
Material Code (XX)	
A	Aluminum
B	Brass
SS	Stainless Steel

See page 3 for finish codes



Fascomp Electronic Hardware
7814 Kingspointe Pkwy
Orlando, FL 32819
www.fascomp.com
(407) 226-2112
(407) 226-3370



Get quote »

Angic Global Solutions

1-888-872-0690

<https://www.AngicGlobal.com> Sales@AngicGlobal.com

5/8 x 9/32 Oval Internal Thread Handles

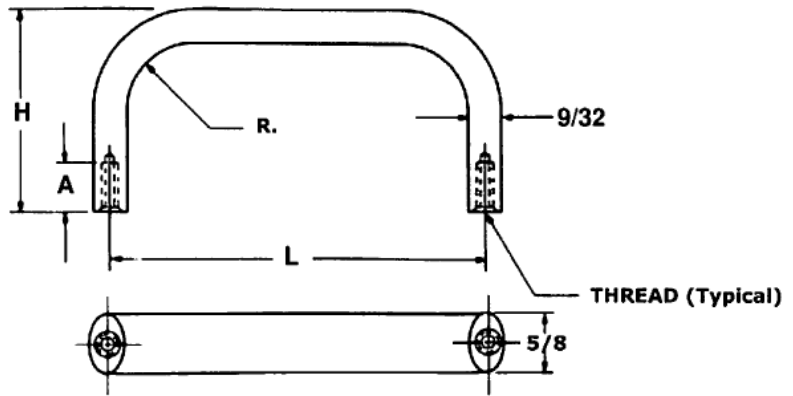

FCXXXX	Length (L) +/- .031	Leg Height (H) +/- .031
FC8348	2-1/2	1
FC8349	3	1
FC8350	4	1
FC8351	4-1/4	1
FC8352	4-1/2	1
FC8353	4-9/16	1
FC8354	5	1
FC8355	6	1
FC8356	6-7/16	1
FC8357	2-1/2	1-9/32
FC8358	3	1-9/32
FC8359	4	1-9/32
FC8360	4-1/4	1-9/32
FC8361	4-1/2	1-9/32
FC8362	4-9/16	1-9/32
FC8363	5	1-9/32
FC8364	6	1-9/32
FC8365	6-7/16	1-9/32
FC8366	2-1/2	1-1/2
FC8367	3	1-1/2
FC8368	4	1-1/2
FC8369	4-1/4	1-1/2
FC8370	4-1/2	1-1/2
FC8371	4-9/16	1-1/2
FC8372	5	1-1/2
FC8373	6	1-1/2
FC8374	6-7/16	1-1/2
FC8375	7	1-1/2
FC8376	3	1-3/4
FC8377	4	1-3/4
FC8378	4-1/4	1-3/4
FC8379	4-1/2	1-3.4
FC8380	4-9/16	1-3.4
FC8381	5	1-3.4
FC8382	5-1/2	1-3/4
FC8383	6	1-3/4
FC8384	6-7/16	1-3/4
FC8385	7	1-3/4

- Contact Sales Office for sizes not shown
- Source Control Drawing: To be produced by Fascomp Electronic Hardware

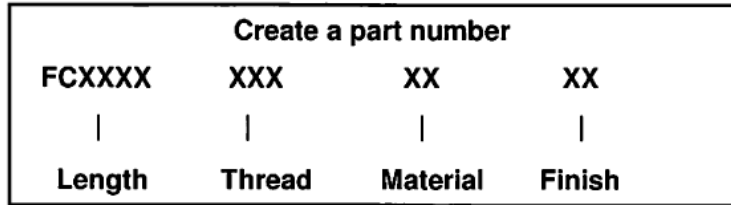

Thread (A)
Short lengths, 'A' tapped to maximum depth

Code (XXX)	Thread	(A)
832	8-32	5/16 - 5/8
1024	10-24	5/16 - 5/8
1032	10-32	5/16 - 5/8

Material	
Material Code (XX)	
A	Aluminum
B	Brass
SS	Stainless Steel

See page 3 for finish codes



Fascomp Electronic Hardware
7814 Kingspointe Pkwy
Orlando, FL 32819
www.fascomp.com
Tel: (407) 226-7111
Fax: (407) 226-7112





Ferrules



Fascomp stocks type 1, type 2, type 3, type 4, type 5, and type 6 Ferrules in brass, steel, and stainless steel.

	Page No.
Type 1	170
Type 2	171
Type 3	172
Type 4	173
Type 5	174
Type 6	175



Fascomp Electronic Hardware
7814 Kingspointe Pkwy
Orlando, FL 32819
www.fascomp.com
Tel: (407)
226-2112



Get quote »

Angic Global Solutions 1-888-872-0690
<https://www.AngicGlobal.com> Sales@AngicGlobal.com

Ferrules Type 1

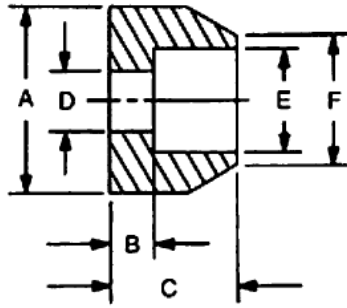

- Contact Sales Office for sizes not shown
- Source Control Drawing: To be produced by Fascomp Electronic Hardware

Create a part number		
FCXXXX	XX	XX
Length	Material	Finish

FCXXXX	A + .005 - .005	B + .005 - .005	C + .005 - .005	D + .005 - .005	E + .005 - .005	F + .015 - .015
FC8972	1/4	.046	.125	.116	.136	13/64
FC8973	1/4	.046	.125	.116	.161	13/64
FC8974	5/16	.062	.125	.141	.203	17/64
FC8975	3/8	.062	.125	.141	.260	5/16
FC8976	3/8	.062	.187	.204	.260	5/16
FC8977	7/16	.062	.187	.204	.260	5/16
FC8978	1/2	.062	.250	.187	.260	11/32
FC8979	15/32	.062	.250	.221	.320	13/32
FC8980	9/16	.062	.250	.221	.320	13/32
FC8981	5/8	.093	.375	.250	.385	15/32
FC8982	3/4	.093	.375	.315	.515	39/64

Material	
Material Code (XX)	
A	Aluminum
B	Brass
S	Steel
SS	Stainless Steel

See page 3 for finish codes



Fascomp Electronic Hardware
7814 Kingspointe Pkwy
Orlando, FL 32819
www.fascomp.com
Tel: (407) 226-2112
(407) 226-3370



Ferrules Type 2

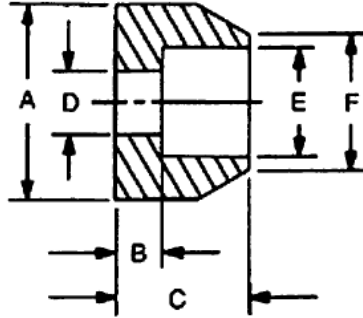

- Contact Sales Office for sizes not shown
- Source Control Drawing: To be produced by Fascomp Electronic Hardware

Create a part number		
FCXXXX	XX	XX
Length	Material	Finish

FCXXXX	A + .005 - .005	B + .005 - .005	C + .005 - .005	D + .005 - .005	E + .005 - .005	F + .015 - .015
FC8983	1/4	.047	.125	.109	.161	13/64
FC8984	5/16	.062	.125	.141	.203	17/64
FC8985	3/8	.062	.187	.203	.260	5/16
FC8986	9/16	.062	.250	.219	.320	13/32
FC8987	3/4	.094	.312	.196	.320	13/32
FC8988	7/8	.094	.312	.196	.385	9/16
FC8989	7/8	.094	.312	.219	.385	9/16
FC8990	7/8	.187	.562	.275	.510	5/8

Material	
Material Code (XX)	
A	Aluminum
B	Brass
S	Steel
SS	Stainless Steel

See page 3 for finish codes



Fascomp Electronic Hardware
 7814 Kingspointe Pkwy
 Orlando, FL 32819
 www.fascomp.com
 Tel: (407) 226-2112
 Fax: (407) 226-3370



Get quote »

Angic Global Solutions 1-888-872-0690
<https://www.AngicGlobal.com> Sales@AngicGlobal.com

Ferrules Type 3

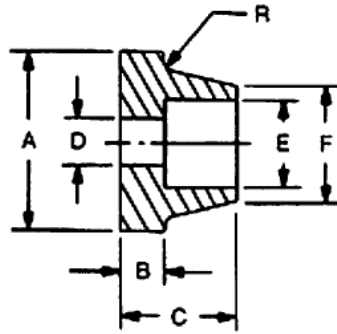

- Contact Sales Office for sizes not shown
- Source Control Drawing: To be produced by Fascomp Electronic Hardware

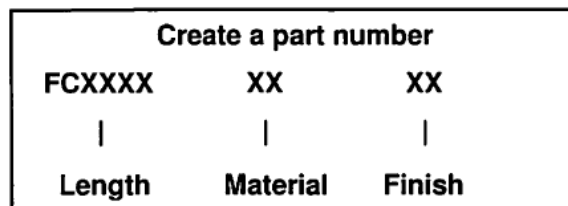

FCXXXX	A	B	C	D	E	F
	+ .005 - .005	+ .005 - .005	+ .005 - .005	+ .005 - .005	+ .005 - .005	+ .015 - .015
FC8991	5/8	.062	.375	.201	.257	21/64
FC8992	3/4	.062	.375	.201	.322	25/64
FC8993	3/4	.062	.375	.201	.383	29/64

Material	
Material Code (XX)	
A	Aluminum
B	Brass
S	Steel
SS	Stainless Steel

See page 3 for finish codes



Fascomp Electronic Hardware
 7814 Kingspointe Pkwy
 Orlando, FL 32819
 www.fascomp.com
 (407) 226-2112
 (407) 226-3370

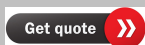

Ferrules Type 4

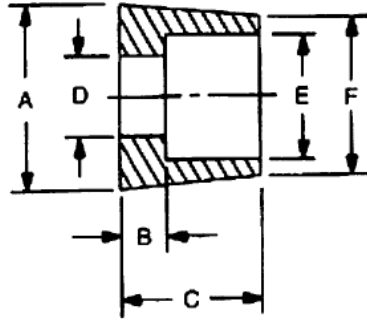

- Contact Sales Office for sizes not shown
- Source Control Drawing: To be produced by Fascomp Electronic Hardware

Create a part number		
FCXXXX	XX	XX
Length	Material	Finish

FCXXXX	A +.005 -.005	B +.005 -.005	C +.005 -.005	D +.005 -.005	E +.005 -.005	F +.015 -.015
FC8994	9/16	.093	.312	.203	.323	7/16
FC8995	5/8	.125	.437	.281	.390	7/16
FC8996	3/4	.187	.562	.328	.510	19/32

Material	
Material Code (XX)	
A	Aluminum
B	Brass
S	Steel
SS	Stainless Steel

See page 3 for finish codes



Fascomp Electronic Hardware
 7814 Kingspointe Pkwy
 Orlando, FL 32819
 www.fascomp.com
 (407) 226-2112
 (407) 226-3370



Get quote »

Angic Global Solutions 1-888-872-0690
<https://www.AngicGlobal.com> Sales@AngicGlobal.com

Ferrules Type 5

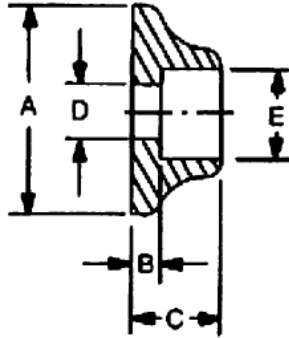

- Contact Sales Office for sizes not shown
- Source Control Drawing: To be produced by Fascomp Electronic Hardware

Create a part number		
FCXXX	XX	XX
Length	Material	Finish

FCXXX	A	B	C	D	E
	+ .005 - .005	+ .005 - .005	+ .005 - .005	+ .005 - .005	+ .005 - .005
FC8997	3/4	.093	.312	.196	.320

Material	
Material Code (XX)	
A	Aluminum
B	Brass
S	Steel
SS	Stainless Steel

See page 3 for finish codes



Fascomp Electronic Hardware
 7814 Kingspointe Pkwy
 Orlando, FL 32819
 www.fascomp.com
 Tel: (407) 226-2112
 Fax: (407) 226-3370



Ferrules Type 6

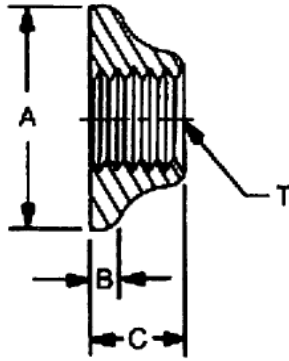

- Contact Sales Office for sizes not shown
- Source Control Drawing: To be produced by Fascomp Electronic Hardware

Create a part number		
FCXXX	XX	XX
Length	Material	Finish

FCXXX	A +.005 -.005	B +.005 -.005	C +.005 -.005	T Thread
FC8998	5/8	1/32	.250	5/16-18
FC8999	3/4	1/16	.312	3/8-24

Material	
Material Code (XX)	
A	Aluminum
B	Brass
S	Steel
SS	Stainless Steel

See page 3 for finish codes



Fascomp Electronic Hardware
 7814 Kingspointe Pkwy
 Orlando, FL 32819
 www.fascomp.com
 : (407) 226-2112
 : (407) 226-3370



Get quote »

Angic Global Solutions

1-888-872-0690

<https://www.AngicGlobal.com> Sales@AngicGlobal.com



Metric Spacers



Fascomp stocks round Metric Spacers in aluminum, brass, steel, stainless steel.

	Page No.
4.5mm	177
6mm	178
8mm	179
10mm	180
13mm	181
16mm	182
19mm	183



Fascomp Electronic Hardware
7814 Kingspointe Pkwy
Orlando, FL 32819
www.fascomp.com
Tel: (407)
226-2112



Metric Spacers 4.5 mm

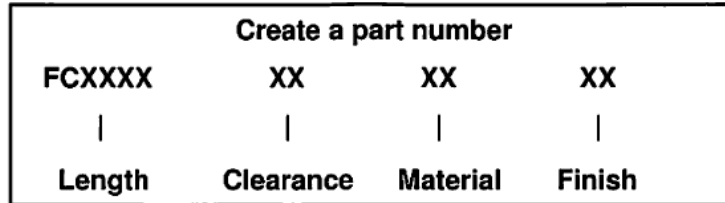
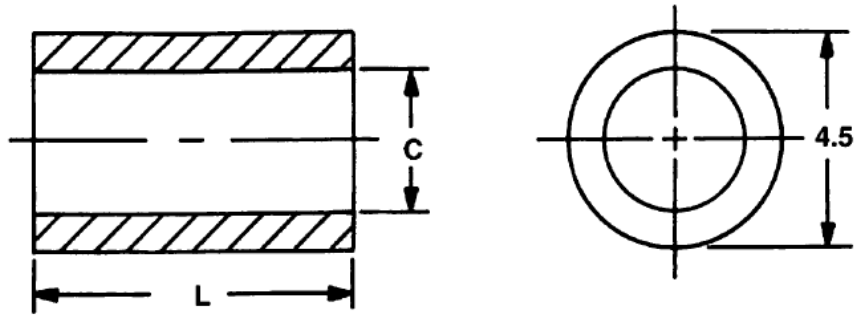

- Contact Sales Office for sizes not shown
- Source Control Drawing: To be produced by Fascomp Electronic Hardware

FMXXX	Length (L)
FM0500	1
FM0501	2
FM0502	3
FM0503	4
FM0504	5
FM0505	6
FM0506	7
FM0507	8
FM0508	9
FM0509	10
FM0510	11
FM0511	12
FM0512	13
FM0513	14
FM0514	15
FM0515	16
FM0516	17
FM0517	18
FM0518	19
FM0519	20
FM0520	21
FM0521	22
FM0522	23
FM0523	24
FM0524	25

Hole Clearance Code (XX)		
Code (XX)	Thread	C +0.3 -0.0
25	M2.5	2.7
3	M3	3.2

Material	
Material Code (XX)	
A	Aluminum
B	Brass
S	Steel
SS	Stainless Steel
N	Nylon

See page 3 for finish codes



Fascomp Electronic Hardware
 7814 Kingspointe Pkwy
 Orlando, FL 32819
 www.fascomp.com
 (407) 226-2112
 (407) 226-3370



Angic Global Solutions 1-888-872-0690
<https://www.AngicGlobal.com> Sales@AngicGlobal.com

Metric Spacers 6 mm

FMXXXX	Length (L)
FM0530	1
FM0531	2
FM0532	3
FM0533	4
FM0534	5
FM0535	6
FM0536	7
FM0537	8
FM0538	9
FM0539	10
FM0540	11
FM0541	12
FM0542	13
FM0543	14
FM0544	15
FM0545	16
FM0546	17
FM0547	18
FM0548	19
FM0549	20
FM0550	21
FM0551	22
FM0552	23
FM0553	24
FM0554	25
FM0555	26
FM0556	27
FM0557	28
FM0558	29
FM0559	30
FM0560	31
FM0561	32
FM0562	33
FM0563	34
FM0564	35
FM0565	36
FM0566	37
FM0567	38
FM0568	39
FM0569	40
FM0570	41
FM0571	42
FM0572	43
FM0573	44
FM0574	45
FM0575	46
FM0576	47
FM0577	48
FM0578	49
FM0579	50
FM0580	51

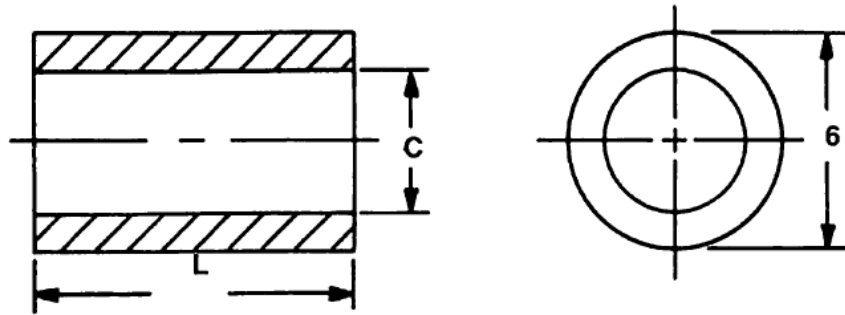

Create a part number			
FCXXXX	XX	XX	XX
Length	Clearance	Material	Finish

- Contact Sales Office for sizes not shown
- Source Control Drawing: To be produced by Fascomp Electronic Hardware

Hole Clearance Code (XX)		
Code (XX)	Thread	C +0.3 -0.0
3	M3	3.2
35	M3.5	3.7
4	M4	4.3

Material	
Material Code (XX)	
A	Aluminum
B	Brass
S	Steel
SS	Stainless Steel
N	Nylon

See page 3 for finish codes



Fascomp Electronic Hardware
7814 Kingspointe Pkwy
Orlando, FL 32819
www.fascomp.com
Tel: (407) 226-2112
(407) 226-3370

Metric Spacers 8 mm

FMXXX	Length (L)
FM0590	1
FM0591	2
FM0592	3
FM0593	4
FM0594	5
FM0595	6
FM0596	7
FM0597	8
FM0598	9
FM0599	10
FM0600	11
FM0601	12
FM0602	13
FM0603	14
FM0604	15
FM0605	16
FM0606	17
FM0607	18
FM0608	19
FM0609	20
FM0610	21
FM0611	22
FM0612	23
FM0613	24
FM0614	25
FM0615	26
FM0616	27
FM0617	28
FM0618	29
FM0619	30
FM0620	31
FM0621	32
FM0622	33
FM0623	34
FM0624	35
FM0625	36
FM0626	37
FM0627	38
FM0628	39
FM0629	40
FM0630	41
FM0631	42
FM0632	43
FM0633	44
FM0634	45
FM0635	46
FM0636	47
FM0637	48
FM0638	49
FM0639	50
FM0640	51

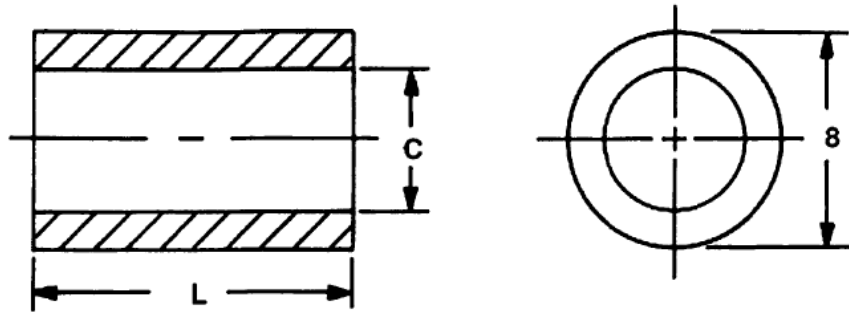

Create a part number			
FCXXX	XX	XX	XX
Length	Clearance	Material	Finish

- Contact Sales Office for sizes not shown
- Source Control Drawing: To be produced by
- Fascomp Electronic Hardware

Hole Clearance Code (XX)		
Code (XX)	Thread	C +0.3 -0.0
3	M3	3.2
35	M3.5	3.7
4	M4	4.3
5	M5	5.3

Material	
Material Code (XX)	
A	Aluminum
B	Brass
S	Steel
SS	Stainless Steel
N	Nylon

See page 3 for finish codes



Fascomp Electronic Hardware
7814 Kingspointe Pkwy
Orlando, FL 32819
www.fascomp.com
Tel: (407) 226-2117
Fax: (407) 226-3377



Get quote »

Angic Global Solutions

1-888-872-0690

<https://www.AngicGlobal.com> Sales@AngicGlobal.com

Metric Spacers 10 mm

FMXXX	Length (L)
FM0650	1
FM0651	2
FM0652	3
FM0653	4
FM0654	5
FM0655	6
FM0656	7
FM0657	8
FM0658	9
FM0659	10
FM0660	11
FM0661	12
FM0662	13
FM0663	14
FM0664	15
FM0665	16
FM0666	17
FM0667	18
FM0668	19
FM0669	20
FM0670	21
FM0671	22
FM0672	23
FM0673	24
FM0674	25
FM0675	26
FM0676	27
FM0677	28
FM0678	29
FM0679	30
FM0680	31
FM0681	32
FM0682	33
FM0683	34
FM0684	35
FM0685	36
FM0686	37
FM0687	38
FM0688	39
FM0689	40
FM0690	41
FM0691	42
FM0692	43
FM0693	44
FM0694	45
FM0695	46
FM0696	47
FM0697	48
FM0698	49
FM0699	50
FM0700	51

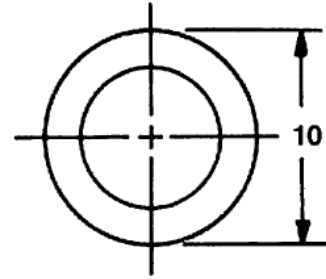
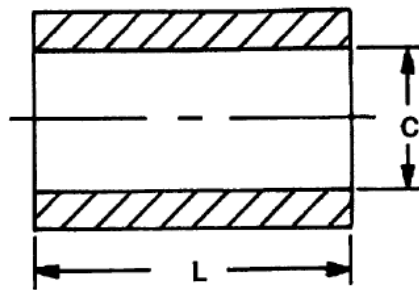

Create a part number			
FCXXX	XX	XX	XX
Length	Clearance	Material	Finish

- Contact Sales Office for sizes not shown
- Source Control Drawing: To be produced by
- Fascomp Electronic Hardware

Hole Clearance Code (XX)		
Code (XX)	Thread	C +0.3 -0.0
35	M3.5	3.7
4	M4	4.3
5	M5	5.3

Material	
Material Code (XX)	
A	Aluminum
B	Brass
S	Steel
SS	Stainless Steel
N	Nylon

See page 3 for finish codes



Fascomp Electronic Hardware
 7814 Kingspointe Pkwy
 Orlando, FL 32819
 www.fascomp.com
 Tel: (407) 226-2112
 Fax: (407) 226-3370

Metric Spacers 13 mm

FMXXX	Length (L)
FM0710	1
FM0711	2
FM0712	3
FM0713	4
FM0714	5
FM0715	6
FM0716	7
FM0717	8
FM0718	9
FM0719	10
FM0720	11
FM0721	12
FM0722	13
FM0723	14
FM0724	15
FM0725	16
FM0726	17
FM0727	18
FM0728	19
FM0729	20
FM0730	21
FM0731	22
FM0732	23
FM0733	24
FM0734	25
FM0735	26
FM0736	27
FM0737	28
FM0738	29
FM0739	30
FM0740	31
FM0741	32
FM0742	33
FM0743	34
FM0744	35
FM0745	36
FM0746	37
FM0747	38
FM0748	39
FM0749	40
FM0750	41
FM0751	42
FM0752	43
FM0753	44
FM0754	45
FM0755	46
FM0756	47
FM0757	48
FM0758	49
FM0759	50
FM0760	

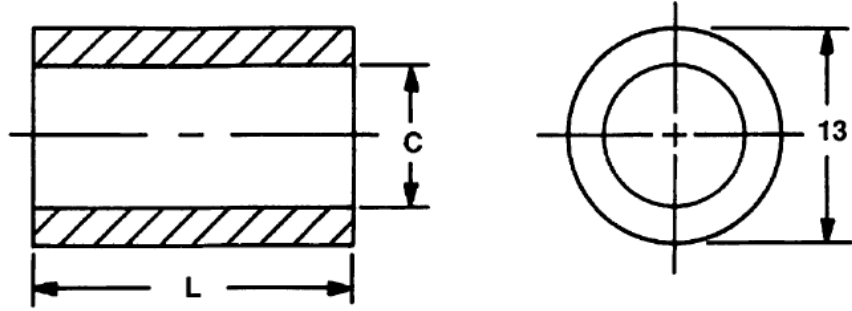

Create a part number			
FCXXX	XX	XX	XX
Length	Clearance	Material	Finish

- Contact Sales Office for sizes not shown
- Source Control Drawing: To be produced by
- Fascomp Electronic Hardware

Hole Clearance Code (XX)		
Code (XX)	Thread	C +0.3 -0.0
4	M4	4.3
5	M5	5.3
6	M6	6.4
8	M8	8.4

Material	
Material Code (XX)	
A	Aluminum
B	Brass
S	Steel
SS	Stainless Steel
N	Nylon

See page 3 for finish codes



Fascomp Electronic Hardware
7814 Kingspointe Pkwy
Orlando, FL 32819
www.fascomp.com
(407) 226-2112
(407) 226-3370



Get quote »

Angic Global Solutions

1-888-872-0690

<https://www.AngicGlobal.com> Sales@AngicGlobal.com

Metric Spacers 16 mm

FMXXX	Length (L)
FM0770	1
FM0771	2
FM0772	3
FM0773	4
FM0774	5
FM0775	6
FM0776	7
FM0777	8
FM0778	9
FM0779	10
FM0780	11
FM0781	12
FM0782	13
FM0783	14
FM0784	15
FM0785	16
FM0786	17
FM0787	18
FM0788	19
FM0789	20
FM0790	21
FM0791	22
FM0792	23
FM0793	24
FM0794	25
FM0795	26
FM0796	27
FM0797	28
FM0798	29
FM0799	30
FM0800	31
FM0801	32
FM0802	33
FM0803	34
FM0804	35
FM0805	36
FM0806	37
FM0807	38
FM0808	39
FM0809	40
FM0810	41
FM0811	42
FM0812	43
FM0813	44
FM0814	45
FM0815	46
FM0816	47
FM0817	48
FM0818	49
FM0819	50
FM0820	51

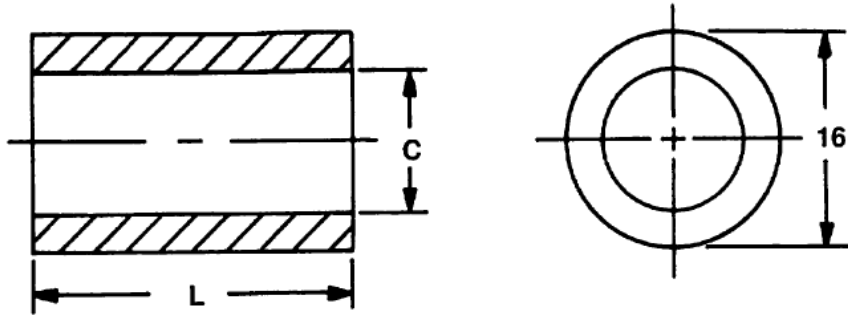

Create a part number			
FCXXX	XX	XX	XX
Length	Clearance	Material	Finish

- Contact Sales Office for sizes not shown
- Source Control Drawing: To be produced by
- Fascomp Electronic Hardware

Hole Clearance Code (XX)		
Code (XX)	Thread	C +0.3 - 0.0
4	M4	4.3
5	M5	5.3
6	M6	6.4
8	M8	8.4
10	M10	10.5
12	M12	13

Material	
Material Code (XX)	
A	Aluminum
B	Brass
S	Steel
SS	Stainless Steel
N	Nylon

See page 3 for finish codes



Fascomp Electronic Hardware
7814 Kingspointe Pkwy
Orlando, FL 32819
www.fascomp.com
(407) 226-2112
(407) 226-3370

Metric Spacers 19 mm

FMXXXX	Length (L)
FM0830	1
FM0831	2
FM0832	3
FM0833	4
FM0834	5
FM0835	6
FM0836	7
FM0837	8
FM0838	9
FM0839	10
FM0840	11
FM0841	12
FM0842	13
FM0843	14
FM0844	15
FM0845	16
FM0846	17
FM0847	18
FM0848	19
FM0849	20
FM0850	21
FM0851	22
FM0852	23
FM0853	24
FM0854	25
FM0855	26
FM0856	27
FM0857	28
FM0858	29
FM0859	30
FM0860	31
FM0861	32
FM0862	33
FM0863	34
FM0864	35
FM0865	36
FM0866	37
FM0867	38
FM0868	39
FM0869	40
FM0870	41
FM0871	42
FM0872	43
FM0873	44
FM0874	45
FM0875	46
FM0876	47
FM0877	48
FM0878	49
FM0879	50
FM0880	

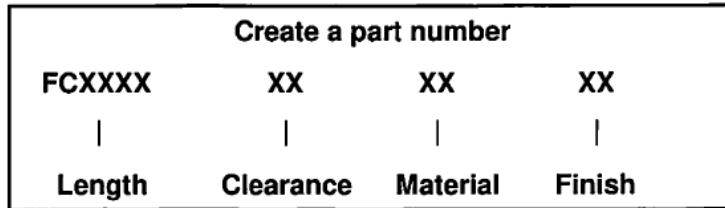
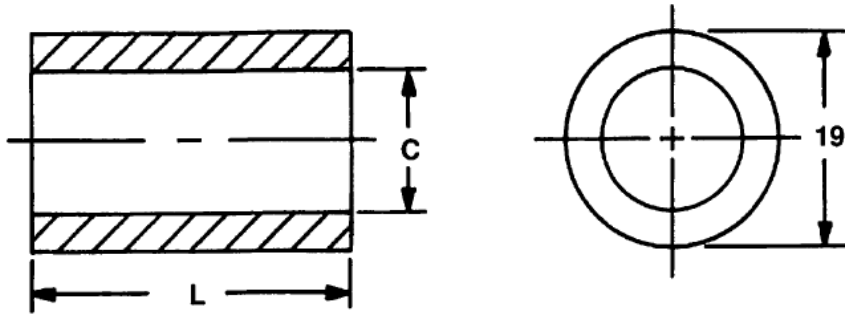

- Contact Sales Office for sizes not shown
- Source Control Drawing: To be produced by
- Fascomp Electronic Hardware

Hole Clearance Code (XX)		
Code (XX)	Thread	C +0.3 -0.0
4	M4	4.3
5	M5	5.3
6	M6	6.4
8	M8	8.4
10	M10	10.5
12	M12	13
14	M14	15

Material	
Material Code (XX)	
A	Aluminum
B	Brass
S	Steel
SS	Stainless Steel
N	Nylon

See page 3 for finish codes



Fascomp Electronic Hardware
 7814 Kingspointe Pkwy
 Orlando, FL 32819
 www.fascomp.com
 Tel: (407) 226-2111
 Fax: (407) 226-3377



Get quote »

Angic Global Solutions

1-888-872-0690

<https://www.AngicGlobal.com> Sales@AngicGlobal.com



Metric Female Standoffs



Fascomp Stocks both hex and round Metric Female Standoffs in aluminum, brass, steel, stainless steel.

	Page No.
4.5mm Round	185
6mm Round	186
8mm Round	187
10mm Round	188
13mm Round	189
4.5mm Hex	190
6mm Hex	191
8mm Hex	192
10mm Hex	193
13mm Hex	194



Fascomp Electronic Hardware
7814 Kingspointe Pkwy
Orlando, FL 32819
www.fascomp.com
Tel: (407)
226-2112



Metric 4.5mm Round Female Standoff

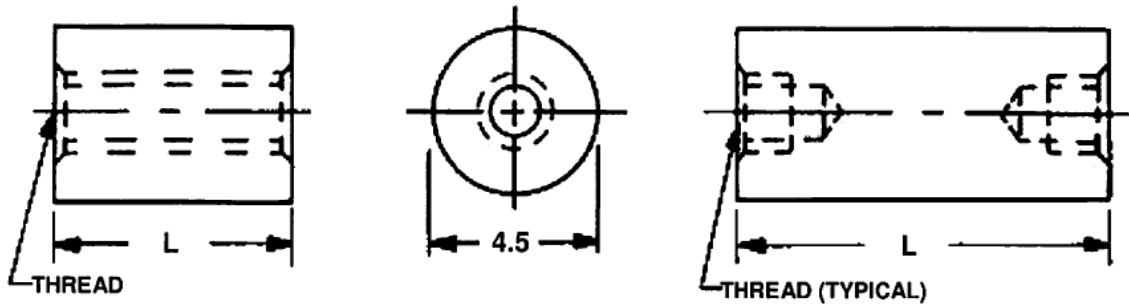

- Contact Sales Office for sizes not shown
- Source Control Drawing: To be produced by Fascomp Electronic Hardware

FMXXXX	Length (L)
FM1000	3
FM1001	4
FM1002	5
FM1003	6
FM1004	7
FM1005	8
FM1006	9
FM1007	10
FM1008	11
FM1009	12
FM1010	13
FM1011	14
FM1012	15
FM1013	16
FM1014	17
FM1015	18
FM1016	19
FM1017	20
FM1018	21
FM1019	22
FM1020	23
FM1021	24
FM1022	25
FM1023	28
FM1024	31
FM1025	34
FM1026	37
FM1027	40
FM1028	43
FM1029	46
FM1030	49
FM1031	52

Create a part number			
FCXXXX	XXXX	XX	XX
Length	Thread	Material	Finish

Thread			
Thread Code (XXX)	Tapped Thru		Longer Parts
	A, B, S	SS	Blind Tap Depth
2545	19	16	4.7
3005	25	19	6.3

Aluminum (A), Brass (B), Steel (S), Stainless Steel (SS)

Material	
Material Code (XX)	
A	Aluminum
B	Brass
S	Steel
SS	Stainless Steel
N	Nylon

See page 3 for finish codes



Fascomp Electronic Hardware
 7814 Kingspointe Pkwy
 Orlando, FL 32819
 www.fascomp.com
 07) 226-2112
 07) 226-3370



Angic Global Solutions

1-888-872-0690

<https://www.AngicGlobal.com> Sales@AngicGlobal.com

Metric 6mm Round Female Standoff

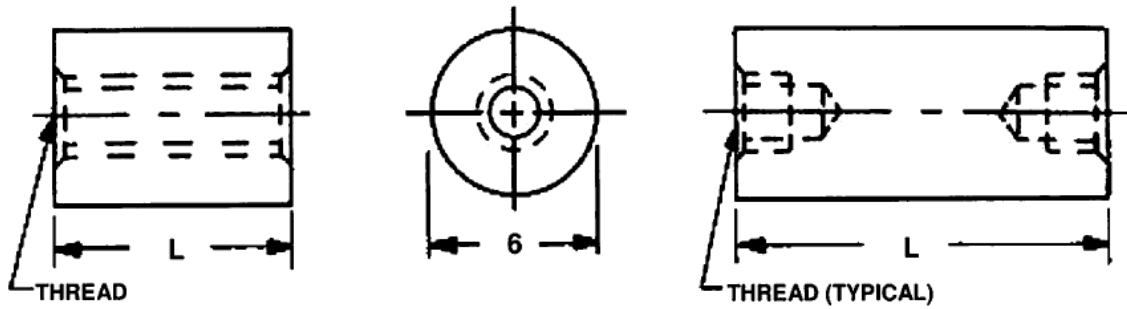

- Contact Sales Office for sizes not shown
- Source Control Drawing: To be produced by Fascomp Electronic Hardware

FMXXX	Length (L)
FM1050	3
FM1051	4
FM1052	5
FM1053	6
FM1054	7
FM1055	8
FM1056	9
FM1057	10
FM1058	11
FM1059	12
FM1060	13
FM1061	14
FM1062	15
FM1063	16
FM1064	17
FM1065	18
FM1066	19
FM1067	20
FM1068	21
FM1069	22
FM1070	23
FM1071	24
FM1072	25
FM1073	28
FM1074	31
FM1075	34
FM1076	37
FM1077	40
FM1078	43
FM1079	46
FM1080	49
FM1081	52

Create a part number			
FCXXX	XXXX	XX	XX
Length	Thread	Material	Finish

Thread			
Thread Code (XXX)	Tapped Thru		Longer Parts
	A, B, S	SS	Blind Tap Depth
3005	25	19	6.3
3506	25	25	9.5
4007	25	25	11.1

Aluminum (A), Brass (B), Steel (S), Stainless Steel (SS)

Material	
Material Code (XX)	
A	Aluminum
B	Brass
S	Steel
SS	Stainless Steel
N	Nylon

See page 3 for finish codes



Fascomp Electronic Hardware
7814 Kingspointe Pkwy
Orlando, FL 32819
www.fascomp.com
07) 226-2112
07) 226-3370

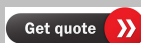

Metric 8mm Round Female Standoff

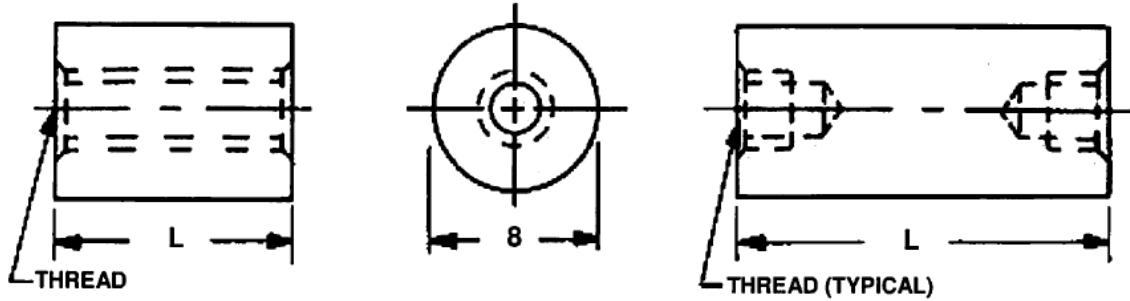

- Contact Sales Office for sizes not shown
- Source Control Drawing: To be produced by Fascomp Electronic Hardware

FMXXXX	Length (L)
FM1100	3
FM1101	4
FM1102	5
FM1103	6
FM1104	7
FM1105	8
FM1106	9
FM1107	10
FM1108	11
FM1109	12
FM1110	13
FM1111	14
FM1112	15
FM1113	16
FM1114	17
FM1115	18
FM1116	19
FM1117	20
FM1118	21
FM1119	22
FM1120	23
FM1121	24
FM1122	25
FM1123	28
FM1124	31
FM1125	34
FM1126	37
FM1127	40
FM1128	43
FM1129	46
FM1130	49
FM1131	52

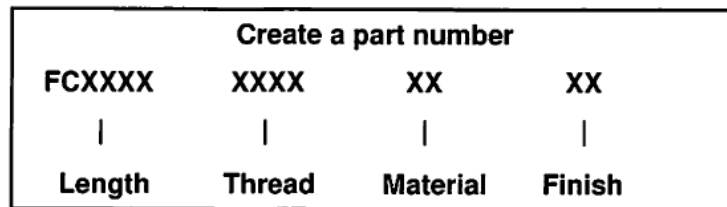

Thread			
Thread Code (XXX)	Tapped Thru		Longer Parts
	A, B, S	SS	Blind Tap Depth
3005	25	19	6.3
3506	25	25	9.5
4007	25	25	11.1
5008	28	25	12.7

Aluminum (A), Brass (B), Steel (S), Stainless Steel (SS)

Material	
Material Code (XX)	
A	Aluminum
B	Brass
S	Steel
SS	Stainless Steel
N	Nylon

See page 3 for finish codes



Fascomp Electronic Hardware
 7814 Kingspointe Pkwy
 Orlando, FL 32819
 www.fascomp.com
 : (407) 226-2112
 : (407) 226-3370

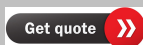

Angic Global Solutions

1-888-872-0690

<https://www.AngicGlobal.com> Sales@AngicGlobal.com

Metric 10mm Round Female Standoff

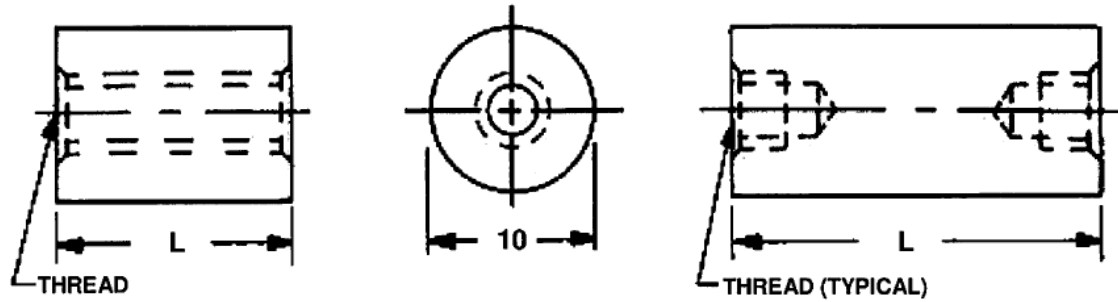

- Contact Sales Office for sizes not shown
- Source Control Drawing: To be produced by Fascomp Electronic Hardware

FMXXX	Length (L)
FM1150	3
FM1151	4
FM1152	5
FM1153	6
FM1154	7
FM1155	8
FM1156	9
FM1157	10
FM1158	11
FM1159	12
FM1160	13
FM1161	14
FM1162	15
FM1163	16
FM1164	17
FM1165	18
FM1166	19
FM1167	20
FM1168	21
FM1169	22
FM1170	23
FM1171	24
FM1172	25
FM1173	28
FM1174	31
FM1175	34
FM1176	37
FM1177	40
FM1178	43
FM1179	46
FM1180	49
FM1181	52

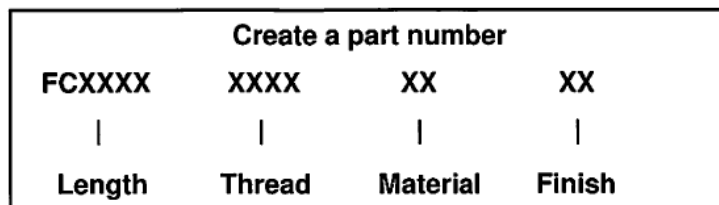

Thread			
Thread Code (XXX)	Tapped Thru		Longer Parts
	A, B, S	SS	Blind Tap Depth
3506	25	25	9.5
4007	25	25	11.1
5008	28	25	12.7

Aluminum (A), Brass (B), Steel (S), Stainless Steel (SS)

Material	
Material Code (XX)	
A	Aluminum
B	Brass
S	Steel
SS	Stainless Steel
N	Nylon

See page 3 for finish codes



Fascomp Electronic Hardware
7814 Kingspointe Pkwy
Orlando, FL 32819
www.fascomp.com
(407) 226-2112
(407) 226-3370



Metric 13mm Round Female Standoff

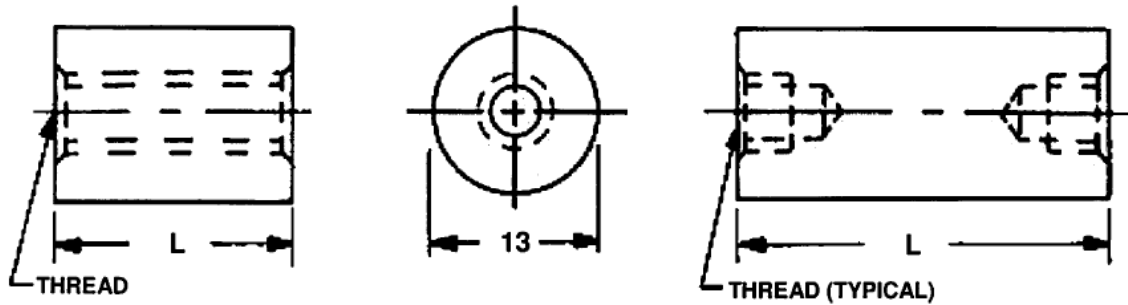

- Contact Sales Office for sizes not shown
- Source Control Drawing: To be produced by Fascomp Electronic Hardware

FMXXXX	Length (L)
FM1200	3
FM1201	4
FM1202	5
FM1203	6
FM1204	7
FM1205	8
FM1206	9
FM1207	10
FM1208	11
FM1209	12
FM1210	13
FM1211	14
FM1212	15
FM1213	16
FM1214	17
FM1215	18
FM1216	19
FM1217	20
FM1218	21
FM1219	22
FM1220	23
FM1221	24
FM1222	25
FM1223	28
FM1224	31
FM1225	34
FM1226	37
FM1227	40
FM1228	43
FM1229	46
FM1230	49
FM1231	52

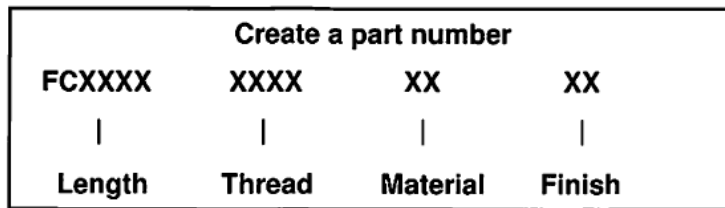

Thread			
Thread Code (XXX)	Tapped Thru		Longer Parts
	A, B, S	SS	Blind Tap Depth
4007	25	25	11.1
5008	28	25	12.7
6010	31	31	16

Aluminum (A), Brass (B), Steel (S), Stainless Steel (SS)

Material	
Material Code (XX)	
A	Aluminum
B	Brass
S	Steel
SS	Stainless Steel
N	Nylon

See page 3 for finish codes



Fascomp Electronic Hardware
 7814 Kingspointe Pkwy
 Orlando, FL 32819
 www.fascomp.com
 Tel: (407) 226-2112
 5-3370



Get quote »

Angic Global Solutions 1-888-872-0690
<https://www.AngicGlobal.com> Sales@AngicGlobal.com

Metric 4.5mm Hex Female Standoff

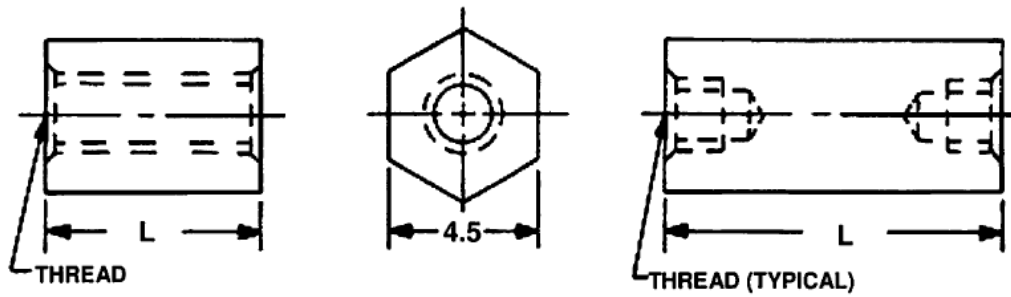

- Contact Sales Office for sizes not shown
- Source Control Drawing: To be produced by Fascomp Electronic Hardware

FMXXXX	Length (L)
FM1250	3
FM1251	4
FM1252	5
FM1253	6
FM1254	7
FM1255	8
FM1256	9
FM1257	10
FM1258	11
FM1259	12
FM1260	13
FM1261	14
FM1262	15
FM1263	16
FM1264	17
FM1265	18
FM1266	19
FM1267	20
FM1268	21
FM1269	22
FM1270	23
FM1271	24
FM1272	25
FM1273	28
FM1274	31
FM1275	34
FM1276	37
FM1277	40
FM1278	43
FM1279	46
FM1280	49
FM1281	52

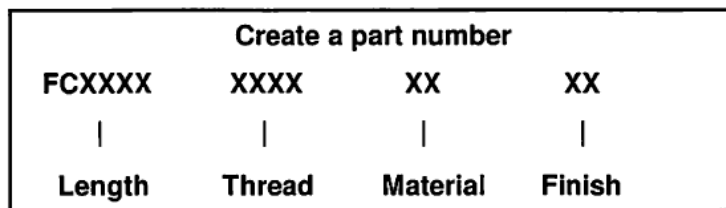

Thread			
Thread Code (XXX)	Tapped Thru		Longer Parts
	A, B, S	SS	Blind Tap Depth
2545	19	16	4.7
3005	25	19	6.3

Aluminum (A), Brass (B), Steel (S), Stainless Steel (SS)

Material	
Material Code (XX)	
A	Aluminum
B	Brass
S	Steel
SS	Stainless Steel
N	Nylon

See page 3 for finish codes



Fascomp Electronic Hardware
7814 Kingspointe Pkwy
Orlando, FL 32819
www.fascomp.com
7) 226-2112
7) 226-3370

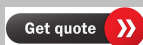

Metric 6mm Hex Female Standoff

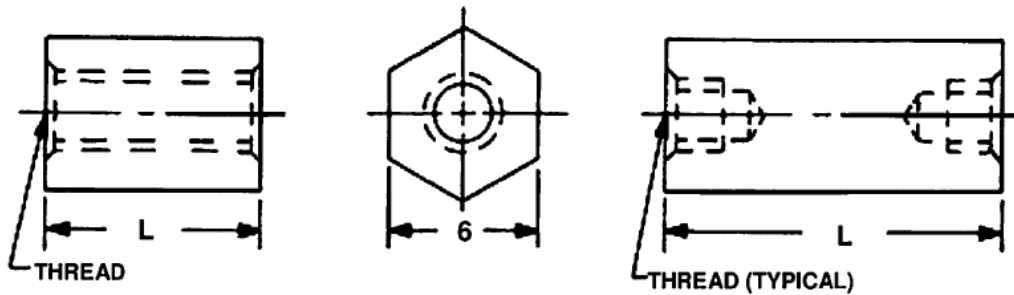

- Contact Sales Office for sizes not shown
- Source Control Drawing: To be produced by Fascomp Electronic Hardware

FMXXXX	Length (L)
FM1300	3
FM1301	4
FM1302	5
FM1303	6
FM1304	7
FM1305	8
FM1306	9
FM1307	10
FM1308	11
FM1309	12
FM1310	13
FM1311	14
FM1312	15
FM1313	16
FM1314	17
FM1315	18
FM1316	19
FM1317	20
FM1318	21
FM1319	22
FM1320	23
FM1321	24
FM1322	25
FM1323	28
FM1324	31
FM1325	34
FM1326	37
FM1327	40
FM1328	43
FM1329	46
FM1330	49
FM1331	52

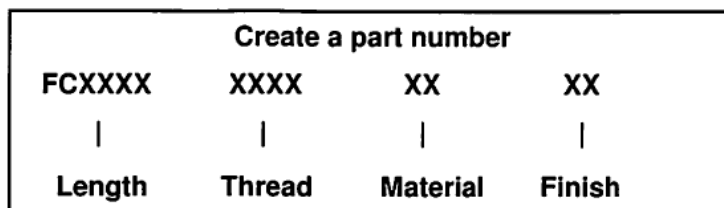

Thread			
Thread Code (XXX)	Tapped Thru		Longer Parts
	A, B, S	SS	Blind Tap Depth
3005	25	19	6.3
3506	25	25	9.5
4007	25	25	11.1

Aluminum (A), Brass (B), Steel (S), Stainless Steel (SS)

Material	
Material Code (XX)	
A	Aluminum
B	Brass
S	Steel
SS	Stainless Steel
N	Nylon

See page 3 for finish codes



Fascomp Electronic Hardware
 7814 Kingspointe Pkwy
 Orlando, FL 32819
 www.fascomp.com
 (407) 226-2112
 (407) 226-3370



Get quote »

Angic Global Solutions

1-888-872-0690

<https://www.AngicGlobal.com> Sales@AngicGlobal.com

Metric 8mm Hex Female Standoff

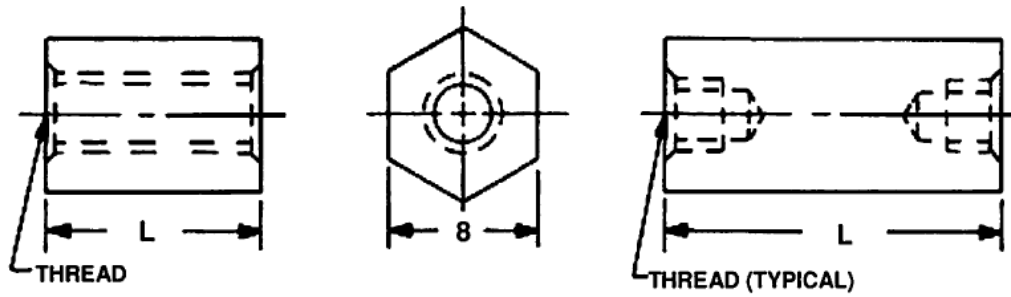

- Contact Sales Office for sizes not shown
- Source Control Drawing: To be produced by Fascomp Electronic Hardware

FMXXXX	Length (L)
FM1350	3
FM1351	4
FM1352	5
FM1353	6
FM1354	7
FM1355	8
FM1356	9
FM1357	10
FM1358	11
FM1359	12
FM1360	13
FM1361	14
FM1362	15
FM1363	16
FM1364	17
FM1365	18
FM1366	19
FM1367	20
FM1368	21
FM1369	22
FM1370	23
FM1371	24
FM1372	25
FM1373	28
FM1374	31
FM1375	34
FM1376	37
FM1377	40
FM1378	43
FM1379	46
FM1380	49
FM1381	52

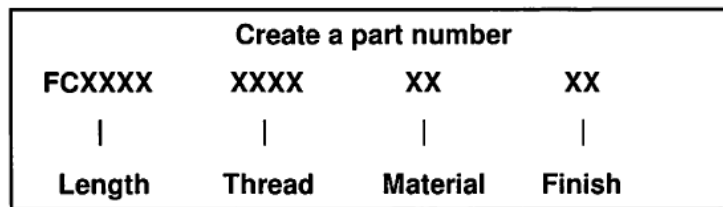

Thread			
Thread Code (XXX)	Tapped Thru		Longer Parts
	A, B, S	SS	Blind Tap Depth
3005	25	19	6.3
3506	25	25	9.5
4007	25	25	11.1
5008	28	25	12.7

Aluminum (A), Brass (B), Steel (S), Stainless Steel (SS)

Material	
Material Code (XX)	
A	Aluminum
B	Brass
S	Steel
SS	Stainless Steel
N	Nylon

See page 3 for finish codes



Fascomp Electronic Hardware
 7814 Kingspointe Pkwy
 Orlando, FL 32819
 www.fascomp.com
 (407) 226-2112
 (407) 226-3370



Metric 10mm Hex Female Standoff

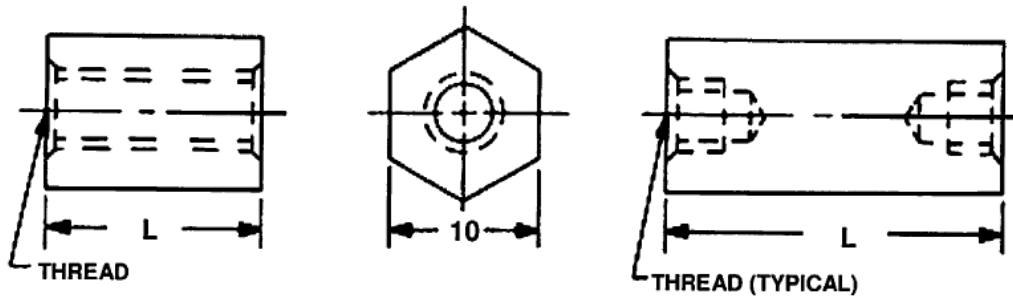

- Contact Sales Office for sizes not shown
- Source Control Drawing: To be produced by Fascomp Electronic Hardware

FMXXXX	Length (L)
FM1400	3
FM1401	4
FM1402	5
FM1403	6
FM1404	7
FM1405	8
FM1406	9
FM1407	10
FM1408	11
FM1409	12
FM1410	13
FM1411	14
FM1412	15
FM1413	16
FM1414	17
FM1415	18
FM1416	19
FM1417	20
FM1418	21
FM1419	22
FM1420	23
FM1421	24
FM1422	25
FM1423	28
FM1424	31
FM1425	34
FM1426	37
FM1427	40
FM1428	43
FM1429	46
FM1430	49
FM1431	52

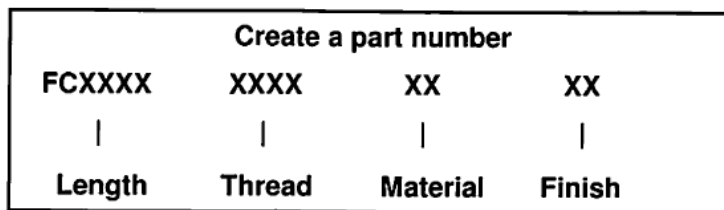

Thread			
Thread Code (XXX)	Tapped Thru		Longer Parts
	A, B, S	SS	Blind Tap Depth
3506	25	25	9.5
4007	25	25	11.1
5008	28	25	12.7

Aluminum (A), Brass (B), Steel (S), Stainless Steel (SS)

Material	
Material Code (XX)	
A	Aluminum
B	Brass
S	Steel
SS	Stainless Steel
N	Nylon

See page 3 for finish codes



Fascomp Electronic Hardware
 7814 Kingspointe Pkwy
 Orlando, FL 32819
 www.fascomp.com
 (407) 226-2112
 (407) 226-3370



Get quote »

Angic Global Solutions 1-888-872-0690
<https://www.AngicGlobal.com> Sales@AngicGlobal.com

Metric 13mm Hex Female Standoff

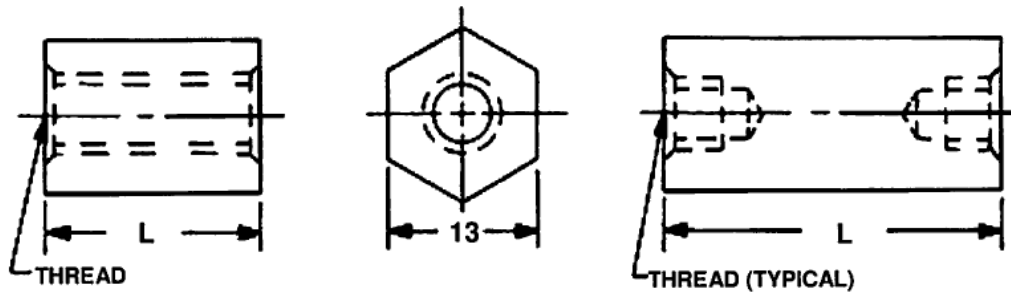

- Contact Sales Office for sizes not shown
- Source Control Drawing: To be produced by Fascomp Electronic Hardware

FMXXXX	Length (L)
FM1450	3
FM1451	4
FM1452	5
FM1453	6
FM1454	7
FM1455	8
FM1456	9
FM1457	10
FM1458	11
FM1459	12
FM1460	13
FM1461	14
FM1462	15
FM1463	16
FM1464	17
FM1465	18
FM1466	19
FM1467	20
FM1468	21
FM1469	22
FM1470	23
FM1471	24
FM1472	25
FM1473	28
FM1474	31
FM1475	34
FM1476	37
FM1477	40
FM1478	43
FM1479	46
FM1480	49
FM1481	52

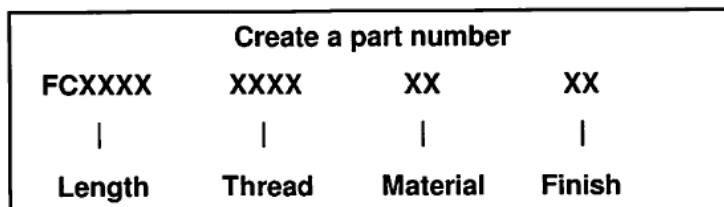

Thread			
Thread Code (XXX)	Tapped Thru		Longer Parts
	A, B, S	SS	Blind Tap Depth
4007	25	25	11.1
5008	28	25	12.7
6010	31	31	16

Aluminum (A), Brass (B), Steel (S), Stainless Steel (SS)

Material	
Material Code (XX)	
A	Aluminum
B	Brass
S	Steel
SS	Stainless Steel
N	Nylon

See page 3 for finish codes



Fascomp Electronic Hardware
 7814 Kingspointe Pkwy
 Orlando, FL 32819
 www.fascomp.com
 : (407) 226-2112
 : (407) 226-3370



Metric Male-Female Standoffs



Fascomp Stocks hex Metric Male-Female Standoffs in aluminum, brass, steel, stainless steel.

Page No.

4.5mm Hex	196
6mm Hex	197
8mm Hex	198
10mm Hex	199
13mm Hex	200



Fascomp Electronic Hardware
7814 Kingspointe Pkwy
Orlando, FL 32819
www.fascomp.com
Tel: (407)
26-2112



Get quote >>

Angic Global Solutions 1-888-872-0690
<https://www.AngicGlobal.com> Sales@AngicGlobal.com

Metric 4.5mm Hex Male-Female Standoff

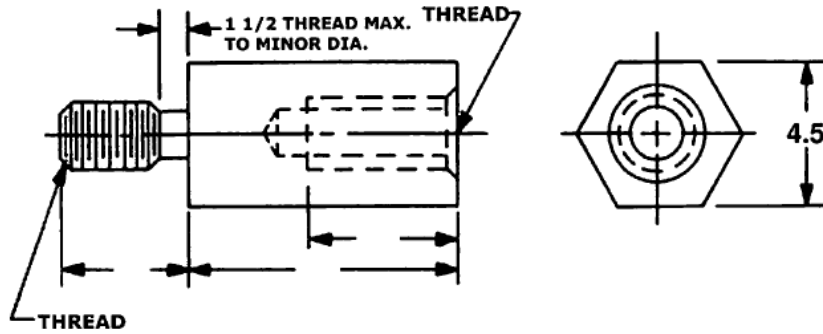

- Contact Sales Office for sizes not shown
- Source Control Drawing: To be produced by Fascomp Electronic Hardware

FMXXXX	Length (L)
FM2100	5
FM2101	6
FM2102	7
FM2103	8
FM2104	9
FM2105	10
FM2106	11
FM2107	12
FM2108	13
FM2109	14
FM2110	15
FM2111	16
FM2112	17
FM2113	18
FM2114	19
FM2115	20
FM2116	21
FM2117	22
FM2118	23
FM2119	24
FM2120	25
FM2121	28
FM2122	31
FM2123	34
FM2124	37
FM2125	40
FM2126	43
FM2127	46
FM2128	49
FM2129	52

Create a part number			
FCXXXX	XXXX	XX	XX
Length	Thread	Material	Finish

Thread			
Short lengths, 'A' tapped to maximum depth			
Thread Code (XXX)	Thread	Depth (A)	Length (B)
2545	M2.5x0.45	4.8	3.97
3005	M3x0.5	6.4	4.76

Material	
Material Code (XX)	
A	Aluminum
B	Brass
S	Steel
SS	Stainless Steel
N	Nylon

See page 3 for finish codes



Fascomp Electronic Hardware
 7814 Kingspointe Pkwy
 Orlando, FL 32819
 www.fascomp.com
 (407) 226-2112
 (407) 226-3370



Metric 6mm Hex Male-Female Standoff

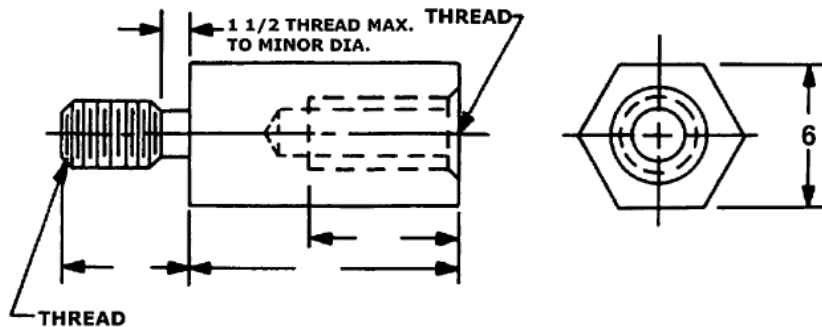

- Contact Sales Office for sizes not shown
- Source Control Drawing: To be produced by Fascomp Electronic Hardware

FMXXXX	Length (L)
FM2140	5
FM2141	6
FM2142	7
FM2143	8
FM2144	9
FM2145	10
FM2146	11
FM2147	12
FM2148	13
FM2149	14
FM2150	15
FM2151	16
FM2152	17
FM2153	18
FM2154	19
FM2155	20
FM2156	21
FM2157	22
FM2158	23
FM2159	24
FM2160	25
FM2161	28
FM2162	31
FM2163	34
FM2164	37
FM2165	40
FM2166	43
FM2167	46
FM2168	49
FM2169	52

Create a part number			
FCXXXX	XXXX	XX	XX
Length	Thread	Material	Finish

Thread			
Short lengths, 'A' tapped to maximum depth			
Thread Code (XXX)	Thread	Depth (A)	Length (B)
2545	M2.5x0.45	4.8	3.97
3005	M3x0.5	6.4	4.76
3506	M3.5x0.6	9.5	6.35
4007	M4x0.7	11.1	9.53

Material	
Material Code (XX)	
A	Aluminum
B	Brass
S	Steel
SS	Stainless Steel
N	Nylon

See page 3 for finish codes



Fascomp Electronic Hardware
 7814 Kingspointe Pkwy
 Orlando, FL 32819
 www.fascomp.com
 (407) 226-2112
 (407) 226-3370



Get quote >>

Angic Global Solutions 1-888-872-0690
<https://www.AngicGlobal.com> Sales@AngicGlobal.com

Metric 8mm Hex Male-Female Standoff

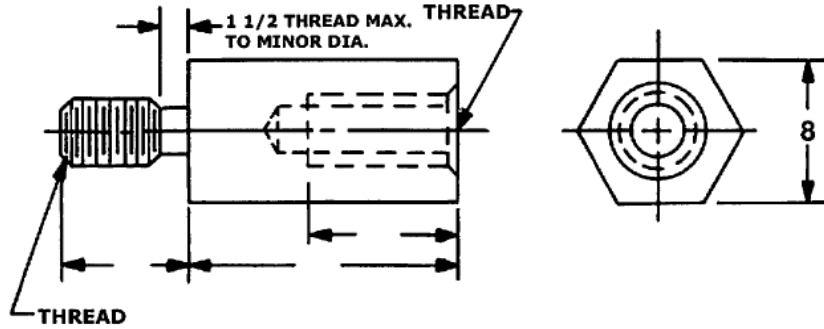

- Contact Sales Office for sizes not shown
- Source Control Drawing: To be produced by Fascomp Electronic Hardware

FMXXXX	Length (L)
FM2180	5
FM2181	6
FM2182	7
FM2183	8
FM2184	9
FM2185	10
FM2186	11
FM2187	12
FM2188	13
FM2189	14
FM2190	15
FM2191	16
FM2192	17
FM2193	18
FM2194	19
FM2195	20
FM2196	21
FM2197	22
FM2198	23
FM2199	24
FM2200	25
FM2201	28
FM2202	31
FM2203	34
FM2204	37
FM2205	40
FM2206	43
FM2207	46
FM2208	49
FM2209	52

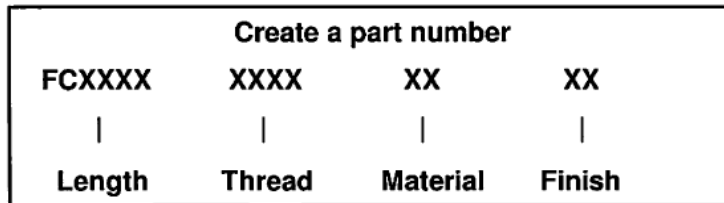

Thread			
Short lengths, 'A' tapped to maximum depth			
Thread Code (XXX)	Thread	Depth (A)	Length (B)
3005	M3x0.5	6.4	4.76
3506	M3.5x0.6	9.5	6.35
4007	M4x0.7	11.1	9.53
5008	M5x0.8	12.7	9.53

Material	
Material Code (XX)	
A	Aluminum
B	Brass
S	Steel
SS	Stainless Steel
N	Nylon

See page 3 for finish codes



Fascomp Electronic Hardware
 7814 Kingspointe Pkwy
 Orlando, FL 32819
 www.fascomp.com
 407) 226-2112
 407) 226-3370



Metric 10mm Hex Male-Female Standoff

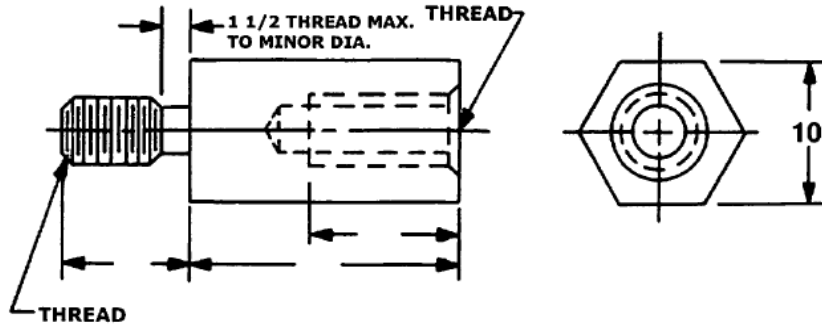

- Contact Sales Office for sizes not shown
- Source Control Drawing: To be produced by Fascomp Electronic Hardware

FMXXXX	Length (L)
FM2220	5
FM2221	6
FM2222	7
FM2223	8
FM2224	9
FM2225	10
FM2226	11
FM2227	12
FM2228	13
FM2229	14
FM2230	15
FM2231	16
FM2232	17
FM2233	18
FM2234	19
FM2235	20
FM2236	21
FM2237	22
FM2238	23
FM2239	24
FM2240	25
FM2241	28
FM2242	31
FM2243	34
FM2244	37
FM2245	40
FM2246	43
FM2247	46
FM2248	49
FM2249	52

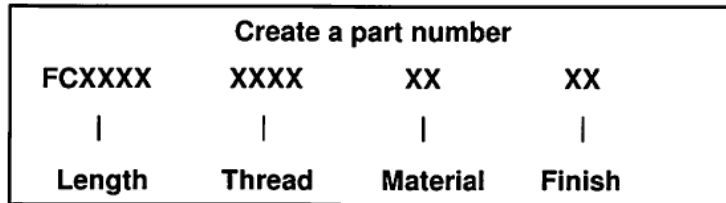

Thread			
Short lengths, 'A' tapped to maximum depth			
Thread Code (XXX)	Thread	Depth (A)	Length (B)
3005	M3x0.5	6.4	4.76
3506	M3.5x0.6	9.5	6.25
4007	M4x0.7	11.1	9.53
5008	M5x0.8	12.7	9.53

Material	
Material Code (XX)	
A	Aluminum
B	Brass
S	Steel
SS	Stainless Steel
N	Nylon

See page 3 for finish codes



Fascomp Electronic Hardware
 7814 Kingspointe Pkwy
 Orlando, FL 32819
 www.fascomp.com
 (407) 226-2112
 (407) 226-3370



Get quote »

Angic Global Solutions 1-888-872-0690
<https://www.AngicGlobal.com> Sales@AngicGlobal.com

Metric 13mm Hex Male-Female Standoff

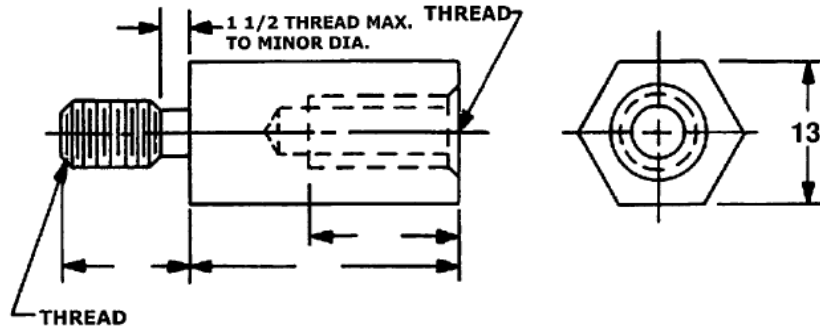

- Contact Sales Office for sizes not shown
- Source Control Drawing: To be produced by Fascomp Electronic Hardware

FMXXXX	Length (L)
FM2260	5
FM2261	6
FM2262	7
FM2263	8
FM2264	9
FM2265	10
FM2266	11
FM2267	12
FM2268	13
FM2269	14
FM2270	15
FM2271	16
FM2272	17
FM2273	18
FM2274	19
FM2275	20
FM2276	21
FM2277	22
FM2278	23
FM2279	24
FM2280	25
FM2281	28
FM2282	31
FM2283	34
FM2284	37
FM2285	40
FM2286	43
FM2287	46
FM2288	49
FM2289	52

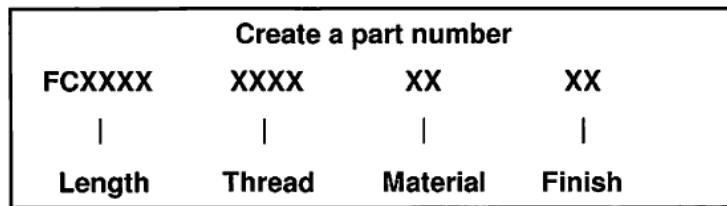

Thread			
Short lengths, 'A' tapped to maximum depth			
Thread Code (XXX)	Thread	Depth (A)	Length (B)
5008	M5x0.8	12.7	9.53
6010	M6x1	15	12.7
8012	M8x1.25	15	12.7

Material	
Material Code (XX)	
A	Aluminum
B	Brass
S	Steel
SS	Stainless Steel
N	Nylon

See page 3 for finish codes



Fascomp Electronic Hardware
 7814 Kingspointe Pkwy
 Orlando, FL 32819
 www.fascomp.com
 (407) 226-2112
 (407) 226-3370



FRACTION TO DECIMAL CONVERSION CHART

	<u>Inches</u>	<u>Millimeters</u>		<u>Inches</u>	<u>Millimeters</u>
$\frac{1}{32}$.015625	.3969	$\frac{33}{64}$.515625	13.0969
$\frac{1}{16}$.03125	.7938	$\frac{17}{32}$.53125	13.4938
$\frac{3}{64}$.046875	1.1906	$\frac{35}{64}$.546875	13.8907
$\frac{1}{8}$.0625	1.5875	$\frac{9}{16}$.5625	14.2876
$\frac{5}{64}$.078125	1.9844	$\frac{37}{64}$.578125	14.6844
$\frac{3}{32}$.09375	2.3813	$\frac{19}{32}$.59375	15.0813
$\frac{7}{64}$.109375	2.7781	$\frac{39}{64}$.609375	15.4782
$\frac{1}{4}$.125	.1750	$\frac{5}{8}$.625	15.8751
$\frac{9}{64}$.140625	3.5719	$\frac{41}{64}$.640625	16.2719
$\frac{5}{32}$.15625	3.9688	$\frac{21}{32}$.65625	16.6688
$\frac{11}{64}$.171875	4.3656	$\frac{43}{64}$.671875	17.0657
$\frac{3}{16}$.1875	4.7625	$\frac{11}{16}$.6875	17.4626
$\frac{13}{64}$.203125	5.1594	$\frac{45}{64}$.703125	17.8594
$\frac{7}{32}$.21875	5.5563	$\frac{23}{32}$.71875	18.2563
$\frac{15}{64}$.234375	5.9531	$\frac{47}{64}$.734375	18.6532
$\frac{1}{2}$.2506	.3500	$\frac{3}{4}$.750	19.0501
$\frac{17}{64}$.265625	6.7469	$\frac{49}{64}$.765625	19.4470
$\frac{9}{32}$.28125	7.1438	$\frac{25}{32}$.78125	19.8438
$\frac{19}{64}$.296875	7.5406	$\frac{51}{64}$.796875	20.2407
$\frac{5}{16}$.3125	7.9375	$\frac{13}{16}$.8125	20.6376
$\frac{21}{64}$.328125	8.3344	$\frac{53}{64}$.828125	21.0345
$\frac{11}{32}$.34375	8.7313	$\frac{27}{32}$.84375	21.4313
$\frac{23}{64}$.359375	9.1282	$\frac{55}{64}$.859375	21.8282
$\frac{3}{8}$.3759	.5250	$\frac{7}{8}$.875	22.2251
$\frac{25}{64}$.390625	9.9219	$\frac{57}{64}$.890625	22.6220
$\frac{13}{32}$.40625	10.3188	$\frac{29}{32}$.90625	23.0188
$\frac{27}{64}$.421875	10.7157	$\frac{59}{64}$.921875	23.4157
$\frac{7}{16}$.4375	11.1125	$\frac{15}{16}$.9375	23.8126
$\frac{29}{64}$.453125	11.5094	$\frac{61}{64}$.953125	24.2095
$\frac{15}{32}$.46875	11.9063	$\frac{31}{32}$.96875	24.6063
$\frac{31}{64}$.484375	12.3032	$\frac{63}{64}$.984375	25.0032
$\frac{1}{2}$.50012	.7001	1	1.000	25.4001



Get quote

Angic Global Solutions

1-888-872-0690

<https://www.AngicGlobal.com> Sales@AngicGlobal.com

SHOULDER SCREW

MALE-FEMALE STANDOFFS

SPACERS

HANDLES

SWAGES

"The Good Guys"

Fascomp
electronic hardware

FEMALE STANDOFFS

CAPTIVE SCREWS

JACKSCREWS

CUSTOM DESIGNS

THUMBSCREWS

FLORIDA SALES OFFICE
7814 KINGSPONTE PARKWAY
ORLANDO, FLORIDA 32819
TEL: (407) 226-2112
FAX: (407) 226-3370

CONNECTICUT SALES OFFICE
550 SPRING STREET
NAUGATUCK, CONNECTICUT 06770
TEL: (203) 720-1146
FAX: (203) 720-1156

ISO 9001:2008