

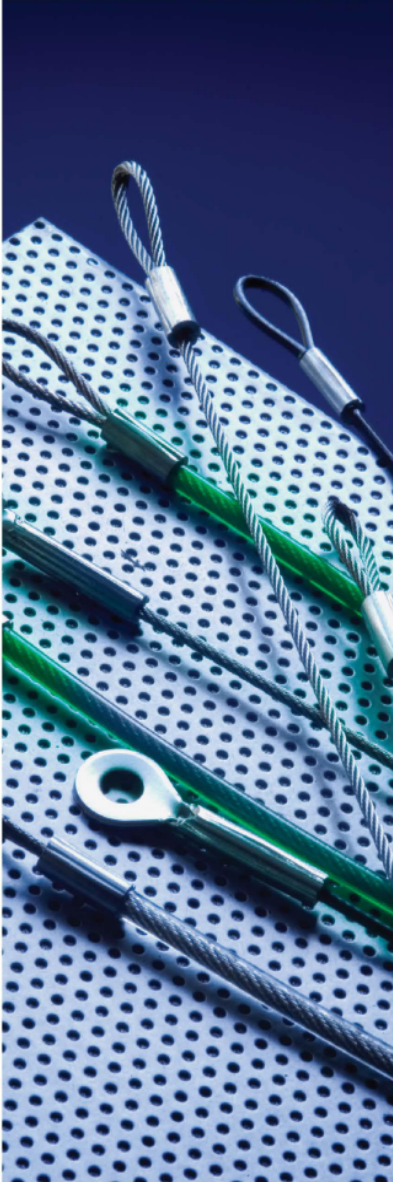

# Quick Release Ball Lock Pins.

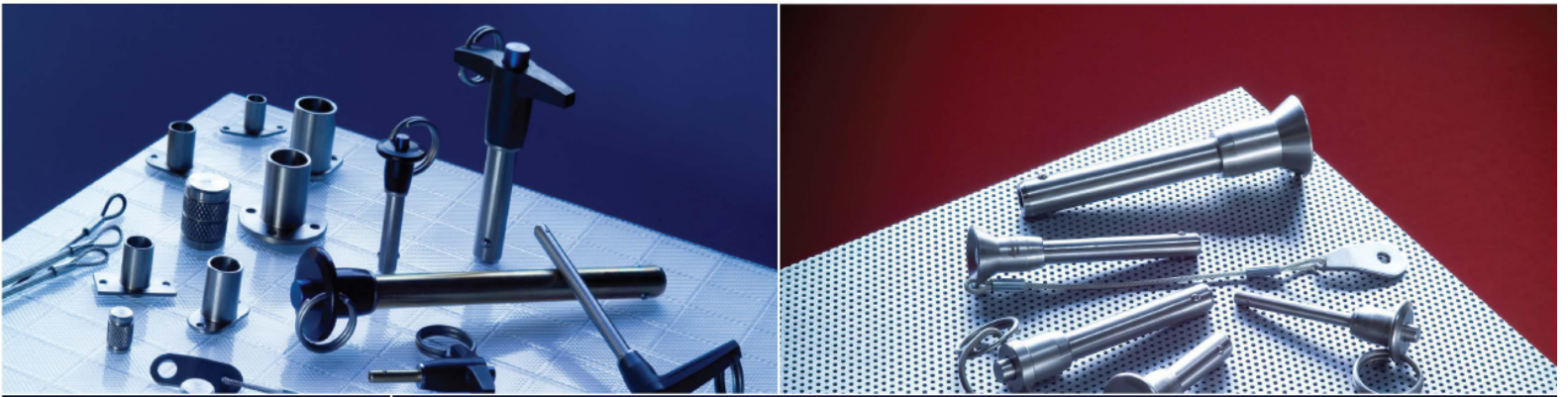

Get quote >>

[www.fairlane.com](http://www.fairlane.com)

Angic Global Solutions

<https://www.AngicGlobal.com>

1-888-872-0690

[Sales@AngicGlobal.com](mailto:Sales@AngicGlobal.com)

**INDEX**



T-Handle .....4-7

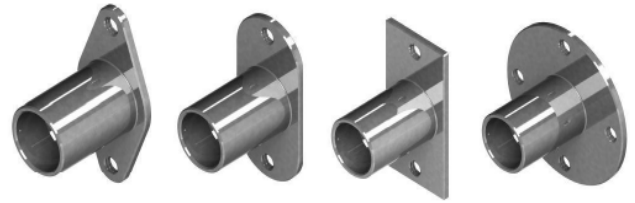

Receptacles .....40



L-Handle .....8-11

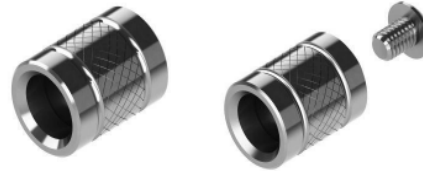

End Caps .....41

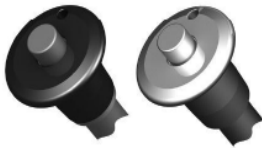

Button Handle .....12-19



Wire Lanyards .....42-43



Ring Handle .....20-27

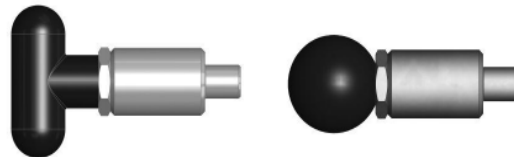

Pull Pins .....44



Nautical Handle .....28-31



Dome Handle .....32-39

### Selecting the proper Quick Release Ball Lock Pin

#### 1. Select the proper pin diameter.

Our standard inch sizes are 3/16", 1/4", 5/16", 3/8", 1/2" and 5/8". Our standard metric sizes are 5mm, 6mm, 8mm, 10mm, 12mm and 16mm. We also offer 3/4", 7/8" and 1" diameters as special order.

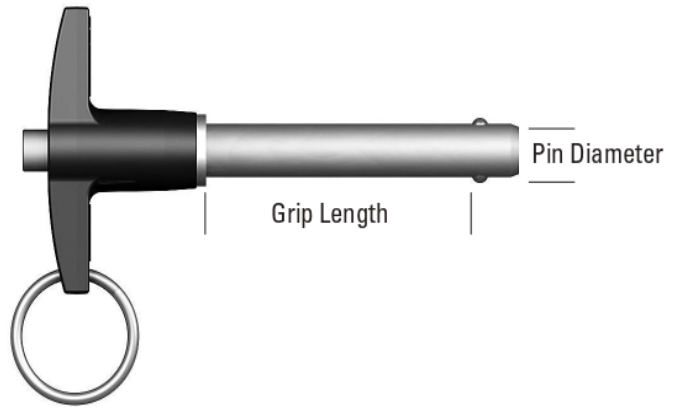

#### 2. Select the proper grip length.

The grip length (also referred to as the useable length) is measured from the bottom of the handle to the top of the locking balls. Our standard inch grip lengths range from 1/2" up to 6" and our metric grip lengths range from 10mm up to 100mm depending on the diameter. Custom lengths are also available.

#### 3. Select the proper shank material.

**17-4 SS** – Made from heat treated 17-4 stainless steel, they are designed for applications where higher shear strengths are required. Because they are made from stainless steel, they offer superior corrosion resistance over alloy steel. This combination of strength and corrosion resistance makes it a good choice for a wide range of demanding applications. RoHS compliant.

**300 Series Stainless Steel** – Made from 300 series stainless, **these pins are not designed to be used where shear strengths are demanding.** While these pins offer lower shear strengths than other materials, they are strong enough to meet the needs for many applications. This material also offers very good corrosion resistance. RoHS compliant.

**4130 Alloy Steel** – Made from heat treated and plated 4130 alloy steel, these pins are ideal where high strength is required and environmental factors are not an issue. Metric sizes are RoHS compliant.

#### 4. Select the proper handle style.

Handle choice is based on clearance, use and appearance. Our handles are made from either aluminum alloy or stainless steel. The aluminum handles are anodized or E coated black and are available in Ring, Button, L, T, and Domed configurations. Stainless handles are available in Ring, Button, Nautical Recessed, and Domed configurations.

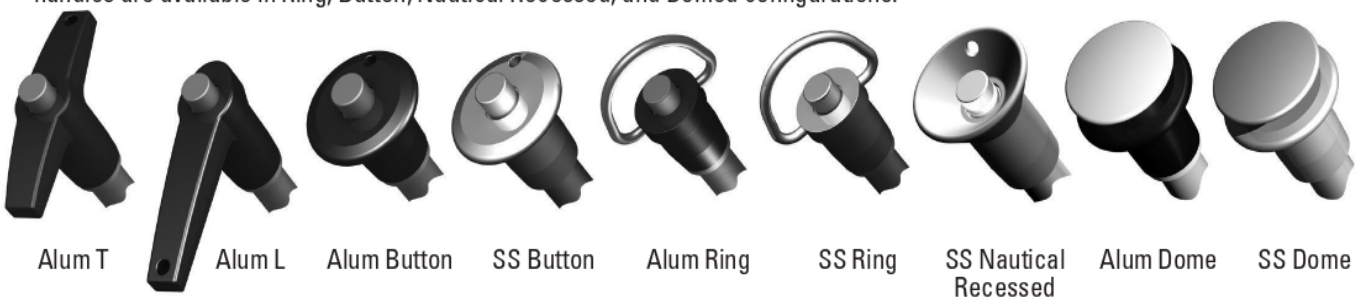

#### 5. Select lanyard assembly.

Lanyard assemblies are used to attach the pin to a fixture so it does not get misplaced while the pin is not in use. The lanyard assemblies must be ordered separately. See pages 42 and 43 for our standard assemblies.



## QUICK RELEASE BALL LOCK PINS

### Material Specifications

for the Fairlane pins shown in this catalog.

	17-4 SS PINS	300 SERIES SS PINS	STEEL ALLOY 4130 PINS
SHANK – Inch	CRES 17-4PH (Stainless Steel) (AMS-5643) (UNS S17400) (DIN 1.4542) Heat Treated Min. RC-40 Tensile Strength = 190,000 lb/in <sup>2</sup> Minimum Passivated Finish	CRES 304 (Stainless Steel) (AMS-5639) (UNS S530400) (DIN 1.4301) or CRES 303 (Stainless Steel) (AMS-5640) (UNS S30300) (DIN 1.4305) Tensile Strength = 73,000 lb/in <sup>2</sup> Minimum Passivated Finish	4130 (Alloy Steel) (AMS-6370) (UNS G41300) (DIN 1.7218) Heat Treated RC36-40 Tensile Strength = 160,000 to 180,000 lb/in <sup>2</sup> Cadmium Plate Finish
SHANK – Metric	CRES 17-4PH (Stainless Steel) (AMS-5643) (UNS S17400) (DIN 1.4542) Heat Treated Min. RC-40 Tensile Strength = 190,000 lb/in <sup>2</sup> Minimum Passivated Finish	—————	4130 (Alloy Steel) (AMS-6370) (UNS G41300) (DIN 1.7218) Heat Treated RC36-40 Tensile Strength = 160,000 to 180,000 lb/in <sup>2</sup> Zinc Plated Clear Chromate
SPINDLE (Internal)	CRES 17-4PH (Stainless Steel) (AMS-5643) (UNS S17400) (DIN 1.4542) Heat Treated Min. RC-40 Tensile Strength = 190,000 lb/in <sup>2</sup> Minimum Passivated Finish	CRES 17-4PH (Stainless Steel) (AMS-5643) (UNS S17400) (DIN 1.4542) Heat Treated Min. RC-40 Tensile Strength = 190,000 lb/in <sup>2</sup> Minimum Passivated Finish	CRES 17-4PH (Stainless Steel) (AMS-5643) (UNS S17400) (DIN 1.4542) Heat Treated Min. RC-40 Tensile Strength = 190,000 lb/in <sup>2</sup> Minimum Passivated Finish
HANDLES (Aluminum Ring, Button, & Domed)	Aluminum 2024-T4 (ASTM-B211) (UNS A92024) (DIN AlCuMg2) Anodized Finish (Black)	Aluminum 2024-T4 (ASTM-B211) (UNS A92024) (DIN AlCuMg2) Anodized Finish (Black)	Aluminum 2024-T4 (ASTM-B211) (UNS A92024) (DIN AlCuMg2) Anodized Finish (Black)
HANDLES (Stainless Ring, Button, Nautical Recessed, & Domed)	CRES 303 Stainless Steel (ASTM-A581) (UNS S30300) (DIN 1.4305) Passivated Finish	CRES 303 Stainless Steel (ASTM-A581) (UNS S30300) (DIN 1.4305) Passivated Finish	—————
HANDLES (T & L)	Aluminum 380 Die Cast (ASTM-B85) (UNS A03800) (DIN AISi9Cu3) Anodized Finish or E Coat (Black)	Aluminum 380 Die Cast (ASTM-B85) (UNS A03800) (DIN AISi9Cu3) Anodized Finish or E Coat (Black)	Aluminum 380 Die Cast (ASTM-B85) (UNS A03800) (DIN AISi9Cu3) Anodized Finish or E Coat (Black)
WEAR COLLAR	CRES 303 (Stainless Steel) (ASTM-A581) (UNS S30300) (DIN 1.4305) Passivated Finish	CRES 303 (Stainless Steel) (ASTM-A581) (UNS S30300) (DIN 1.4305) Passivated Finish	CRES 303 (Stainless Steel) (ASTM-A581) (UNS S30300) (DIN 1.4305) Passivated Finish
ACTUATOR BUTTON*	Aluminum 2024-T4 (ASTM-B211) (UNS A92024) (DIN AlCuMg2) Anodized Finish (Blue)	Aluminum 2024-T4 (ASTM-B211) (UNS A92024) (DIN AlCuMg2) Anodized Finish (Blue)	Aluminum 2024-T4 (ASTM-B211) (UNS A92024) (DIN AlCuMg2) Anodized Finish (Blue)
ACTUATOR BUTTON* (Aluminum Dome)	Aluminum 2024-T4 (ASTM-B211) (UNS A92024) (DIN AlCuMg2) Anodized Finish (Clear)	Aluminum 2024-T4 (ASTM-B211) (UNS A92024) (DIN AlCuMg2) Anodized Finish (Clear)	Aluminum 2024-T4 (ASTM-B211) (UNS A92024) (DIN AlCuMg2) Anodized Finish (Clear)
SPRING (Internal)	CRES 302 (Stainless Steel) (ASTM-A313) (UNS S30200) (DIN 1.4300) Passivated Finish	CRES 302 (Stainless Steel) (ASTM-A313) (UNS S30200) (DIN 1.4300) Passivated Finish	CRES 302 (Stainless Steel) (ASTM-A313) (UNS S30200) (DIN 1.4300) Passivated Finish
BALLS	CRES 440C (Stainless Steel) (QQ-S-763) (UNS S44004) (DIN 1.4125) Heat Treated -RC (58-62) Passivated Finish	CRES 440C (Stainless Steel) (QQ-S-763) (UNS S44004) (DIN 1.4125) Heat Treated -RC (58-62) Passivated Finish	CRES 440C (Stainless Steel) (QQ-S-763) (UNS S44004) (DIN 1.4125) Heat Treated -RC (58-62) Passivated Finish
BAIL (Ring Handle)	CRES 302 (Stainless Steel) (ASTM-A313) (UNS S30200) (DIN 1.4300) Passivated Finish	CRES 302 (Stainless Steel) (ASTM-A313) (UNS S30200) (DIN 1.4300) Passivated Finish	CRES 302 (Stainless Steel) (ASTM-A313) (UNS S30200) (DIN 1.4300) Passivated Finish
SPLIT RING	CRES 302 (Stainless Steel) (ASTM-A313) (UNS S30200) (DIN 1.4300) Passivated Finish	CRES 302 (Stainless Steel) (ASTM-A313) (UNS S30200) (DIN 1.4300) Passivated Finish	CRES 302 (Stainless Steel) (ASTM-A313) (UNS S30200) (DIN 1.4300) Passivated Finish

\*Note: When a stainless Ring, Button, Nautical Recessed, or Domed handle is specified, the actuator button will be made from CRES-303 (Stainless).

### Hole Size / Performance Data

#### Inch

Dia	Hole Size		Min. Pull-Out Strength (lbs)	Calculated Double Shear (lbs)		
	Max	Min		4130 Steel	17-4 Stainless	300 Series SS*
3/16	.1940	.1900	200	4,600	5,150	—
1/4	.2540	.2500	230	8,200	9,200	2,200
5/16	.3165	.3125	510	12,800	14,400	3,500
3/8	.3790	.3750	575	18,400	20,600	4,500
1/2	.5050	.5000	1,160	32,800	36,800	11,500
5/8	.6300	.6250	2,070	51,200	57,500	—

\*Note: 300 Series Stainless is not recommended in applications where shear forces are a factor.

#### Metric

Dia	Hole Size		Min. Pull-Out Strength (N)	Calculated Double Shear (N)	
	Max	Min		4130 Steel	17-4 Stainless
5	5.1	5.0	890	21,600	24,400
6	6.1	6.0	1,023	31,686	35,640
8	8.1	8.0	2,268	56,712	63,804
10	10.1	10.0	2,558	88,977	100,101
12	12.1	12.0	5,160	128,050	144,060
16	16.1	16.0	9,207	228,602	257,179

## QUICK RELEASE BALL LOCK PINS

### T-Handle | Inch

**MA** MODIFICATIONS AVAILABLE

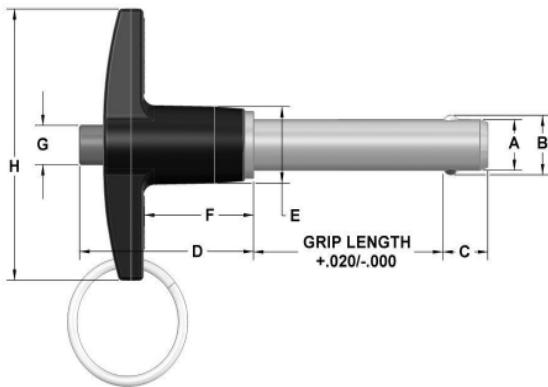

Dia	Hole Size		Min. Pull-Out Strength (lbs)	Calculated Double Shear (lbs)		
	Max	Min		4130 Steel	17-4 Stainless	300 Series SS*
3/16	.1940	.1900	200	4,600	5,150	—
1/4	.2540	.2500	230	8,200	9,200	2,200
5/16	.3165	.3125	510	12,800	14,400	3,500
3/8	.3790	.3750	575	18,400	20,600	4,500
1/2	.5050	.5000	1,160	32,800	36,800	11,500
5/8	.6300	.6250	2,070	51,200	57,500	—

\*Note: 300 Series Stainless is not recommended in applications where shear forces are a factor.

These positive locking quick release pins have a wide range of uses in fastening, locating, and alignment applications. The pins will not release until the button on the handle is depressed. Once the button is depressed, the balls retract into the shank allowing the pin to be inserted or removed into or out of a hole. They are available in three shank materials to meet your application. The handles for the pins listed below are made from 380 aluminum casting with a black finish. The pins are supplied with a stainless steel split ring for attaching a cable assembly. In addition to the standard sizes shown below, custom solutions and additional sizes are available as special order. See page 3 for complete specifications.

4130 Steel Part #	17-4 SS Part #	300 Series SS Part #	Nominal Diameter	A Max	A Min	Grip Length	+/- .005 B	+ .000/- .030 C	D	E	F	G	H
TAAS-18-050	TACH-18-050	—	3/16	.1885	.1870	.50	.220	.260	1.21	.47	.76	.23	1.81
TAAS-18-075	TACH-18-075	—	3/16	.1885	.1870	.75	.220	.260	1.21	.47	.76	.23	1.81
TAAS-18-100	TACH-18-100	—	3/16	.1885	.1870	1.00	.220	.260	1.21	.47	.76	.23	1.81
TAAS-18-125	TACH-18-125	—	3/16	.1885	.1870	1.25	.220	.260	1.21	.47	.76	.23	1.81
TAAS-18-150	TACH-18-150	—	3/16	.1885	.1870	1.50	.220	.260	1.21	.47	.76	.23	1.81
TAAS-18-175	TACH-18-175	—	3/16	.1885	.1870	1.75	.220	.260	1.21	.47	.76	.23	1.81
TAAS-18-200	TACH-18-200	—	3/16	.1885	.1870	2.00	.220	.260	1.21	.47	.76	.23	1.81
TAAS-18-250	TACH-18-250	—	3/16	.1885	.1870	2.50	.220	.260	1.21	.47	.76	.23	1.81
TAAS-18-300	TACH-18-300	—	3/16	.1885	.1870	3.00	.220	.260	1.21	.47	.76	.23	1.81
TAAS-18-350	TACH-18-350	—	3/16	.1885	.1870	3.50	.220	.260	1.21	.47	.76	.23	1.81
TAAS-18-400	TACH-18-400	—	3/16	.1885	.1870	4.00	.220	.260	1.21	.47	.76	.23	1.81
TAAS-25-050	TACH-25-050	TACS-25-050	1/4	.2485	.2470	.50	.289	.290	1.21	.47	.76	.23	1.81
TAAS-25-075	TACH-25-075	TACS-25-075	1/4	.2485	.2470	.75	.289	.290	1.21	.47	.76	.23	1.81
TAAS-25-100	TACH-25-100	TACS-25-100	1/4	.2485	.2470	1.00	.289	.290	1.21	.47	.76	.23	1.81
TAAS-25-125	TACH-25-125	TACS-25-125	1/4	.2485	.2470	1.25	.289	.290	1.21	.47	.76	.23	1.81
TAAS-25-150	TACH-25-150	TACS-25-150	1/4	.2485	.2470	1.50	.289	.290	1.21	.47	.76	.23	1.81
TAAS-25-175	TACH-25-175	TACS-25-175	1/4	.2485	.2470	1.75	.289	.290	1.21	.47	.76	.23	1.81
TAAS-25-200	TACH-25-200	TACS-25-200	1/4	.2485	.2470	2.00	.289	.290	1.21	.47	.76	.23	1.81
TAAS-25-250	TACH-25-250	TACS-25-250	1/4	.2485	.2470	2.50	.289	.290	1.21	.47	.76	.23	1.81
TAAS-25-300	TACH-25-300	TACS-25-300	1/4	.2485	.2470	3.00	.289	.290	1.21	.47	.76	.23	1.81
TAAS-25-350	TACH-25-350	TACS-25-350	1/4	.2485	.2470	3.50	.289	.290	1.21	.47	.76	.23	1.81
TAAS-25-400	TACH-25-400	TACS-25-400	1/4	.2485	.2470	4.00	.289	.290	1.21	.47	.76	.23	1.81
TAAS-31-050	TACH-31-050	TACS-31-050	5/16	.3110	.3095	.50	.375	.330	1.21	.47	.76	.23	1.81
TAAS-31-075	TACH-31-075	TACS-31-075	5/16	.3110	.3095	.75	.375	.330	1.21	.47	.76	.23	1.81
TAAS-31-100	TACH-31-100	TACS-31-100	5/16	.3110	.3095	1.00	.375	.330	1.21	.47	.76	.23	1.81
TAAS-31-125	TACH-31-125	TACS-31-125	5/16	.3110	.3095	1.25	.375	.330	1.21	.47	.76	.23	1.81
TAAS-31-150	TACH-31-150	TACS-31-150	5/16	.3110	.3095	1.50	.375	.330	1.21	.47	.76	.23	1.81
TAAS-31-175	TACH-31-175	TACS-31-175	5/16	.3110	.3095	1.75	.375	.330	1.21	.47	.76	.23	1.81
TAAS-31-200	TACH-31-200	TACS-31-200	5/16	.3110	.3095	2.00	.375	.330	1.21	.47	.76	.23	1.81
TAAS-31-250	TACH-31-250	TACS-31-250	5/16	.3110	.3095	2.50	.375	.330	1.21	.47	.76	.23	1.81
TAAS-31-300	TACH-31-300	TACS-31-300	5/16	.3110	.3095	3.00	.375	.330	1.21	.47	.76	.23	1.81
TAAS-31-350	TACH-31-350	TACS-31-350	5/16	.3110	.3095	3.50	.375	.330	1.21	.47	.76	.23	1.81
TAAS-31-400	TACH-31-400	TACS-31-400	5/16	.3110	.3095	4.00	.375	.330	1.21	.47	.76	.23	1.81



# QUICK RELEASE BALL LOCK PINS

## T-Handle | Inch (continued)

**MA** MODIFICATIONS AVAILABLE

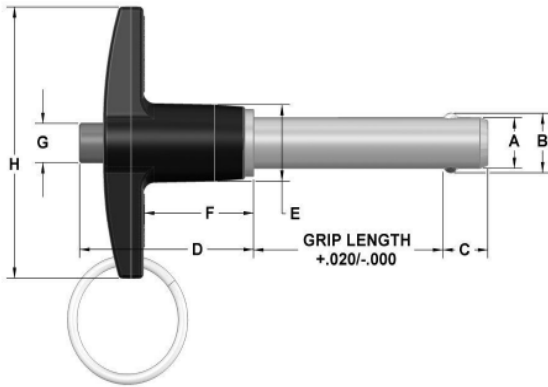

Dia	Hole Size		Min. Pull-Out Strength (lbs)	Calculated Double Shear (lbs)		
	Max	Min		4130 Steel	17-4 Stainless	300 Series SS*
3/16	.1940	.1900	200	4,600	5,150	—
1/4	.2540	.2500	230	8,200	9,200	2,200
5/16	.3165	.3125	510	12,800	14,400	3,500
3/8	.3790	.3750	575	18,400	20,600	4,500
1/2	.5050	.5000	1,160	32,800	36,800	11,500
5/8	.6300	.6250	2,070	51,200	57,500	—

\*Note: 300 Series Stainless is not recommended in applications where shear forces are a factor.

4130 Steel Part #	17-4 SS Part #	300 Series SS Part #	Nominal Diameter	A Max	A Min	Grip Length	+/- .005 B	+ .000/- .030 C	D	E	F	G	H
TAAS-37-050	TACH-37-050	TACS-37-050	3/8	.3735	.3720	.50	.440	.365	1.37	.56	.87	.29	2.00
TAAS-37-075	TACH-37-075	TACS-37-075	3/8	.3735	.3720	.75	.440	.365	1.37	.56	.87	.29	2.00
TAAS-37-100	TACH-37-100	TACS-37-100	3/8	.3735	.3720	1.00	.440	.365	1.37	.56	.87	.29	2.00
TAAS-37-125	TACH-37-125	TACS-37-125	3/8	.3735	.3720	1.25	.440	.365	1.37	.56	.87	.29	2.00
TAAS-37-150	TACH-37-150	TACS-37-150	3/8	.3735	.3720	1.50	.440	.365	1.37	.56	.87	.29	2.00
TAAS-37-175	TACH-37-175	TACS-37-175	3/8	.3735	.3720	1.75	.440	.365	1.37	.56	.87	.29	2.00
TAAS-37-200	TACH-37-200	TACS-37-200	3/8	.3735	.3720	2.00	.440	.365	1.37	.56	.87	.29	2.00
TAAS-37-250	TACH-37-250	TACS-37-250	3/8	.3735	.3720	2.50	.440	.365	1.37	.56	.87	.29	2.00
TAAS-37-300	TACH-37-300	TACS-37-300	3/8	.3735	.3720	3.00	.440	.365	1.37	.56	.87	.29	2.00
TAAS-37-350	TACH-37-350	TACS-37-350	3/8	.3735	.3720	3.50	.440	.365	1.37	.56	.87	.29	2.00
TAAS-37-400	TACH-37-400	TACS-37-400	3/8	.3735	.3720	4.00	.440	.365	1.37	.56	.87	.29	2.00
TAAS-50-100	TACH-50-100	TACS-50-100	1/2	.4985	.4970	1.00	.594	.460	1.60	.72	1.00	.42	2.25
TAAS-50-125	TACH-50-125	TACS-50-125	1/2	.4985	.4970	1.25	.594	.460	1.60	.72	1.00	.42	2.25
TAAS-50-150	TACH-50-150	TACS-50-150	1/2	.4985	.4970	1.50	.594	.460	1.60	.72	1.00	.42	2.25
TAAS-50-175	TACH-50-175	TACS-50-175	1/2	.4985	.4970	1.75	.594	.460	1.60	.72	1.00	.42	2.25
TAAS-50-200	TACH-50-200	TACS-50-200	1/2	.4985	.4970	2.00	.594	.460	1.60	.72	1.00	.42	2.25
TAAS-50-250	TACH-50-250	TACS-50-250	1/2	.4985	.4970	2.50	.594	.460	1.60	.72	1.00	.42	2.25
TAAS-50-300	TACH-50-300	TACS-50-300	1/2	.4985	.4970	3.00	.594	.460	1.60	.72	1.00	.42	2.25
TAAS-50-350	TACH-50-350	TACS-50-350	1/2	.4985	.4970	3.50	.594	.460	1.60	.72	1.00	.42	2.25
TAAS-50-400	TACH-50-400	TACS-50-400	1/2	.4985	.4970	4.00	.594	.460	1.60	.72	1.00	.42	2.25
TAAS-50-450	TACH-50-450	TACS-50-450	1/2	.4985	.4970	4.50	.594	.460	1.60	.72	1.00	.42	2.25
TAAS-50-500	TACH-50-500	TACS-50-500	1/2	.4985	.4970	5.00	.594	.460	1.60	.72	1.00	.42	2.25
TAAS-50-550	TACH-50-550	TACS-50-550	1/2	.4985	.4970	5.50	.594	.460	1.60	.72	1.00	.42	2.25
TAAS-50-600	TACH-50-600	TACS-50-600	1/2	.4985	.4970	6.00	.594	.460	1.60	.72	1.00	.42	2.25
TAAS-62-150	TACH-62-150	—	5/8	.6235	.6220	1.50	.750	.580	1.77	.94	1.11	.54	3.07
TAAS-62-175	TACH-62-175	—	5/8	.6235	.6220	1.75	.750	.580	1.77	.94	1.11	.54	3.07
TAAS-62-200	TACH-62-200	—	5/8	.6235	.6220	2.00	.750	.580	1.77	.94	1.11	.54	3.07
TAAS-62-250	TACH-62-250	—	5/8	.6235	.6220	2.50	.750	.580	1.77	.94	1.11	.54	3.07
TAAS-62-300	TACH-62-300	—	5/8	.6235	.6220	3.00	.750	.580	1.77	.94	1.11	.54	3.07
TAAS-62-350	TACH-62-350	—	5/8	.6235	.6220	3.50	.750	.580	1.77	.94	1.11	.54	3.07
TAAS-62-400	TACH-62-400	—	5/8	.6235	.6220	4.00	.750	.580	1.77	.94	1.11	.54	3.07
TAAS-62-450	TACH-62-450	—	5/8	.6235	.6220	4.50	.750	.580	1.77	.94	1.11	.54	3.07
TAAS-62-500	TACH-62-500	—	5/8	.6235	.6220	5.00	.750	.580	1.77	.94	1.11	.54	3.07
TAAS-62-550	TACH-62-550	—	5/8	.6235	.6220	5.50	.750	.580	1.77	.94	1.11	.54	3.07
TAAS-62-600	TACH-62-600	—	5/8	.6235	.6220	6.00	.750	.580	1.77	.94	1.11	.54	3.07

## QUICK RELEASE BALL LOCK PINS

### T-Handle | Metric

**MA** MODIFICATIONS AVAILABLE

**EXPANDED LINE**

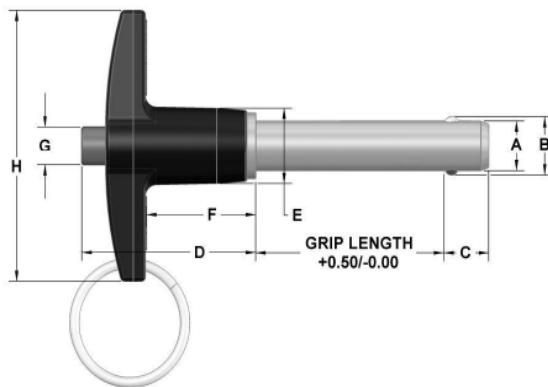

Dia mm	Hole Size		Min. Pull-Out Strength (N)	Calculated Double Shear (N)	
	Max mm	Min mm		4130 Steel	17-4 Stainless
5	5.1	5.0	890	21,600	24,400
6	6.1	6.0	1,023	31,686	35,640
8	8.1	8.0	2,268	56,712	63,804
10	10.1	10.0	2,558	88,977	100,101
12	12.1	12.0	5,160	128,050	144,060
16	16.1	16.0	9,207	228,602	257,179

These positive locking quick release pins have a wide range of uses in fastening, locating, and alignment applications. The pins will not release until the button on the handle is depressed. Once the button is depressed, the balls retract into the shank allowing the pin to be inserted or removed into or out of a hole. The shanks are available in 4130 steel with zinc plating or 17-4PH stainless steel. The handles for the pins listed below are made from 380 aluminum casting with a black finish. The pins are supplied with a stainless steel split ring for attaching a cable assembly. For specific application requirements, custom modifications are available for this product line. See page 3 for complete specifications. RoHS compliant.

4130 Steel Part #	17-4 SS Part #	Nominal Diameter mm	A Max mm	A Min mm	Grip Length mm	+/-0.25 B mm	+/-1.0 C mm	D mm	E mm	F mm	G mm	H mm
MTAAS-05-010	MTACH-05-010	5	4.96	4.92	10	5.54	6	30.7	11.9	19.3	5.8	46
MTAAS-05-015	MTACH-05-015	5	4.96	4.92	15	5.54	6	30.7	11.9	19.3	5.8	46
MTAAS-05-020	MTACH-05-020	5	4.96	4.92	20	5.54	6	30.7	11.9	19.3	5.8	46
MTAAS-05-025	MTACH-05-025	5	4.96	4.92	25	5.54	6	30.7	11.9	19.3	5.8	46
MTAAS-05-030	MTACH-05-030	5	4.96	4.92	30	5.54	6	30.7	11.9	19.3	5.8	46
MTAAS-05-035	MTACH-05-035	5	4.96	4.92	35	5.54	6	30.7	11.9	19.3	5.8	46
MTAAS-05-040	MTACH-05-040	5	4.96	4.92	40	5.54	6	30.7	11.9	19.3	5.8	46
MTAAS-05-045	MTACH-05-045	5	4.96	4.92	45	5.54	6	30.7	11.9	19.3	5.8	46
MTAAS-05-050	MTACH-05-050	5	4.96	4.92	50	5.54	6	30.7	11.9	19.3	5.8	46
MTAAS-05-060	MTACH-05-060	5	4.96	4.92	60	5.54	6	30.7	11.9	19.3	5.8	46
MTAAS-05-070	MTACH-05-070	5	4.96	4.92	70	5.54	6	30.7	11.9	19.3	5.8	46
MTAAS-05-080	MTACH-05-080	5	4.96	4.92	80	5.54	6	30.7	11.9	19.3	5.8	46
MTAAS-05-090	MTACH-05-090	5	4.96	4.92	90	5.54	6	30.7	11.9	19.3	5.8	46
MTAAS-05-100	MTACH-05-100	5	4.96	4.92	100	5.54	6	30.7	11.9	19.3	5.8	46
MTAAS-06-010	MTACH-06-010	6	5.96	5.92	10	6.99	7	30.7	11.9	19.3	5.8	46
MTAAS-06-015	MTACH-06-015	6	5.96	5.92	15	6.99	7	30.7	11.9	19.3	5.8	46
MTAAS-06-020	MTACH-06-020	6	5.96	5.92	20	6.99	7	30.7	11.9	19.3	5.8	46
MTAAS-06-025	MTACH-06-025	6	5.96	5.92	25	6.99	7	30.7	11.9	19.3	5.8	46
MTAAS-06-030	MTACH-06-030	6	5.96	5.92	30	6.99	7	30.7	11.9	19.3	5.8	46
MTAAS-06-035	MTACH-06-035	6	5.96	5.92	35	6.99	7	30.7	11.9	19.3	5.8	46
MTAAS-06-040	MTACH-06-040	6	5.96	5.92	40	6.99	7	30.7	11.9	19.3	5.8	46
MTAAS-06-045	MTACH-06-045	6	5.96	5.92	45	6.99	7	30.7	11.9	19.3	5.8	46
MTAAS-06-050	MTACH-06-050	6	5.96	5.92	50	6.99	7	30.7	11.9	19.3	5.8	46
MTAAS-06-060	MTACH-06-060	6	5.96	5.92	60	6.99	7	30.7	11.9	19.3	5.8	46
MTAAS-06-070	MTACH-06-070	6	5.96	5.92	70	6.99	7	30.7	11.9	19.3	5.8	46
MTAAS-06-080	MTACH-06-080	6	5.96	5.92	80	6.99	7	30.7	11.9	19.3	5.8	46
MTAAS-06-090	MTACH-06-090	6	5.96	5.92	90	6.99	7	30.7	11.9	19.3	5.8	46
MTAAS-06-100	MTACH-06-100	6	5.96	5.92	100	6.99	7	30.7	11.9	19.3	5.8	46
MTAAS-08-010	MTACH-08-010	8	7.96	7.92	10	9.42	8	30.7	11.9	19.3	5.8	46
MTAAS-08-015	MTACH-08-015	8	7.96	7.92	15	9.42	8	30.7	11.9	19.3	5.8	46
MTAAS-08-020	MTACH-08-020	8	7.96	7.92	20	9.42	8	30.7	11.9	19.3	5.8	46
MTAAS-08-025	MTACH-08-025	8	7.96	7.92	25	9.42	8	30.7	11.9	19.3	5.8	46
MTAAS-08-030	MTACH-08-030	8	7.96	7.92	30	9.42	8	30.7	11.9	19.3	5.8	46
MTAAS-08-035	MTACH-08-035	8	7.96	7.92	35	9.42	8	30.7	11.9	19.3	5.8	46
MTAAS-08-040	MTACH-08-040	8	7.96	7.92	40	9.42	8	30.7	11.9	19.3	5.8	46
MTAAS-08-045	MTACH-08-045	8	7.96	7.92	45	9.42	8	30.7	11.9	19.3	5.8	46
MTAAS-08-050	MTACH-08-050	8	7.96	7.92	50	9.42	8	30.7	11.9	19.3	5.8	46
MTAAS-08-060	MTACH-08-060	8	7.96	7.92	60	9.42	8	30.7	11.9	19.3	5.8	46
MTAAS-08-070	MTACH-08-070	8	7.96	7.92	70	9.42	8	30.7	11.9	19.3	5.8	46
MTAAS-08-080	MTACH-08-080	8	7.96	7.92	80	9.42	8	30.7	11.9	19.3	5.8	46
MTAAS-08-090	MTACH-08-090	8	7.96	7.92	90	9.42	8	30.7	11.9	19.3	5.8	46
MTAAS-08-100	MTACH-08-100	8	7.96	7.92	100	9.42	8	30.7	11.9	19.3	5.8	46



# QUICK RELEASE BALL LOCK PINS

## T-Handle | Metric (continued)

**MA** MODIFICATIONS AVAILABLE

**EXPANDED LINE**

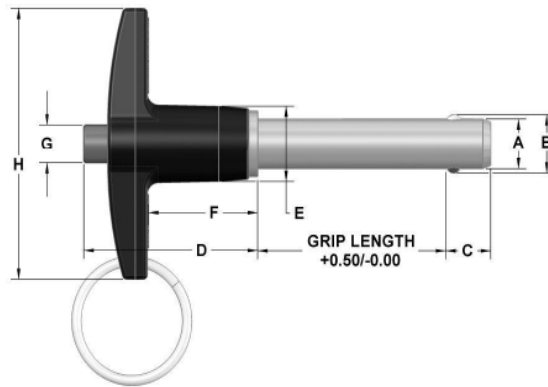

Dia mm	Hole Size mm		Min. Pull-Out Strength (N)	Calculated Double Shear (N)	
	Max	Min		4130 Steel	17-4 Stainless
5	5.1	5.0	890	21,600	24,400
6	6.1	6.0	1,023	31,686	35,640
8	8.1	8.0	2,268	56,712	63,804
10	10.1	10.0	2,558	88,977	100,101
12	12.1	12.0	5,160	128,050	144,060
16	16.1	16.0	9,207	228,602	257,179

4130 Steel Part #	17-4 SS Part #	Nominal Diameter mm	A Max mm	A Min mm	Grip Length mm	+/-0.25 B mm	+/-1.0 C mm	D mm	E mm	F mm	G mm	H mm
MTAAS-10-015	MTACH-10-015	10	9.96	9.92	15	11.86	9	34.8	14.2	22.1	7.4	50.8
MTAAS-10-020	MTACH-10-020	10	9.96	9.92	20	11.86	9	34.8	14.2	22.1	7.4	50.8
MTAAS-10-025	MTACH-10-025	10	9.96	9.92	25	11.86	9	34.8	14.2	22.1	7.4	50.8
MTAAS-10-030	MTACH-10-030	10	9.96	9.92	30	11.86	9	34.8	14.2	22.1	7.4	50.8
MTAAS-10-035	MTACH-10-035	10	9.96	9.92	35	11.86	9	34.8	14.2	22.1	7.4	50.8
MTAAS-10-040	MTACH-10-040	10	9.96	9.92	40	11.86	9	34.8	14.2	22.1	7.4	50.8
MTAAS-10-045	MTACH-10-045	10	9.96	9.92	45	11.86	9	34.8	14.2	22.1	7.4	50.8
MTAAS-10-050	MTACH-10-050	10	9.96	9.92	50	11.86	9	34.8	14.2	22.1	7.4	50.8
MTAAS-10-060	MTACH-10-060	10	9.96	9.92	60	11.86	9	34.8	14.2	22.1	7.4	50.8
MTAAS-10-070	MTACH-10-070	10	9.96	9.92	70	11.86	9	34.8	14.2	22.1	7.4	50.8
MTAAS-10-080	MTACH-10-080	10	9.96	9.92	80	11.86	9	34.8	14.2	22.1	7.4	50.8
MTAAS-10-090	MTACH-10-090	10	9.96	9.92	90	11.86	9	34.8	14.2	22.1	7.4	50.8
MTAAS-10-100	MTACH-10-100	10	9.96	9.92	100	11.86	9	34.8	14.2	22.1	7.4	50.8
MTAAS-12-020	MTACH-12-020	12	11.96	11.92	20	14.45	10	40.6	18.3	25.4	10.7	57.2
MTAAS-12-025	MTACH-12-025	12	11.96	11.92	25	14.45	10	40.6	18.3	25.4	10.7	57.2
MTAAS-12-030	MTACH-12-030	12	11.96	11.92	30	14.45	10	40.6	18.3	25.4	10.7	57.2
MTAAS-12-035	MTACH-12-035	12	11.96	11.92	35	14.45	10	40.6	18.3	25.4	10.7	57.2
MTAAS-12-040	MTACH-12-040	12	11.96	11.92	40	14.45	10	40.6	18.3	25.4	10.7	57.2
MTAAS-12-045	MTACH-12-045	12	11.96	11.92	45	14.45	10	40.6	18.3	25.4	10.7	57.2
MTAAS-12-050	MTACH-12-050	12	11.96	11.92	50	14.45	10	40.6	18.3	25.4	10.7	57.2
MTAAS-12-060	MTACH-12-060	12	11.96	11.92	60	14.45	10	40.6	18.3	25.4	10.7	57.2
MTAAS-12-070	MTACH-12-070	12	11.96	11.92	70	14.45	10	40.6	18.3	25.4	10.7	57.2
MTAAS-12-080	MTACH-12-080	12	11.96	11.92	80	14.45	10	40.6	18.3	25.4	10.7	57.2
MTAAS-12-090	MTACH-12-090	12	11.96	11.92	90	14.45	10	40.6	18.3	25.4	10.7	57.2
MTAAS-12-100	MTACH-12-100	12	11.96	11.92	100	14.45	10	40.6	18.3	25.4	10.7	57.2
MTAAS-16-025	MTACH-16-025	16	15.96	15.92	25	19	14	45	23.9	28.2	13.7	78
MTAAS-16-030	MTACH-16-030	16	15.96	15.92	30	19	14	45	23.9	28.2	13.7	78
MTAAS-16-035	MTACH-16-035	16	15.96	15.92	35	19	14	45	23.9	28.2	13.7	78
MTAAS-16-040	MTACH-16-040	16	15.96	15.92	40	19	14	45	23.9	28.2	13.7	78
MTAAS-16-045	MTACH-16-045	16	15.96	15.92	45	19	14	45	23.9	28.2	13.7	78
MTAAS-16-050	MTACH-16-050	16	15.96	15.92	50	19	14	45	23.9	28.2	13.7	78
MTAAS-16-060	MTACH-16-060	16	15.96	15.92	60	19	14	45	23.9	28.2	13.7	78
MTAAS-16-070	MTACH-16-070	16	15.96	15.92	70	19	14	45	23.9	28.2	13.7	78
MTAAS-16-080	MTACH-16-080	16	15.96	15.92	80	19	14	45	23.9	28.2	13.7	78
MTAAS-16-090	MTACH-16-090	16	15.96	15.92	90	19	14	45	23.9	28.2	13.7	78
MTAAS-16-100	MTACH-16-100	16	15.96	15.92	100	19	14	45	23.9	28.2	13.7	78

## QUICK RELEASE BALL LOCK PINS

### L-Handle | Inch

**MA** MODIFICATIONS AVAILABLE

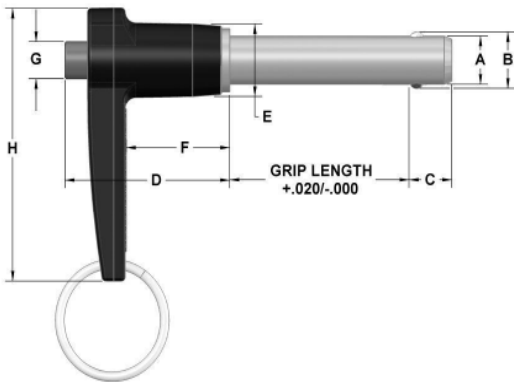

Dia	Hole Size		Min. Pull-Out Strength (lbs)	Calculated Double Shear (lbs)		
	Max	Min		4130 Steel	17-4 Stainless	300 Series SS*
3/16	.1940	.1900	200	4,600	5,150	—
1/4	.2540	.2500	230	8,200	9,200	2,200
5/16	.3165	.3125	510	12,800	14,400	3,500
3/8	.3790	.3750	575	18,400	20,600	4,500
1/2	.5050	.5000	1,160	32,800	36,800	11,500
5/8	.6300	.6250	2,070	51,200	57,500	—

\*Note: 300 Series Stainless is not recommended in applications where shear forces are a factor.

These positive locking quick release pins have a wide range of uses in fastening, locating, and alignment applications. The pins will not release until the button on the handle is depressed. Once the button is depressed, the balls retract into the shank allowing the pin to be inserted or removed into or out of a hole. They are available in three shank materials to meet your application. The handles for the pins listed below are made from 380 aluminum casting with a black finish. The pins are supplied with a stainless steel split ring for attaching a cable assembly. In addition to the standard sizes shown below, custom solutions and additional sizes are available as special order. See page 3 for complete specifications.

4130 Steel Part #	17-4 SS Part #	300 Series SS Part #	Nominal Diameter	A Max	A Min	Grip Length	+/- .005 B	+ .000/- .030 C	D	E	F	G	H
LAAS-18-050	LACH-18-050	—	3/16	.1885	.1870	.50	.220	.260	1.21	.47	.76	.23	1.84
LAAS-18-075	LACH-18-075	—	3/16	.1885	.1870	.75	.220	.260	1.21	.47	.76	.23	1.84
LAAS-18-100	LACH-18-100	—	3/16	.1885	.1870	1.00	.220	.260	1.21	.47	.76	.23	1.84
LAAS-18-125	LACH-18-125	—	3/16	.1885	.1870	1.25	.220	.260	1.21	.47	.76	.23	1.84
LAAS-18-150	LACH-18-150	—	3/16	.1885	.1870	1.50	.220	.260	1.21	.47	.76	.23	1.84
LAAS-18-175	LACH-18-175	—	3/16	.1885	.1870	1.75	.220	.260	1.21	.47	.76	.23	1.84
LAAS-18-200	LACH-18-200	—	3/16	.1885	.1870	2.00	.220	.260	1.21	.47	.76	.23	1.84
LAAS-18-250	LACH-18-250	—	3/16	.1885	.1870	2.50	.220	.260	1.21	.47	.76	.23	1.84
LAAS-18-300	LACH-18-300	—	3/16	.1885	.1870	3.00	.220	.260	1.21	.47	.76	.23	1.84
LAAS-18-350	LACH-18-350	—	3/16	.1885	.1870	3.50	.220	.260	1.21	.47	.76	.23	1.84
LAAS-18-400	LACH-18-400	—	3/16	.1885	.1870	4.00	.220	.260	1.21	.47	.76	.23	1.84
LAAS-25-050	LACH-25-050	LACS-25-050	1/4	.2485	.2470	.50	.289	.290	1.21	.47	.76	.23	1.84
LAAS-25-075	LACH-25-075	LACS-25-075	1/4	.2485	.2470	.75	.289	.290	1.21	.47	.76	.23	1.84
LAAS-25-100	LACH-25-100	LACS-25-100	1/4	.2485	.2470	1.00	.289	.290	1.21	.47	.76	.23	1.84
LAAS-25-125	LACH-25-125	LACS-25-125	1/4	.2485	.2470	1.25	.289	.290	1.21	.47	.76	.23	1.84
LAAS-25-150	LACH-25-150	LACS-25-150	1/4	.2485	.2470	1.50	.289	.290	1.21	.47	.76	.23	1.84
LAAS-25-175	LACH-25-175	LACS-25-175	1/4	.2485	.2470	1.75	.289	.290	1.21	.47	.76	.23	1.84
LAAS-25-200	LACH-25-200	LACS-25-200	1/4	.2485	.2470	2.00	.289	.290	1.21	.47	.76	.23	1.84
LAAS-25-250	LACH-25-250	LACS-25-250	1/4	.2485	.2470	2.50	.289	.290	1.21	.47	.76	.23	1.84
LAAS-25-300	LACH-25-300	LACS-25-300	1/4	.2485	.2470	3.00	.289	.290	1.21	.47	.76	.23	1.84
LAAS-25-350	LACH-25-350	LACS-25-350	1/4	.2485	.2470	3.50	.289	.290	1.21	.47	.76	.23	1.84
LAAS-25-400	LACH-25-400	LACS-25-400	1/4	.2485	.2470	4.00	.289	.290	1.21	.47	.76	.23	1.84
LAAS-31-050	LACH-31-050	LACS-31-050	5/16	.3110	.3095	.50	.375	.330	1.21	.47	.76	.23	1.84
LAAS-31-075	LACH-31-075	LACS-31-075	5/16	.3110	.3095	.75	.375	.330	1.21	.47	.76	.23	1.84
LAAS-31-100	LACH-31-100	LACS-31-100	5/16	.3110	.3095	1.00	.375	.330	1.21	.47	.76	.23	1.84
LAAS-31-125	LACH-31-125	LACS-31-125	5/16	.3110	.3095	1.25	.375	.330	1.21	.47	.76	.23	1.84
LAAS-31-150	LACH-31-150	LACS-31-150	5/16	.3110	.3095	1.50	.375	.330	1.21	.47	.76	.23	1.84
LAAS-31-175	LACH-31-175	LACS-31-175	5/16	.3110	.3095	1.75	.375	.330	1.21	.47	.76	.23	1.84
LAAS-31-200	LACH-31-200	LACS-31-200	5/16	.3110	.3095	2.00	.375	.330	1.21	.47	.76	.23	1.84
LAAS-31-250	LACH-31-250	LACS-31-250	5/16	.3110	.3095	2.50	.375	.330	1.21	.47	.76	.23	1.84
LAAS-31-300	LACH-31-300	LACS-31-300	5/16	.3110	.3095	3.00	.375	.330	1.21	.47	.76	.23	1.84
LAAS-31-350	LACH-31-350	LACS-31-350	5/16	.3110	.3095	3.50	.375	.330	1.21	.47	.76	.23	1.84
LAAS-31-400	LACH-31-400	LACS-31-400	5/16	.3110	.3095	4.00	.375	.330	1.21	.47	.76	.23	1.84

# QUICK RELEASE BALL LOCK PINS

## L-Handle | Inch (continued)

**MA** MODIFICATIONS AVAILABLE

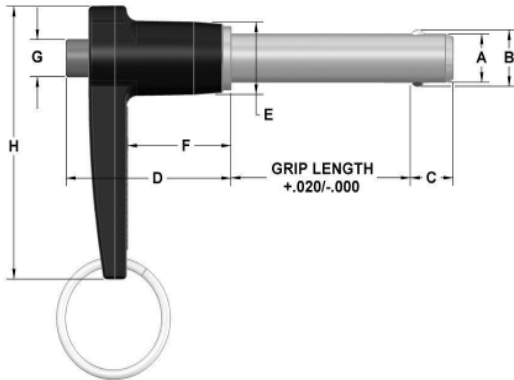

Dia	Hole Size		Min. Pull-Out Strength (lbs)	Calculated Double Shear (lbs)		
	Max	Min		4130 Steel	17-4 Stainless	300 Series SS*
3/16	.1940	.1900	200	4,600	5,150	—
1/4	.2540	.2500	230	8,200	9,200	2,200
5/16	.3165	.3125	510	12,800	14,400	3,500
3/8	.3790	.3750	575	18,400	20,600	4,500
1/2	.5050	.5000	1,160	32,800	36,800	11,500
5/8	.6300	.6250	2,070	51,200	57,500	—

\*Note: 300 Series Stainless is not recommended in applications where shear forces are a factor.

4130 Steel Part #	17-4 SS Part #	300 Series SS Part #	Nominal Diameter	A Max	A Min	Grip Length	+/-0.005 B	+0.000/-0.030 C	D	E	F	G	H
LAAS-37-050	LACH-37-050	LACS-37-050	3/8	.3735	.3720	.50	.440	.365	1.37	.56	.87	.29	2.13
LAAS-37-075	LACH-37-075	LACS-37-075	3/8	.3735	.3720	.75	.440	.365	1.37	.56	.87	.29	2.13
LAAS-37-100	LACH-37-100	LACS-37-100	3/8	.3735	.3720	1.00	.440	.365	1.37	.56	.87	.29	2.13
LAAS-37-125	LACH-37-125	LACS-37-125	3/8	.3735	.3720	1.25	.440	.365	1.37	.56	.87	.29	2.13
LAAS-37-150	LACH-37-150	LACS-37-150	3/8	.3735	.3720	1.50	.440	.365	1.37	.56	.87	.29	2.13
LAAS-37-175	LACH-37-175	LACS-37-175	3/8	.3735	.3720	1.75	.440	.365	1.37	.56	.87	.29	2.13
LAAS-37-200	LACH-37-200	LACS-37-200	3/8	.3735	.3720	2.00	.440	.365	1.37	.56	.87	.29	2.13
LAAS-37-250	LACH-37-250	LACS-37-250	3/8	.3735	.3720	2.50	.440	.365	1.37	.56	.87	.29	2.13
LAAS-37-300	LACH-37-300	LACS-37-300	3/8	.3735	.3720	3.00	.440	.365	1.37	.56	.87	.29	2.13
LAAS-37-350	LACH-37-350	LACS-37-350	3/8	.3735	.3720	3.50	.440	.365	1.37	.56	.87	.29	2.13
LAAS-37-400	LACH-37-400	LACS-37-400	3/8	.3735	.3720	4.00	.440	.365	1.37	.56	.87	.29	2.13
LAAS-50-100	LACH-50-100	LACS-50-100	1/2	.4985	.4970	1.00	.594	.460	1.60	.72	1.00	.42	2.37
LAAS-50-125	LACH-50-125	LACS-50-125	1/2	.4985	.4970	1.25	.594	.460	1.60	.72	1.00	.42	2.37
LAAS-50-150	LACH-50-150	LACS-50-150	1/2	.4985	.4970	1.50	.594	.460	1.60	.72	1.00	.42	2.37
LAAS-50-175	LACH-50-175	LACS-50-175	1/2	.4985	.4970	1.75	.594	.460	1.60	.72	1.00	.42	2.37
LAAS-50-200	LACH-50-200	LACS-50-200	1/2	.4985	.4970	2.00	.594	.460	1.60	.72	1.00	.42	2.37
LAAS-50-250	LACH-50-250	LACS-50-250	1/2	.4985	.4970	2.50	.594	.460	1.60	.72	1.00	.42	2.37
LAAS-50-300	LACH-50-300	LACS-50-300	1/2	.4985	.4970	3.00	.594	.460	1.60	.72	1.00	.42	2.37
LAAS-50-350	LACH-50-350	LACS-50-350	1/2	.4985	.4970	3.50	.594	.460	1.60	.72	1.00	.42	2.37
LAAS-50-400	LACH-50-400	LACS-50-400	1/2	.4985	.4970	4.00	.594	.460	1.60	.72	1.00	.42	2.37
LAAS-50-450	LACH-50-450	LACS-50-450	1/2	.4985	.4970	4.50	.594	.460	1.60	.72	1.00	.42	2.37
LAAS-50-500	LACH-50-500	LACS-50-500	1/2	.4985	.4970	5.00	.594	.460	1.60	.72	1.00	.42	2.37
LAAS-50-550	LACH-50-550	LACS-50-550	1/2	.4985	.4970	5.50	.594	.460	1.60	.72	1.00	.42	2.37
LAAS-50-600	LACH-50-600	LACS-50-600	1/2	.4985	.4970	6.00	.594	.460	1.60	.72	1.00	.42	2.37
LAAS-62-150	LACH-62-150	—	5/8	.6235	.6220	1.50	.750	.580	1.77	.94	1.11	.54	2.69
LAAS-62-175	LACH-62-175	—	5/8	.6235	.6220	1.75	.750	.580	1.77	.94	1.11	.54	2.69
LAAS-62-200	LACH-62-200	—	5/8	.6235	.6220	2.00	.750	.580	1.77	.94	1.11	.54	2.69
LAAS-62-250	LACH-62-250	—	5/8	.6235	.6220	2.50	.750	.580	1.77	.94	1.11	.54	2.69
LAAS-62-300	LACH-62-300	—	5/8	.6235	.6220	3.00	.750	.580	1.77	.94	1.11	.54	2.69
LAAS-62-350	LACH-62-350	—	5/8	.6235	.6220	3.50	.750	.580	1.77	.94	1.11	.54	2.69
LAAS-62-400	LACH-62-400	—	5/8	.6235	.6220	4.00	.750	.580	1.77	.94	1.11	.54	2.69
LAAS-62-450	LACH-62-450	—	5/8	.6235	.6220	4.50	.750	.580	1.77	.94	1.11	.54	2.69
LAAS-62-500	LACH-62-500	—	5/8	.6235	.6220	5.00	.750	.580	1.77	.94	1.11	.54	2.69
LAAS-62-550	LACH-62-550	—	5/8	.6235	.6220	5.50	.750	.580	1.77	.94	1.11	.54	2.69
LAAS-62-600	LACH-62-600	—	5/8	.6235	.6220	6.00	.750	.580	1.77	.94	1.11	.54	2.69

## QUICK RELEASE BALL LOCK PINS

### L-Handle | Metric

**MA** MODIFICATIONS AVAILABLE

**EXPANDED LINE**

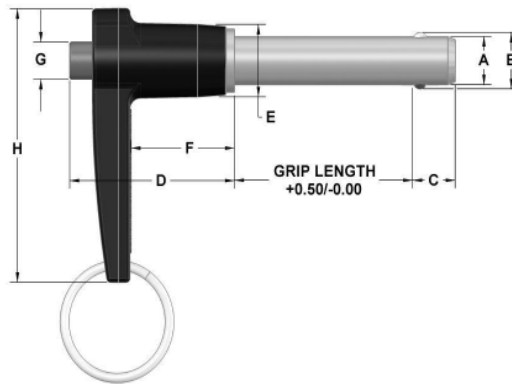

Dia mm	Hole Size mm		Min. Pull-Out Strength (N)	Calculated Double Shear (N)	
	Max	Min		4130 Steel	17-4 Stainless
5	5.1	5.0	890	21,600	24,400
6	6.1	6.0	1,023	31,686	35,640
8	8.1	8.0	2,268	56,712	63,804
10	10.1	10.0	2,558	88,977	100,101
12	12.1	12.0	5,160	128,050	144,060
16	16.1	16.0	9,207	228,602	257,179

These positive locking quick release pins have a wide range of uses in fastening, locating, and alignment applications. The pins will not release until the button on the handle is depressed. Once the button is depressed, the balls retract into the shank allowing the pin to be inserted or removed into or out of a hole. The shanks are available in 4130 steel with zinc plating or 17-4PH stainless steel. The handles for the pins listed below are made from 380 aluminum casting with a black finish. The pins are supplied with a stainless steel split ring for attaching a cable assembly. For specific application requirements, custom modifications are available for this product line. See page 3 for complete specifications. RoHS compliant.

4130 Steel Part #	17-4 SS Part #	Nominal Diameter mm	A Max mm	A Min mm	Grip Length mm	+/-0.25 B mm	+/-1.0 C mm	D mm	E mm	F mm	G mm	H mm
MLAAS-05-010	MLACH-05-010	5	4.96	4.92	10	5.54	6	30.7	11.9	19.3	5.8	46.7
MLAAS-05-015	MLACH-05-015	5	4.96	4.92	15	5.54	6	30.7	11.9	19.3	5.8	46.7
MLAAS-05-020	MLACH-05-020	5	4.96	4.92	20	5.54	6	30.7	11.9	19.3	5.8	46.7
MLAAS-05-025	MLACH-05-025	5	4.96	4.92	25	5.54	6	30.7	11.9	19.3	5.8	46.7
MLAAS-05-030	MLACH-05-030	5	4.96	4.92	30	5.54	6	30.7	11.9	19.3	5.8	46.7
MLAAS-05-035	MLACH-05-035	5	4.96	4.92	35	5.54	6	30.7	11.9	19.3	5.8	46.7
MLAAS-05-040	MLACH-05-040	5	4.96	4.92	40	5.54	6	30.7	11.9	19.3	5.8	46.7
MLAAS-05-045	MLACH-05-045	5	4.96	4.92	45	5.54	6	30.7	11.9	19.3	5.8	46.7
MLAAS-05-050	MLACH-05-050	5	4.96	4.92	50	5.54	6	30.7	11.9	19.3	5.8	46.7
MLAAS-05-060	MLACH-05-060	5	4.96	4.92	60	5.54	6	30.7	11.9	19.3	5.8	46.7
MLAAS-05-070	MLACH-05-070	5	4.96	4.92	70	5.54	6	30.7	11.9	19.3	5.8	46.7
MLAAS-05-080	MLACH-05-080	5	4.96	4.92	80	5.54	6	30.7	11.9	19.3	5.8	46.7
MLAAS-05-090	MLACH-05-090	5	4.96	4.92	90	5.54	6	30.7	11.9	19.3	5.8	46.7
MLAAS-05-100	MLACH-05-100	5	4.96	4.92	100	5.54	6	30.7	11.9	19.3	5.8	46.7
MLAAS-06-010	MLACH-06-010	6	5.96	5.92	10	6.99	7	30.7	11.9	19.3	5.8	46.7
MLAAS-06-015	MLACH-06-015	6	5.96	5.92	15	6.99	7	30.7	11.9	19.3	5.8	46.7
MLAAS-06-020	MLACH-06-020	6	5.96	5.92	20	6.99	7	30.7	11.9	19.3	5.8	46.7
MLAAS-06-025	MLACH-06-025	6	5.96	5.92	25	6.99	7	30.7	11.9	19.3	5.8	46.7
MLAAS-06-030	MLACH-06-030	6	5.96	5.92	30	6.99	7	30.7	11.9	19.3	5.8	46.7
MLAAS-06-035	MLACH-06-035	6	5.96	5.92	35	6.99	7	30.7	11.9	19.3	5.8	46.7
MLAAS-06-040	MLACH-06-040	6	5.96	5.92	40	6.99	7	30.7	11.9	19.3	5.8	46.7
MLAAS-06-045	MLACH-06-045	6	5.96	5.92	45	6.99	7	30.7	11.9	19.3	5.8	46.7
MLAAS-06-050	MLACH-06-050	6	5.96	5.92	50	6.99	7	30.7	11.9	19.3	5.8	46.7
MLAAS-06-060	MLACH-06-060	6	5.96	5.92	60	6.99	7	30.7	11.9	19.3	5.8	46.7
MLAAS-06-070	MLACH-06-070	6	5.96	5.92	70	6.99	7	30.7	11.9	19.3	5.8	46.7
MLAAS-06-080	MLACH-06-080	6	5.96	5.92	80	6.99	7	30.7	11.9	19.3	5.8	46.7
MLAAS-06-090	MLACH-06-090	6	5.96	5.92	90	6.99	7	30.7	11.9	19.3	5.8	46.7
MLAAS-06-100	MLACH-06-100	6	5.96	5.92	100	6.99	7	30.7	11.9	19.3	5.8	46.7
MLAAS-08-010	MLACH-08-010	8	7.96	7.92	10	9.42	8	30.7	11.9	19.3	5.8	46.7
MLAAS-08-015	MLACH-08-015	8	7.96	7.92	15	9.42	8	30.7	11.9	19.3	5.8	46.7
MLAAS-08-020	MLACH-08-020	8	7.96	7.92	20	9.42	8	30.7	11.9	19.3	5.8	46.7
MLAAS-08-025	MLACH-08-025	8	7.96	7.92	25	9.42	8	30.7	11.9	19.3	5.8	46.7
MLAAS-08-030	MLACH-08-030	8	7.96	7.92	30	9.42	8	30.7	11.9	19.3	5.8	46.7
MLAAS-08-035	MLACH-08-035	8	7.96	7.92	35	9.42	8	30.7	11.9	19.3	5.8	46.7
MLAAS-08-040	MLACH-08-040	8	7.96	7.92	40	9.42	8	30.7	11.9	19.3	5.8	46.7
MLAAS-08-045	MLACH-08-045	8	7.96	7.92	45	9.42	8	30.7	11.9	19.3	5.8	46.7
MLAAS-08-050	MLACH-08-050	8	7.96	7.92	50	9.42	8	30.7	11.9	19.3	5.8	46.7
MLAAS-08-060	MLACH-08-060	8	7.96	7.92	60	9.42	8	30.7	11.9	19.3	5.8	46.7
MLAAS-08-070	MLACH-08-070	8	7.96	7.92	70	9.42	8	30.7	11.9	19.3	5.8	46.7
MLAAS-08-080	MLACH-08-080	8	7.96	7.92	80	9.42	8	30.7	11.9	19.3	5.8	46.7
MLAAS-08-090	MLACH-08-090	8	7.96	7.92	90	9.42	8	30.7	11.9	19.3	5.8	46.7
MLAAS-08-100	MLACH-08-100	8	7.96	7.92	100	9.42	8	30.7	11.9	19.3	5.8	46.7

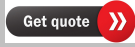

# QUICK RELEASE BALL LOCK PINS

## L-Handle | Metric (continued)

**MA** MODIFICATIONS AVAILABLE

**EXPANDED LINE**

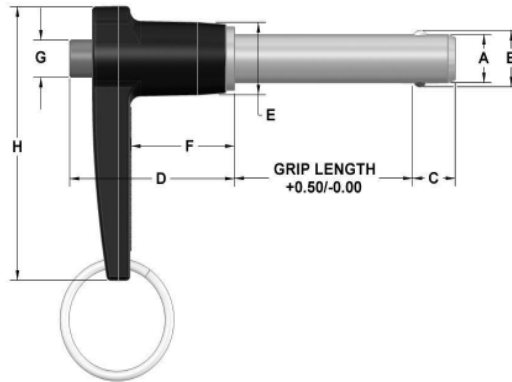

Dia mm	Hole Size mm		Min. Pull-Out Strength (N)	Calculated Double Shear (N)	
	Max	Min		4130 Steel	17-4 Stainless
5	5.1	5.0	890	21,600	24,400
6	6.1	6.0	1,023	31,686	35,640
8	8.1	8.0	2,268	56,712	63,804
10	10.1	10.0	2,558	88,977	100,101
12	12.1	12.0	5,160	128,050	144,060
16	16.1	16.0	9,207	228,602	257,179

4130 Steel Part #	17-4 SS Part #	Nominal Diameter mm	A Max mm	A Min mm	Grip Length mm	+/-0.25 B mm	+/-1.0 C mm	D mm	E mm	F mm	G mm	H mm
MLAAS-10-015	MLACH-10-015	10	9.96	9.92	15	11.86	9	34.8	14.2	22.1	7.4	54.1
MLAAS-10-020	MLACH-10-020	10	9.96	9.92	20	11.86	9	34.8	14.2	22.1	7.4	54.1
MLAAS-10-025	MLACH-10-025	10	9.96	9.92	25	11.86	9	34.8	14.2	22.1	7.4	54.1
MLAAS-10-030	MLACH-10-030	10	9.96	9.92	30	11.86	9	34.8	14.2	22.1	7.4	54.1
MLAAS-10-035	MLACH-10-035	10	9.96	9.92	35	11.86	9	34.8	14.2	22.1	7.4	54.1
MLAAS-10-040	MLACH-10-040	10	9.96	9.92	40	11.86	9	34.8	14.2	22.1	7.4	54.1
MLAAS-10-045	MLACH-10-045	10	9.96	9.92	45	11.86	9	34.8	14.2	22.1	7.4	54.1
MLAAS-10-050	MLACH-10-050	10	9.96	9.92	50	11.86	9	34.8	14.2	22.1	7.4	54.1
MLAAS-10-060	MLACH-10-060	10	9.96	9.92	60	11.86	9	34.8	14.2	22.1	7.4	54.1
MLAAS-10-070	MLACH-10-070	10	9.96	9.92	70	11.86	9	34.8	14.2	22.1	7.4	54.1
MLAAS-10-080	MLACH-10-080	10	9.96	9.92	80	11.86	9	34.8	14.2	22.1	7.4	54.1
MLAAS-10-090	MLACH-10-090	10	9.96	9.92	90	11.86	9	34.8	14.2	22.1	7.4	54.1
MLAAS-10-100	MLACH-10-100	10	9.96	9.92	100	11.86	9	34.8	14.2	22.1	7.4	54.1
MLAAS-12-020	MLACH-12-020	12	11.96	11.92	20	14.45	10	40.6	18.3	25.4	10.7	60.2
MLAAS-12-025	MLACH-12-025	12	11.96	11.92	25	14.45	10	40.6	18.3	25.4	10.7	60.2
MLAAS-12-030	MLACH-12-030	12	11.96	11.92	30	14.45	10	40.6	18.3	25.4	10.7	60.2
MLAAS-12-035	MLACH-12-035	12	11.96	11.92	35	14.45	10	40.6	18.3	25.4	10.7	60.2
MLAAS-12-040	MLACH-12-040	12	11.96	11.92	40	14.45	10	40.6	18.3	25.4	10.7	60.2
MLAAS-12-045	MLACH-12-045	12	11.96	11.92	45	14.45	10	40.6	18.3	25.4	10.7	60.2
MLAAS-12-050	MLACH-12-050	12	11.96	11.92	50	14.45	10	40.6	18.3	25.4	10.7	60.2
MLAAS-12-060	MLACH-12-060	12	11.96	11.92	60	14.45	10	40.6	18.3	25.4	10.7	60.2
MLAAS-12-070	MLACH-12-070	12	11.96	11.92	70	14.45	10	40.6	18.3	25.4	10.7	60.2
MLAAS-12-080	MLACH-12-080	12	11.96	11.92	80	14.45	10	40.6	18.3	25.4	10.7	60.2
MLAAS-12-090	MLACH-12-090	12	11.96	11.92	90	14.45	10	40.6	18.3	25.4	10.7	60.2
MLAAS-12-100	MLACH-12-100	12	11.96	11.92	100	14.45	10	40.6	18.3	25.4	10.7	60.2
MLAAS-16-025	MLACH-16-025	16	15.96	15.92	25	19	14	45	23.9	28.2	13.7	68.3
MLAAS-16-030	MLACH-16-030	16	15.96	15.92	30	19	14	45	23.9	28.2	13.7	68.3
MLAAS-16-035	MLACH-16-035	16	15.96	15.92	35	19	14	45	23.9	28.2	13.7	68.3
MLAAS-16-040	MLACH-16-040	16	15.96	15.92	40	19	14	45	23.9	28.2	13.7	68.3
MLAAS-16-045	MLACH-16-045	16	15.96	15.92	45	19	14	45	23.9	28.2	13.7	68.3
MLAAS-16-050	MLACH-16-050	16	15.96	15.92	50	19	14	45	23.9	28.2	13.7	68.3
MLAAS-16-060	MLACH-16-060	16	15.96	15.92	60	19	14	45	23.9	28.2	13.7	68.3
MLAAS-16-070	MLACH-16-070	16	15.96	15.92	70	19	14	45	23.9	28.2	13.7	68.3
MLAAS-16-080	MLACH-16-080	16	15.96	15.92	80	19	14	45	23.9	28.2	13.7	68.3
MLAAS-16-090	MLACH-16-090	16	15.96	15.92	90	19	14	45	23.9	28.2	13.7	68.3
MLAAS-16-100	MLACH-16-100	16	15.96	15.92	100	19	14	45	23.9	28.2	13.7	68.3

# QUICK RELEASE BALL LOCK PINS

## Aluminum Button Handle | Inch

**MA** MODIFICATIONS AVAILABLE

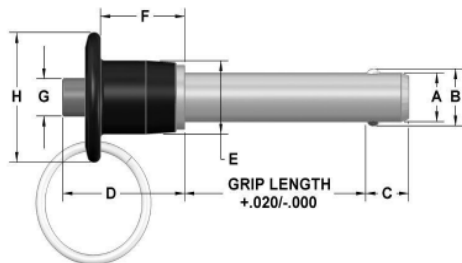

Dia	Hole Size		Min. Pull-Out Strength (lbs)	Calculated Double Shear (lbs)		
	Max	Min		4130 Steel	17-4 Stainless	300 Series SS*
3/16	.1940	.1900	200	4,600	5,150	—
1/4	.2540	.2500	230	8,200	9,200	2,200
5/16	.3165	.3125	510	12,800	14,400	3,500
3/8	.3790	.3750	575	18,400	20,600	4,500
1/2	.5050	.5000	1,160	32,800	36,800	11,500
5/8	.6300	.6250	2,070	51,200	57,500	—

\*Note: 300 Series Stainless is not recommended in applications where shear forces are a factor.

These positive locking quick release pins have a wide range of uses in fastening, locating, and alignment applications. The pins will not release until the button on the handle is depressed. Once the button is depressed, the balls retract into the shank allowing the pin to be inserted or removed into or out of a hole. They are available in three shank materials to meet your application. The handles for the pins listed below are made from 2024-T4 aluminum and anodized black. The pins are supplied with a stainless steel split ring for attaching a cable assembly. In addition to the standard sizes shown below, custom solutions and additional sizes are available as special order. See page 3 for complete specifications.

4130 Steel Part #	17-4 SS Part #	300 Series SS Part #	Nominal Diameter	A Max	A Min	Grip Length	+/-005 B	+000/-030 C	D	E	F	G	H
BAAS-18-050	BACH-18-050	—	3/16	.1885	.1870	.50	.220	.260	.92	.47	.63	.23	.81
BAAS-18-075	BACH-18-075	—	3/16	.1885	.1870	.75	.220	.260	.92	.47	.63	.23	.81
BAAS-18-100	BACH-18-100	—	3/16	.1885	.1870	1.00	.220	.260	.92	.47	.63	.23	.81
BAAS-18-125	BACH-18-125	—	3/16	.1885	.1870	1.25	.220	.260	.92	.47	.63	.23	.81
BAAS-18-150	BACH-18-150	—	3/16	.1885	.1870	1.50	.220	.260	.92	.47	.63	.23	.81
BAAS-18-175	BACH-18-175	—	3/16	.1885	.1870	1.75	.220	.260	.92	.47	.63	.23	.81
BAAS-18-200	BACH-18-200	—	3/16	.1885	.1870	2.00	.220	.260	.92	.47	.63	.23	.81
BAAS-18-250	BACH-18-250	—	3/16	.1885	.1870	2.50	.220	.260	.92	.47	.63	.23	.81
BAAS-18-300	BACH-18-300	—	3/16	.1885	.1870	3.00	.220	.260	.92	.47	.63	.23	.81
BAAS-18-350	BACH-18-350	—	3/16	.1885	.1870	3.50	.220	.260	.92	.47	.63	.23	.81
BAAS-18-400	BACH-18-400	—	3/16	.1885	.1870	4.00	.220	.260	.92	.47	.63	.23	.81
BAAS-25-050	BACH-25-050	BACS-25-050	1/4	.2485	.2470	.50	.289	.290	.92	.47	.63	.23	.81
BAAS-25-075	BACH-25-075	BACS-25-075	1/4	.2485	.2470	.75	.289	.290	.92	.47	.63	.23	.81
BAAS-25-100	BACH-25-100	BACS-25-100	1/4	.2485	.2470	1.00	.289	.290	.92	.47	.63	.23	.81
BAAS-25-125	BACH-25-125	BACS-25-125	1/4	.2485	.2470	1.25	.289	.290	.92	.47	.63	.23	.81
BAAS-25-150	BACH-25-150	BACS-25-150	1/4	.2485	.2470	1.50	.289	.290	.92	.47	.63	.23	.81
BAAS-25-175	BACH-25-175	BACS-25-175	1/4	.2485	.2470	1.75	.289	.290	.92	.47	.63	.23	.81
BAAS-25-200	BACH-25-200	BACS-25-200	1/4	.2485	.2470	2.00	.289	.290	.92	.47	.63	.23	.81
BAAS-25-250	BACH-25-250	BACS-25-250	1/4	.2485	.2470	2.50	.289	.290	.92	.47	.63	.23	.81
BAAS-25-300	BACH-25-300	BACS-25-300	1/4	.2485	.2470	3.00	.289	.290	.92	.47	.63	.23	.81
BAAS-25-350	BACH-25-350	BACS-25-350	1/4	.2485	.2470	3.50	.289	.290	.92	.47	.63	.23	.81
BAAS-25-400	BACH-25-400	BACS-25-400	1/4	.2485	.2470	4.00	.289	.290	.92	.47	.63	.23	.81
BAAS-31-050	BACH-31-050	BACS-31-050	5/16	.3110	.3095	.50	.375	.330	.92	.47	.63	.23	.81
BAAS-31-075	BACH-31-075	BACS-31-075	5/16	.3110	.3095	.75	.375	.330	.92	.47	.63	.23	.81
BAAS-31-100	BACH-31-100	BACS-31-100	5/16	.3110	.3095	1.00	.375	.330	.92	.47	.63	.23	.81
BAAS-31-125	BACH-31-125	BACS-31-125	5/16	.3110	.3095	1.25	.375	.330	.92	.47	.63	.23	.81
BAAS-31-150	BACH-31-150	BACS-31-150	5/16	.3110	.3095	1.50	.375	.330	.92	.47	.63	.23	.81
BAAS-31-175	BACH-31-175	BACS-31-175	5/16	.3110	.3095	1.75	.375	.330	.92	.47	.63	.23	.81
BAAS-31-200	BACH-31-200	BACS-31-200	5/16	.3110	.3095	2.00	.375	.330	.92	.47	.63	.23	.81
BAAS-31-250	BACH-31-250	BACS-31-250	5/16	.3110	.3095	2.50	.375	.330	.92	.47	.63	.23	.81
BAAS-31-300	BACH-31-300	BACS-31-300	5/16	.3110	.3095	3.00	.375	.330	.92	.47	.63	.23	.81
BAAS-31-350	BACH-31-350	BACS-31-350	5/16	.3110	.3095	3.50	.375	.330	.92	.47	.63	.23	.81
BAAS-31-400	BACH-31-400	BACS-31-400	5/16	.3110	.3095	4.00	.375	.330	.92	.47	.63	.23	.81



## QUICK RELEASE BALL LOCK PINS

### Aluminum Button Handle 1 Inch (continued)

**MA** MODIFICATIONS AVAILABLE

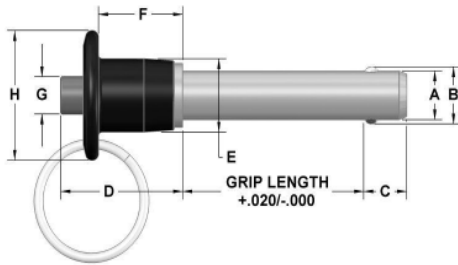

Dia	Hole Size		Min. Pull-Out Strength (lbs)	Calculated Double Shear (lbs)		
	Max	Min		4130 Steel	17-4 Stainless	300 Series SS*
3/16	.1940	.1900	200	4,600	5,150	—
1/4	.2540	.2500	230	8,200	9,200	2,200
5/16	.3165	.3125	510	12,800	14,400	3,500
3/8	.3790	.3750	575	18,400	20,600	4,500
1/2	.5050	.5000	1,160	32,800	36,800	11,500
5/8	.6300	.6250	2,070	51,200	57,500	—

\*Note: 300 Series Stainless is not recommended in applications where shear forces are a factor.

4130 Steel Part #	17-4 SS Part #	300 Series SS Part #	Nominal Diameter	A Max	A Min	Grip Length	+/- .005 B	+ .000/- .030 C	D	E	F	G	H
BAAS-37-050	BACH-37-050	BACS-37-050	3/8	.3735	.3720	.50	.440	.365	1.01	.56	.70	.29	1.00
BAAS-37-075	BACH-37-075	BACS-37-075	3/8	.3735	.3720	.75	.440	.365	1.01	.56	.70	.29	1.00
BAAS-37-100	BACH-37-100	BACS-37-100	3/8	.3735	.3720	1.00	.440	.365	1.01	.56	.70	.29	1.00
BAAS-37-125	BACH-37-125	BACS-37-125	3/8	.3735	.3720	1.25	.440	.365	1.01	.56	.70	.29	1.00
BAAS-37-150	BACH-37-150	BACS-37-150	3/8	.3735	.3720	1.50	.440	.365	1.01	.56	.70	.29	1.00
BAAS-37-175	BACH-37-175	BACS-37-175	3/8	.3735	.3720	1.75	.440	.365	1.01	.56	.70	.29	1.00
BAAS-37-200	BACH-37-200	BACS-37-200	3/8	.3735	.3720	2.00	.440	.365	1.01	.56	.70	.29	1.00
BAAS-37-250	BACH-37-250	BACS-37-250	3/8	.3735	.3720	2.50	.440	.365	1.01	.56	.70	.29	1.00
BAAS-37-300	BACH-37-300	BACS-37-300	3/8	.3735	.3720	3.00	.440	.365	1.01	.56	.70	.29	1.00
BAAS-37-350	BACH-37-350	BACS-37-350	3/8	.3735	.3720	3.50	.440	.365	1.01	.56	.70	.29	1.00
BAAS-37-400	BACH-37-400	BACS-37-400	3/8	.3735	.3720	4.00	.440	.365	1.01	.56	.70	.29	1.00
BAAS-50-100	BACH-50-100	BACS-50-100	1/2	.4985	.4970	1.00	.594	.460	1.27	.72	.85	.42	1.37
BAAS-50-125	BACH-50-125	BACS-50-125	1/2	.4985	.4970	1.25	.594	.460	1.27	.72	.85	.42	1.37
BAAS-50-150	BACH-50-150	BACS-50-150	1/2	.4985	.4970	1.50	.594	.460	1.27	.72	.85	.42	1.37
BAAS-50-175	BACH-50-175	BACS-50-175	1/2	.4985	.4970	1.75	.594	.460	1.27	.72	.85	.42	1.37
BAAS-50-200	BACH-50-200	BACS-50-200	1/2	.4985	.4970	2.00	.594	.460	1.27	.72	.85	.42	1.37
BAAS-50-250	BACH-50-250	BACS-50-250	1/2	.4985	.4970	2.50	.594	.460	1.27	.72	.85	.42	1.37
BAAS-50-300	BACH-50-300	BACS-50-300	1/2	.4985	.4970	3.00	.594	.460	1.27	.72	.85	.42	1.37
BAAS-50-350	BACH-50-350	BACS-50-350	1/2	.4985	.4970	3.50	.594	.460	1.27	.72	.85	.42	1.37
BAAS-50-400	BACH-50-400	BACS-50-400	1/2	.4985	.4970	4.00	.594	.460	1.27	.72	.85	.42	1.37
BAAS-50-450	BACH-50-450	BACS-50-450	1/2	.4985	.4970	4.50	.594	.460	1.27	.72	.85	.42	1.37
BAAS-50-500	BACH-50-500	BACS-50-500	1/2	.4985	.4970	5.00	.594	.460	1.27	.72	.85	.42	1.37
BAAS-50-550	BACH-50-550	BACS-50-550	1/2	.4985	.4970	5.50	.594	.460	1.27	.72	.85	.42	1.37
BAAS-50-600	BACH-50-600	BACS-50-600	1/2	.4985	.4970	6.00	.594	.460	1.27	.72	.85	.42	1.37
BAAS-62-150	BACH-62-150	—	5/8	.6235	.6220	1.50	.750	.580	1.65	.94	1.10	.54	1.75
BAAS-62-175	BACH-62-175	—	5/8	.6235	.6220	1.75	.750	.580	1.65	.94	1.10	.54	1.75
BAAS-62-200	BACH-62-200	—	5/8	.6235	.6220	2.00	.750	.580	1.65	.94	1.10	.54	1.75
BAAS-62-250	BACH-62-250	—	5/8	.6235	.6220	2.50	.750	.580	1.65	.94	1.10	.54	1.75
BAAS-62-300	BACH-62-300	—	5/8	.6235	.6220	3.00	.750	.580	1.65	.94	1.10	.54	1.75
BAAS-62-350	BACH-62-350	—	5/8	.6235	.6220	3.50	.750	.580	1.65	.94	1.10	.54	1.75
BAAS-62-400	BACH-62-400	—	5/8	.6235	.6220	4.00	.750	.580	1.65	.94	1.10	.54	1.75
BAAS-62-450	BACH-62-450	—	5/8	.6235	.6220	4.50	.750	.580	1.65	.94	1.10	.54	1.75
BAAS-62-500	BACH-62-500	—	5/8	.6235	.6220	5.00	.750	.580	1.65	.94	1.10	.54	1.75
BAAS-62-550	BACH-62-550	—	5/8	.6235	.6220	5.50	.750	.580	1.65	.94	1.10	.54	1.75
BAAS-62-600	BACH-62-600	—	5/8	.6235	.6220	6.00	.750	.580	1.65	.94	1.10	.54	1.75

## QUICK RELEASE BALL LOCK PINS

### Aluminum Button Handle | Metric

**MA** MODIFICATIONS AVAILABLE

**EXPANDED LINE**

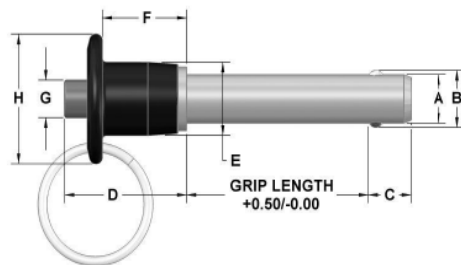

Dia mm	Hole Size mm		Min. Pull-Out Strength (N)	Calculated Double Shear (N)	
	Max	Min		4130 Steel	17-4 Stainless
5	5.1	5.0	890	21,600	24,400
6	6.1	6.0	1,023	31,686	35,640
8	8.1	8.0	2,268	56,712	63,804
10	10.1	10.0	2,558	88,977	100,101
12	12.1	12.0	5,160	128,050	144,060
16	16.1	16.0	9,207	228,602	257,179

These positive locking quick release pins have a wide range of uses in fastening, locating, and alignment applications. The pins will not release until the button on the handle is depressed. Once the button is depressed, the balls retract into the shank allowing the pin to be inserted or removed into or out of a hole. The shanks are available in 4130 steel with zinc plating or 17-4PH stainless steel. The handles for the pins listed below are made from 2024-T4 aluminum and anodized black. Stainless handles are also available. The pins are supplied with a stainless steel split ring for attaching a cable assembly. For specific application requirements, custom modifications are available for this product line. See page 3 for complete specifications. RoHS compliant.

4130 Steel Part #	17-4SS Part #	Nominal Diameter mm	A Max mm	A Min mm	Grip Length mm	+/-0.25 B mm	+/-1.0 C mm	D mm	E mm	F mm	G mm	H mm
MBAAS-05-010	MBACH-05-010	5	4.96	4.92	10	5.54	6	23.4	11.9	16	5.8	20.6
MBAAS-05-015	MBACH-05-015	5	4.96	4.92	15	5.54	6	23.4	11.9	16	5.8	20.6
MBAAS-05-020	MBACH-05-020	5	4.96	4.92	20	5.54	6	23.4	11.9	16	5.8	20.6
MBAAS-05-025	MBACH-05-025	5	4.96	4.92	25	5.54	6	23.4	11.9	16	5.8	20.6
MBAAS-05-030	MBACH-05-030	5	4.96	4.92	30	5.54	6	23.4	11.9	16	5.8	20.6
MBAAS-05-035	MBACH-05-035	5	4.96	4.92	35	5.54	6	23.4	11.9	16	5.8	20.6
MBAAS-05-040	MBACH-05-040	5	4.96	4.92	40	5.54	6	23.4	11.9	16	5.8	20.6
MBAAS-05-045	MBACH-05-045	5	4.96	4.92	45	5.54	6	23.4	11.9	16	5.8	20.6
MBAAS-05-050	MBACH-05-050	5	4.96	4.92	50	5.54	6	23.4	11.9	16	5.8	20.6
MBAAS-05-060	MBACH-05-060	5	4.96	4.92	60	5.54	6	23.4	11.9	16	5.8	20.6
MBAAS-05-070	MBACH-05-070	5	4.96	4.92	70	5.54	6	23.4	11.9	16	5.8	20.6
MBAAS-05-080	MBACH-05-080	5	4.96	4.92	80	5.54	6	23.4	11.9	16	5.8	20.6
MBAAS-05-090	MBACH-05-090	5	4.96	4.92	90	5.54	6	23.4	11.9	16	5.8	20.6
MBAAS-05-100	MBACH-05-100	5	4.96	4.92	100	5.54	6	23.4	11.9	16	5.8	20.6
MBAAS-06-010	MBACH-06-010	6	5.96	5.92	10	6.99	7	23.4	11.9	16	5.8	20.6
MBAAS-06-015	MBACH-06-015	6	5.96	5.92	15	6.99	7	23.4	11.9	16	5.8	20.6
MBAAS-06-020	MBACH-06-020	6	5.96	5.92	20	6.99	7	23.4	11.9	16	5.8	20.6
MBAAS-06-025	MBACH-06-025	6	5.96	5.92	25	6.99	7	23.4	11.9	16	5.8	20.6
MBAAS-06-030	MBACH-06-030	6	5.96	5.92	30	6.99	7	23.4	11.9	16	5.8	20.6
MBAAS-06-035	MBACH-06-035	6	5.96	5.92	35	6.99	7	23.4	11.9	16	5.8	20.6
MBAAS-06-040	MBACH-06-040	6	5.96	5.92	40	6.99	7	23.4	11.9	16	5.8	20.6
MBAAS-06-045	MBACH-06-045	6	5.96	5.92	45	6.99	7	23.4	11.9	16	5.8	20.6
MBAAS-06-050	MBACH-06-050	6	5.96	5.92	50	6.99	7	23.4	11.9	16	5.8	20.6
MBAAS-06-060	MBACH-06-060	6	5.96	5.92	60	6.99	7	23.4	11.9	16	5.8	20.6
MBAAS-06-070	MBACH-06-070	6	5.96	5.92	70	6.99	7	23.4	11.9	16	5.8	20.6
MBAAS-06-080	MBACH-06-080	6	5.96	5.92	80	6.99	7	23.4	11.9	16	5.8	20.6
MBAAS-06-090	MBACH-06-090	6	5.96	5.92	90	6.99	7	23.4	11.9	16	5.8	20.6
MBAAS-06-100	MBACH-06-100	6	5.96	5.92	100	6.99	7	23.4	11.9	16	5.8	20.6
MBAAS-08-010	MBACH-08-010	8	7.96	7.92	10	9.42	8	23.4	11.9	16	5.8	20.6
MBAAS-08-015	MBACH-08-015	8	7.96	7.92	15	9.42	8	23.4	11.9	16	5.8	20.6
MBAAS-08-020	MBACH-08-020	8	7.96	7.92	20	9.42	8	23.4	11.9	16	5.8	20.6
MBAAS-08-025	MBACH-08-025	8	7.96	7.92	25	9.42	8	23.4	11.9	16	5.8	20.6
MBAAS-08-030	MBACH-08-030	8	7.96	7.92	30	9.42	8	23.4	11.9	16	5.8	20.6
MBAAS-08-035	MBACH-08-035	8	7.96	7.92	35	9.42	8	23.4	11.9	16	5.8	20.6
MBAAS-08-040	MBACH-08-040	8	7.96	7.92	40	9.42	8	23.4	11.9	16	5.8	20.6
MBAAS-08-045	MBACH-08-045	8	7.96	7.92	45	9.42	8	23.4	11.9	16	5.8	20.6
MBAAS-08-050	MBACH-08-050	8	7.96	7.92	50	9.42	8	23.4	11.9	16	5.8	20.6
MBAAS-08-060	MBACH-08-060	8	7.96	7.92	60	9.42	8	23.4	11.9	16	5.8	20.6
MBAAS-08-070	MBACH-08-070	8	7.96	7.92	70	9.42	8	23.4	11.9	16	5.8	20.6
MBAAS-08-080	MBACH-08-080	8	7.96	7.92	80	9.42	8	23.4	11.9	16	5.8	20.6
MBAAS-08-090	MBACH-08-090	8	7.96	7.92	90	9.42	8	23.4	11.9	16	5.8	20.6
MBAAS-08-100	MBACH-08-100	8	7.96	7.92	100	9.42	8	23.4	11.9	16	5.8	20.6



## QUICK RELEASE BALL LOCK PINS

### Aluminum Button Handle | Metric (continued)

**MA** MODIFICATIONS AVAILABLE

**EXPANDED LINE**

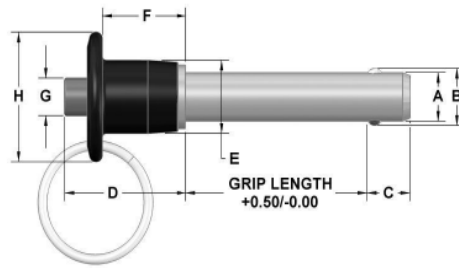

Dia mm	Hole Size		Min. Pull-Out Strength (N)	Calculated Double Shear (N)	
	Max mm	Min mm		4130 Steel	17-4 Stainless
5	5.1	5.0	890	21,600	24,400
6	6.1	6.0	1,023	31,686	35,640
8	8.1	8.0	2,268	56,712	63,804
10	10.1	10.0	2,558	88,977	100,101
12	12.1	12.0	5,160	128,050	144,060
16	16.1	16.0	9,207	228,602	257,179

4130 Steel Part#	17-4 SS Part#	Nominal Diameter mm	A Max mm	A Min mm	Grip Length mm	+/-0.25 B mm	+/-1.0 C mm	D mm	E mm	F mm	G mm	H mm
MBAAS-10-015	MBACH-10-015	10	9.96	9.92	15	11.86	9	25.7	14.2	17.8	7.4	25.4
MBAAS-10-020	MBACH-10-020	10	9.96	9.92	20	11.86	9	25.7	14.2	17.8	7.4	25.4
MBAAS-10-025	MBACH-10-025	10	9.96	9.92	25	11.86	9	25.7	14.2	17.8	7.4	25.4
MBAAS-10-030	MBACH-10-030	10	9.96	9.92	30	11.86	9	25.7	14.2	17.8	7.4	25.4
MBAAS-10-035	MBACH-10-035	10	9.96	9.92	35	11.86	9	25.7	14.2	17.8	7.4	25.4
MBAAS-10-040	MBACH-10-040	10	9.96	9.92	40	11.86	9	25.7	14.2	17.8	7.4	25.4
MBAAS-10-045	MBACH-10-045	10	9.96	9.92	45	11.86	9	25.7	14.2	17.8	7.4	25.4
MBAAS-10-050	MBACH-10-050	10	9.96	9.92	50	11.86	9	25.7	14.2	17.8	7.4	25.4
MBAAS-10-060	MBACH-10-060	10	9.96	9.92	60	11.86	9	25.7	14.2	17.8	7.4	25.4
MBAAS-10-070	MBACH-10-070	10	9.96	9.92	70	11.86	9	25.7	14.2	17.8	7.4	25.4
MBAAS-10-080	MBACH-10-080	10	9.96	9.92	80	11.86	9	25.7	14.2	17.8	7.4	25.4
MBAAS-10-090	MBACH-10-090	10	9.96	9.92	90	11.86	9	25.7	14.2	17.8	7.4	25.4
MBAAS-10-100	MBACH-10-100	10	9.96	9.92	100	11.86	9	25.7	14.2	17.8	7.4	25.4
MBAAS-12-020	MBACH-12-020	12	11.96	11.92	20	14.45	10	32.3	18.3	21.6	10.7	34.7
MBAAS-12-025	MBACH-12-025	12	11.96	11.92	25	14.45	10	32.3	18.3	21.6	10.7	34.7
MBAAS-12-030	MBACH-12-030	12	11.96	11.92	30	14.45	10	32.3	18.3	21.6	10.7	34.7
MBAAS-12-035	MBACH-12-035	12	11.96	11.92	35	14.45	10	32.3	18.3	21.6	10.7	34.7
MBAAS-12-040	MBACH-12-040	12	11.96	11.92	40	14.45	10	32.3	18.3	21.6	10.7	34.7
MBAAS-12-045	MBACH-12-045	12	11.96	11.92	45	14.45	10	32.3	18.3	21.6	10.7	34.7
MBAAS-12-050	MBACH-12-050	12	11.96	11.92	50	14.45	10	32.3	18.3	21.6	10.7	34.7
MBAAS-12-060	MBACH-12-060	12	11.96	11.92	60	14.45	10	32.3	18.3	21.6	10.7	34.7
MBAAS-12-070	MBACH-12-070	12	11.96	11.92	70	14.45	10	32.3	18.3	21.6	10.7	34.7
MBAAS-12-080	MBACH-12-080	12	11.96	11.92	80	14.45	10	32.3	18.3	21.6	10.7	34.7
MBAAS-12-090	MBACH-12-090	12	11.96	11.92	90	14.45	10	32.3	18.3	21.6	10.7	34.7
MBAAS-12-100	MBACH-12-100	12	11.96	11.92	100	14.45	10	32.3	18.3	21.6	10.7	34.7
MBAAS-16-025	MBACH-16-025	16	15.96	15.92	25	19	14	41.9	23.9	27.9	13.7	44.5
MBAAS-16-030	MBACH-16-030	16	15.96	15.92	30	19	14	41.9	23.9	27.9	13.7	44.5
MBAAS-16-035	MBACH-16-035	16	15.96	15.92	35	19	14	41.9	23.9	27.9	13.7	44.5
MBAAS-16-040	MBACH-16-040	16	15.96	15.92	40	19	14	41.9	23.9	27.9	13.7	44.5
MBAAS-16-045	MBACH-16-045	16	15.96	15.92	45	19	14	41.9	23.9	27.9	13.7	44.5
MBAAS-16-050	MBACH-16-050	16	15.96	15.92	50	19	14	41.9	23.9	27.9	13.7	44.5
MBAAS-16-060	MBACH-16-060	16	15.96	15.92	60	19	14	41.9	23.9	27.9	13.7	44.5
MBAAS-16-070	MBACH-16-070	16	15.96	15.92	70	19	14	41.9	23.9	27.9	13.7	44.5
MBAAS-16-080	MBACH-16-080	16	15.96	15.92	80	19	14	41.9	23.9	27.9	13.7	44.5
MBAAS-16-090	MBACH-16-090	16	15.96	15.92	90	19	14	41.9	23.9	27.9	13.7	44.5
MBAAS-16-100	MBACH-16-100	16	15.96	15.92	100	19	14	41.9	23.9	27.9	13.7	44.5

# QUICK RELEASE BALL LOCK PINS

## Stainless Steel Button Handle | Inch

**MA** MODIFICATIONS AVAILABLE

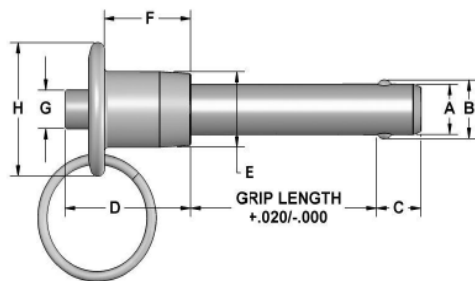

Dia	Hole Size		Min. Pull-Out Strength (lbs)	Calculated Double Shear (lbs)	
	Max	Min		17-4 Stainless	300 Series SS*
3/16	.1940	.1900	200	5,150	—
1/4	.2540	.2500	230	9,200	2,200
5/16	.3165	.3125	510	14,400	3,500
3/8	.3790	.3750	575	20,600	4,500
1/2	.5050	.5000	1,160	36,800	11,500

\*Note: 300 Series Stainless is not recommended in applications where shear forces are a factor.

These positive locking quick release pins have a wide range of uses in fastening, locating, and alignment applications. The pins will not release until the button on the handle is depressed. Once the button is depressed, the balls retract into the shank allowing the pin to be inserted or removed into or out of a hole. They are available in two types of stainless steel to meet your application. The handles and actuator buttons for the pins listed below are made from 303 stainless steel. The pins are supplied with a stainless steel split ring for attaching a cable assembly. For specific application requirements, custom modifications are available for this product line. See page 3 for complete specifications.

17-4 SS Part#	300 Series SS Part#	Nominal Diameter	A Max	A Min	Grip Length	+/- .005 B	+ .000/- .030 C	D	E	F	G	H
BCCH-18-050	—	3/16	.1885	.1870	.50	.220	.260	.92	.47	.63	.23	.81
BCCH-18-075	—	3/16	.1885	.1870	.75	.220	.260	.92	.47	.63	.23	.81
BCCH-18-100	—	3/16	.1885	.1870	1.00	.220	.260	.92	.47	.63	.23	.81
BCCH-18-125	—	3/16	.1885	.1870	1.25	.220	.260	.92	.47	.63	.23	.81
BCCH-18-150	—	3/16	.1885	.1870	1.50	.220	.260	.92	.47	.63	.23	.81
BCCH-18-175	—	3/16	.1885	.1870	1.75	.220	.260	.92	.47	.63	.23	.81
BCCH-18-200	—	3/16	.1885	.1870	2.00	.220	.260	.92	.47	.63	.23	.81
BCCH-18-250	—	3/16	.1885	.1870	2.50	.220	.260	.92	.47	.63	.23	.81
BCCH-18-300	—	3/16	.1885	.1870	3.00	.220	.260	.92	.47	.63	.23	.81
BCCH-18-350	—	3/16	.1885	.1870	3.50	.220	.260	.92	.47	.63	.23	.81
BCCH-18-400	—	3/16	.1885	.1870	4.00	.220	.260	.92	.47	.63	.23	.81
BCCH-25-050	BCCS-25-050	1/4	.2485	.2470	.50	.289	.290	.92	.47	.63	.23	.81
BCCH-25-075	BCCS-25-075	1/4	.2485	.2470	.75	.289	.290	.92	.47	.63	.23	.81
BCCH-25-100	BCCS-25-100	1/4	.2485	.2470	1.00	.289	.290	.92	.47	.63	.23	.81
BCCH-25-125	BCCS-25-125	1/4	.2485	.2470	1.25	.289	.290	.92	.47	.63	.23	.81
BCCH-25-150	BCCS-25-150	1/4	.2485	.2470	1.50	.289	.290	.92	.47	.63	.23	.81
BCCH-25-175	BCCS-25-175	1/4	.2485	.2470	1.75	.289	.290	.92	.47	.63	.23	.81
BCCH-25-200	BCCS-25-200	1/4	.2485	.2470	2.00	.289	.290	.92	.47	.63	.23	.81
BCCH-25-250	BCCS-25-250	1/4	.2485	.2470	2.50	.289	.290	.92	.47	.63	.23	.81
BCCH-25-300	BCCS-25-300	1/4	.2485	.2470	3.00	.289	.290	.92	.47	.63	.23	.81
BCCH-25-350	BCCS-25-350	1/4	.2485	.2470	3.50	.289	.290	.92	.47	.63	.23	.81
BCCH-25-400	BCCS-25-400	1/4	.2485	.2470	4.00	.289	.290	.92	.47	.63	.23	.81
BCCH-31-050	BCCS-31-050	5/16	.3110	.3095	.50	.375	.330	.92	.47	.63	.23	.81
BCCH-31-075	BCCS-31-075	5/16	.3110	.3095	.75	.375	.330	.92	.47	.63	.23	.81
BCCH-31-100	BCCS-31-100	5/16	.3110	.3095	1.00	.375	.330	.92	.47	.63	.23	.81
BCCH-31-125	BCCS-31-125	5/16	.3110	.3095	1.25	.375	.330	.92	.47	.63	.23	.81
BCCH-31-150	BCCS-31-150	5/16	.3110	.3095	1.50	.375	.330	.92	.47	.63	.23	.81
BCCH-31-200	BCCS-31-200	5/16	.3110	.3095	1.75	.375	.330	.92	.47	.63	.23	.81
BCCH-31-200	BCCS-31-200	5/16	.3110	.3095	2.00	.375	.330	.92	.47	.63	.23	.81
BCCH-31-250	BCCS-31-250	5/16	.3110	.3095	2.50	.375	.330	.92	.47	.63	.23	.81
BCCH-31-300	BCCS-31-300	5/16	.3110	.3095	3.00	.375	.330	.92	.47	.63	.23	.81
BCCH-31-350	BCCS-31-350	5/16	.3110	.3095	3.50	.375	.330	.92	.47	.63	.23	.81
BCCH-31-400	BCCS-31-400	5/16	.3110	.3095	4.00	.375	.330	.92	.47	.63	.23	.81



## QUICK RELEASE BALL LOCK PINS

### Stainless Steel Button Handle | Inch (continued)

**MA** MODIFICATIONS AVAILABLE

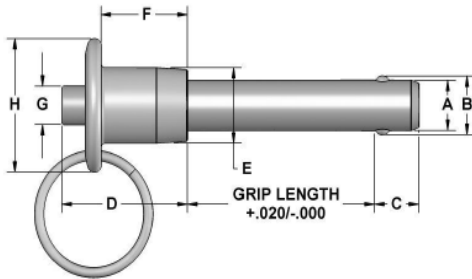

Dia	Hole Size		Min. Pull-Out Strength (lbs)	Calculated Double Shear (lbs)	
	Max	Min		17-4 Stainless	300 Series SS*
3/16	.1940	.1900	200	5,150	—
1/4	.2540	.2500	230	9,200	2,200
5/16	.3165	.3125	510	14,400	3,500
3/8	.3790	.3750	575	20,600	4,500
1/2	.5050	.5000	1,160	36,800	11,500

\*Note: 300 Series Stainless is not recommended in applications where shear forces are a factor.

17-4 SS Part#	300 Series SS Part#	Nominal Diameter	A Max	A Min	Grip Length	+/- .005 B	+ .000/- .030 C	D	E	F	G	H
BCCH-37-050	BCCS-37-050	3/8	.3735	.3720	.50	.440	.365	1.01	.56	.70	.29	1.00
BCCH-37-075	BCCS-37-075	3/8	.3735	.3720	.75	.440	.365	1.01	.56	.70	.29	1.00
BCCH-37-100	BCCS-37-100	3/8	.3735	.3720	1.00	.440	.365	1.01	.56	.70	.29	1.00
BCCH-37-125	BCCS-37-125	3/8	.3735	.3720	1.25	.440	.365	1.01	.56	.70	.29	1.00
BCCH-37-150	BCCS-37-150	3/8	.3735	.3720	1.50	.440	.365	1.01	.56	.70	.29	1.00
BCCH-37-175	BCCS-37-175	3/8	.3735	.3720	1.75	.440	.365	1.01	.56	.70	.29	1.00
BCCH-37-200	BCCS-37-200	3/8	.3735	.3720	2.00	.440	.365	1.01	.56	.70	.29	1.00
BCCH-37-250	BCCS-37-250	3/8	.3735	.3720	2.50	.440	.365	1.01	.56	.70	.29	1.00
BCCH-37-300	BCCS-37-300	3/8	.3735	.3720	3.00	.440	.365	1.01	.56	.70	.29	1.00
BCCH-37-350	BCCS-37-350	3/8	.3735	.3720	3.50	.440	.365	1.01	.56	.70	.29	1.00
BCCH-37-400	BCCS-37-400	3/8	.3735	.3720	4.00	.440	.365	1.01	.56	.70	.29	1.00
BCCH-50-100	BCCS-50-100	1/2	.4985	.4970	1.00	.594	.460	1.27	.72	.85	.42	1.37
BCCH-50-125	BCCS-50-125	1/2	.4985	.4970	1.25	.594	.460	1.27	.72	.85	.42	1.37
BCCH-50-150	BCCS-50-150	1/2	.4985	.4970	1.50	.594	.460	1.27	.72	.85	.42	1.37
BCCH-50-175	BCCS-50-175	1/2	.4985	.4970	1.75	.594	.460	1.27	.72	.85	.42	1.37
BCCH-50-200	BCCS-50-200	1/2	.4985	.4970	2.00	.594	.460	1.27	.72	.85	.42	1.37
BCCH-50-250	BCCS-50-250	1/2	.4985	.4970	2.50	.594	.460	1.27	.72	.85	.42	1.37
BCCH-50-300	BCCS-50-300	1/2	.4985	.4970	3.00	.594	.460	1.27	.72	.85	.42	1.37
BCCH-50-350	BCCS-50-350	1/2	.4985	.4970	3.50	.594	.460	1.27	.72	.85	.42	1.37
BCCH-50-400	BCCS-50-400	1/2	.4985	.4970	4.00	.594	.460	1.27	.72	.85	.42	1.37
BCCH-50-450	BCCS-50-450	1/2	.4985	.4970	4.50	.594	.460	1.27	.72	.85	.42	1.37
BCCH-50-500	BCCS-50-500	1/2	.4985	.4970	5.00	.594	.460	1.27	.72	.85	.42	1.37
BCCH-50-550	BCCS-50-550	1/2	.4985	.4970	5.50	.594	.460	1.27	.72	.85	.42	1.37
BCCH-50-600	BCCS-50-600	1/2	.4985	.4970	6.00	.594	.460	1.27	.72	.85	.42	1.37

## QUICK RELEASE BALL LOCK PINS

### Stainless Steel Button Handle | Metric

**MA** MODIFICATIONS AVAILABLE

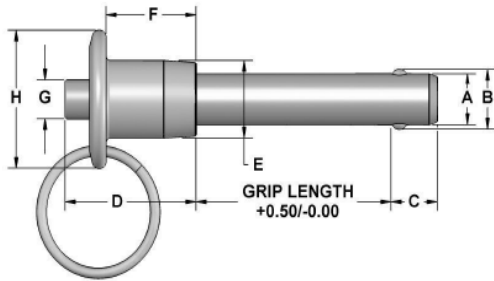

Dia mm	Hole Size Max mm	Hole Size Min mm	Min. Pull-Out Strength (N)	Calculated Double Shear (N) 17-4 Stainless
5	5.1	5.0	890	24,400
6	6.1	6.0	1,023	35,640
8	8.1	8.0	2,268	63,804
10	10.1	10.0	2,558	100,101
12	12.1	12.0	5,160	144,060

These positive locking quick release pins have a wide range of uses in fastening, locating, and alignment applications. The pins will not release until the button on the handle is depressed. Once the button is depressed, the balls retract into the shank allowing the pin to be inserted or removed into or out of a hole. The handles for the pins listed below are made from 303 stainless steel. The shanks are made from 17-4PH stainless steel. The pins are supplied with a stainless steel split ring for attaching a cable assembly. For specific application requirements, custom modifications are available for this product line. See page 3 for complete specifications. RoHS compliant.

17-4 SS Part#	Nominal Diameter mm	A Max mm	A Min mm	Grip Length mm	+/-0.25 B mm	+/-1.0 C mm	D mm	E mm	F mm	G mm	H mm
MBCCH-05-010	5	4.96	4.92	10	5.54	6	23.4	11.9	16	5.8	20.6
MBCCH-05-015	5	4.96	4.92	15	5.54	6	23.4	11.9	16	5.8	20.6
MBCCH-05-020	5	4.96	4.92	20	5.54	6	23.4	11.9	16	5.8	20.6
MBCCH-05-025	5	4.96	4.92	25	5.54	6	23.4	11.9	16	5.8	20.6
MBCCH-05-030	5	4.96	4.92	30	5.54	6	23.4	11.9	16	5.8	20.6
MBCCH-05-035	5	4.96	4.92	35	5.54	6	23.4	11.9	16	5.8	20.6
MBCCH-05-040	5	4.96	4.92	40	5.54	6	23.4	11.9	16	5.8	20.6
MBCCH-05-045	5	4.96	4.92	45	5.54	6	23.4	11.9	16	5.8	20.6
MBCCH-05-050	5	4.96	4.92	50	5.54	6	23.4	11.9	16	5.8	20.6
MBCCH-05-060	5	4.96	4.92	60	5.54	6	23.4	11.9	16	5.8	20.6
MBCCH-05-070	5	4.96	4.92	70	5.54	6	23.4	11.9	16	5.8	20.6
MBCCH-05-080	5	4.96	4.92	80	5.54	6	23.4	11.9	16	5.8	20.6
MBCCH-05-090	5	4.96	4.92	90	5.54	6	23.4	11.9	16	5.8	20.6
MBCCH-05-100	5	4.96	4.92	100	5.54	6	23.4	11.9	16	5.8	20.6
MBCCH-06-010	6	5.96	5.92	10	6.99	7	23.4	11.9	16	5.8	20.6
MBCCH-06-015	6	5.96	5.92	15	6.99	7	23.4	11.9	16	5.8	20.6
MBCCH-06-020	6	5.96	5.92	20	6.99	7	23.4	11.9	16	5.8	20.6
MBCCH-06-025	6	5.96	5.92	25	6.99	7	23.4	11.9	16	5.8	20.6
MBCCH-06-030	6	5.96	5.92	30	6.99	7	23.4	11.9	16	5.8	20.6
MBCCH-06-035	6	5.96	5.92	35	6.99	7	23.4	11.9	16	5.8	20.6
MBCCH-06-040	6	5.96	5.92	40	6.99	7	23.4	11.9	16	5.8	20.6
MBCCH-06-045	6	5.96	5.92	45	6.99	7	23.4	11.9	16	5.8	20.6
MBCCH-06-050	6	5.96	5.92	50	6.99	7	23.4	11.9	16	5.8	20.6
MBCCH-06-060	6	5.96	5.92	60	6.99	7	23.4	11.9	16	5.8	20.6
MBCCH-06-070	6	5.96	5.92	70	6.99	7	23.4	11.9	16	5.8	20.6
MBCCH-06-080	6	5.96	5.92	80	6.99	7	23.4	11.9	16	5.8	20.6
MBCCH-06-090	6	5.96	5.92	90	6.99	7	23.4	11.9	16	5.8	20.6
MBCCH-06-100	6	5.96	5.92	100	6.99	7	23.4	11.9	16	5.8	20.6
MBCCH-08-010	8	7.96	7.92	10	9.42	8	23.4	11.9	16	5.8	20.6
MBCCH-08-015	8	7.96	7.92	15	9.42	8	23.4	11.9	16	5.8	20.6
MBCCH-08-020	8	7.96	7.92	20	9.42	8	23.4	11.9	16	5.8	20.6
MBCCH-08-025	8	7.96	7.92	25	9.42	8	23.4	11.9	16	5.8	20.6
MBCCH-08-030	8	7.96	7.92	30	9.42	8	23.4	11.9	16	5.8	20.6
MBCCH-08-035	8	7.96	7.92	35	9.42	8	23.4	11.9	16	5.8	20.6
MBCCH-08-040	8	7.96	7.92	40	9.42	8	23.4	11.9	16	5.8	20.6
MBCCH-08-045	8	7.96	7.92	45	9.42	8	23.4	11.9	16	5.8	20.6
MBCCH-08-050	8	7.96	7.92	50	9.42	8	23.4	11.9	16	5.8	20.6
MBCCH-08-060	8	7.96	7.92	60	9.42	8	23.4	11.9	16	5.8	20.6
MBCCH-08-070	8	7.96	7.92	70	9.42	8	23.4	11.9	16	5.8	20.6
MBCCH-08-080	8	7.96	7.92	80	9.42	8	23.4	11.9	16	5.8	20.6
MBCCH-08-090	8	7.96	7.92	90	9.42	8	23.4	11.9	16	5.8	20.6
MBCCH-08-100	8	7.96	7.92	100	9.42	8	23.4	11.9	16	5.8	20.6



## QUICK RELEASE BALL LOCK PINS

### Stainless Steel Button Handle | Metric (continued)

**MA** MODIFICATIONS AVAILABLE

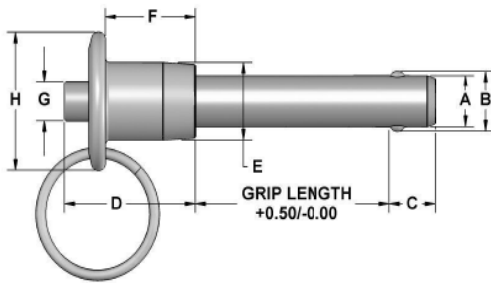

Dia mm	Hole Size Max mm	Hole Size Min mm	Min. Pull-Out Strength (N)	Calculated Double Shear (N) 17-4 Stainless
5	5.1	5.0	890	24,400
6	6.1	6.0	1,023	35,640
8	8.1	8.0	2,268	63,804
10	10.1	10.0	2,558	100,101
12	12.1	12.0	5,160	144,060

17-4 SS Part #	Nominal Diameter mm	A Max mm	A Min mm	Grip Length mm	+/-0.25 B mm	+/-1.0 C mm	D mm	E mm	F mm	G mm	H mm
MBCCH-10-015	10	9.96	9.92	15	11.86	9	25.7	14.2	17.8	7.4	25.4
MBCCH-10-020	10	9.96	9.92	20	11.86	9	25.7	14.2	17.8	7.4	25.4
MBCCH-10-025	10	9.96	9.92	25	11.86	9	25.7	14.2	17.8	7.4	25.4
MBCCH-10-030	10	9.96	9.92	30	11.86	9	25.7	14.2	17.8	7.4	25.4
MBCCH-10-035	10	9.96	9.92	35	11.86	9	25.7	14.2	17.8	7.4	25.4
MBCCH-10-040	10	9.96	9.92	40	11.86	9	25.7	14.2	17.8	7.4	25.4
MBCCH-10-045	10	9.96	9.92	45	11.86	9	25.7	14.2	17.8	7.4	25.4
MBCCH-10-050	10	9.96	9.92	50	11.86	9	25.7	14.2	17.8	7.4	25.4
MBCCH-10-060	10	9.96	9.92	60	11.86	9	25.7	14.2	17.8	7.4	25.4
MBCCH-10-070	10	9.96	9.92	70	11.86	9	25.7	14.2	17.8	7.4	25.4
MBCCH-10-080	10	9.96	9.92	80	11.86	9	25.7	14.2	17.8	7.4	25.4
MBCCH-10-090	10	9.96	9.92	90	11.86	9	25.7	14.2	17.8	7.4	25.4
MBCCH-10-100	10	9.96	9.92	100	11.86	9	25.7	14.2	17.8	7.4	25.4
MBCCH-12-020	12	11.96	11.92	20	14.45	10	32.3	18.3	21.6	10.7	34.7
MBCCH-12-025	12	11.96	11.92	25	14.45	10	32.3	18.3	21.6	10.7	34.7
MBCCH-12-030	12	11.96	11.92	30	14.45	10	32.3	18.3	21.6	10.7	34.7
MBCCH-12-035	12	11.96	11.92	35	14.45	10	32.3	18.3	21.6	10.7	34.7
MBCCH-12-040	12	11.96	11.92	40	14.45	10	32.3	18.3	21.6	10.7	34.7
MBCCH-12-045	12	11.96	11.92	45	14.45	10	32.3	18.3	21.6	10.7	34.7
MBCCH-12-050	12	11.96	11.92	50	14.45	10	32.3	18.3	21.6	10.7	34.7
MBCCH-12-060	12	11.96	11.92	60	14.45	10	32.3	18.3	21.6	10.7	34.7
MBCCH-12-070	12	11.96	11.92	70	14.45	10	32.3	18.3	21.6	10.7	34.7
MBCCH-12-080	12	11.96	11.92	80	14.45	10	32.3	18.3	21.6	10.7	34.7
MBCCH-12-090	12	11.96	11.92	90	14.45	10	32.3	18.3	21.6	10.7	34.7
MBCCH-12-100	12	11.96	11.92	100	14.45	10	32.3	18.3	21.6	10.7	34.7

# QUICK RELEASE BALL LOCK PINS

## Aluminum Ring Handle | Inch

**MA** MODIFICATIONS AVAILABLE

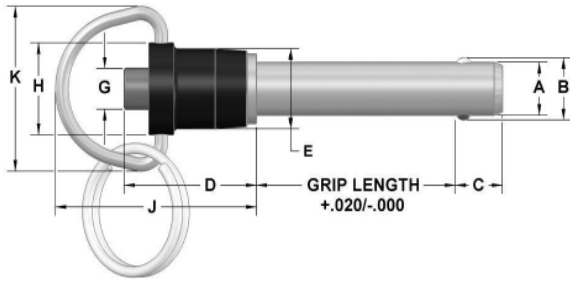

Dia	Hole Size		Min. Pull-Out Strength (lbs)	Calculated Double Shear (lbs)		
	Max	Min		4130 Steel	17-4 Stainless	300 Series SS*
3/16	.1940	.1900	200	4,600	5,150	—
1/4	.2540	.2500	230	8,200	9,200	2,200
5/16	.3165	.3125	510	12,800	14,400	3,500
3/8	.3790	.3750	575	18,400	20,600	4,500
1/2	.5050	.5000	1,160	32,800	36,800	11,500
5/8	.6300	.6250	2,070	51,200	57,500	—

\*Note: 300 Series Stainless is not recommended in applications where shear forces are a factor.

These positive locking quick release pins have a wide range of uses in fastening, locating, and alignment applications. The pins will not release until the button on the handle is depressed. Once the button is depressed, the balls retract into the shank allowing the pin to be inserted or removed into or out of a hole. They are available in three shank materials to meet your application. The handles for the pins listed below are made from 2024-T4 aluminum and anodized black. Stainless handles are also available. The pins are supplied with a stainless steel split ring for attaching a cable assembly. In addition to the standard sizes shown below, custom solutions and additional sizes are available as special order. See page 3 for complete specifications.

4130 Steel Part #	17-4 SS Part #	300 Series SS Part #	Nominal Diameter	A Max	A Min	Grip Length	+/- .005 B	+ .000/- .030 C	D	E	G	H	J	K
RAAS-18-050	RACH-18-050	—	3/16	.1885	.1870	.50	.220	.260	.92	.47	.23	.59	1.45	1.16
RAAS-18-075	RACH-18-075	—	3/16	.1885	.1870	.75	.220	.260	.92	.47	.23	.59	1.45	1.16
RAAS-18-100	RACH-18-100	—	3/16	.1885	.1870	1.00	.220	.260	.92	.47	.23	.59	1.45	1.16
RAAS-18-125	RACH-18-125	—	3/16	.1885	.1870	1.25	.220	.260	.92	.47	.23	.59	1.45	1.16
RAAS-18-150	RACH-18-150	—	3/16	.1885	.1870	1.50	.220	.260	.92	.47	.23	.59	1.45	1.16
RAAS-18-175	RACH-18-175	—	3/16	.1885	.1870	1.75	.220	.260	.92	.47	.23	.59	1.45	1.16
RAAS-18-200	RACH-18-200	—	3/16	.1885	.1870	2.00	.220	.260	.92	.47	.23	.59	1.45	1.16
RAAS-18-250	RACH-18-250	—	3/16	.1885	.1870	2.50	.220	.260	.92	.47	.23	.59	1.45	1.16
RAAS-18-300	RACH-18-300	—	3/16	.1885	.1870	3.00	.220	.260	.92	.47	.23	.59	1.45	1.16
RAAS-18-350	RACH-18-350	—	3/16	.1885	.1870	3.50	.220	.260	.92	.47	.23	.59	1.45	1.16
RAAS-18-400	RACH-18-400	—	3/16	.1885	.1870	4.00	.220	.260	.92	.47	.23	.59	1.45	1.16
RAAS-25-050	RACH-25-050	RACS-25-050	1/4	.2485	.2470	.50	.289	.290	.92	.47	.23	.59	1.45	1.16
RAAS-25-075	RACH-25-075	RACS-25-075	1/4	.2485	.2470	.75	.289	.290	.92	.47	.23	.59	1.45	1.16
RAAS-25-100	RACH-25-100	RACS-25-100	1/4	.2485	.2470	1.00	.289	.290	.92	.47	.23	.59	1.45	1.16
RAAS-25-125	RACH-25-125	RACS-25-125	1/4	.2485	.2470	1.25	.289	.290	.92	.47	.23	.59	1.45	1.16
RAAS-25-150	RACH-25-150	RACS-25-150	1/4	.2485	.2470	1.50	.289	.290	.92	.47	.23	.59	1.45	1.16
RAAS-25-175	RACH-25-175	RACS-25-175	1/4	.2485	.2470	1.75	.289	.290	.92	.47	.23	.59	1.45	1.16
RAAS-25-200	RACH-25-200	RACS-25-200	1/4	.2485	.2470	2.00	.289	.290	.92	.47	.23	.59	1.45	1.16
RAAS-25-250	RACH-25-250	RACS-25-250	1/4	.2485	.2470	2.50	.289	.290	.92	.47	.23	.59	1.45	1.16
RAAS-25-300	RACH-25-300	RACS-25-300	1/4	.2485	.2470	3.00	.289	.290	.92	.47	.23	.59	1.45	1.16
RAAS-25-350	RACH-25-350	RACS-25-350	1/4	.2485	.2470	3.50	.289	.290	.92	.47	.23	.59	1.45	1.16
RAAS-25-400	RACH-25-400	RACS-25-400	1/4	.2485	.2470	4.00	.289	.290	.92	.47	.23	.59	1.45	1.16
RAAS-31-050	RACH-31-050	RACS-31-050	5/16	.3110	.3095	.50	.375	.330	.92	.47	.23	.59	1.45	1.16
RAAS-31-075	RACH-31-075	RACS-31-075	5/16	.3110	.3095	.75	.375	.330	.92	.47	.23	.59	1.45	1.16
RAAS-31-100	RACH-31-100	RACS-31-100	5/16	.3110	.3095	1.00	.375	.330	.92	.47	.23	.59	1.45	1.16
RAAS-31-125	RACH-31-125	RACS-31-125	5/16	.3110	.3095	1.25	.375	.330	.92	.47	.23	.59	1.45	1.16
RAAS-31-150	RACH-31-150	RACS-31-150	5/16	.3110	.3095	1.50	.375	.330	.92	.47	.23	.59	1.45	1.16
RAAS-31-175	RACH-31-175	RACS-31-175	5/16	.3110	.3095	1.75	.375	.330	.92	.47	.23	.59	1.45	1.16
RAAS-31-200	RACH-31-200	RACS-31-200	5/16	.3110	.3095	2.00	.375	.330	.92	.47	.23	.59	1.45	1.16
RAAS-31-250	RACH-31-250	RACS-31-250	5/16	.3110	.3095	2.50	.375	.330	.92	.47	.23	.59	1.45	1.16
RAAS-31-300	RACH-31-300	RACS-31-300	5/16	.3110	.3095	3.00	.375	.330	.92	.47	.23	.59	1.45	1.16
RAAS-31-350	RACH-31-350	RACS-31-350	5/16	.3110	.3095	3.50	.375	.330	.92	.47	.23	.59	1.45	1.16
RAAS-31-400	RACH-31-400	RACS-31-400	5/16	.3110	.3095	4.00	.375	.330	.92	.47	.23	.59	1.45	1.16



# QUICK RELEASE BALL LOCK PINS

## Aluminum Ring Handle 1 Inch (continued)

**MA** MODIFICATIONS AVAILABLE

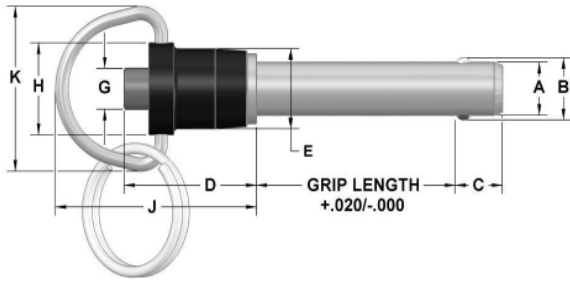

Dia	Hole Size		Min. Pull-Out Strength (lbs)	Calculated Double Shear (lbs)		
	Max	Min		4130 Steel	17-4 Stainless	300 Series SS*
3/16	.1940	.1900	200	4,600	5,150	—
1/4	.2540	.2500	230	8,200	9,200	2,200
5/16	.3165	.3125	510	12,800	14,400	3,500
3/8	.3790	.3750	575	18,400	20,600	4,500
1/2	.5050	.5000	1,160	32,800	36,800	11,500
5/8	.6300	.6250	2,070	51,200	57,500	—

\*Note: 300 Series Stainless is not recommended in applications where shear forces are a factor.

4130 Steel Part #	17-4 SS Part #	300 Series SS Part #	Nominal Diameter	A Max	A Min	Grip Length	+/- .005 B	+ .000/- .030 C	D	E	G	H	J	K
RAAS-37-050	RACH-37-050	RACS-37-050	3/8	.3735	.3720	.50	.440	.365	1.01	.56	.29	.65	1.52	1.16
RAAS-37-075	RACH-37-075	RACS-37-075	3/8	.3735	.3720	.75	.440	.365	1.01	.56	.29	.65	1.52	1.16
RAAS-37-100	RACH-37-100	RACS-37-100	3/8	.3735	.3720	1.00	.440	.365	1.01	.56	.29	.65	1.52	1.16
RAAS-37-125	RACH-37-125	RACS-37-125	3/8	.3735	.3720	1.25	.440	.365	1.01	.56	.29	.65	1.52	1.16
RAAS-37-150	RACH-37-150	RACS-37-150	3/8	.3735	.3720	1.50	.440	.365	1.01	.56	.29	.65	1.52	1.16
RAAS-37-175	RACH-37-175	RACS-37-175	3/8	.3735	.3720	1.75	.440	.365	1.01	.56	.29	.65	1.52	1.16
RAAS-37-200	RACH-37-200	RACS-37-200	3/8	.3735	.3720	2.00	.440	.365	1.01	.56	.29	.65	1.52	1.16
RAAS-37-250	RACH-37-250	RACS-37-250	3/8	.3735	.3720	2.50	.440	.365	1.01	.56	.29	.65	1.52	1.16
RAAS-37-300	RACH-37-300	RACS-37-300	3/8	.3735	.3720	3.00	.440	.365	1.01	.56	.29	.65	1.52	1.16
RAAS-37-350	RACH-37-350	RACS-37-350	3/8	.3735	.3720	3.50	.440	.365	1.01	.56	.29	.65	1.52	1.16
RAAS-37-400	RACH-37-400	RACS-37-400	3/8	.3735	.3720	4.00	.440	.365	1.01	.56	.29	.65	1.52	1.16
RAAS-50-100	RACH-50-100	RACS-50-100	1/2	.4985	.4970	1.00	.594	.460	1.27	.72	.42	.81	1.88	1.43
RAAS-50-125	RACH-50-125	RACS-50-125	1/2	.4985	.4970	1.25	.594	.460	1.27	.72	.42	.81	1.88	1.43
RAAS-50-150	RACH-50-150	RACS-50-150	1/2	.4985	.4970	1.50	.594	.460	1.27	.72	.42	.81	1.88	1.43
RAAS-50-175	RACH-50-175	RACS-50-175	1/2	.4985	.4970	1.75	.594	.460	1.27	.72	.42	.81	1.88	1.43
RAAS-50-200	RACH-50-200	RACS-50-200	1/2	.4985	.4970	2.00	.594	.460	1.27	.72	.42	.81	1.88	1.43
RAAS-50-250	RACH-50-250	RACS-50-250	1/2	.4985	.4970	2.50	.594	.460	1.27	.72	.42	.81	1.88	1.43
RAAS-50-300	RACH-50-300	RACS-50-300	1/2	.4985	.4970	3.00	.594	.460	1.27	.72	.42	.81	1.88	1.43
RAAS-50-350	RACH-50-350	RACS-50-350	1/2	.4985	.4970	3.50	.594	.460	1.27	.72	.42	.81	1.88	1.43
RAAS-50-400	RACH-50-400	RACS-50-400	1/2	.4985	.4970	4.00	.594	.460	1.27	.72	.42	.81	1.88	1.43
RAAS-50-450	RACH-50-450	RACS-50-450	1/2	.4985	.4970	4.50	.594	.460	1.27	.72	.42	.81	1.88	1.43
RAAS-50-500	RACH-50-500	RACS-50-500	1/2	.4985	.4970	5.00	.594	.460	1.27	.72	.42	.81	1.88	1.43
RAAS-50-550	RACH-50-550	RACS-50-550	1/2	.4985	.4970	5.50	.594	.460	1.27	.72	.42	.81	1.88	1.43
RAAS-50-600	RACH-50-600	RACS-50-600	1/2	.4985	.4970	6.00	.594	.460	1.27	.72	.42	.81	1.88	1.43
RAAS-62-150	RACH-62-150	—	5/8	.6235	.6220	1.50	.750	.580	1.65	.94	.54	1.06	2.57	1.72
RAAS-62-175	RACH-62-175	—	5/8	.6235	.6220	1.75	.750	.580	1.65	.94	.54	1.06	2.57	1.72
RAAS-62-200	RACH-62-200	—	5/8	.6235	.6220	2.00	.750	.580	1.65	.94	.54	1.06	2.57	1.72
RAAS-62-250	RACH-62-250	—	5/8	.6235	.6220	2.50	.750	.580	1.65	.94	.54	1.06	2.57	1.72
RAAS-62-300	RACH-62-300	—	5/8	.6235	.6220	3.00	.750	.580	1.65	.94	.54	1.06	2.57	1.72
RAAS-62-350	RACH-62-350	—	5/8	.6235	.6220	3.50	.750	.580	1.65	.94	.54	1.06	2.57	1.72
RAAS-62-400	RACH-62-400	—	5/8	.6235	.6220	4.00	.750	.580	1.65	.94	.54	1.06	2.57	1.72
RAAS-62-450	RACH-62-450	—	5/8	.6235	.6220	4.50	.750	.580	1.65	.94	.54	1.06	2.57	1.72
RAAS-62-500	RACH-62-500	—	5/8	.6235	.6220	5.00	.750	.580	1.65	.94	.54	1.06	2.57	1.72
RAAS-62-550	RACH-62-550	—	5/8	.6235	.6220	5.50	.750	.580	1.65	.94	.54	1.06	2.57	1.72
RAAS-62-600	RACH-62-600	—	5/8	.6235	.6220	6.00	.750	.580	1.65	.94	.54	1.06	2.57	1.72

## QUICK RELEASE BALL LOCK PINS

### Aluminum Ring Handle | Metric

**MA** MODIFICATIONS AVAILABLE

**EXPANDED LINE**

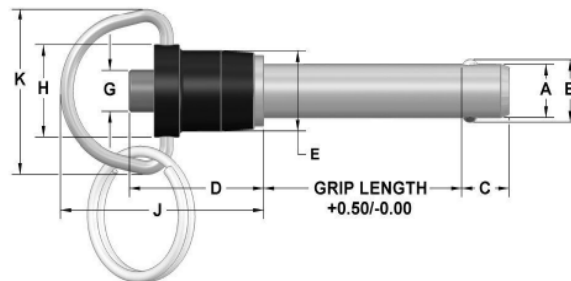

Dia mm	Hole Size mm		Min. Pull-Out Strength (N)	Calculated Double Shear (N)	
	Max	Min		4130 Steel	17-4 Stainless
5	5.1	5.0	890	21,600	24,400
6	6.1	6.0	1,023	31,686	35,640
8	8.1	8.0	2,268	56,712	63,804
10	10.1	10.0	2,558	88,977	100,101
12	12.1	12.0	5,160	128,050	144,060
16	16.1	16.0	9,207	228,602	257,179

These positive locking quick release pins have a wide range of uses in fastening, locating, and alignment applications. The pins will not release until the button on the handle is depressed. Once the button is depressed, the balls retract into the shank allowing the pin to be inserted or removed into or out of a hole. The shanks are available in 4130 steel with zinc plating or 17-4PH stainless steel. The handles for the pins listed below are made from 2024-T4 aluminum and anodized black. Stainless handles are also available. The pins are supplied with a stainless steel split ring for attaching a cable assembly. For specific application requirements, custom modifications are available for this product line. See page 3 for complete specifications. RoHS compliant.

4130 Steel Part #	17-4SS Part #	Nominal Diameter mm	A Max mm	A Min mm	Grip Length mm	+/-0.25 B mm	+/-1.0 C mm	D mm	E mm	F mm	G mm	H mm	K mm
MRAAS-05-010	MRACH-05-010	5	4.96	4.92	10	5.54	6	23.4	11.9	5.8	15	36.8	29.5
MRAAS-05-015	MRACH-05-015	5	4.96	4.92	15	5.54	6	23.4	11.9	5.8	15	36.8	29.5
MRAAS-05-020	MRACH-05-020	5	4.96	4.92	20	5.54	6	23.4	11.9	5.8	15	36.8	29.5
MRAAS-05-025	MRACH-05-025	5	4.96	4.92	25	5.54	6	23.4	11.9	5.8	15	36.8	29.5
MRAAS-05-030	MRACH-05-030	5	4.96	4.92	30	5.54	6	23.4	11.9	5.8	15	36.8	29.5
MRAAS-05-035	MRACH-05-035	5	4.96	4.92	35	5.54	6	23.4	11.9	5.8	15	36.8	29.5
MRAAS-05-040	MRACH-05-040	5	4.96	4.92	40	5.54	6	23.4	11.9	5.8	15	36.8	29.5
MRAAS-05-045	MRACH-05-045	5	4.96	4.92	45	5.54	6	23.4	11.9	5.8	15	36.8	29.5
MRAAS-05-050	MRACH-05-050	5	4.96	4.92	50	5.54	6	23.4	11.9	5.8	15	36.8	29.5
MRAAS-05-060	MRACH-05-060	5	4.96	4.92	60	5.54	6	23.4	11.9	5.8	15	36.8	29.5
MRAAS-05-070	MRACH-05-070	5	4.96	4.92	70	5.54	6	23.4	11.9	5.8	15	36.8	29.5
MRAAS-05-080	MRACH-05-080	5	4.96	4.92	80	5.54	6	23.4	11.9	5.8	15	36.8	29.5
MRAAS-05-090	MRACH-05-090	5	4.96	4.92	90	5.54	6	23.4	11.9	5.8	15	36.8	29.5
MRAAS-05-100	MRACH-05-100	5	4.96	4.92	100	5.54	6	23.4	11.9	5.8	15	36.8	29.5
MRAAS-06-010	MRACH-06-010	6	5.96	5.92	10	6.99	7	23.4	11.9	5.8	15	36.8	29.5
MRAAS-06-015	MRACH-06-015	6	5.96	5.92	15	6.99	7	23.4	11.9	5.8	15	36.8	29.5
MRAAS-06-020	MRACH-06-020	6	5.96	5.92	20	6.99	7	23.4	11.9	5.8	15	36.8	29.5
MRAAS-06-025	MRACH-06-025	6	5.96	5.92	25	6.99	7	23.4	11.9	5.8	15	36.8	29.5
MRAAS-06-030	MRACH-06-030	6	5.96	5.92	30	6.99	7	23.4	11.9	5.8	15	36.8	29.5
MRAAS-06-035	MRACH-06-035	6	5.96	5.92	35	6.99	7	23.4	11.9	5.8	15	36.8	29.5
MRAAS-06-040	MRACH-06-040	6	5.96	5.92	40	6.99	7	23.4	11.9	5.8	15	36.8	29.5
MRAAS-06-045	MRACH-06-045	6	5.96	5.92	45	6.99	7	23.4	11.9	5.8	15	36.8	29.5
MRAAS-06-050	MRACH-06-050	6	5.96	5.92	50	6.99	7	23.4	11.9	5.8	15	36.8	29.5
MRAAS-06-060	MRACH-06-060	6	5.96	5.92	60	6.99	7	23.4	11.9	5.8	15	36.8	29.5
MRAAS-06-070	MRACH-06-070	6	5.96	5.92	70	6.99	7	23.4	11.9	5.8	15	36.8	29.5
MRAAS-06-080	MRACH-06-080	6	5.96	5.92	80	6.99	7	23.4	11.9	5.8	15	36.8	29.5
MRAAS-06-090	MRACH-06-090	6	5.96	5.92	90	6.99	7	23.4	11.9	5.8	15	36.8	29.5
MRAAS-06-100	MRACH-06-100	6	5.96	5.92	100	6.99	7	23.4	11.9	5.8	15	36.8	29.5
MRAAS-08-010	MRACH-08-010	8	7.96	7.92	10	9.42	8	23.4	11.9	5.8	15	36.8	29.5
MRAAS-08-015	MRACH-08-015	8	7.96	7.92	15	9.42	8	23.4	11.9	5.8	15	36.8	29.5
MRAAS-08-020	MRACH-08-020	8	7.96	7.92	20	9.42	8	23.4	11.9	5.8	15	36.8	29.5
MRAAS-08-025	MRACH-08-025	8	7.96	7.92	25	9.42	8	23.4	11.9	5.8	15	36.8	29.5
MRAAS-08-030	MRACH-08-030	8	7.96	7.92	30	9.42	8	23.4	11.9	5.8	15	36.8	29.5
MRAAS-08-035	MRACH-08-035	8	7.96	7.92	35	9.42	8	23.4	11.9	5.8	15	36.8	29.5
MRAAS-08-040	MRACH-08-040	8	7.96	7.92	40	9.42	8	23.4	11.9	5.8	15	36.8	29.5
MRAAS-08-045	MRACH-08-045	8	7.96	7.92	45	9.42	8	23.4	11.9	5.8	15	36.8	29.5
MRAAS-08-050	MRACH-08-050	8	7.96	7.92	50	9.42	8	23.4	11.9	5.8	15	36.8	29.5
MRAAS-08-060	MRACH-08-060	8	7.96	7.92	60	9.42	8	23.4	11.9	5.8	15	36.8	29.5
MRAAS-08-070	MRACH-08-070	8	7.96	7.92	70	9.42	8	23.4	11.9	5.8	15	36.8	29.5
MRAAS-08-080	MRACH-08-080	8	7.96	7.92	80	9.42	8	23.4	11.9	5.8	15	36.8	29.5
MRAAS-08-090	MRACH-08-090	8	7.96	7.92	90	9.42	8	23.4	11.9	5.8	15	36.8	29.5
MRAAS-08-100	MRACH-08-100	8	7.96	7.92	100	9.42	8	23.4	11.9	5.8	15	36.8	29.5



# QUICK RELEASE BALL LOCK PINS

## Aluminum Ring Handle | Metric (continued)

**MA** MODIFICATIONS AVAILABLE

**EXPANDED LINE**

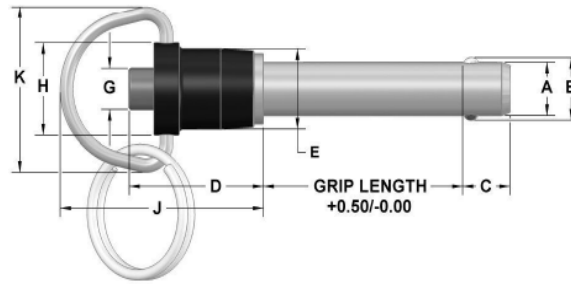

Dia mm	Hole Size		Min. Pull-Out Strength (N)	Calculated Double Shear (N)	
	Max mm	Min mm		4130 Steel	17-4 Stainless
5	5.1	5.0	890	21,600	24,400
6	6.1	6.0	1,023	31,686	35,640
8	8.1	8.0	2,268	56,712	63,804
10	10.1	10.0	2,558	88,977	100,101
12	12.1	12.0	5,160	128,050	144,060
16	16.1	16.0	9,207	228,602	257,179

4130 Steel Part#	17-4 SS Part#	Nominal Diameter mm	A Max mm	A Min mm	Grip Length mm	+/-0.25 B mm	+/-1.0 C mm	D mm	E mm	F mm	G mm	H mm	K mm
MRAAS-10-015	MRACH-10-015	10	9.96	9.92	15	11.86	9	25.7	14.2	7.4	16.5	38.6	29.5
MRAAS-10-020	MRACH-10-020	10	9.96	9.92	20	11.86	9	25.7	14.2	7.4	16.5	38.6	29.5
MRAAS-10-025	MRACH-10-025	10	9.96	9.92	25	11.86	9	25.7	14.2	7.4	16.5	38.6	29.5
MRAAS-10-030	MRACH-10-030	10	9.96	9.92	30	11.86	9	25.7	14.2	7.4	16.5	38.6	29.5
MRAAS-10-035	MRACH-10-035	10	9.96	9.92	35	11.86	9	25.7	14.2	7.4	16.5	38.6	29.5
MRAAS-10-040	MRACH-10-040	10	9.96	9.92	40	11.86	9	25.7	14.2	7.4	16.5	38.6	29.5
MRAAS-10-045	MRACH-10-045	10	9.96	9.92	45	11.86	9	25.7	14.2	7.4	16.5	38.6	29.5
MRAAS-10-050	MRACH-10-050	10	9.96	9.92	50	11.86	9	25.7	14.2	7.4	16.5	38.6	29.5
MRAAS-10-060	MRACH-10-060	10	9.96	9.92	60	11.86	9	25.7	14.2	7.4	16.5	38.6	29.5
MRAAS-10-070	MRACH-10-070	10	9.96	9.92	70	11.86	9	25.7	14.2	7.4	16.5	38.6	29.5
MRAAS-10-080	MRACH-10-080	10	9.96	9.92	80	11.86	9	25.7	14.2	7.4	16.5	38.6	29.5
MRAAS-10-090	MRACH-10-090	10	9.96	9.92	90	11.86	9	25.7	14.2	7.4	16.5	38.6	29.5
MRAAS-10-100	MRACH-10-100	10	9.96	9.92	100	11.86	9	25.7	14.2	7.4	16.5	38.6	29.5
MRAAS-12-020	MRACH-12-020	12	11.96	11.92	20	14.45	10	32.3	18.3	10.7	20.6	47.8	36.3
MRAAS-12-025	MRACH-12-025	12	11.96	11.92	25	14.45	10	32.3	18.3	10.7	20.6	47.8	36.3
MRAAS-12-030	MRACH-12-030	12	11.96	11.92	30	14.45	10	32.3	18.3	10.7	20.6	47.8	36.3
MRAAS-12-035	MRACH-12-035	12	11.96	11.92	35	14.45	10	32.3	18.3	10.7	20.6	47.8	36.3
MRAAS-12-040	MRACH-12-040	12	11.96	11.92	40	14.45	10	32.3	18.3	10.7	20.6	47.8	36.3
MRAAS-12-045	MRACH-12-045	12	11.96	11.92	45	14.45	10	32.3	18.3	10.7	20.6	47.8	36.3
MRAAS-12-050	MRACH-12-050	12	11.96	11.92	50	14.45	10	32.3	18.3	10.7	20.6	47.8	36.3
MRAAS-12-060	MRACH-12-060	12	11.96	11.92	60	14.45	10	32.3	18.3	10.7	20.6	47.8	36.3
MRAAS-12-070	MRACH-12-070	12	11.96	11.92	70	14.45	10	32.3	18.3	10.7	20.6	47.8	36.3
MRAAS-12-080	MRACH-12-080	12	11.96	11.92	80	14.45	10	32.3	18.3	10.7	20.6	47.8	36.3
MRAAS-12-090	MRACH-12-090	12	11.96	11.92	90	14.45	10	32.3	18.3	10.7	20.6	47.8	36.3
MRAAS-12-100	MRACH-12-100	12	11.96	11.92	100	14.45	10	32.3	18.3	10.7	20.6	47.8	36.3
MRAAS-16-025	MRACH-16-025	16	15.96	15.92	25	19	14	41.9	23.9	13.7	26.9	65.3	43.7
MRAAS-16-030	MRACH-16-030	16	15.96	15.92	30	19	14	41.9	23.9	13.7	26.9	65.3	43.7
MRAAS-16-035	MRACH-16-035	16	15.96	15.92	35	19	14	41.9	23.9	13.7	26.9	65.3	43.7
MRAAS-16-040	MRACH-16-040	16	15.96	15.92	40	19	14	41.9	23.9	13.7	26.9	65.3	43.7
MRAAS-16-045	MRACH-16-045	16	15.96	15.92	45	19	14	41.9	23.9	13.7	26.9	65.3	43.7
MRAAS-16-050	MRACH-16-050	16	15.96	15.92	50	19	14	41.9	23.9	13.7	26.9	65.3	43.7
MRAAS-16-060	MRACH-16-060	16	15.96	15.92	60	19	14	41.9	23.9	13.7	26.9	65.3	43.7
MRAAS-16-070	MRACH-16-070	16	15.96	15.92	70	19	14	41.9	23.9	13.7	26.9	65.3	43.7
MRAAS-16-080	MRACH-16-080	16	15.96	15.92	80	19	14	41.9	23.9	13.7	26.9	65.3	43.7
MRAAS-16-090	MRACH-16-090	16	15.96	15.92	90	19	14	41.9	23.9	13.7	26.9	65.3	43.7
MRAAS-16-100	MRACH-16-100	16	15.96	15.92	100	19	14	41.9	23.9	13.7	26.9	65.3	43.7

# QUICK RELEASE BALL LOCK PINS

## Stainless Steel Ring Handle | Inch

**MA** MODIFICATIONS AVAILABLE

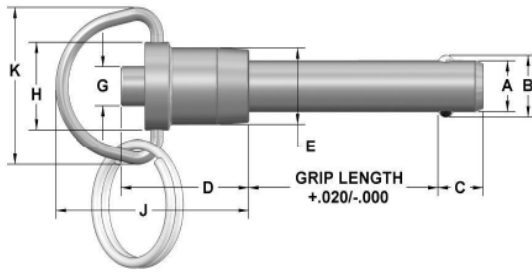

Dia	Hole Size		Min. Pull-Out Strength (lbs)	Calculated Double Shear (lbs)		
	Max	Min		4130 Steel	17-4 Stainless	300 Series SS*
3/16	.1940	.1900	200	4,600	5,150	—
1/4	.2540	.2500	230	8,200	9,200	2,200
5/16	.3165	.3125	510	12,800	14,400	3,500
3/8	.3790	.3750	575	18,400	20,600	4,500
1/2	.5050	.5000	1,160	32,800	36,800	11,500
5/8	.6300	.6250	2,070	51,200	57,500	—

\*Note: 300 Series Stainless is not recommended in applications where shear forces are a factor.

These positive locking quick release pins have a wide range of uses in fastening, locating, and alignment applications. The pins will not release until the button on the handle is depressed. Once the button is depressed, the balls retract into the shank allowing the pin to be inserted or removed into or out of a hole. They are available in two types of stainless steel to meet your application. The handles and actuator buttons for the pins listed below are made from 303 stainless steel. The pins are supplied with a stainless steel split ring for attaching a cable assembly. In addition to the standard sizes shown below, custom solutions and additional sizes are available as special order. See page 3 for complete specifications.

17-4 SS Part #	300 Series SS Part #	Nominal Diameter	A Max	A Min	Grip Length	+/- .005 B	+ .000/- .030 C	D	E	G	H	J	K
RCCH-18-050	—	3/16	.1885	.1870	.50	.220	.260	92	.47	.23	.59	1.45	1.16
RCCH-18-075	—	3/16	.1885	.1870	.75	.220	.260	92	.47	.23	.59	1.45	1.16
RCCH-18-100	—	3/16	.1885	.1870	1.00	.220	.260	92	.47	.23	.59	1.45	1.16
RCCH-18-125	—	3/16	.1885	.1870	1.25	.220	.260	92	.47	.23	.59	1.45	1.16
RCCH-18-150	—	3/16	.1885	.1870	1.50	.220	.260	92	.47	.23	.59	1.45	1.16
RCCH-18-175	—	3/16	.1885	.1870	1.75	.220	.260	92	.47	.23	.59	1.45	1.16
RCCH-18-200	—	3/16	.1885	.1870	2.00	.220	.260	92	.47	.23	.59	1.45	1.16
RCCH-18-250	—	3/16	.1885	.1870	2.50	.220	.260	92	.47	.23	.59	1.45	1.16
RCCH-18-300	—	3/16	.1885	.1870	3.00	.220	.260	92	.47	.23	.59	1.45	1.16
RCCH-18-350	—	3/16	.1885	.1870	3.50	.220	.260	92	.47	.23	.59	1.45	1.16
RCCH-18-400	—	3/16	.1885	.1870	4.00	.220	.260	92	.47	.23	.59	1.45	1.16
RCCH-25-050	RCCS-25-050	1/4	.2485	.2470	.50	.289	.290	92	.47	.23	.59	1.45	1.16
RCCH-25-075	RCCS-25-075	1/4	.2485	.2470	.75	.289	.290	92	.47	.23	.59	1.45	1.16
RCCH-25-100	RCCS-25-100	1/4	.2485	.2470	1.00	.289	.290	92	.47	.23	.59	1.45	1.16
RCCH-25-125	RCCS-25-125	1/4	.2485	.2470	1.25	.289	.290	92	.47	.23	.59	1.45	1.16
RCCH-25-150	RCCS-25-150	1/4	.2485	.2470	1.50	.289	.290	92	.47	.23	.59	1.45	1.16
RCCH-25-175	RCCS-25-175	1/4	.2485	.2470	1.75	.289	.290	92	.47	.23	.59	1.45	1.16
RCCH-25-200	RCCS-25-200	1/4	.2485	.2470	2.00	.289	.290	92	.47	.23	.59	1.45	1.16
RCCH-25-250	RCCS-25-250	1/4	.2485	.2470	2.50	.289	.290	92	.47	.23	.59	1.45	1.16
RCCH-25-300	RCCS-25-300	1/4	.2485	.2470	3.00	.289	.290	92	.47	.23	.59	1.45	1.16
RCCH-25-350	RCCS-25-350	1/4	.2485	.2470	3.50	.289	.290	92	.47	.23	.59	1.45	1.16
RCCH-25-400	RCCS-25-400	1/4	.2485	.2470	4.00	.289	.290	92	.47	.23	.59	1.45	1.16
RCCH-31-050	RCCS-31-050	5/16	.3110	.3095	.50	.375	.330	92	.47	.23	.59	1.45	1.16
RCCH-31-075	RCCS-31-075	5/16	.3110	.3095	.75	.375	.330	92	.47	.23	.59	1.45	1.16
RCCH-31-100	RCCS-31-100	5/16	.3110	.3095	1.00	.375	.330	92	.47	.23	.59	1.45	1.16
RCCH-31-125	RCCS-31-125	5/16	.3110	.3095	1.25	.375	.330	92	.47	.23	.59	1.45	1.16
RCCH-31-150	RCCS-31-150	5/16	.3110	.3095	1.50	.375	.330	92	.47	.23	.59	1.45	1.16
RCCH-31-175	RCCS-31-175	5/16	.3110	.3095	1.75	.375	.330	92	.47	.23	.59	1.45	1.16
RCCH-31-200	RCCS-31-200	5/16	.3110	.3095	2.00	.375	.330	92	.47	.23	.59	1.45	1.16
RCCH-31-250	RCCS-31-250	5/16	.3110	.3095	2.50	.375	.330	92	.47	.23	.59	1.45	1.16
RCCH-31-300	RCCS-31-300	5/16	.3110	.3095	3.00	.375	.330	92	.47	.23	.59	1.45	1.16
RCCH-31-350	RCCS-31-350	5/16	.3110	.3095	3.50	.375	.330	92	.47	.23	.59	1.45	1.16
RCCH-31-400	RCCS-31-400	5/16	.3110	.3095	4.00	.375	.330	92	.47	.23	.59	1.45	1.16



## QUICK RELEASE BALL LOCK PINS

### Stainless Steel Ring Handle | Inch (continued)

**MA** MODIFICATIONS AVAILABLE

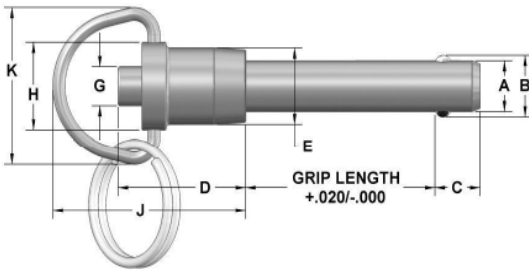

Dia	Hole Size		Min. Pull-Out Strength (lbs)	Calculated Double Shear (lbs)		
	Max	Min		4130 Steel	17-4 Stainless	300 Series SS*
3/16	.1940	.1900	200	4,600	5,150	—
1/4	.2540	.2500	230	8,200	9,200	2,200
5/16	.3165	.3125	510	12,800	14,400	3,500
3/8	.3790	.3750	575	18,400	20,600	4,500
1/2	.5050	.5000	1,160	32,800	36,800	11,500
5/8	.6300	.6250	2,070	51,200	57,500	—

\*Note: 300 Series Stainless is not recommended in applications where shear forces are a factor.

17-4 SS Part #	300 Series SS Part #	Nominal Diameter	A Max	A Min	Grip Length	+/- .005 B	+ .000/- .030 C	D	E	G	H	J	K
RCCH-37-050	RCCS-37-050	3/8	.3735	.3720	.50	.440	.365	1.01	.56	.29	.65	1.52	1.16
RCCH-37-075	RCCS-37-075	3/8	.3735	.3720	.75	.440	.365	1.01	.56	.29	.65	1.52	1.16
RCCH-37-100	RCCS-37-100	3/8	.3735	.3720	1.00	.440	.365	1.01	.56	.29	.65	1.52	1.16
RCCH-37-125	RCCS-37-125	3/8	.3735	.3720	1.25	.440	.365	1.01	.56	.29	.65	1.52	1.16
RCCH-37-150	RCCS-37-150	3/8	.3735	.3720	1.50	.440	.365	1.01	.56	.29	.65	1.52	1.16
RCCH-37-175	RCCS-37-175	3/8	.3735	.3720	1.75	.440	.365	1.01	.56	.29	.65	1.52	1.16
RCCH-37-200	RCCS-37-200	3/8	.3735	.3720	2.00	.440	.365	1.01	.56	.29	.65	1.52	1.16
RCCH-37-250	RCCS-37-250	3/8	.3735	.3720	2.50	.440	.365	1.01	.56	.29	.65	1.52	1.16
RCCH-37-300	RCCS-37-300	3/8	.3735	.3720	3.00	.440	.365	1.01	.56	.29	.65	1.52	1.16
RCCH-37-350	RCCS-37-350	3/8	.3735	.3720	3.50	.440	.365	1.01	.56	.29	.65	1.52	1.16
RCCH-37-400	RCCS-37-400	3/8	.3735	.3720	4.00	.440	.365	1.01	.56	.29	.65	1.52	1.16
RCCH-50-100	RCCS-50-100	1/2	.4985	.4970	1.00	.594	.460	1.27	.72	.42	.81	1.88	1.43
RCCH-50-125	RCCS-50-125	1/2	.4985	.4970	1.25	.594	.460	1.27	.72	.42	.81	1.88	1.43
RCCH-50-150	RCCS-50-150	1/2	.4985	.4970	1.50	.594	.460	1.27	.72	.42	.81	1.88	1.43
RCCH-50-175	RCCS-50-175	1/2	.4985	.4970	1.75	.594	.460	1.27	.72	.42	.81	1.88	1.43
RCCH-50-200	RCCS-50-200	1/2	.4985	.4970	2.00	.594	.460	1.27	.72	.42	.81	1.88	1.43
RCCH-50-250	RCCS-50-250	1/2	.4985	.4970	2.50	.594	.460	1.27	.72	.42	.81	1.88	1.43
RCCH-50-300	RCCS-50-300	1/2	.4985	.4970	3.00	.594	.460	1.27	.72	.42	.81	1.88	1.43
RCCH-50-350	RCCS-50-350	1/2	.4985	.4970	3.50	.594	.460	1.27	.72	.42	.81	1.88	1.43
RCCH-50-400	RCCS-50-400	1/2	.4985	.4970	4.00	.594	.460	1.27	.72	.42	.81	1.88	1.43
RCCH-50-450	RCCS-50-450	1/2	.4985	.4970	4.50	.594	.460	1.27	.72	.42	.81	1.88	1.43
RCCH-50-500	RCCS-50-500	1/2	.4985	.4970	5.00	.594	.460	1.27	.72	.42	.81	1.88	1.43
RCCH-50-550	RCCS-50-550	1/2	.4985	.4970	5.50	.594	.460	1.27	.72	.42	.81	1.88	1.43
RCCH-50-600	RCCS-50-600	1/2	.4985	.4970	6.00	.594	.460	1.27	.72	.42	.81	1.88	1.43
RCCH-62-150	—	5/8	.6235	.6220	1.50	.750	.580	1.65	.94	.54	1.06	2.57	1.72
RCCH-62-175	—	5/8	.6235	.6220	1.75	.750	.580	1.65	.94	.54	1.06	2.57	1.72
RCCH-62-200	—	5/8	.6235	.6220	2.00	.750	.580	1.65	.94	.54	1.06	2.57	1.72
RCCH-62-250	—	5/8	.6235	.6220	2.50	.750	.580	1.65	.94	.54	1.06	2.57	1.72
RCCH-62-300	—	5/8	.6235	.6220	3.00	.750	.580	1.65	.94	.54	1.06	2.57	1.72
RCCH-62-350	—	5/8	.6235	.6220	3.50	.750	.580	1.65	.94	.54	1.06	2.57	1.72
RCCH-62-400	—	5/8	.6235	.6220	4.00	.750	.580	1.65	.94	.54	1.06	2.57	1.72
RCCH-62-450	—	5/8	.6235	.6220	4.50	.750	.580	1.65	.94	.54	1.06	2.57	1.72
RCCH-62-500	—	5/8	.6235	.6220	5.00	.750	.580	1.65	.94	.54	1.06	2.57	1.72
RCCH-62-550	—	5/8	.6235	.6220	5.50	.750	.580	1.65	.94	.54	1.06	2.57	1.72
RCCH-62-600	—	5/8	.6235	.6220	6.00	.750	.580	1.65	.94	.54	1.06	2.57	1.72

## QUICK RELEASE BALL LOCK PINS

### Stainless Steel Ring Handle | Metric

**MA** MODIFICATIONS AVAILABLE

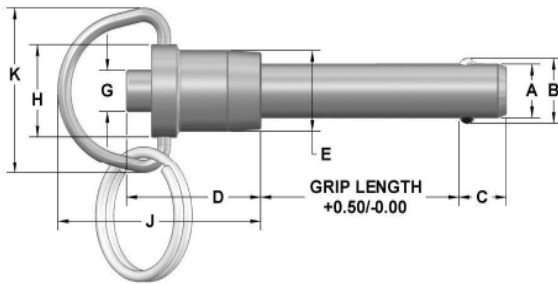

Dia mm	Hole Size Max mm	Min mm	Min. Pull-Out Strength (N)	Calculated Double Shear (N) 17-4 Stainless
5	5.1	5.0	890	24,400
6	6.1	6.0	1,023	35,640
8	8.1	8.0	2,268	63,804
10	10.1	10.0	2,558	100,101
12	12.1	12.0	5,160	144,060
16	16.1	16.0	9,207	257,179

These positive locking quick release pins have a wide range of uses in fastening, locating, and alignment applications. The pins will not release until the button on the handle is depressed. Once the button is depressed, the balls retract into the shank allowing the pin to be inserted or removed into or out of a hole. The handles for the pins listed below are made from 303 stainless steel. The shanks are made from 17-4PH stainless steel. The pins are supplied with a stainless steel split ring for attaching a cable assembly. For specific application requirements, custom modifications are available for this product line. See page 3 for complete specifications. RoHS compliant.

17-4 SS Part#	Nominal Diameter mm	A Max mm	A Min mm	Grip Length mm	+/-0.25 B mm	+/-1.0 C mm	D mm	E mm	G mm	H mm	J mm	K mm
MRCCH-05-010	5	4.96	4.92	10	5.54	6	23.4	11.9	5.8	15	36.8	29.5
MRCCH-05-015	5	4.96	4.92	15	5.54	6	23.4	11.9	5.8	15	36.8	29.5
MRCCH-05-020	5	4.96	4.92	20	5.54	6	23.4	11.9	5.8	15	36.8	29.5
MRCCH-05-025	5	4.96	4.92	25	5.54	6	23.4	11.9	5.8	15	36.8	29.5
MRCCH-05-300	5	4.96	4.92	30	5.54	6	23.4	11.9	5.8	15	36.8	29.5
MRCCH-05-035	5	4.96	4.92	35	5.54	6	23.4	11.9	5.8	15	36.8	29.5
MRCCH-05-040	5	4.96	4.92	40	5.54	6	23.4	11.9	5.8	15	36.8	29.5
MRCCH-05-045	5	4.96	4.92	45	5.54	6	23.4	11.9	5.8	15	36.8	29.5
MRCCH-05-050	5	4.96	4.92	50	5.54	6	23.4	11.9	5.8	15	36.8	29.5
MRCCH-05-060	5	4.96	4.92	60	5.54	6	23.4	11.9	5.8	15	36.8	29.5
MRCCH-05-070	5	4.96	4.92	70	5.54	6	23.4	11.9	5.8	15	36.8	29.5
MRCCH-05-080	5	4.96	4.92	80	5.54	6	23.4	11.9	5.8	15	36.8	29.5
MRCCH-05-090	5	4.96	4.92	90	5.54	6	23.4	11.9	5.8	15	36.8	29.5
MRCCH-05-100	5	4.96	4.92	100	5.54	6	23.4	11.9	5.8	15	36.8	29.5
MRCCH-06-010	6	5.96	5.92	10	6.99	7	23.4	11.9	5.8	15	36.8	29.5
MRCCH-06-015	6	5.96	5.92	15	6.99	7	23.4	11.9	5.8	15	36.8	29.5
MRCCH-06-020	6	5.96	5.92	20	6.99	7	23.4	11.9	5.8	15	36.8	29.5
MRCCH-06-025	6	5.96	5.92	25	6.99	7	23.4	11.9	5.8	15	36.8	29.5
MRCCH-06-030	6	5.96	5.92	30	6.99	7	23.4	11.9	5.8	15	36.8	29.5
MRCCH-06-035	6	5.96	5.92	35	6.99	7	23.1	11.9	5.8	15	36.8	29.5
MRCCH-06-040	6	5.96	5.92	40	6.99	7	23.4	11.9	5.8	15	36.8	29.5
MRCCH-06-045	6	5.96	5.92	45	6.99	7	23.4	11.9	5.8	15	36.8	29.5
MRCCH-06-050	6	5.96	5.92	50	6.99	7	23.4	11.9	5.8	15	36.8	29.5
MRCCH-06-060	6	5.96	5.92	60	6.99	7	23.4	11.9	5.8	15	36.8	29.5
MRCCH-06-070	6	5.96	5.92	70	6.99	7	23.4	11.9	5.8	15	36.8	29.5
MRCCH-06-080	6	5.96	5.92	80	6.99	7	23.4	11.9	5.8	15	36.8	29.5
MRCCH-06-090	6	5.96	5.92	90	6.99	7	23.4	11.9	5.8	15	36.8	29.5
MRCCH-06-100	6	5.96	5.92	100	6.99	7	23.4	11.9	5.8	15	36.8	29.5
MRCCH-08-010	8	7.96	7.92	10	9.42	8	23.4	11.9	5.8	15	36.8	29.5
MRCCH-08-015	8	7.96	7.92	15	9.42	8	23.4	11.9	5.8	15	36.8	29.5
MRCCH-08-020	8	7.96	7.92	20	9.42	8	23.4	11.9	5.8	15	36.8	29.5
MRCCH-08-025	8	7.96	7.92	25	9.42	8	23.4	11.9	5.8	15	36.8	29.5
MRCCH-08-030	8	7.96	7.92	30	9.42	8	23.4	11.9	5.8	15	36.8	29.5
MRCCH-08-035	8	7.96	7.92	35	9.42	8	23.4	11.9	5.8	15	36.8	29.5
MRCCH-08-040	8	7.96	7.92	40	9.42	8	23.4	11.9	5.8	15	36.8	29.5
MRCCH-08-045	8	7.96	7.92	45	9.42	8	23.4	11.9	5.8	15	36.8	29.5
MRCCH-08-050	8	7.96	7.92	50	9.42	8	23.4	11.9	5.8	15	36.8	29.5
MRCCH-08-060	8	7.96	7.92	60	9.42	8	23.4	11.9	5.8	15	36.8	29.5
MRCCH-08-070	8	7.96	7.92	70	9.42	8	23.4	11.9	5.8	15	36.8	29.5
MRCCH-08-080	8	7.96	7.92	80	9.42	8	23.4	11.9	5.8	15	36.8	29.5
MRCCH-08-090	8	7.96	7.92	90	9.42	8	23.4	11.9	5.8	15	36.8	29.5
MRCCH-08-100	8	7.96	7.92	100	9.42	8	23.4	11.9	5.8	15	36.8	29.5



## QUICK RELEASE BALL LOCK PINS

### Stainless Steel Ring Handle | Metric (continued)

**MA** MODIFICATIONS AVAILABLE

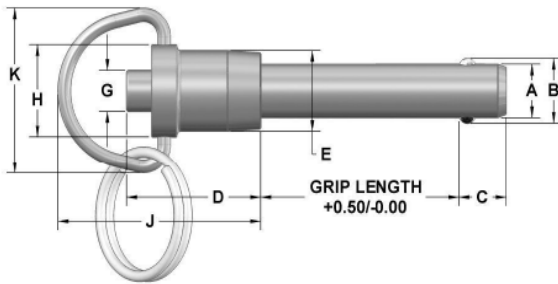

Dia mm	Hole Size Max mm	Min mm	Mn. Pull-Out Strength (N)	Calculated Double Shear (N) 17-4 Stainless
5	5.1	5.0	890	24,400
6	6.1	6.0	1,023	35,640
8	8.1	8.0	2,268	63,804
10	10.1	10.0	2,558	100,101
12	12.1	12.0	5,160	144,060
16	16.1	16.0	9,207	257,179

17-4 SS Part #	Nominal Diameter mm	A Max mm	A Min mm	Grip Length mm	+/-0.25 B mm	+/-1.0 C mm	D mm	E mm	G mm	H mm	J mm	K mm
MRCCH-10-015	10	9.96	9.92	15	11.86	9	25.7	14.2	7.4	16.5	38.6	29.5
MRCCH-10-020	10	9.96	9.92	20	11.86	9	25.7	14.2	7.4	16.5	38.6	29.5
MRCCH-10-025	10	9.96	9.92	25	11.86	9	25.7	14.2	7.4	16.5	38.6	29.5
MRCCH-10-030	10	9.96	9.92	30	11.86	9	25.7	14.2	7.4	16.5	38.6	29.5
MRCCH-10-035	10	9.96	9.92	35	11.86	9	25.7	14.2	7.4	16.5	38.6	29.5
MRCCH-10-040	10	9.96	9.92	40	11.86	9	25.7	14.2	7.4	16.5	38.6	29.5
MRCCH-10-045	10	9.96	9.92	45	11.86	9	25.7	14.2	7.4	16.5	38.6	29.5
MRCCH-10-050	10	9.96	9.92	50	11.86	9	25.7	14.2	7.4	16.5	38.6	29.5
MRCCH-10-060	10	9.96	9.92	60	11.86	9	25.7	14.2	7.4	16.5	38.6	29.5
MRCCH-10-070	10	9.96	9.92	70	11.86	9	25.7	14.2	7.4	16.5	38.6	29.5
MRCCH-10-080	10	9.96	9.92	80	11.86	9	25.7	14.2	7.4	16.5	38.6	29.5
MRCCH-10-090	10	9.96	9.92	90	11.86	9	25.7	14.2	7.4	16.5	38.6	29.5
MRCCH-10-100	10	9.96	9.92	100	11.86	9	25.7	14.2	7.4	16.5	38.6	29.5
MRCCH-12-020	12	11.96	11.92	20	14.45	10	32.3	18.3	10.7	20.6	47.8	36.3
MRCCH-12-025	12	11.96	11.92	25	14.45	10	32.3	18.3	10.7	20.6	47.8	36.3
MRCCH-12-030	12	11.96	11.92	30	14.45	10	32.3	18.3	10.7	20.6	47.8	36.3
MRCCH-12-035	12	11.96	11.92	35	14.45	10	32.3	18.3	10.7	20.6	47.8	36.3
MRCCH-12-040	12	11.96	11.92	40	14.45	10	32.3	18.3	10.7	20.6	47.8	36.3
MRCCH-12-045	12	11.96	11.92	45	14.45	10	32.3	18.3	10.7	20.6	47.8	36.3
MRCCH-12-050	12	11.96	11.92	50	14.45	10	32.3	18.3	10.7	20.6	47.8	36.3
MRCCH-12-060	12	11.96	11.92	60	14.45	10	32.3	18.3	10.7	20.6	47.8	36.3
MRCCH-12-070	12	11.96	11.92	70	14.45	10	32.3	18.3	10.7	20.6	47.8	36.3
MRCCH-12-080	12	11.96	11.92	80	14.45	10	32.3	18.3	10.7	20.6	47.8	36.3
MRCCH-12-090	12	11.96	11.92	90	14.45	10	32.3	18.3	10.7	20.6	47.8	36.3
MRCCH-12-100	12	11.96	11.92	100	14.45	10	32.3	18.3	10.7	20.6	47.8	36.3
MRCCH-16-025	16	15.96	15.92	25	19	14	41.9	23.9	13.7	26.9	65.3	43.7
MRCCH-16-030	16	15.96	15.92	30	19	14	41.9	23.9	13.7	26.9	65.3	43.7
MRCCH-16-035	16	15.96	15.92	35	19	14	41.9	23.9	13.7	26.9	65.3	43.7
MRCCH-16-040	16	15.96	15.92	40	19	14	41.9	23.9	13.7	26.9	65.3	43.7
MRCCH-16-045	16	15.96	15.92	45	19	14	41.9	23.9	13.7	26.9	65.3	43.7
MRCCH-16-050	16	15.96	15.92	50	19	14	41.9	23.9	13.7	26.9	65.3	43.7
MRCCH-16-060	16	15.96	15.92	60	19	14	41.9	23.9	13.7	26.9	65.3	43.7
MRCCH-16-070	16	15.96	15.92	70	19	14	41.9	23.9	13.7	26.9	65.3	43.7
MRCCH-16-080	16	15.96	15.92	80	19	14	41.9	23.9	13.7	26.9	65.3	43.7
MRCCH-16-090	16	15.96	15.92	90	19	14	41.9	23.9	13.7	26.9	65.3	43.7
MRCCH-16-100	16	15.96	15.92	100	19	14	41.9	23.9	13.7	26.9	65.3	43.7

## QUICK RELEASE BALL LOCK PINS

### Stainless Steel Nautical Recessed Handle | Inch

**MA** MODIFICATIONS AVAILABLE

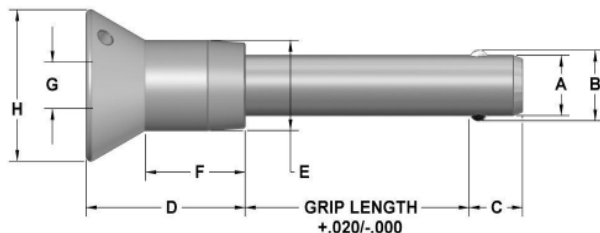

Dia	Hole Size		Min. Pull-Out Strength (lbs)	Calculated Double Shear (lbs)	
	Max	Min		17-4 Stainless	300 Series SS*
3/16	.1940	.1900	200	5,150	—
1/4	.2540	.2500	230	9,200	2,200
5/16	.3165	.3125	510	14,400	3,500
3/8	.3790	.3750	575	20,600	4,500
1/2	.5050	.5000	1,160	36,800	11,500
5/8	.6300	.6250	2,070	57,500	—

\*Note: 300 Series Stainless is not recommended in applications where shear forces are a factor.

These positive locking quick release pins have a wide range of uses in fastening, locating, and alignment applications. The pins will not release until the button on the handle is depressed. Once the button is depressed, the balls retract into the shank allowing the pin to be inserted or removed into or out of a hole. They are available in two stainless shank materials to meet your application. The handles are designed to prevent accidental release and are machined from 303 stainless steel. These pins are not supplied with stainless steel split rings. For specific application requirements, custom modifications are available for this product line. See page 3 for complete specifications. If a lanyard is ordered with the recessed handle, the lanyard will be attached directly to the pin without a split ring.

17-4 SS Part #	300 Series SS Part #	Nominal Diameter	A Max	A Min	Grip Length	+/- .005 B	+ .000/- .030 C	D	E	F	Button G	H
NCCH-18-050	—	3/16	.1885	.1870	.50	.220	.260	.97	.47	.64	.23	.81
NCCH-18-075	—	3/16	.1885	.1870	.75	.220	.260	.97	.47	.64	.23	.81
NCCH-18-100	—	3/16	.1885	.1870	1.00	.220	.260	.97	.47	.64	.23	.81
NCCH-18-125	—	3/16	.1885	.1870	1.25	.220	.260	.97	.47	.64	.23	.81
NCCH-18-150	—	3/16	.1885	.1870	1.50	.220	.260	.97	.47	.64	.23	.81
NCCH-18-175	—	3/16	.1885	.1870	1.75	.220	.260	.97	.47	.64	.23	.81
NCCH-18-200	—	3/16	.1885	.1870	2.00	.220	.260	.97	.47	.64	.23	.81
NCCH-18-250	—	3/16	.1885	.1870	2.50	.220	.260	.97	.47	.64	.23	.81
NCCH-18-300	—	3/16	.1885	.1870	3.00	.220	.260	.97	.47	.64	.23	.81
NCCH-18-350	—	3/16	.1885	.1870	3.50	.220	.260	.97	.47	.64	.23	.81
NCCH-18-400	—	3/16	.1885	.1870	4.00	.220	.260	.97	.47	.64	.23	.81
NCCH-25-050	NCCS-25-050	1/4	.2485	.2470	.50	.289	.290	.97	.47	.64	.23	.81
NCCH-25-075	NCCS-25-075	1/4	.2485	.2470	.75	.289	.290	.97	.47	.64	.23	.81
NCCH-25-100	NCCS-25-100	1/4	.2485	.2470	1.00	.289	.290	.97	.47	.64	.23	.81
NCCH-25-125	NCCS-25-125	1/4	.2485	.2470	1.25	.289	.290	.97	.47	.64	.23	.81
NCCH-25-150	NCCS-25-150	1/4	.2485	.2470	1.50	.289	.290	.97	.47	.64	.23	.81
NCCH-25-175	NCCS-25-175	1/4	.2485	.2470	1.75	.289	.290	.97	.47	.64	.23	.81
NCCH-25-200	NCCS-25-200	1/4	.2485	.2470	2.00	.289	.290	.97	.47	.64	.23	.81
NCCH-25-250	NCCS-25-250	1/4	.2485	.2470	2.50	.289	.290	.97	.47	.64	.23	.81
NCCH-25-300	NCCS-25-300	1/4	.2485	.2470	3.00	.289	.290	.97	.47	.64	.23	.81
NCCH-25-350	NCCS-25-350	1/4	.2485	.2470	3.50	.289	.290	.97	.47	.64	.23	.81
NCCH-25-400	NCCS-25-400	1/4	.2485	.2470	4.00	.289	.290	.97	.47	.64	.23	.81
NCCH-31-050	NCCS-31-050	5/16	.3110	.3095	.50	.375	.330	.97	.47	.64	.23	.81
NCCH-31-075	NCCS-31-075	5/16	.3110	.3095	.75	.375	.330	.97	.47	.64	.23	.81
NCCH-31-100	NCCS-31-100	5/16	.3110	.3095	1.00	.375	.330	.97	.47	.64	.23	.81
NCCH-31-125	NCCS-31-125	5/16	.3110	.3095	1.25	.375	.330	.97	.47	.64	.23	.81
NCCH-31-150	NCCS-31-150	5/16	.3110	.3095	1.50	.375	.330	.97	.47	.64	.23	.81
NCCH-31-175	NCCS-31-175	5/16	.3110	.3095	1.75	.375	.330	.97	.47	.64	.23	.81
NCCH-31-200	NCCS-31-200	5/16	.3110	.3095	2.00	.375	.330	.97	.47	.64	.23	.81
NCCH-31-250	NCCS-31-250	5/16	.3110	.3095	2.50	.375	.330	.97	.47	.64	.23	.81
NCCH-31-300	NCCS-31-300	5/16	.3110	.3095	3.00	.375	.330	.97	.47	.64	.23	.81
NCCH-31-350	NCCS-31-350	5/16	.3110	.3095	3.50	.375	.330	.97	.47	.64	.23	.81
NCCH-31-400	NCCS-31-400	5/16	.3110	.3095	4.00	.375	.330	.97	.47	.64	.23	.81



## QUICK RELEASE BALL LOCK PINS

### Stainless Steel Nautical Recessed Handle | Inch (continued)

**MA** MODIFICATIONS AVAILABLE

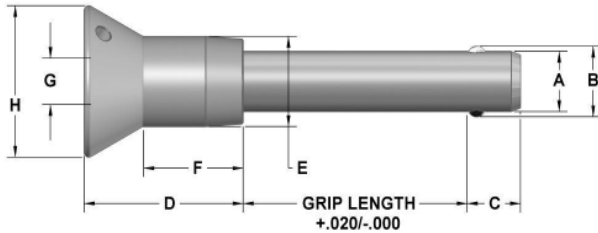

Dia	Hole Size		Min. Pull-Out Strength (lbs)	Calculated Double Shear (lbs)	
	Max	Min		17-4 Stainless	300 Series SS*
3/16	.1940	.1900	200	5,150	—
1/4	.2540	.2500	230	9,200	2,200
5/16	.3165	.3125	510	14,400	3,500
3/8	.3790	.3750	575	20,600	4,500
1/2	.5050	.5000	1,160	36,800	11,500
5/8	.6300	.6250	2,070	57,500	—

\*Note: 300 Series Stainless is not recommended in applications where shear forces are a factor.

17-4 SS Part#	300 Series SS Part#	Nominal Diameter	A Max	A Min	Grip Length	+/- .005 B	+ .000/- .030 C	D	E	F	Button G	H
NCCH-37-050	NCCS-37-050	3/8	.3735	.3720	.50	.440	.365	1.06	.56	.66	.29	.94
NCCH-37-075	NCCS-37-075	3/8	.3735	.3720	.75	.440	.365	1.06	.56	.66	.29	.94
NCCH-37-100	NCCS-37-100	3/8	.3735	.3720	1.00	.440	.365	1.06	.56	.66	.29	.94
NCCH-37-125	NCCS-37-125	3/8	.3735	.3720	1.25	.440	.365	1.06	.56	.66	.29	.94
NCCH-37-150	NCCS-37-150	3/8	.3735	.3720	1.50	.440	.365	1.06	.56	.66	.29	.94
NCCH-37-175	NCCS-37-175	3/8	.3735	.3720	1.75	.440	.365	1.06	.56	.66	.29	.94
NCCH-37-200	NCCS-37-200	3/8	.3735	.3720	2.00	.440	.365	1.06	.56	.66	.29	.94
NCCH-37-250	NCCS-37-250	3/8	.3735	.3720	2.50	.440	.365	1.06	.56	.66	.29	.94
NCCH-37-300	NCCS-37-300	3/8	.3735	.3720	3.00	.440	.365	1.06	.56	.66	.29	.94
NCCH-37-350	NCCS-37-350	3/8	.3735	.3720	3.50	.440	.365	1.06	.56	.66	.29	.94
NCCH-37-400	NCCS-37-400	3/8	.3735	.3720	4.00	.440	.365	1.06	.56	.66	.29	.94
NCCH-50-100	NCCS-50-100	1/2	.4985	.4970	1.00	.594	.460	1.31	.72	.89	.42	1.12
NCCH-50-125	NCCS-50-125	1/2	.4985	.4970	1.25	.594	.460	1.31	.72	.89	.42	1.12
NCCH-50-150	NCCS-50-150	1/2	.4985	.4970	1.50	.594	.460	1.31	.72	.89	.42	1.12
NCCH-50-175	NCCS-50-175	1/2	.4985	.4970	1.75	.594	.460	1.31	.72	.89	.42	1.12
NCCH-50-200	NCCS-50-200	1/2	.4985	.4970	2.00	.594	.460	1.31	.72	.89	.42	1.12
NCCH-50-250	NCCS-50-250	1/2	.4985	.4970	2.50	.594	.460	1.31	.72	.89	.42	1.12
NCCH-50-300	NCCS-50-300	1/2	.4985	.4970	3.00	.594	.460	1.31	.72	.89	.42	1.12
NCCH-50-350	NCCS-50-350	1/2	.4985	.4970	3.50	.594	.460	1.31	.72	.89	.42	1.12
NCCH-50-400	NCCS-50-400	1/2	.4985	.4970	4.00	.594	.460	1.31	.72	.89	.42	1.12
NCCH-50-450	NCCS-50-450	1/2	.4985	.4970	4.50	.594	.460	1.31	.72	.89	.42	1.12
NCCH-50-500	NCCS-50-500	1/2	.4985	.4970	5.00	.594	.460	1.31	.72	.89	.42	1.12
NCCH-50-550	NCCS-50-550	1/2	.4985	.4970	5.50	.594	.460	1.31	.72	.89	.42	1.12
NCCH-50-600	NCCS-50-600	1/2	.4985	.4970	6.00	.594	.460	1.31	.72	.89	.42	1.12
NCCH-62-150	—	5/8	.6235	.6220	1.50	.750	.580	1.69	.94	1.12	.54	1.44
NCCH-62-175	—	5/8	.6235	.6220	1.75	.750	.580	1.69	.94	1.12	.54	1.44
NCCH-62-200	—	5/8	.6235	.6220	2.00	.750	.580	1.69	.94	1.12	.54	1.44
NCCH-62-250	—	5/8	.6235	.6220	2.50	.750	.580	1.69	.94	1.12	.54	1.44
NCCH-62-300	—	5/8	.6235	.6220	3.00	.750	.580	1.69	.94	1.12	.54	1.44
NCCH-62-350	—	5/8	.6235	.6220	3.50	.750	.580	1.69	.94	1.12	.54	1.44
NCCH-62-400	—	5/8	.6235	.6220	4.00	.750	.580	1.69	.94	1.12	.54	1.44
NCCH-62-450	—	5/8	.6235	.6220	4.50	.750	.580	1.69	.94	1.12	.54	1.44
NCCH-62-500	—	5/8	.6235	.6220	5.00	.750	.580	1.69	.94	1.12	.54	1.44
NCCH-62-550	—	5/8	.6235	.6220	5.50	.750	.580	1.69	.94	1.12	.54	1.44
NCCH-62-600	—	5/8	.6235	.6220	6.00	.750	.580	1.69	.94	1.12	.54	1.44

# QUICK RELEASE BALL LOCK PINS

## Stainless Steel Nautical Recessed Handle | Metric

**MA** MODIFICATIONS AVAILABLE

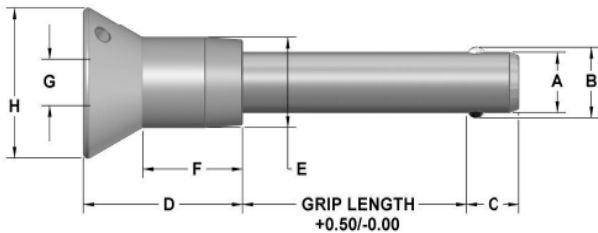

Dia mm	Hole Size Max mm	Hole Size Min mm	Min. Pull-Out Strength (N)	Calculated Double Shear (N) 17-4 Stainless
5	5.1	5.0	890	24,400
6	6.1	6.0	1,023	35,640
8	8.1	8.0	2,268	63,804
10	10.1	10.0	2,558	100,101
12	12.1	12.0	5,160	144,060
16	16.1	16.0	9,207	257,179

These positive locking quick release pins have a wide range of uses in fastening, locating, and alignment applications. The pins will not release until the button on the handle is depressed. Once the button is depressed, the balls retract into the shank allowing the pin to be inserted or removed into or out of a hole. The handles are designed to prevent accidental release and are machined from 303 stainless steel. The shafts are made from 17-4PH stainless steel. These pins are not supplied with stainless steel split rings. For specific application requirements, custom modifications are available for this product line. See page 3 for complete specifications. RoHS compliant. If a lanyard is ordered with the recessed handle, the lanyard will be attached directly to the pin without a split ring.

17-4 SS Part #	Nominal Diameter mm	A Max mm	A Min mm	Grip Length mm	+/-0.25 B mm	+/-1.0 C mm	D mm	E mm	F mm	Button G mm	H mm
MNCCH-05-010	5	4.96	4.92	10	5.54	6	24.6	11.9	16.3	5.8	20.6
MNCCH-05-015	5	4.96	4.92	15	5.54	6	24.6	11.9	16.3	5.8	20.6
MNCCH-05-020	5	4.96	4.92	20	5.54	6	24.6	11.9	16.3	5.8	20.6
MNCCH-05-025	5	4.96	4.92	25	5.54	6	24.6	11.9	16.3	5.8	20.6
MNCCH-05-030	5	4.96	4.92	30	5.54	6	24.6	11.9	16.3	5.8	20.6
MNCCH-05-035	5	4.96	4.92	35	5.54	6	24.6	11.9	16.3	5.8	20.6
MNCCH-05-040	5	4.96	4.92	40	5.54	6	24.6	11.9	16.3	5.8	20.6
MNCCH-05-045	5	4.96	4.92	45	5.54	6	24.6	11.9	16.3	5.8	20.6
MNCCH-05-050	5	4.96	4.92	50	5.54	6	24.6	11.9	16.3	5.8	20.6
MNCCH-05-060	5	4.96	4.92	60	5.54	6	24.6	11.9	16.3	5.8	20.6
MNCCH-05-070	5	4.96	4.92	70	5.54	6	24.6	11.9	16.3	5.8	20.6
MNCCH-05-080	5	4.96	4.92	80	5.54	6	24.6	11.9	16.3	5.8	20.6
MNCCH-05-090	5	4.96	4.92	90	5.54	6	24.6	11.9	16.3	5.8	20.6
MNCCH-05-100	5	4.96	4.92	100	5.54	6	24.6	11.9	16.3	5.8	20.6
MNCCH-06-010	6	5.96	5.92	10	6.99	7	24.6	11.9	16.3	5.8	20.6
MNCCH-06-015	6	5.96	5.92	15	6.99	7	24.6	11.9	16.3	5.8	20.6
MNCCH-06-020	6	5.96	5.92	20	6.99	7	24.6	11.9	16.3	5.8	20.6
MNCCH-06-025	6	5.96	5.92	25	6.99	7	24.6	11.9	16.3	5.8	20.6
MNCCH-06-030	6	5.96	5.92	30	6.99	7	24.6	11.9	16.3	5.8	20.6
MNCCH-06-035	6	5.96	5.92	35	6.99	7	24.6	11.9	16.3	5.8	20.6
MNCCH-06-040	6	5.96	5.92	40	6.99	7	24.6	11.9	16.3	5.8	20.6
MNCCH-06-045	6	5.96	5.92	45	6.99	7	24.6	11.9	16.3	5.8	20.6
MNCCH-06-050	6	5.96	5.92	50	6.99	7	24.6	11.9	16.3	5.8	20.6
MNCCH-06-060	6	5.96	5.92	60	6.99	7	24.6	11.9	16.3	5.8	20.6
MNCCH-06-070	6	5.96	5.92	70	6.99	7	24.6	11.9	16.3	5.8	20.6
MNCCH-06-080	6	5.96	5.92	80	6.99	7	24.6	11.9	16.3	5.8	20.6
MNCCH-06-090	6	5.96	5.92	90	6.99	7	24.6	11.9	16.3	5.8	20.6
MNCCH-06-100	6	5.96	5.92	100	6.99	7	24.6	11.9	16.3	5.8	20.6
MNCCH-08-010	8	7.96	7.92	10	9.42	8	24.6	11.9	16.3	5.8	20.6
MNCCH-08-015	8	7.96	7.92	15	9.42	8	24.6	11.9	16.3	5.8	20.6
MNCCH-08-020	8	7.96	7.92	20	9.42	8	24.6	11.9	16.3	5.8	20.6
MNCCH-08-025	8	7.96	7.92	25	9.42	8	24.6	11.9	16.3	5.8	20.6
MNCCH-08-030	8	7.96	7.92	30	9.42	8	24.6	11.9	16.3	5.8	20.6
MNCCH-08-035	8	7.96	7.92	35	9.42	8	24.6	11.9	16.3	5.8	20.6
MNCCH-08-040	8	7.96	7.92	40	9.42	8	24.6	11.9	16.3	5.8	20.6
MNCCH-08-045	8	7.96	7.92	45	9.42	8	24.6	11.9	16.3	5.8	20.6
MNCCH-08-050	8	7.96	7.92	50	9.42	8	24.6	11.9	16.3	5.8	20.6
MNCCH-08-060	8	7.96	7.92	60	9.42	8	24.6	11.9	16.3	5.8	20.6
MNCCH-08-070	8	7.96	7.92	70	9.42	8	24.6	11.9	16.3	5.8	20.6
MNCCH-08-080	8	7.96	7.92	80	9.42	8	24.6	11.9	16.3	5.8	20.6
MNCCH-08-090	8	7.96	7.92	90	9.42	8	24.6	11.9	16.3	5.8	20.6
MNCCH-08-100	8	7.96	7.92	100	9.42	8	24.6	11.9	16.3	5.8	20.6



## QUICK RELEASE BALL LOCK PINS

### Stainless Steel Nautical Recessed Handle | Metric (continued)

**MA** MODIFICATIONS AVAILABLE

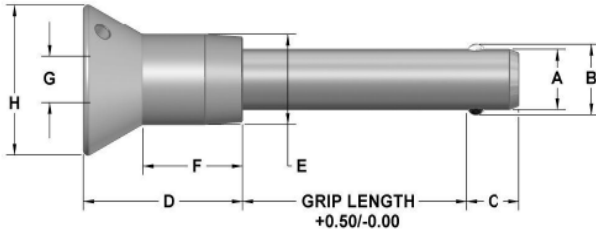

Dia mm	Hole Size Max mm	Min mm	Min. Pull-Out Strength (N)	Calculated Double Shear (N) 17-4 Stainless
5	5.1	5.0	890	24,400
6	6.1	6.0	1,023	35,640
8	8.1	8.0	2,268	63,804
10	10.1	10.0	2,558	100,101
12	12.1	12.0	5,160	144,060
16	16.1	16.0	9,207	257,179

17-4 SS Part #	Nominal Diameter mm	A Max mm	A Min mm	Grip Length mm	+/-0.25 B mm	+/-1.0 C mm	D mm	E mm	F mm	Button G mm	H mm
MNCCH-10-015	10	9.96	9.92	15	11.86	9	26.9	14.2	16.8	7.4	23.9
MNCCH-10-020	10	9.96	9.92	20	11.86	9	26.9	14.2	16.8	7.4	23.9
MNCCH-10-025	10	9.96	9.92	25	11.86	9	26.9	14.2	16.8	7.4	23.9
MNCCH-10-030	10	9.96	9.92	30	11.86	9	26.9	14.2	16.8	7.4	23.9
MNCCH-10-035	10	9.96	9.92	35	11.86	9	26.9	14.2	16.8	7.4	23.9
MNCCH-10-040	10	9.96	9.92	40	11.86	9	26.9	14.2	16.8	7.4	23.9
MNCCH-10-045	10	9.96	9.92	45	11.86	9	26.9	14.2	16.8	7.4	23.9
MNCCH-10-050	10	9.96	9.92	50	11.86	9	26.9	14.2	16.8	7.4	23.9
MNCCH-10-060	10	9.96	9.92	60	11.86	9	26.9	14.2	16.8	7.4	23.9
MNCCH-10-070	10	9.96	9.92	70	11.86	9	26.9	14.2	16.8	7.4	23.9
MNCCH-10-080	10	9.96	9.92	80	11.86	9	26.9	14.2	16.8	7.4	23.9
MNCCH-10-090	10	9.96	9.92	90	11.86	9	26.9	14.2	16.8	7.4	23.9
MNCCH-10-100	10	9.96	9.92	100	11.86	9	26.9	14.2	16.8	7.4	23.9
MNCCH-12-020	12	11.96	11.92	20	14.45	10	33.3	18.3	22.6	10.7	28.4
MNCCH-12-025	12	11.96	11.92	25	14.45	10	33.3	18.3	22.6	10.7	28.4
MNCCH-12-030	12	11.96	11.92	30	14.45	10	33.3	18.3	22.6	10.7	28.4
MNCCH-12-035	12	11.96	11.92	35	14.45	10	33.3	18.3	22.6	10.7	28.4
MNCCH-12-040	12	11.96	11.92	40	14.45	10	33.3	18.3	22.6	10.7	28.4
MNCCH-12-045	12	11.96	11.92	45	14.45	10	33.3	18.3	22.6	10.7	28.4
MNCCH-12-050	12	11.96	11.92	50	14.45	10	33.3	18.3	22.6	10.7	28.4
MNCCH-12-060	12	11.96	11.92	60	14.45	10	33.3	18.3	22.6	10.7	28.4
MNCCH-12-070	12	11.96	11.92	70	14.45	10	33.3	18.3	22.6	10.7	28.4
MNCCH-12-080	12	11.96	11.92	80	14.45	10	33.3	18.3	22.6	10.7	28.4
MNCCH-12-090	12	11.96	11.92	90	14.45	10	33.3	18.3	22.6	10.7	28.4
MNCCH-12-100	12	11.96	11.92	100	14.45	10	33.3	18.3	22.6	10.7	28.4
MNCCH-16-025	16	15.96	15.92	25	19	14	42.9	23.8	28.5	13.7	36.5
MNCCH-16-030	16	15.96	15.92	30	19	14	42.9	23.8	28.5	13.7	36.5
MNCCH-16-035	16	15.96	15.92	35	19	14	42.9	23.8	28.5	13.7	36.5
MNCCH-16-040	16	15.96	15.92	40	19	14	42.9	23.8	28.5	13.7	36.5
MNCCH-16-045	16	15.96	15.92	45	19	14	42.9	23.8	28.5	13.7	36.5
MNCCH-16-050	16	15.96	15.92	50	19	14	42.9	23.8	28.5	13.7	36.5
MNCCH-16-060	16	15.96	15.92	60	19	14	42.9	23.8	28.5	13.7	36.5
MNCCH-16-070	16	15.96	15.92	70	19	14	42.9	23.8	28.5	13.7	36.5
MNCCH-16-080	16	15.96	15.92	80	19	14	42.9	23.8	28.5	13.7	36.5
MNCCH-16-090	16	15.96	15.92	90	19	14	42.9	23.8	28.5	13.7	36.5
MNCCH-16-100	16	15.96	15.92	100	19	14	42.9	23.8	28.5	13.7	36.5

# QUICK RELEASE BALL LOCK PINS

## Aluminum Dome Handle | Inch

**MA** MODIFICATIONS AVAILABLE

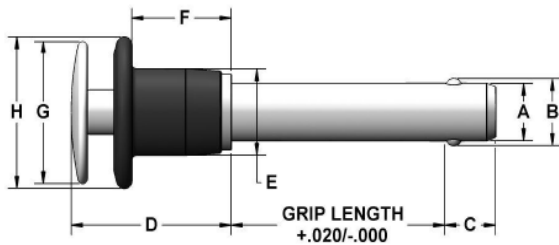

Dia	Hole Size		Min. Pull-Out Strength (lbs)	Calculated Double Shear (lbs)		
	Max	Min		4130 Steel	17-4 Stainless	300 Series SS*
3/16	.1940	.1900	200	4,600	5,150	—
1/4	.2540	.2500	230	8,200	9,200	2,200
5/16	.3165	.3125	510	12,800	14,400	3,500
3/8	.3790	.3750	575	18,400	20,600	4,500
1/2	.5050	.5000	1,160	32,800	36,800	11,500
5/8	.6300	.6250	2,070	51,200	57,500	—

\*Note: 300 Series Stainless is not recommended in applications where shear forces are a factor.

These positive locking quick release pins have a wide range of uses in fastening, locating, and alignment applications. The pins will not release until the button on the handle is depressed. Once the button is depressed, the balls retract into the shank allowing the pin to be inserted or removed into or out of a hole. They are available in three shank materials to meet your application. The dome actuator buttons are made from 2024-T4 aluminum and clear anodized. The handles are made from 2024-T4 aluminum and anodized black. Handle has hole for optional wire lanyard attachment. The large ergonomic dome actuator button facilitates easy installation and removal of the pin. They are ideal in applications where there is repetitive or frequent use of the pin. In addition, they can be used in situations where the operator is wearing gloves or has limited range of hand motion. They also add a unique look and feel that is not available with other pin styles and offer a large area for engraving or stamping to add logos, instructions, etc. For specific application requirements, custom modifications are available for this product line. See page 3 for complete specifications.

4130 Steel Part#	17-4 SS Part#	300 Series SS Part#	Nominal Diameter	A Max	A Min	Grip Length	+/- .005 B	+ .000/- .030 C	D	E	F	G	H
DAAS-18-050	DACH-18-050	—	3/16	.1885	.1870	.50	.220	.260	1.00	.47	.63	.75	.81
DAAS-18-075	DACH-18-075	—	3/16	.1885	.1870	.75	.220	.260	1.00	.47	.63	.75	.81
DAAS-18-100	DACH-18-100	—	3/16	.1885	.1870	1.00	.220	.260	1.00	.47	.63	.75	.81
DAAS-18-125	DACH-18-125	—	3/16	.1885	.1870	1.25	.220	.260	1.00	.47	.63	.75	.81
DAAS-18-150	DACH-18-150	—	3/16	.1885	.1870	1.50	.220	.260	1.00	.47	.63	.75	.81
DAAS-18-175	DACH-18-175	—	3/16	.1885	.1870	1.75	.220	.260	1.00	.47	.63	.75	.81
DAAS-18-200	DACH-18-200	—	3/16	.1885	.1870	2.00	.220	.260	1.00	.47	.63	.75	.81
DAAS-18-250	DACH-18-250	—	3/16	.1885	.1870	2.50	.220	.260	1.00	.47	.63	.75	.81
DAAS-18-300	DACH-18-300	—	3/16	.1885	.1870	3.00	.220	.260	1.00	.47	.63	.75	.81
DAAS-18-350	DACH-18-350	—	3/16	.1885	.1870	3.50	.220	.260	1.00	.47	.63	.75	.81
DAAS-18-400	DACH-18-400	—	3/16	.1885	.1870	4.00	.220	.260	1.00	.47	.63	.75	.81
DAAS-25-050	DACH-25-050	DACS-25-050	1/4	.2485	.2470	.50	.289	.290	1.00	.47	.63	.75	.81
DAAS-25-075	DACH-25-075	DACS-25-075	1/4	.2485	.2470	.75	.289	.290	1.00	.47	.63	.75	.81
DAAS-25-100	DACH-25-100	DACS-25-100	1/4	.2485	.2470	1.00	.289	.290	1.00	.47	.63	.75	.81
DAAS-25-125	DACH-25-125	DACS-25-125	1/4	.2485	.2470	1.25	.289	.290	1.00	.47	.63	.75	.81
DAAS-25-150	DACH-25-150	DACS-25-150	1/4	.2485	.2470	1.50	.289	.290	1.00	.47	.63	.75	.81
DAAS-25-175	DACH-25-175	DACS-25-175	1/4	.2485	.2470	1.75	.289	.290	1.00	.47	.63	.75	.81
DAAS-25-200	DACH-25-200	DACS-25-200	1/4	.2485	.2470	2.00	.289	.290	1.00	.47	.63	.75	.81
DAAS-25-250	DACH-25-250	DACS-25-250	1/4	.2485	.2470	2.50	.289	.290	1.00	.47	.63	.75	.81
DAAS-25-300	DACH-25-300	DACS-25-300	1/4	.2485	.2470	3.00	.289	.290	1.00	.47	.63	.75	.81
DAAS-25-350	DACH-25-350	DACS-25-350	1/4	.2485	.2470	3.50	.289	.290	1.00	.47	.63	.75	.81
DAAS-25-400	DACH-25-400	DACS-25-400	1/4	.2485	.2470	4.00	.289	.290	1.00	.47	.63	.75	.81
DAAS-31-050	DACH-31-050	DACS-31-050	5/16	.3110	.3095	.50	.375	.330	1.00	.47	.63	.75	.81
DAAS-31-075	DACH-31-075	DACS-31-075	5/16	.3110	.3095	.75	.375	.330	1.00	.47	.63	.75	.81
DAAS-31-100	DACH-31-100	DACS-31-100	5/16	.3110	.3095	1.00	.375	.330	1.00	.47	.63	.75	.81
DAAS-31-125	DACH-31-125	DACS-31-125	5/16	.3110	.3095	1.25	.375	.330	1.00	.47	.63	.75	.81
DAAS-31-150	DACH-31-150	DACS-31-150	5/16	.3110	.3095	1.50	.375	.330	1.00	.47	.63	.75	.81
DAAS-31-175	DACH-31-175	DACS-31-175	5/16	.3110	.3095	1.75	.375	.330	1.00	.47	.63	.75	.81
DAAS-31-200	DACH-31-200	DACS-31-200	5/16	.3110	.3095	2.00	.375	.330	1.00	.47	.63	.75	.81
DAAS-31-250	DACH-31-250	DACS-31-250	5/16	.3110	.3095	2.50	.375	.330	1.00	.47	.63	.75	.81
DAAS-31-300	DACH-31-300	DACS-31-300	5/16	.3110	.3095	3.00	.375	.330	1.00	.47	.63	.75	.81
DAAS-31-350	DACH-31-350	DACS-31-350	5/16	.3110	.3095	3.50	.375	.330	1.00	.47	.63	.75	.81
DAAS-31-400	DACH-31-400	DACS-31-400	5/16	.3110	.3095	4.00	.375	.330	1.00	.47	.63	.75	.81



# QUICK RELEASE BALL LOCK PINS

## Aluminum Dome Handle | Inch (continued)

**MA** MODIFICATIONS AVAILABLE

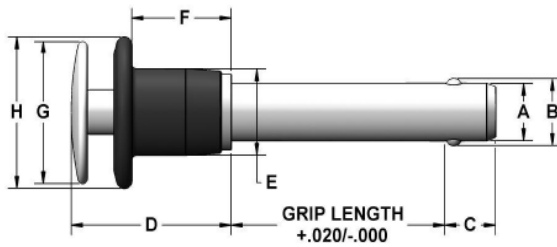

Dia	Hole Size		Min. Pull-Out Strength (lbs)	Calculated Double Shear (lbs)		
	Max	Min		4130 Steel	17-4 Stainless	300 Series SS*
3/16	.1940	.1900	200	4,600	5,150	—
1/4	.2540	.2500	230	8,200	9,200	2,200
5/16	.3165	.3125	510	12,800	14,400	3,500
3/8	.3790	.3750	575	18,400	20,600	4,500
1/2	.5050	.5000	1,160	32,800	36,800	11,500
5/8	.6300	.6250	2,070	51,200	57,500	—

\*Note: 300 Series Stainless is not recommended in applications where shear forces are a factor.

4130 Steel Part #	17-4 SS Part #	300 Series SS Part #	Nominal Diameter	A Max	A Min	Grip Length	+/- .005 B	+ .000/- .030 C	D	E	F	G	H
DAAS-37-050	DACH-37-050	DACS-37-050	3/8	.3735	.3720	.50	.440	.365	1.12	.56	.70	.932	1.00
DAAS-37-075	DACH-37-075	DACS-37-075	3/8	.3735	.3720	.75	.440	.365	1.12	.56	.70	.932	1.00
DAAS-37-100	DACH-37-100	DACS-37-100	3/8	.3735	.3720	1.00	.440	.365	1.12	.56	.70	.932	1.00
DAAS-37-125	DACH-37-125	DACS-37-125	3/8	.3735	.3720	1.25	.440	.365	1.12	.56	.70	.932	1.00
DAAS-37-150	DACH-37-150	DACS-37-150	3/8	.3735	.3720	1.50	.440	.365	1.12	.56	.70	.932	1.00
DAAS-37-175	DACH-37-175	DACS-37-175	3/8	.3735	.3720	1.75	.440	.365	1.12	.56	.70	.932	1.00
DAAS-37-200	DACH-37-200	DACS-37-200	3/8	.3735	.3720	2.00	.440	.365	1.12	.56	.70	.932	1.00
DAAS-37-250	DACH-37-250	DACS-37-250	3/8	.3735	.3720	2.50	.440	.365	1.12	.56	.70	.932	1.00
DAAS-37-300	DACH-37-300	DACS-37-300	3/8	.3735	.3720	3.00	.440	.365	1.12	.56	.70	.932	1.00
DAAS-37-350	DACH-37-350	DACS-37-350	3/8	.3735	.3720	3.50	.440	.365	1.12	.56	.70	.932	1.00
DAAS-37-400	DACH-37-400	DACS-37-400	3/8	.3735	.3720	4.00	.440	.365	1.12	.56	.70	.932	1.00
DAAS-50-100	DACH-50-100	DACS-50-100	1/2	.4985	.4970	1.00	.594	.460	1.41	.72	.85	1.30	1.37
DAAS-50-125	DACH-50-125	DACS-50-125	1/2	.4985	.4970	1.25	.594	.460	1.41	.72	.85	1.30	1.37
DAAS-50-150	DACH-50-150	DACS-50-150	1/2	.4985	.4970	1.50	.594	.460	1.41	.72	.85	1.30	1.37
DAAS-50-175	DACH-50-175	DACS-50-175	1/2	.4985	.4970	1.75	.594	.460	1.41	.72	.85	1.30	1.37
DAAS-50-200	DACH-50-200	DACS-50-200	1/2	.4985	.4970	2.00	.594	.460	1.41	.72	.85	1.30	1.37
DAAS-50-250	DACH-50-250	DACS-50-250	1/2	.4985	.4970	2.50	.594	.460	1.41	.72	.85	1.30	1.37
DAAS-50-300	DACH-50-300	DACS-50-300	1/2	.4985	.4970	3.00	.594	.460	1.41	.72	.85	1.30	1.37
DAAS-50-350	DACH-50-350	DACS-50-350	1/2	.4985	.4970	3.50	.594	.460	1.41	.72	.85	1.30	1.37
DAAS-50-400	DACH-50-400	DACS-50-400	1/2	.4985	.4970	4.00	.594	.460	1.41	.72	.85	1.30	1.37
DAAS-50-450	DACH-50-450	DACS-50-450	1/2	.4985	.4970	4.50	.594	.460	1.41	.72	.85	1.30	1.37
DAAS-50-500	DACH-50-500	DACS-50-500	1/2	.4985	.4970	5.00	.594	.460	1.41	.72	.85	1.30	1.37
DAAS-50-550	DACH-50-550	DACS-50-550	1/2	.4985	.4970	5.50	.594	.460	1.41	.72	.85	1.30	1.37
DAAS-50-600	DACH-50-600	DACS-50-600	1/2	.4985	.4970	6.00	.594	.460	1.41	.72	.85	1.30	1.37
DAAS-62-150	DACH-62-150	—	5/8	.6235	.6220	1.50	.750	.580	1.84	.94	1.10	1.68	1.75
DAAS-62-175	DACH-62-175	—	5/8	.6235	.6220	1.75	.750	.580	1.84	.94	1.10	1.68	1.75
DAAS-62-200	DACH-62-200	—	5/8	.6235	.6220	2.00	.750	.580	1.84	.94	1.10	1.68	1.75
DAAS-62-250	DACH-62-250	—	5/8	.6235	.6220	2.50	.750	.580	1.84	.94	1.10	1.68	1.75
DAAS-62-300	DACH-62-300	—	5/8	.6235	.6220	3.00	.750	.580	1.84	.94	1.10	1.68	1.75
DAAS-62-350	DACH-62-350	—	5/8	.6235	.6220	3.50	.750	.580	1.84	.94	1.10	1.68	1.75
DAAS-62-400	DACH-62-400	—	5/8	.6235	.6220	4.00	.750	.580	1.84	.94	1.10	1.68	1.75
DAAS-62-450	DACH-62-450	—	5/8	.6235	.6220	4.50	.750	.580	1.84	.94	1.10	1.68	1.75
DAAS-62-500	DACH-62-500	—	5/8	.6235	.6220	5.00	.750	.580	1.84	.94	1.10	1.68	1.75
DAAS-62-550	DACH-62-550	—	5/8	.6235	.6220	5.50	.750	.580	1.84	.94	1.10	1.68	1.75
DAAS-62-600	DACH-62-600	—	5/8	.6235	.6220	6.00	.750	.580	1.84	.94	1.10	1.68	1.75

## QUICK RELEASE BALL LOCK PINS

### Aluminum Dome Handle | Metric

**MA** MODIFICATIONS AVAILABLE

**EXPANDED LINE**

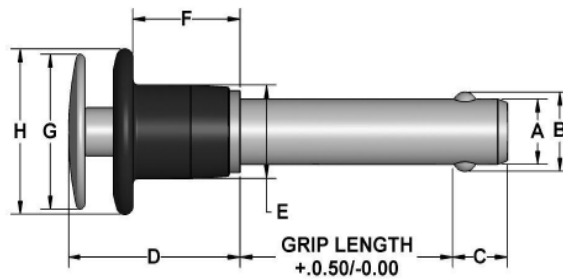

Dia mm	Hole Size mm		Min. Pull-Out Strength (N)	Calculated Double Shear (N)	
	Max	Min		4130 Steel	17-4 Stainless
5	5.1	5.0	890	21,600	24,400
6	6.1	6.0	1,023	31,686	35,640
8	8.1	8.0	2,268	56,712	63,804
10	10.1	10.0	2,558	88,977	100,101
12	12.1	12.0	5,160	128,050	144,060
16	16.1	16.0	9,207	228,602	257,179

These positive locking quick release pins have a wide range of uses in fastening, locating, and alignment applications. The pins will not release until the button on the handle is depressed. Once the button is depressed, the balls retract into the shank allowing the pin to be inserted or removed into or out of a hole. The shanks are available in 4130 steel with zinc plating or 17-4PH stainless steel. Handle has hole for optional wire lanyard attachment. The dome actuator buttons are made from 2024-T4 aluminum and clear anodized. The handles are made from 2024-T4 aluminum and anodized black. The large ergonomic dome actuator button facilitates easy installation and removal of the pin. They are ideal in applications where there is repetitive or frequent use of the pin. In addition, they can be used in situations where the operator is wearing gloves or has limited range of hand motion. They also add a unique look and feel that is not available with other pin styles and offer a large area for engraving or stamping to add logos, instructions, etc. For specific application requirements, custom modifications are available for this product line. See page 3 for complete specifications. RoHS compliant.

4130 Steel Part #	17-4 SS Part #	Nominal Diameter mm	A Max mm	A Min mm	Grip Length mm	+/-0.25 B mm	+/-1.0 C mm	D mm	E mm	F mm	G mm	H mm
MDAAS-05-010	MDACH-05-010	5	4.96	4.92	10	5.54	6	25.5	11.9	16	19	20.6
MDAAS-05-015	MDACH-05-015	5	4.96	4.92	15	5.54	6	25.5	11.9	16	19	20.6
MDAAS-05-020	MDACH-05-020	5	4.96	4.92	20	5.54	6	25.5	11.9	16	19	20.6
MDAAS-05-025	MDACH-05-025	5	4.96	4.92	25	5.54	6	25.5	11.9	16	19	20.6
MDAAS-05-030	MDACH-05-030	5	4.96	4.92	30	5.54	6	25.5	11.9	16	19	20.6
MDAAS-05-035	MDACH-05-035	5	4.96	4.92	35	5.54	6	25.5	11.9	16	19	20.6
MDAAS-05-040	MDACH-05-040	5	4.96	4.92	40	5.54	6	25.5	11.9	16	19	20.6
MDAAS-05-045	MDACH-05-045	5	4.96	4.92	45	5.54	6	25.5	11.9	16	19	20.6
MDAAS-05-050	MDACH-05-050	5	4.96	4.92	50	5.54	6	25.5	11.9	16	19	20.6
MDAAS-05-060	MDACH-05-060	5	4.96	4.92	60	5.54	6	25.5	11.9	16	19	20.6
MDAAS-05-070	MDACH-05-070	5	4.96	4.92	70	5.54	6	25.5	11.9	16	19	20.6
MDAAS-05-080	MDACH-05-080	5	4.96	4.92	80	5.54	6	25.5	11.9	16	19	20.6
MDAAS-05-090	MDACH-05-090	5	4.96	4.92	90	5.54	6	25.5	11.9	16	19	20.6
MDAAS-05-100	MDACH-05-100	5	4.96	4.92	100	5.54	6	25.5	11.9	16	19	20.6
MDAAS-06-010	MDACH-06-010	6	5.96	5.92	10	6.99	7	25.5	11.9	16	19	20.6
MDAAS-06-015	MDACH-06-015	6	5.96	5.92	15	6.99	7	25.5	11.9	16	19	20.6
MDAAS-06-020	MDACH-06-020	6	5.96	5.92	20	6.99	7	25.5	11.9	16	19	20.6
MDAAS-06-025	MDACH-06-025	6	5.96	5.92	25	6.99	7	25.5	11.9	16	19	20.6
MDAAS-06-030	MDACH-06-030	6	5.96	5.92	30	6.99	7	25.5	11.9	16	19	20.6
MDAAS-06-035	MDACH-06-035	6	5.96	5.92	35	6.99	7	25.5	11.9	16	19	20.6
MDAAS-06-040	MDACH-06-040	6	5.96	5.92	40	6.99	7	25.5	11.9	16	19	20.6
MDAAS-06-045	MDACH-06-045	6	5.96	5.92	45	6.99	7	25.5	11.9	16	19	20.6
MDAAS-06-050	MDACH-06-050	6	5.96	5.92	50	6.99	7	25.5	11.9	16	19	20.6
MDAAS-06-060	MDACH-06-060	6	5.96	5.92	60	6.99	7	25.5	11.9	16	19	20.6
MDAAS-06-070	MDACH-06-070	6	5.96	5.92	70	6.99	7	25.5	11.9	16	19	20.6
MDAAS-06-080	MDACH-06-080	6	5.96	5.92	80	6.99	7	25.5	11.9	16	19	20.6
MDAAS-06-090	MDACH-06-090	6	5.96	5.92	90	6.99	7	25.5	11.9	16	19	20.6
MDAAS-06-100	MDACH-06-100	6	5.96	5.92	100	6.99	7	25.5	11.9	16	19	20.6
MDAAS-08-010	MDACH-08-010	8	7.96	7.92	10	9.42	8	25.5	11.9	16	19	20.6
MDAAS-08-015	MDACH-08-015	8	7.96	7.92	15	9.42	8	25.5	11.9	16	19	20.6
MDAAS-08-020	MDACH-08-020	8	7.96	7.92	20	9.42	8	25.5	11.9	16	19	20.6
MDAAS-08-025	MDACH-08-025	8	7.96	7.92	25	9.42	8	25.5	11.9	16	19	20.6
MDAAS-08-030	MDACH-08-030	8	7.96	7.92	30	9.42	8	25.5	11.9	16	19	20.6
MDAAS-08-035	MDACH-08-035	8	7.96	7.92	35	9.42	8	25.5	11.9	16	19	20.6
MDAAS-08-040	MDACH-08-040	8	7.96	7.92	40	9.42	8	25.5	11.9	16	19	20.6
MDAAS-08-045	MDACH-08-045	8	7.96	7.92	45	9.42	8	25.5	11.9	16	19	20.6
MDAAS-08-050	MDACH-08-050	8	7.96	7.92	50	9.42	8	25.5	11.9	16	19	20.6
MDAAS-08-060	MDACH-08-060	8	7.96	7.92	60	9.42	8	25.5	11.9	16	19	20.6
MDAAS-08-070	MDACH-08-070	8	7.96	7.92	70	9.42	8	25.5	11.9	16	19	20.6
MDAAS-08-080	MDACH-08-080	8	7.96	7.92	80	9.42	8	25.5	11.9	16	19	20.6
MDAAS-08-090	MDACH-08-090	8	7.96	7.92	90	9.42	8	25.5	11.9	16	19	20.6
MDAAS-08-100	MDACH-08-100	8	7.96	7.92	100	9.42	8	25.5	11.9	16	19	20.6



# QUICK RELEASE BALL LOCK PINS

## Aluminum Dome Handle | Metric (continued)

**MA** MODIFICATIONS AVAILABLE

**EXPANDED LINE**

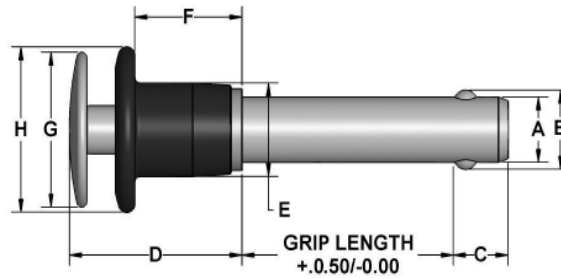

Dia mm	Hole Size mm		Min. Pull-Out Strength (N)	Calculated Double Shear (N)	
	Max	Min		4130 Steel	17-4 Stainless
5	5.1	5.0	890	21,600	24,400
6	6.1	6.0	1,023	31,686	35,640
8	8.1	8.0	2,268	56,712	63,804
10	10.1	10.0	2,558	88,977	100,101
12	12.1	12.0	5,160	128,050	144,060
16	16.1	16.0	9,207	228,602	257,179

4130 Steel Part#	17-4 SS Part#	Nominal Diameter mm	A Max mm	A Min mm	Grip Length mm	+/-0.25 B mm	+/-1.0 C mm	D mm	E mm	F mm	G mm	H mm
MDAAS-10-015	MDACH-10-015	10	9.96	9.92	15	11.86	9	28.4	14.2	17.8	23.6	25.4
MDAAS-10-020	MDACH-10-020	10	9.96	9.92	20	11.86	9	28.4	14.2	17.8	23.6	25.4
MDAAS-10-025	MDACH-10-025	10	9.96	9.92	25	11.86	9	28.4	14.2	17.8	23.6	25.4
MDAAS-10-030	MDACH-10-030	10	9.96	9.92	30	11.86	9	28.4	14.2	17.8	23.6	25.4
MDAAS-10-035	MDACH-10-035	10	9.96	9.92	35	11.86	9	28.4	14.2	17.8	23.6	25.4
MDAAS-10-040	MDACH-10-040	10	9.96	9.92	40	11.86	9	28.4	14.2	17.8	23.6	25.4
MDAAS-10-045	MDACH-10-045	10	9.96	9.92	45	11.86	9	28.4	14.2	17.8	23.6	25.4
MDAAS-10-050	MDACH-10-050	10	9.96	9.92	50	11.86	9	28.4	14.2	17.8	23.6	25.4
MDAAS-10-060	MDACH-10-060	10	9.96	9.92	60	11.86	9	28.4	14.2	17.8	23.6	25.4
MDAAS-10-070	MDACH-10-070	10	9.96	9.92	70	11.86	9	28.4	14.2	17.8	23.6	25.4
MDAAS-10-080	MDACH-10-080	10	9.96	9.92	80	11.86	9	28.4	14.2	17.8	23.6	25.4
MDAAS-10-090	MDACH-10-090	10	9.96	9.92	90	11.86	9	28.4	14.2	17.8	23.6	25.4
MDAAS-10-100	MDACH-10-100	10	9.96	9.92	100	11.86	9	28.4	14.2	17.8	23.6	25.4
MDAAS-12-020	MDACH-12-020	12	11.96	11.92	20	14.45	10	35.9	18.3	21.6	33	34.7
MDAAS-12-025	MDACH-12-025	12	11.96	11.92	25	14.45	10	35.9	18.3	21.6	33	34.7
MDAAS-12-030	MDACH-12-030	12	11.96	11.92	30	14.45	10	35.9	18.3	21.6	33	34.7
MDAAS-12-035	MDACH-12-035	12	11.96	11.92	35	14.45	10	35.9	18.3	21.6	33	34.7
MDAAS-12-040	MDACH-12-040	12	11.96	11.92	40	14.45	10	35.9	18.3	21.6	33	34.7
MDAAS-12-045	MDACH-12-045	12	11.96	11.92	45	14.45	10	35.9	18.3	21.6	33	34.7
MDAAS-12-050	MDACH-12-050	12	11.96	11.92	50	14.45	10	35.9	18.3	21.6	33	34.7
MDAAS-12-060	MDACH-12-060	12	11.96	11.92	60	14.45	10	35.9	18.3	21.6	33	34.7
MDAAS-12-070	MDACH-12-070	12	11.96	11.92	70	14.45	10	35.9	18.3	21.6	33	34.7
MDAAS-12-080	MDACH-12-080	12	11.96	11.92	80	14.45	10	35.9	18.3	21.6	33	34.7
MDAAS-12-090	MDACH-12-090	12	11.96	11.92	90	14.45	10	35.9	18.3	21.6	33	34.7
MDAAS-12-100	MDACH-12-100	12	11.96	11.92	100	14.45	10	35.9	18.3	21.6	33	34.7
MDAAS-16-025	MDACH-16-025	16	15.96	15.92	25	19	14	46.7	23.9	27.9	42.7	44.5
MDAAS-16-030	MDACH-16-030	16	15.96	15.92	30	19	14	46.7	23.9	27.9	42.7	44.5
MDAAS-16-035	MDACH-16-035	16	15.96	15.92	35	19	14	46.7	23.9	27.9	42.7	44.5
MDAAS-16-040	MDACH-16-040	16	15.96	15.92	40	19	14	46.7	23.9	27.9	42.7	44.5
MDAAS-16-045	MDACH-16-045	16	15.96	15.92	45	19	14	46.7	23.9	27.9	42.7	44.5
MDAAS-16-050	MDACH-16-050	16	15.96	15.92	50	19	14	46.7	23.9	27.9	42.7	44.5
MDAAS-16-060	MDACH-16-060	16	15.96	15.92	60	19	14	46.7	23.9	27.9	42.7	44.5
MDAAS-16-070	MDACH-16-070	16	15.96	15.92	70	19	14	46.7	23.9	27.9	42.7	44.5
MDAAS-16-080	MDACH-16-080	16	15.96	15.92	80	19	14	46.7	23.9	27.9	42.7	44.5
MDAAS-16-090	MDACH-16-090	16	15.96	15.92	90	19	14	46.7	23.9	27.9	42.7	44.5
MDAAS-16-100	MDACH-16-100	16	15.96	15.92	100	19	14	46.7	23.9	27.9	42.7	44.5

## QUICK RELEASE BALL LOCK PINS

### Stainless Dome Handle | Inch

**MA** MODIFICATIONS AVAILABLE

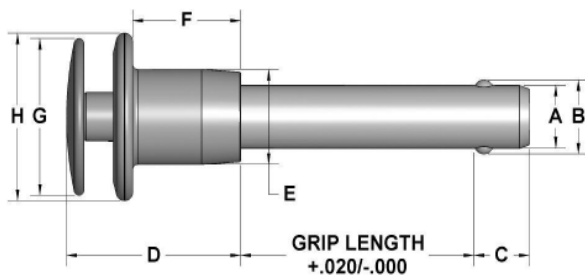

Dia	Hole Size		Min. Pull-Out Strength (lbs)	Calculated Double Shear (lbs)	
	Max	Min		17-4 Stainless	300 Series SS*
3/16	.1940	.1900	200	5,150	—
1/4	.2540	.2500	230	9,200	2,200
5/16	.3165	.3125	510	14,400	3,500
3/8	.3790	.3750	575	20,600	4,500
1/2	.5050	.5000	1,160	36,800	11,500

\*Note: 300 Series Stainless is not recommended in applications where shear forces are a factor.

These positive locking quick release pins have a wide range of uses in fastening, locating, and alignment applications. The pins will not release until the button on the handle is depressed. Once the button is depressed, the balls retract into the shank allowing the pin to be inserted or removed into or out of a hole. They are available in two types of stainless steel to meet your application. Handle has hole for optional wire lanyard attachment. The handles and dome actuator buttons for the pins listed below are made from 303 stainless steel. The large ergonomic dome actuator button facilitates easy installation and removal of the pin. They are ideal in applications where there is repetitive or frequent use of the pin. In addition, they can be used in situations where the operator is wearing gloves or has limited range of hand motion. They also add a unique look and feel that is not available with other pin styles and offer a large area for engraving or stamping to add logos, instructions, etc. For specific application requirements, custom modifications are available for this product line. See page 3 for complete specifications.

17-4 SS Part#	300 Series SS Part#	Nominal Diameter	A Max	A Min	Grip Length	+/- .005 B	+ .000/- .030 C	D	E	F	G	H
DCCH-18-050	—	3/16	.1885	.1870	.50	.220	.260	1.00	.47	.63	.75	.81
DCCH-18-075	—	3/16	.1885	.1870	.75	.220	.260	1.00	.47	.63	.75	.81
DCCH-18-100	—	3/16	.1885	.1870	1.00	.220	.260	1.00	.47	.63	.75	.81
DCCH-18-125	—	3/16	.1885	.1870	1.25	.220	.260	1.00	.47	.63	.75	.81
DCCH-18-150	—	3/16	.1885	.1870	1.50	.220	.260	1.00	.47	.63	.75	.81
DCCH-18-175	—	3/16	.1885	.1870	1.75	.220	.260	1.00	.47	.63	.75	.81
DCCH-18-200	—	3/16	.1885	.1870	2.00	.220	.260	1.00	.47	.63	.75	.81
DCCH-18-250	—	3/16	.1885	.1870	2.50	.220	.260	1.00	.47	.63	.75	.81
DCCH-18-300	—	3/16	.1885	.1870	3.00	.220	.260	1.00	.47	.63	.75	.81
DCCH-18-350	—	3/16	.1885	.1870	3.50	.220	.260	1.00	.47	.63	.75	.81
DCCH-18-400	—	3/16	.1885	.1870	4.00	.220	.260	1.00	.47	.63	.75	.81
DCCH-25-050	DCCS-25-050	1/4	.2485	.2470	.50	.289	.290	1.00	.47	.63	.75	.81
DCCH-25-075	DCCS-25-075	1/4	.2485	.2470	.75	.289	.290	1.00	.47	.63	.75	.81
DCCH-25-100	DCCS-25-100	1/4	.2485	.2470	1.00	.289	.290	1.00	.47	.63	.75	.81
DCCH-25-125	DCCS-25-125	1/4	.2485	.2470	1.25	.289	.290	1.00	.47	.63	.75	.81
DCCH-25-150	DCCS-25-150	1/4	.2485	.2470	1.50	.289	.290	1.00	.47	.63	.75	.81
DCCH-25-175	DCCS-25-175	1/4	.2485	.2470	1.75	.289	.290	1.00	.47	.63	.75	.81
DCCH-25-200	DCCS-25-200	1/4	.2485	.2470	2.00	.289	.290	1.00	.47	.63	.75	.81
DCCH-25-250	DCCS-25-250	1/4	.2485	.2470	2.50	.289	.290	1.00	.47	.63	.75	.81
DCCH-25-300	DCCS-25-300	1/4	.2485	.2470	3.00	.289	.290	1.00	.47	.63	.75	.81
DCCH-25-350	DCCS-25-350	1/4	.2485	.2470	3.50	.289	.290	1.00	.47	.63	.75	.81
DCCH-25-400	DCCS-25-400	1/4	.2485	.2470	4.00	.289	.290	1.00	.47	.63	.75	.81
DCCH-31-050	DCCS-31-050	5/16	.3110	.3095	.50	.375	.330	1.00	.47	.63	.75	.81
DCCH-31-075	DCCS-31-075	5/16	.3110	.3095	.75	.375	.330	1.00	.47	.63	.75	.81
DCCH-31-100	DCCS-31-100	5/16	.3110	.3095	1.00	.375	.330	1.00	.47	.63	.75	.81
DCCH-31-125	DCCS-31-125	5/16	.3110	.3095	1.25	.375	.330	1.00	.47	.63	.75	.81
DCCH-31-150	DCCS-31-150	5/16	.3110	.3095	1.50	.375	.330	1.00	.47	.63	.75	.81
DCCH-31-175	DCCS-31-175	5/16	.3110	.3095	1.75	.375	.330	1.00	.47	.63	.75	.81
DCCH-31-200	DCCS-31-200	5/16	.3110	.3095	2.00	.375	.330	1.00	.47	.63	.75	.81
DCCH-31-250	DCCS-31-250	5/16	.3110	.3095	2.50	.375	.330	1.00	.47	.63	.75	.81
DCCH-31-300	DCCS-31-300	5/16	.3110	.3095	3.00	.375	.330	1.00	.47	.63	.75	.81
DCCH-31-350	DCCS-31-350	5/16	.3110	.3095	3.50	.375	.330	1.00	.47	.63	.75	.81
DCCH-31-400	DCCS-31-400	5/16	.3110	.3095	4.00	.375	.330	1.00	.47	.63	.75	.81



## QUICK RELEASE BALL LOCK PINS

### Stainless Dome Handle 1 Inch (continued)

**MA** MODIFICATIONS AVAILABLE

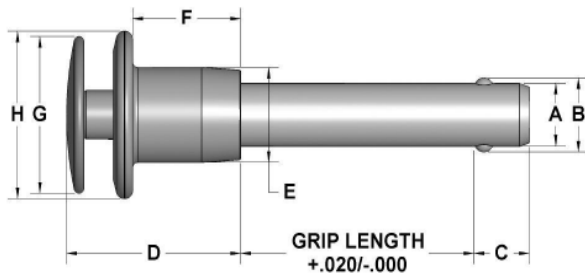

Dia	Hole Size		Min. Pull-Out Strength (lbs)	Calculated Double Shear (lbs)	
	Max	Min		17-4 Stainless	300 Series SS*
3/16	.1940	.1900	200	5,150	—
1/4	.2540	.2500	230	9,200	2,200
5/16	.3165	.3125	510	14,400	3,500
3/8	.3790	.3750	575	20,600	4,500
1/2	.5050	.5000	1,160	36,800	11,500

\*Note: 300 Series Stainless is not recommended in applications where shear forces are a factor.

17-4 SS Part#	300 Series SS Part#	Nominal Diameter	A Max	A Min	Grip Length	+/- .005 B	+ .000/- .030 C	D	E	F	G	H
DCCH-37-050	DCCS-37-050	3/8	.3735	.3720	.50	.440	.365	1.12	.56	.70	.93	1.00
DCCH-37-075	DCCS-37-075	3/8	.3735	.3720	.75	.440	.365	1.12	.56	.70	.93	1.00
DCCH-37-100	DCCS-37-100	3/8	.3735	.3720	1.00	.440	.365	1.12	.56	.70	.93	1.00
DCCH-37-125	DCCS-37-125	3/8	.3735	.3720	1.25	.440	.365	1.12	.56	.70	.93	1.00
DCCH-37-150	DCCS-37-150	3/8	.3735	.3720	1.50	.440	.365	1.12	.56	.70	.93	1.00
DCCH-37-175	DCCS-37-175	3/8	.3735	.3720	1.75	.440	.365	1.12	.56	.70	.93	1.00
DCCH-37-200	DCCS-37-200	3/8	.3735	.3720	2.00	.440	.365	1.12	.56	.70	.93	1.00
DCCH-37-250	DCCS-37-250	3/8	.3735	.3720	2.50	.440	.365	1.12	.56	.70	.93	1.00
DCCH-37-300	DCCS-37-300	3/8	.3735	.3720	3.00	.440	.365	1.12	.56	.70	.93	1.00
DCCH-37-350	DCCS-37-350	3/8	.3735	.3720	3.50	.440	.365	1.12	.56	.70	.93	1.00
DCCH-37-400	DCCS-37-400	3/8	.3735	.3720	4.00	.440	.365	1.12	.56	.70	.93	1.00
DCCH-50-100	DCCS-50-100	1/2	.4985	.4970	1.00	.594	.460	1.41	.72	.85	1.30	1.37
DCCH-50-125	DCCS-50-125	1/2	.4985	.4970	1.25	.594	.460	1.41	.72	.85	1.30	1.37
DCCH-50-150	DCCS-50-150	1/2	.4985	.4970	1.50	.594	.460	1.41	.72	.85	1.30	1.37
DCCH-50-175	DCCS-50-175	1/2	.4985	.4970	1.75	.594	.460	1.41	.72	.85	1.30	1.37
DCCH-50-200	DCCS-50-200	1/2	.4985	.4970	2.00	.594	.460	1.41	.72	.85	1.30	1.37
DCCH-50-250	DCCS-50-250	1/2	.4985	.4970	2.50	.594	.460	1.41	.72	.85	1.30	1.37
DCCH-50-300	DCCS-50-300	1/2	.4985	.4970	3.00	.594	.460	1.41	.72	.85	1.30	1.37
DCCH-50-350	DCCS-50-350	1/2	.4985	.4970	3.50	.594	.460	1.41	.72	.85	1.30	1.37
DCCH-50-400	DCCS-50-400	1/2	.4985	.4970	4.00	.594	.460	1.41	.72	.85	1.30	1.37
DCCH-50-450	DCCS-50-450	1/2	.4985	.4970	4.50	.594	.460	1.41	.72	.85	1.30	1.37
DCCH-50-500	DCCS-50-500	1/2	.4985	.4970	5.00	.594	.460	1.41	.72	.85	1.30	1.37
DCCH-50-550	DCCS-50-550	1/2	.4985	.4970	5.50	.594	.460	1.41	.72	.85	1.30	1.37
DCCH-50-600	DCCS-50-600	1/2	.4985	.4970	6.00	.594	.460	1.41	.72	.85	1.30	1.37

# QUICK RELEASE BALL LOCK PINS

## Stainless Dome Handle | Metric

**MA** MODIFICATIONS AVAILABLE

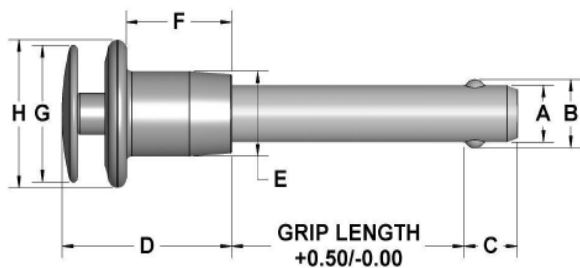

Dia mm	Hole Size Max mm	Hole Size Min mm	Min. Pull-Out Strength (N)	Calculated Double Shear (N) 17-4 Stainless
5	5.1	5.0	890	24,400
6	6.1	6.0	1,023	35,640
8	8.1	8.0	2,268	63,804
10	10.1	10.0	2,558	100,101
12	12.1	12.0	5,160	144,060

These positive locking quick release pins have a wide range of uses in fastening, locating, and alignment applications. The pins will not release until the button on the handle is depressed. Once the button is depressed, the balls retract into the shank allowing the pin to be inserted or removed into or out of a hole. The shanks are made from 17-4PH stainless steel. Handle has hole for optional wire lanyard attachment. The handles and dome actuator buttons for the pins listed below are made from 303 stainless steel. The large ergonomic dome actuator button facilitates easy installation and removal of the pin. They are ideal in applications where there is repetitive or frequent use of the pin. In addition, they can be used in situations where the operator is wearing gloves or has limited range of hand motion. They also add a unique look and feel that is not available with other pin styles and offer a large area for engraving or stamping to add logos, instructions, etc. For specific application requirements, custom modifications are available for this product line. See page 3 for complete specifications. RoHS compliant.

17-4 SS Part #	Nominal Diameter mm	A Max mm	A Min mm	Grip Length mm	+/-0.25 B mm	+/-1.0 C mm	D mm	E mm	F mm	G mm	H mm
MDCCH-05-010	5	4.96	4.92	10	5.54	6	25.5	11.9	16	19	20.6
MDCCH-05-015	5	4.96	4.92	15	5.54	6	25.5	11.9	16	19	20.6
MDCCH-05-020	5	4.96	4.92	20	5.54	6	25.5	11.9	16	19	20.6
MDCCH-05-025	5	4.96	4.92	25	5.54	6	25.5	11.9	16	19	20.6
MDCCH-05-030	5	4.96	4.92	30	5.54	6	25.5	11.9	16	19	20.6
MDCCH-05-035	5	4.96	4.92	35	5.54	6	25.5	11.9	16	19	20.6
MDCCH-05-040	5	4.96	4.92	40	5.54	6	25.5	11.9	16	19	20.6
MDCCH-05-045	5	4.96	4.92	45	5.54	6	25.5	11.9	16	19	20.6
MDCCH-05-050	5	4.96	4.92	50	5.54	6	25.5	11.9	16	19	20.6
MDCCH-05-060	5	4.96	4.92	60	5.54	6	25.5	11.9	16	19	20.6
MDCCH-05-070	5	4.96	4.92	70	5.54	6	25.5	11.9	16	19	20.6
MDCCH-05-080	5	4.96	4.92	80	5.54	6	25.5	11.9	16	19	20.6
MDCCH-05-090	5	4.96	4.92	90	5.54	6	25.5	11.9	16	19	20.6
MDCCH-05-100	5	4.96	4.92	100	5.54	6	25.5	11.9	16	19	20.6
MDCCH-06-010	6	5.96	5.92	10	6.99	7	25.5	11.9	16	19	20.6
MDCCH-06-015	6	5.96	5.92	15	6.99	7	25.5	11.9	16	19	20.6
MDCCH-06-020	6	5.96	5.92	20	6.99	7	25.5	11.9	16	19	20.6
MDCCH-06-025	6	5.96	5.92	25	6.99	7	25.5	11.9	16	19	20.6
MDCCH-06-030	6	5.96	5.92	30	6.99	7	25.5	11.9	16	19	20.6
MDCCH-06-035	6	5.96	5.92	35	6.99	7	25.5	11.9	16	19	20.6
MDCCH-06-040	6	5.96	5.92	40	6.99	7	25.5	11.9	16	19	20.6
MDCCH-06-045	6	5.96	5.92	45	6.99	7	25.5	11.9	16	19	20.6
MDCCH-06-050	6	5.96	5.92	50	6.99	7	25.5	11.9	16	19	20.6
MDCCH-06-060	6	5.96	5.92	60	6.99	7	25.5	11.9	16	19	20.6
MDCCH-06-070	6	5.96	5.92	70	6.99	7	25.5	11.9	16	19	20.6
MDCCH-06-080	6	5.96	5.92	80	6.99	7	25.5	11.9	16	19	20.6
MDCCH-06-090	6	5.96	5.92	90	6.99	7	25.5	11.9	16	19	20.6
MDCCH-06-100	6	5.96	5.92	100	6.99	7	25.5	11.9	16	19	20.6
MDCCH-08-010	8	7.96	7.92	10	9.42	8	25.5	11.9	16	19	20.6
MDCCH-08-015	8	7.96	7.92	15	9.42	8	25.5	11.9	16	19	20.6
MDCCH-08-020	8	7.96	7.92	20	9.42	8	25.5	11.9	16	19	20.6
MDCCH-08-025	8	7.96	7.92	25	9.42	8	25.5	11.9	16	19	20.6
MDCCH-08-030	8	7.96	7.92	30	9.42	8	25.5	11.9	16	19	20.6
MDCCH-08-035	8	7.96	7.92	35	9.42	8	25.5	11.9	16	19	20.6
MDCCH-08-040	8	7.96	7.92	40	9.42	8	25.5	11.9	16	19	20.6
MDCCH-08-045	8	7.96	7.92	45	9.42	8	25.5	11.9	16	19	20.6
MDCCH-08-050	8	7.96	7.92	50	9.42	8	25.5	11.9	16	19	20.6
MDCCH-08-060	8	7.96	7.92	60	9.42	8	25.5	11.9	16	19	20.6
MDCCH-08-070	8	7.96	7.92	70	9.42	8	25.5	11.9	16	19	20.6
MDCCH-08-080	8	7.96	7.92	80	9.42	8	25.5	11.9	16	19	20.6
MDCCH-08-090	8	7.96	7.92	90	9.42	8	25.5	11.9	16	19	20.6
MDCCH-08-100	8	7.96	7.92	100	9.42	8	25.5	11.9	16	19	20.6



## QUICK RELEASE BALL LOCK PINS

### Stainless Dome Handle | Metric (continued)

**MA** MODIFICATIONS AVAILABLE

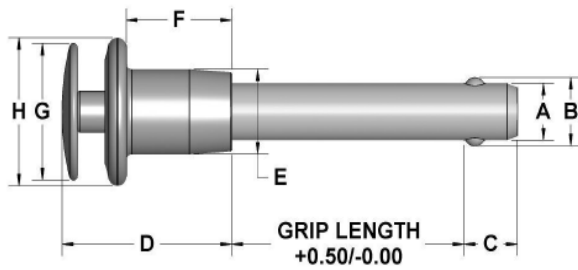

Dia mm	Hole Size Max mm	Hole Size Min mm	Min. Pull-Out Strength (N)	Calculated Double Shear (N) 17-4 Stainless
5	5.1	5.0	890	24,400
6	6.1	6.0	1,023	35,640
8	8.1	8.0	2,268	63,804
10	10.1	10.0	2,558	100,101
12	12.1	12.0	5,160	144,060

17-4 SS Part #	Nominal Diameter mm	A Max mm	A Min mm	Grip Length mm	+/-0.25 B mm	+/-1.0 C mm	D mm	E mm	F mm	G mm	H mm
MDCCH-10-015	10	9.96	9.92	15	11.86	9	28.4	14.2	17.8	23.6	25.4
MDCCH-10-020	10	9.96	9.92	20	11.86	9	28.4	14.2	17.8	23.6	25.4
MDCCH-10-025	10	9.96	9.92	25	11.86	9	28.4	14.2	17.8	23.6	25.4
MDCCH-10-030	10	9.96	9.92	30	11.86	9	28.4	14.2	17.8	23.6	25.4
MDCCH-10-035	10	9.96	9.92	35	11.86	9	28.4	14.2	17.8	23.6	25.4
MDCCH-10-040	10	9.96	9.92	40	11.86	9	28.4	14.2	17.8	23.6	25.4
MDCCH-10-045	10	9.96	9.92	45	11.86	9	28.4	14.2	17.8	23.6	25.4
MDCCH-10-050	10	9.96	9.92	50	11.86	9	28.4	14.2	17.8	23.6	25.4
MDCCH-10-060	10	9.96	9.92	60	11.86	9	28.4	14.2	17.8	23.6	25.4
MDCCH-10-070	10	9.96	9.92	70	11.86	9	28.4	14.2	17.8	23.6	25.4
MDCCH-10-080	10	9.96	9.92	80	11.86	9	28.4	14.2	17.8	23.6	25.4
MDCCH-10-090	10	9.96	9.92	90	11.86	9	28.4	14.2	17.8	23.6	25.4
MDCCH-10-100	10	9.96	9.92	100	11.86	9	28.4	14.2	17.8	23.6	25.4
MDCCH-12-020	12	11.96	11.92	20	14.45	10	35.9	18.3	21.6	33	34.7
MDCCH-12-025	12	11.96	11.92	25	14.45	10	35.9	18.3	21.6	33	34.7
MDCCH-12-030	12	11.96	11.92	30	14.45	10	35.9	18.3	21.6	33	34.7
MDCCH-12-035	12	11.96	11.92	35	14.45	10	35.9	18.3	21.6	33	34.7
MDCCH-12-040	12	11.96	11.92	40	14.45	10	35.9	18.3	21.6	33	34.7
MDCCH-12-045	12	11.96	11.92	45	14.45	10	35.9	18.3	21.6	33	34.7
MDCCH-12-050	12	11.96	11.92	50	14.45	10	35.9	18.3	21.6	33	34.7
MDCCH-12-060	12	11.96	11.92	60	14.45	10	35.9	18.3	21.6	33	34.7
MDCCH-12-070	12	11.96	11.92	70	14.45	10	35.9	18.3	21.6	33	34.7
MDCCH-12-080	12	11.96	11.92	80	14.45	10	35.9	18.3	21.6	33	34.7
MDCCH-12-090	12	11.96	11.92	90	14.45	10	35.9	18.3	21.6	33	34.7
MDCCH-12-100	12	11.96	11.92	100	14.45	10	35.9	18.3	21.6	33	34.7

## BALL LOCK PIN FLANGE RECEPTACLES

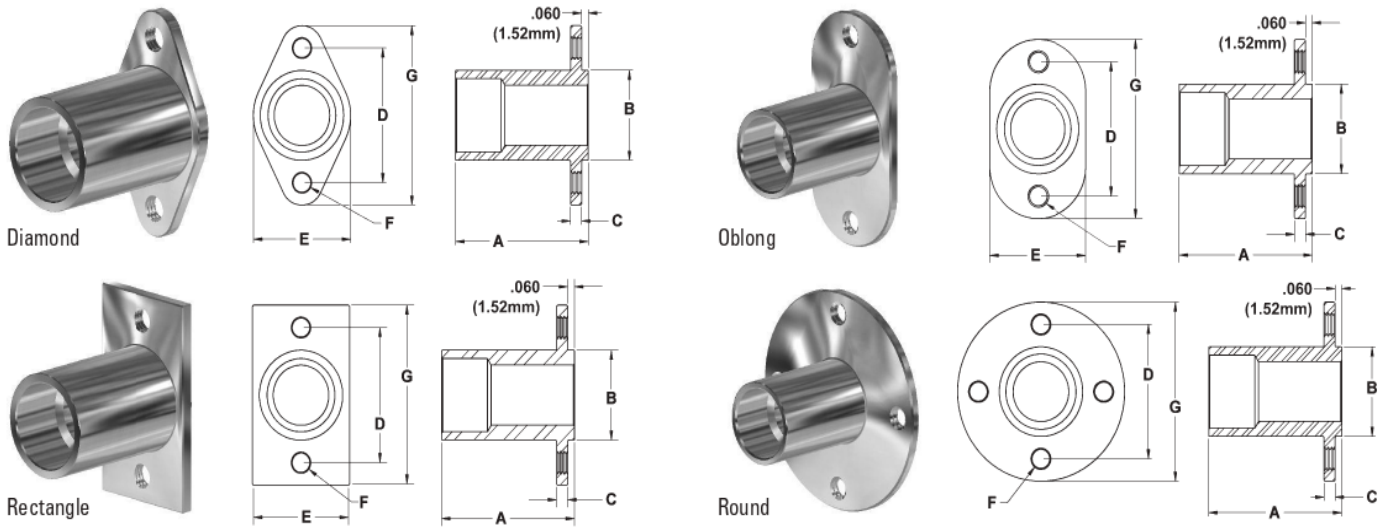

The flanged receptacles provide a permanent and proper mating hole for quick release ball lock pins. They are designed for use on materials and in applications where the pin does not have anything to lock against. Because the pin does not protrude through the bottom of the receptacles, they are ideal for blind-hole applications. The receptacles can be mounted with screws, rivets or bolts. They are made from 303 stainless steel. The "Grip Length Reduction" is the amount of pin that is inside the receptacle and reducing the useable length of the pin by this amount. The quick release ball lock pins are inserted from the flanged end.

### INCH

Part #	For Use With Pin Diameter	Flange Style	+0.00/-0.005 A	+/-0.005 B	+/-0.005 C	+/-0.005 D	+/-0.010 E	F	+/-0.010 G	Grip Length Reduction
DIFR-187	3/16	Diamond	.650	.375	.060	1.000	.625	6-32	1.250	.375
DIFR-250	1/4	Diamond	.650	.375	.060	1.000	.625	6-32	1.250	.375
DIFR-312	5/16	Diamond	.783	.469	.060	1.000	.625	6-32	1.250	.500
DIFR-375	3/8	Diamond	.913	.562	.060	1.000	.625	6-32	1.250	.562
DIFR-500	1/2	Diamond	1.195	.750	.100	1.125	.875	10-32	1.500	.750
OBFR-187	3/16	Oblong	.650	.375	.060	1.000	.625	6-32	1.250	.375
OBFR-250	1/4	Oblong	.650	.375	.060	1.000	.625	6-32	1.250	.375
OBFR-312	5/16	Oblong	.783	.469	.060	1.000	.625	6-32	1.250	.500
OBFR-375	3/8	Oblong	.913	.562	.060	1.000	.625	6-32	1.250	.562
OBFR-500	1/2	Oblong	1.195	.750	.100	1.125	.875	10-32	1.500	.750
REFR-187	3/16	Rectangle	.650	.375	.060	1.000	.625	6-32	1.250	.375
REFR-250	1/4	Rectangle	.650	.375	.060	1.000	.625	6-32	1.250	.375
REFR-312	5/16	Rectangle	.783	.469	.060	1.000	.625	6-32	1.250	.500
REFR-375	3/8	Rectangle	.913	.562	.060	1.000	.625	6-32	1.250	.562
ROFR-187	3/16	Round	.650	.375	.060	1.000	—	6-32	1.250	.375
ROFR-250	1/4	Round	.650	.375	.060	1.000	—	6-32	1.250	.375
ROFR-312	5/16	Round	.783	.469	.060	1.000	—	6-32	1.250	.500
ROFR-375	3/8	Round	.913	.562	.060	1.000	—	6-32	1.250	.562
ROFR-500	1/2	Round	1.195	.750	.100	1.125	—	10-32	1.500	.750

### METRIC

Part #	For Use With Pin Diameter	Flange Style	+0.00/-0.13 A mm	+/-0.13 B mm	+/-0.13 C mm	+/-0.13 D mm	+/-0.25 E mm	F mm	+/-0.25 G mm	Grip Length Reduction mm
MDIFR-05	5mm	Diamond	16.51	9.53	1.52	25	15.88	M4	31.75	10
MDIFR-06	6mm	Diamond	16.51	9.53	1.52	25	15.88	M4	31.75	10
MDIFR-08	8mm	Diamond	19.89	11.91	1.52	25	15.88	M4	31.75	13
MDIFR-10	10mm	Diamond	23.19	14.29	1.52	25	15.88	M4	31.75	15
MDIFR-12	12mm	Diamond	30.35	19.05	2.54	29	22.23	M5	38.10	20
MOBFR-05	5mm	Oblong	16.51	9.53	1.52	25	15.88	M4	31.75	10
MOBFR-06	6mm	Oblong	16.51	9.53	1.52	25	15.88	M4	31.75	10
MOBFR-08	8mm	Oblong	19.89	11.91	1.52	25	15.88	M4	31.75	13
MOBFR-10	10mm	Oblong	23.19	14.29	1.52	25	15.88	M4	31.75	15
MOBFR-12	12mm	Oblong	30.35	19.05	2.54	29	22.23	M5	38.10	20
MREFR-05	5mm	Rectangle	16.51	9.53	1.52	25	15.88	M4	31.75	10
MREFR-06	6mm	Rectangle	16.51	9.53	1.52	25	15.88	M4	31.75	10
MREFR-08	8mm	Rectangle	19.89	11.91	1.52	25	15.88	M4	31.75	13
MREFR-10	10mm	Rectangle	23.19	14.29	1.52	25	15.88	M4	31.75	15
MROFR-05	5mm	Round	16.51	9.53	1.52	25	—	M4	31.75	10
MROFR-06	6mm	Round	16.51	9.53	1.52	25	—	M4	31.75	10
MROFR-08	8mm	Round	19.89	11.91	1.52	25	—	M4	31.75	13
MROFR-10	10mm	Round	23.19	14.29	1.52	25	—	M4	31.75	15
MROFR-12	12mm	Round	30.35	19.05	2.54	29	—	M5	38.10	20

## BALL LOCK PIN END CAPS



These end caps fit over the end of the quick release ball lock pin and allow the pins to be used in applications where the receiving hole is not within tolerance or is out of round. The receiver caps can replace cotter pins and hitch pins to allow you to take advantage of quick changing and fieldwork without tools. The caps are made from 303 stainless steel. The "Grip Length Reduction" is the amount of pin that is inside the end cap which reduces the useable length of the pin by this amount. The end caps with the tapped ends allow the user to attach a lanyard to the end cap so it does not get lost while not in use. A stainless button head cap screw is included with the tapped hole style.

### INCH

Plain End Part #	Tapped End Part #	For Use With Pin Diameter	A Diameter	B Length	C* Screw Depth	D Thread	Grip Length Reduction
RC-187	RCT-187	3/16	.375	.580	.12	10-32	.125
RC-250	RCT-250	1/4	.375	.580	.12	10-32	.125
RC-312	RCT-312	5/16	.500	.625	.12	10-32	.125
RC-375	RCT-375	3/8	.563	.730	.18	10-32	.187
RC-500	RCT-500	1/2	.750	1.000	.18	10-32	.250
RC-625	RCT-625	5/8	1.000	1.250	.18	1/4-28	.250

\* Maximum Screw Depth

### METRIC

Plain End Part #	Tapped End Part #	For Use With Pin Diameter	A Diameter mm	B Length mm	C* Screw Depth mm	D Thread mm	Grip Length Reduction mm
MRC-05	MRCT-05	5mm	9.53	14.73	3	M5	3
MRC-06	MRCT-06	6mm	9.53	14.73	3	M5	3
MRC-08	MRCT-08	8mm	12.70	15.88	3	M5	3
MRC-10	MRCT-10	10mm	14.29	18.54	4	M5	5
MRC-12	MRCT-12	12mm	19.05	25.40	4	M5	6
MRC-16	MRCT-16	16mm	25.40	31.75	5	M6	6

\* Maximum Screw Depth

### How To Use

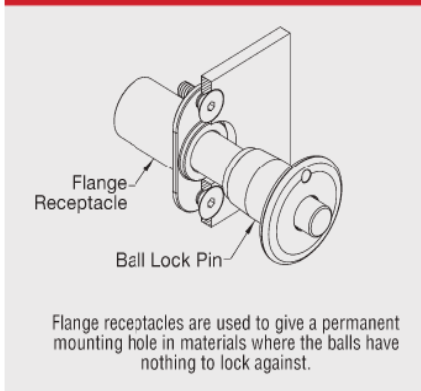

### How To Use

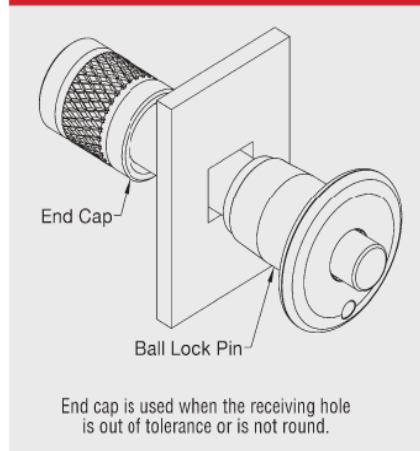

## WIRE ROPE LANYARD ASSEMBLIES

**MA** MODIFICATIONS AVAILABLE



### Tab Styles Rectangular - Stainless

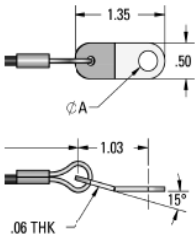

**Tab**  
R20 (A = 20)  
R28 (A = 28)

### Rectangular - Aluminum

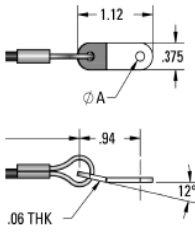

**Tab**  
RA13 (A = 13)  
RA20 (A = 20)

### Teardrop - Stainless

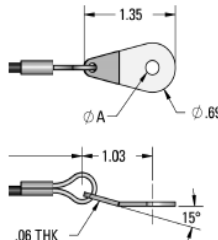

**Tab**  
T13 (A = 13)  
T20 (A = 20)  
T28 (A = 28)

### Wire Rope Lanyard Assembly Specifications

Wire Rope:	7x7 Stainless Steel Wire (RR-W-410)
Covering:	Vinyl (MIL-I-631)
Covered Wire Sizes:	3/64" Wire – Covering to 1/16" 1/16" Wire – Covering to 1/8"
Rated Strength with Tabs:	3/64" Wire = 270 lbs. 1/16" Wire = 480 lbs.
Rated Strength with Eyelets:	30 lbs.
Sleeves:	Copper - Zinc Plated (MIL-51844) Stainless Steel (MIL-51844)
Tabs: R20, R28, T13, T20, T28	300 Series Stainless Steel (ASTM AA240/A666)
Tabs: RA13, RA20	2024 T3/T4 Aluminum, Clear Anodized Finish
Eyelets: E20	300 Series Stainless Steel

Wire rope lanyard assemblies are used to attach quick release pins to a fixture or frame, to prevent the pins from being misplaced while they are not in use. All of the wire rope lanyard assemblies listed below are supplied with 7 x 7 stainless steel wire and are available either uncovered (bare cable) or covered. The vinyl covered assemblies are available in either clear, black, or green and have a temperature range of -30°/+180°F. Tabs are available in both 300 series stainless steel and aluminum. The eyelets are manufactured from 300 series stainless steel. The assemblies are available with either zinc-plated or stainless sleeves. For specific application requirements, custom modifications are available for this product line. To order loop-tab parts, add desired tab style to part number. Sample LCL-3-06-R20.

### Loop - Tab

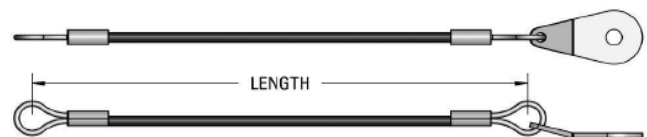
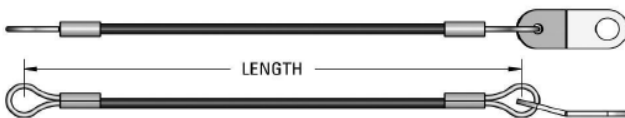

### ZINC-PLATED SLEEVES

Clear Part #	Black Part #	Green Part #	Uncovered Part #	Wire Diameter	Wire Length	Tab
LCL-3-06-*	LBK-3-06-*	LGR-3-06-*	LNC-3-06-*	3/64	6	R20 / R28 / RA13 / RA20 / T13 / T20 / T28
LCL-3-08-*	LBK-3-08-*	LGR-3-08-*	LNC-3-08-*	3/64	8	R20 / R28 / RA13 / RA20 / T13 / T20 / T28
LCL-3-10-*	LBK-3-10-*	LGR-3-10-*	LNC-3-10-*	3/64	10	R20 / R28 / RA13 / RA20 / T13 / T20 / T28
LCL-3-12-*	LBK-3-12-*	LGR-3-12-*	LNC-3-12-*	3/64	12	R20 / R28 / RA13 / RA20 / T13 / T20 / T28
LCL-1-06-*	LBK-1-06-*	LGR-1-06-*	LNC-1-06-*	1/16	6	R20 / R28 / RA13 / RA20 / T13 / T20 / T28
LCL-1-08-*	LBK-1-08-*	LGR-1-08-*	LNC-1-08-*	1/16	8	R20 / R28 / RA13 / RA20 / T13 / T20 / T28
LCL-1-10-*	LBK-1-10-*	LGR-1-10-*	LNC-1-10-*	1/16	10	R20 / R28 / RA13 / RA20 / T13 / T20 / T28
LCL-1-12-*	LBK-1-12-*	LGR-1-12-*	LNC-1-12-*	1/16	12	R20 / R28 / RA13 / RA20 / T13 / T20 / T28

\* Add the desired tab style.

### STAINLESS STEEL SLEEVES

Clear Part #	Black Part #	Green Part #	Uncovered Part #	Wire Diameter	Wire Length	Tab
LCLC3-06*	LBKC3-06*	LGRC3-06*	LNCC3-06*	3/64	6	R20 / R28 / RA13 / RA20 / T13 / T20 / T28
LCLC3-08*	LBKC3-08*	LGRC3-08*	LNCC3-08*	3/64	8	R20 / R28 / RA13 / RA20 / T13 / T20 / T28
LCLC3-10*	LBKC3-10*	LGRC3-10*	LNCC3-10*	3/64	10	R20 / R28 / RA13 / RA20 / T13 / T20 / T28
LCLC3-12*	LBKC3-12*	LGRC3-12*	LNCC3-12*	3/64	12	R20 / R28 / RA13 / RA20 / T13 / T20 / T28
LCLC1-06*	LBKC1-06*	LGRC1-06*	LNCC1-06*	1/16	6	R20 / R28 / RA13 / RA20 / T13 / T20 / T28
LCLC1-08*	LBKC1-08*	LGRC1-08*	LNCC1-08*	1/16	8	R20 / R28 / RA13 / RA20 / T13 / T20 / T28
LCLC1-10*	LBKC1-10*	LGRC1-10*	LNCC1-10*	1/16	10	R20 / R28 / RA13 / RA20 / T13 / T20 / T28
LCLC1-12*	LBKC1-12*	LGRC1-12*	LNCC1-12*	1/16	12	R20 / R28 / RA13 / RA20 / T13 / T20 / T28

\* Add the desired tab style.

## WIRE ROPE LANYARD ASSEMBLIES (cont.)

### Loop - Eyelet

**MA** MODIFICATIONS AVAILABLE

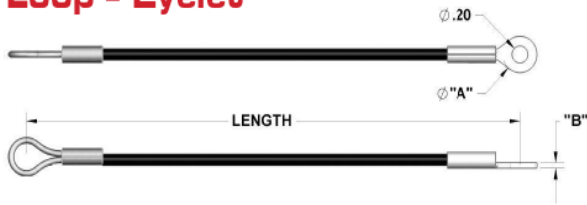

#### ZINC-PLATED SLEEVES

Clear Part #	Black Part #	Green Part #	Uncovered Part #	Wire Diameter	Wire Length	A	B	Eyelet Hole Size
LCL-3-06-E20	LBK-3-06-E20	LGR-3-06-E20	LNC-3-06-E20	3/64	6	.33	.04	.20
LCL-3-08-E20	LBK-3-08-E20	LGR-3-08-E20	LNC-3-08-E20	3/64	8	.33	.04	.20
LCL-3-10-E20	LBK-3-10-E20	LGR-3-10-E20	LNC-3-10-E20	3/64	10	.33	.04	.20
LCL-3-12-E20	LBK-3-12-E20	LGR-3-12-E20	LNC-3-12-E20	3/64	12	.33	.04	.20
LCL-1-06-E20	LBK-1-06-E20	LGR-1-06-E20	LNC-1-06-E20	1/16	6	.41	.06	.20
LCL-1-08-E20	LBK-1-08-E20	LGR-1-08-E20	LNC-1-08-E20	1/16	8	.41	.06	.20
LCL-1-10-E20	LBK-1-10-E20	LGR-1-10-E20	LNC-1-10-E20	1/16	10	.41	.06	.20
LCL-1-12-E20	LBK-1-12-E20	LGR-1-12-E20	LNC-1-12-E20	1/16	12	.41	.06	.20

#### STAINLESS STEEL SLEEVES

Clear Part #	Black Part #	Green Part #	Uncovered Part #	Wire Diameter	Wire Length	A	B	Eyelet Hole Size
LCLC3-06E20	LBKC3-06E20	LGRC3-06E20	LNCC3-06E20	3/64	6	.33	.04	.20
LCLC3-08E20	LBKC3-08E20	LGRC3-08E20	LNCC3-08E20	3/64	8	.33	.04	.20
LCLC3-10E20	LBKC3-10E20	LGRC3-10E20	LNCC3-10E20	3/64	10	.33	.04	.20
LCLC3-12E20	LBKC3-12E20	LGRC3-12E20	LNCC3-12E20	3/64	12	.33	.04	.20
LCLC1-06E20	LBKC1-06E20	LGRC1-06E20	LNCC1-06E20	1/16	6	.41	.06	.20
LCLC1-08E20	LBKC1-08E20	LGRC1-08E20	LNCC1-08E20	1/16	8	.41	.06	.20
LCLC1-10E20	LBKC1-10E20	LGRC1-10E20	LNCC1-10E20	1/16	10	.41	.06	.20
LCLC1-12E20	LBKC1-12E20	LGRC1-12E20	LNCC1-12E20	1/16	12	.41	.06	.20

### Loop - Loop



#### ZINC-PLATED SLEEVES

Clear Part #	Black Part #	Green Part #	Uncovered Part #	Wire Diameter	Wire Length
LCL-3-06	LBK-3-06	LGR-3-06	LNC-3-06	3/64	6
LCL-3-08	LBK-3-08	LGR-3-08	LNC-3-08	3/64	8
LCL-3-10	LBK-3-10	LGR-3-10	LNC-3-10	3/64	10
LCL-3-12	LBK-3-12	LGR-3-12	LNC-3-12	3/64	12
LCL-1-06	LBK-1-06	LGR-1-06	LNC-1-06	1/16	6
LCL-1-08	LBK-1-08	LGR-1-08	LNC-1-08	1/16	8
LCL-1-10	LBK-1-10	LGR-1-10	LNC-1-10	1/16	10
LCL-1-12	LBK-1-12	LGR-1-12	LNC-1-12	1/16	12

#### STAINLESS STEEL SLEEVES

Clear Part #	Black Part #	Green Part #	Uncovered Part #	Wire Diameter	Wire Length
LCLC3-06	LBKC3-06	LGRC3-06	LNCC3-06	3/64	6
LCLC3-08	LBKC3-08	LGRC3-08	LNCC3-08	3/64	8
LCLC3-10	LBKC3-10	LGRC3-10	LNCC3-10	3/64	10
LCLC3-12	LBKC3-12	LGRC3-12	LNCC3-12	3/64	12
LCLC1-06	LBKC1-06	LGRC1-06	LNCC1-06	1/16	6
LCLC1-08	LBKC1-08	LGRC1-08	LNCC1-08	1/16	8
LCLC1-10	LBKC1-10	LGRC1-10	LNCC1-10	1/16	10
LCLC1-12	LBKC1-12	LGRC1-12	LNCC1-12	1/16	12

### Split Rings

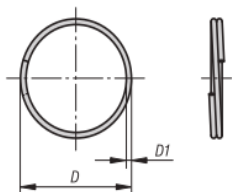

Used for attaching ball lock pins to a lanyard. Prevents the pin from being lost when not in use. Made from 302 stainless steel.

Part #	D	D1
RSC-37	.962	.072

## PULL PINS

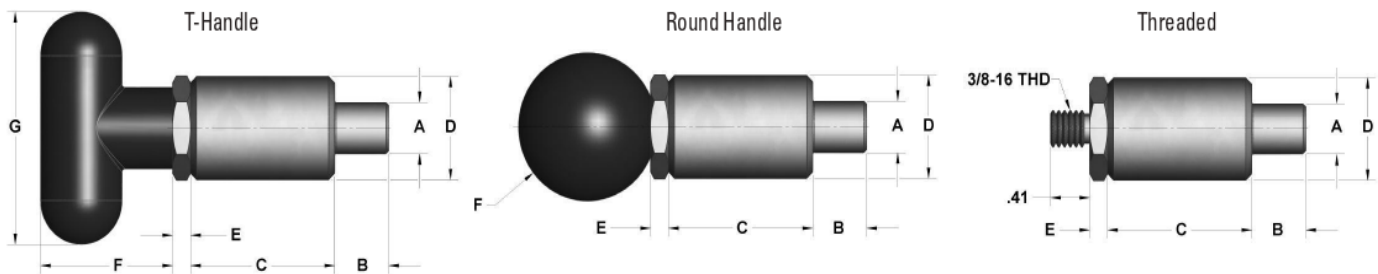

These spring loaded pull pins allow you to quickly retract and engage the plunger for locating, fastening and quick change operations. They consist of two parts which include a housing (barrel) and a plunger assembly. The plunger assembly screws into the housing. The housing is designed to be welded into place for strength. Pulling on the handle of the plunger assembly retracts the plunger into the housing. Releasing the handle allows the spring loaded plunger to extend. The lockout style allows you to pull and rotate the handle 1/4 turn to hold the plunger in the retracted position. The style without handles feature a 3/8-16 threaded end so the user can add a different handle or other method of actuation. The zinc plated steel plunger assemblies are made from C1038 steel on all sizes except the 5/8 which is made from 12L15 steel. The steel housing is made from 12L15 steel for welding to the fixture and is not plated. The aluminum housings are made from 6061-T6. The stainless steel models (plunger assembly and housing) are made from 303 stainless steel. Pull up force is approximately 5 lbs. Handles are made from black plastic.

### T-HANDLE - NON-LOCKING

Steel Plunger Steel Housing Part #	Steel Plunger Alum Housing Part #	SS Plunger SS Housing Part #	+0.012 -0.010 A	B	C	+0.000 -0.005 D	E	F	G
CP-K25T	CP-K25TAL	—	1/4	9/16	1-1/2	1.000	3/16	1-7/16	2-1/4
CP-K100T	CP-K100TAL	CP-K100TSS	3/8	9/16	1-1/2	1.000	3/16	1-7/16	2-1/4
CP-K200T	CP-K200TAL	CP-K200TSS	1/2	9/16	1-1/2	1.000	3/16	1-7/16	2-1/4
CP-K320T	CP-K320TAL	CP-K320TSS	1/2	9/16	2-1/4	1.000	3/16	1-7/16	2-1/4
CP-K420T	CP-K420TAL	—	5/8	9/16	2-1/4	1.000	3/16	1-7/16	2-1/4

### T-HANDLE - WITH LOCKOUT

Steel Plunger Steel Housing Part #	Steel Plunger Alum Housing Part #	SS Plunger SS Housing Part #	+0.012 -0.010 A	B	C	+0.000 -0.005 D	E	F	G
CP-K25TLO	CP-K25TLOAL	—	1/4	9/16	1-1/2	1.000	3/16	1-7/16	2-1/4
CP-K100TLO	CP-K100TLOAL	CP-K100TLOSS	3/8	9/16	1-1/2	1.000	3/16	1-7/16	2-1/4
CP-K200TLO	CP-K200TLOAL	CP-K200TLOSS	1/2	9/16	1-1/2	1.000	3/16	1-7/16	2-1/4
CP-K320TLO	CP-K320TLOAL	CP-K320TLOSS	1/2	9/16	2-1/4	1.000	3/16	1-7/16	2-1/4
CP-K420TLO	CP-K420TLOAL	—	5/8	9/16	2-1/4	1.000	3/16	1-7/16	2-1/4

### ROUND HANDLE - NON-LOCKING

Steel Plunger Steel Housing Part #	Steel Plunger Alum Housing Part #	SS Plunger SS Housing Part #	+0.012 -0.010 A	B	C	+0.000 -0.005 D	E	F
CP-K25R	CP-K25RAL	—	1/4	9/16	1-1/2	1.000	3/16	1-3/8
CP-K100R	CP-K100RAL	CP-K100RSS	3/8	9/16	1-1/2	1.000	3/16	1-3/8
CP-K200R	CP-K200RAL	CP-K200RSS	1/2	9/16	1-1/2	1.000	3/16	1-3/8
CP-K320R	CP-K320RAL	CP-K320RSS	1/2	9/16	2-1/4	1.000	3/16	1-3/8
CP-K420R	CP-K420RAL	—	5/8	9/16	2-1/4	1.000	3/16	1-3/8

### ROUND HANDLE - WITH LOCKOUT

Steel Plunger Steel Housing Part #	Steel Plunger Alum Housing Part #	SS Plunger SS Housing Part #	+0.012 -0.010 A	B	C	+0.000 -0.005 D	E	F
CP-K25RLO	CP-K25RLOAL	—	1/4	9/16	1-1/2	1.000	3/16	1-3/8
CP-K100RLO	CP-K100RLOAL	CP-K100RLOSS	3/8	9/16	1-1/2	1.000	3/16	1-3/8
CP-K200RLO	CP-K200RLOAL	CP-K200RLOSS	1/2	9/16	1-1/2	1.000	3/16	1-3/8
CP-K320RLO	CP-K320RLOAL	CP-K320RLOSS	1/2	9/16	2-1/4	1.000	3/16	1-3/8
CP-K420RLO	CP-K420RLOAL	—	5/8	9/16	2-1/4	1.000	3/16	1-3/8

### THREADED END - NON-LOCKING

Steel Plunger Steel Housing Part #	Steel Plunger Alum Housing Part #	SS Plunger SS Housing Part #	+0.012 -0.010 A	B	C	+0.000 -0.005 D	E
CP-K25NK	CP-K25NKAL	—	1/4	9/16	1-1/2	1.000	3/16
CP-K100NK	CP-K100NKAL	CP-K100NKSS	3/8	9/16	1-1/2	1.000	3/16
CP-K200NK	CP-K200NKAL	CP-K200NKSS	1/2	9/16	1-1/2	1.000	3/16
CP-K320NK	CP-K320NKAL	CP-K320NKSS	1/2	9/16	2-1/4	1.000	3/16
CP-K420NK	CP-K420NKAL	—	5/8	9/16	2-1/4	1.000	3/16

### HOUSINGS ONLY

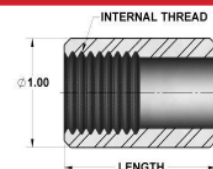

Steel Housing Part #	Alum Housing Part #	SS Housing Part #	Internal Thread	Length
CP-K102-B0	CP-K102AL-B0	CP-K102SS-B0	3/4-10	1-1/2
CP-K102L-B0	CP-K102LAL-B0	CP-K102LSS-B0	3/4-10	2-1/4

## Doing Business with Fairlane Products...

### Purchasing From Fairlane Products

All items listed in this catalog are sold through a network of approved distributors. Original Equipment Manufacturers (OEM) may be able to purchase directly based on quantity, item and other criteria. Please call us at 586-294-6100 for assistance with any questions about purchasing or locating a distributor.

### Website

Our website at [www.fairlaneproducts.com](http://www.fairlaneproducts.com) was developed to allow users easy access to a full array of services. Within our website you can easily search our entire product line for the exact part to fit your application. Full product information including materials, dimension and other technical data is available. In addition, CAD models can be viewed and downloaded in a variety of formats so you can integrate the parts directly into your CAD database or projects.

### Business Hours

Representatives are available to assist you from 8:00 a.m. to 4:30 p.m. Eastern Time, Monday through Friday.

### Pricing

OEM quantity price discounts are available for many items and apply to the quantity of each specific part. We do our best to hold pricing, however, any published prices are subject to change without notice. Quoted prices will be valid for 30 days.

### Shipments

All items in this catalog are normally stocked. Backordered parts are always given a high priority and will ship as soon as they become available. For OEM customers, normal shipment is UPS – FOB Fraser Michigan unless otherwise noted. Shipping charges are prepaid and added to the invoice. Special charges and guidelines apply to shipments outside the United States. Buyers are responsible for all applicable taxes and duties on international shipments.

### Returns

An RGA number must be issued before returning any products. All returns must be shipped via UPS and reference the RGA number on the outside of the box. Custom products cannot be returned.

### Custom Products

Some products may be modified to meet your exact specifications. Please inquire for pricing. Once custom made products are in process, the order may not be cancelled. Custom made products cannot be returned.

### Material Data Safety Sheets

Material Data Safety Sheets are available upon request.

### Specifications

We do our best to represent our products as accurately as possible in both our catalogs and website, however, all specifications are subject to change without notice.

### Choice of Law

The terms of sale for purchases from Fairlane Products shall be governed by and construed in accordance with the laws of the State of Michigan as applied to contracts made and to be performed in Michigan. Any action arising out of such purchases must be brought in courts in Michigan. Purchasers consent to the jurisdiction of the courts in Michigan and to service of process by registered mail, return receipt requested, or by other manner proved by law.

### Entire Agreement

By placement of an order or by acceptance of goods ordered, buyer signifies agreement that no terms, conditions or warranties other than those stated here, and no agreement or understanding, oral or written, in any way purporting to modify these terms, conditions and or warranties, whether contained in buyer's purchase order or elsewhere, shall be binding on Fairlane Products.

### Customer Comments

Everyone at Fairlane Products takes great pride in their work and truly strives for complete customer satisfaction. If you ever have any comments or suggestions on our products, service, catalogs or website, please let us know. They are appreciated and taken seriously.