



ACME
INDUSTRIAL
COMPANY

PRECISION **BUSHINGS**



DRILL BUSHINGS



GUN DRILL BUSHINGS



TOOL HOLDER BUSHINGS

AS9100C
AND
ISO 9001:2008
REGISTERED
QUALITY SYSTEM

CATAL



Get quote »

Angic Global Solutions

1-888-872-0690

<https://www.AngicGlobal.com> Sales@AngicGlobal.com

How High Are Your Standards?

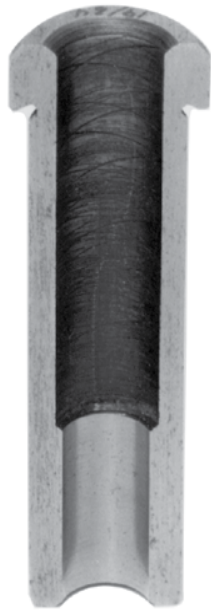

Theirs
- Counterbored
- Case Hardened



Ours
- **No Counterbore**
*Full bearing surface supports the tool for the entire length of bushing. You'll drill more **precise** holes plus your Acme bushing will last **longer**.*

- **Hardened**
61-65 R_C means less machine downtime to change worn bushings.

Acme maintains the highest standards for just about every kind of bushing you'd ever need, including tap holder and tool holder bushings, boring bar sleeves, gun drill bushings, liners and more.



The Standard Components With the Highest Standards



Acme Industrial Company

441 Maple Avenue • Carpentersville, IL 60110-1990

Tel: (847) 428-3911 • (800) 323-5582 • Fax: (847) 428-1820

Web: www.acmeindustrial.com • E-mail: acmemail@acmeindustrial.com

**AS9100C
AND
ISO 9001:2008
REGISTERED
QUALITY SYSTEM**



Get quote »

Angic Global Solutions

1-888-872-0690

<https://www.AngicGlobal.com> Sales@AngicGlobal.com



CONTENTS

Selection Tips	2
Installation Tips	4
Specifications	5
STANDARD DRILL BUSHINGS - INCH	
Headless Press Fit - Type P	6
Head Press Fit - Type H	10
Slip-Fixed Renewable - Type SF	14
Headless Liners - Type L	17
Head Liners - Type HL	20
SPECIAL PURPOSE BUSHINGS - INCH	
Extended Range Bushings	
Headless Press Fit - Type P	21
Head Press Fit - Type H	22
Slip-Fixed Renewable - Type SF	23
Headless Liners - Type L	24
Head Liners - Type HL	25
Extra-Thinwall Bushings	26
Embedment Bushings	27
Tungsten Carbide Bushings	
Headless Press Fit - Type CP	28
Head Press Fit - Type CH	28
Slip-Fixed Renewable - Type CSF	29
Gun Drill Bushings	
Type GDB	30
Type GDX	30
Liners - Type GDL	31
Inserts - Type GDI	31
Oil Groove Bushings	32
Special/Custom Drill Bushings	34
LOCKSCREWS & CLAMPS - INCH	33
TOOL HOLDER BUSHINGS - INCH	
CNC Style - Type Z	35
Split Style - Type B	36
Solid Style - Type J	37
Slotted Style - Type C	38
Boring Bar Sleeves	39
STANDARD DRILL BUSHINGS - METRIC	
Technical Information	40
Plain Press Fit - Type PM	42
Head Press Fit - Type HM	44
Slip-Fixed Renewable - Type SFM	46
Plain Liners - Type PM	48
Head Liners - Type HM	50
LOCKSCREWS & CLAMPS - METRIC	52
Decimal Conversion Chart	BC

SELECTION TIPS



“The best bushing for the job – at the right price, right now.”

You can be sure with ACME that you're buying the best bushing for the job. Bushings and accessories have been the backbone of our business since 1914. Our nationwide network of industrial distributors further assures you of prompt personal service.

The following summaries of typical uses for bushings and liners prefaces our simplified, easy to use catalog – the most complete in the industry.

You may find it helpful first to define your specific needs, and then select a compatible bushing. Standard, off-the-shelf drill bushings are the least expensive. Sometimes, though you may require a special order. Acme will be glad to help you with your toughest requirements.

If you have any questions or need assistance, please call our customer service department at : (847) 428-3911 or (800) 323-5582. Our qualified staff of customer service representatives will be happy to assist you or provide you with the name of the ACME distributor nearest you.

Things to consider in selecting the PROPER drill bushing.

- Use - To drill, tap or ream?
- Kind - Headless, Head, Slip-Fixed Renewable?
- Production Run - Tungsten Carbide or Titanium Nitride Coated bushings, even at a slightly higher cost than standard steel, will last longer during long production runs.
- Size - Hole size, O.D. size, and length.
- Special Requirements - Threaded O.D., angles, flats on head, other special dimensions.
- Standard or Special - Standard sizes are less expensive. Is a special bushing really necessary or will a standard fill your requirement?

No-Counterbore Bushings are Standard with ACME

Acme is committed to the concept of manufacturing our bushings without a counterbore. We believe this produces a better, longer lasting and more versatile bushing (especially if you require modified or special bushings). Even though No-Counterbore bushings are more difficult and costly to produce, because close tolerances are required the full length of the bushing, **No-Counterbore Bushings Are Standard With ACME!** Counterbored bushings will be supplied only upon special request.

Headless Press Fit Bushings

ANSI/ACME Designation Type P

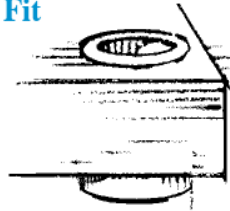

- Most popular, therefore, least expensive
- Typically for single stage drilling operations
- Permits close spacing
- Mounts flush with top of jig plate
- Available with finish ground O.D. or unground for custom grinding

Head Press Fit Bushings

ANSI/ACME Designation Type H

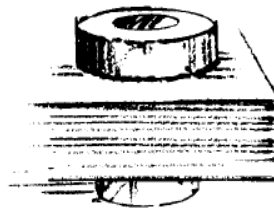

- Same as Headless Press Fit but with head (or shoulder) on the drill entry end
- Head prevents heavy axial loads from forcing bushing through jig hole
- Available with finish ground O.D. or unground for custom grinding
- Flush mounting is possible by counterboring jig hole to fit bushing head

Slip-Fixed Renewable Bushings

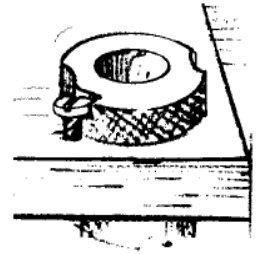

ANSI/ACME Designation Type SF

- The “Two-in-One” Bushing: Fixed mode and slip position options on one knurled head! – flexibility lowers your inventory costs
- Knurled head for easier handling – just turn and lift!
- Used with liner, permanently pressed into drill jig
- Fixed mode for runs longer than life of bushing. Held in place by lock screw or clamp which fits a milled recess in the head.
- Slip mode for multiple operations on the same holes (such as drilling followed by reaming) – without disturbing the workpiece.
- O.D. has a slip fit tolerance for easy insertion or removal from the liner

Headless Press Fit Liners

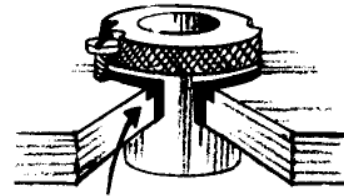

ANSI/ACME Designation Type L

- Used with Slip-Fixed Renewable bushings to provide precise location point
- Permits interchange of Type SF bushings with varied I.D.'s – without affecting center-line accuracy
- Permanently pressed into jig plate – for life of the jig



SELECTION TIPS

- Protects jig plate hole from wear caused by frequent bushing replacement
- Used where little impact will occur on the SF bushing's head

Head Press Fit Liners

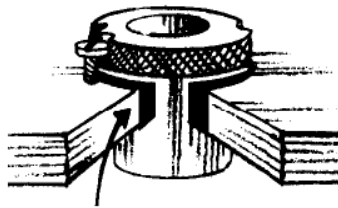

ANSI/ACME Designation Type HL

- Similar to Headless Press Fit Liners but with head or shoulder
- Use with Slip-Fixed Renewable bushings whenever excessive pounding will occur during operation
- Head prevents liner from being pushed through jig
- Flush mount by counterboring top of hole in jig plate
- Available with finish ground O.D. or unground for custom grinding

Oil Groove Bushings

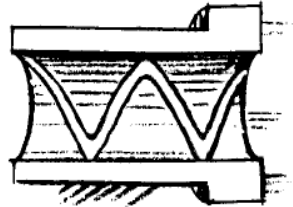

ACME Designation Type OG

- Used for drill lubrication or as a bearing
- Lubricant (or coolant) flows through grooves in bushing I.D. wall
- 25 Oil Groove styles available – headless or with heads
- Wiper designs available to help guard against dirt or chips
- NOTE: The oil groove should not break out the wiper end of the bushing

Extended Range Bushings and Liners

- Sizes larger than ANSI or ACME standards
- Available in types P, H, SF, L and HL
- Unground O.D.'s available for custom grinding

Extra-Thinwall Bushings

- Reduced wall thickness and head diameters save space
- As durable as regular wall thickness bushings
- For use where extremely close hole patterns must be accurately drilled
- Available in Type P, H, and SF
- Note: This type of bushing will not necessarily be round in the free state

Embedment Bushings

- Designed specifically for use in soft materials such as aluminum or magnesium
- Can also be used in jigs or fixtures made with laminated fiberglass or castable potting compounds
- Three types available: Diamond Groove, Ser-Groove, and Spline-Lock

Tungsten Carbide Bushings

- Extremely Hard – hardness of 78-80 RC
- Can last up to 50 times longer than conventional steel bushings
- Available in Type CP, CH, and CSF

Titanium Nitride (TiN) Coated Bushings

- Can last up to 40 times longer than conventional steel bushings
- Excellent results where long wearing capabilities are needed but carbide may be too brittle
- Much more cost effective than carbide bushings when larger quantities (can be as low as three pieces depending on size) are involved

Special/Custom Bushings

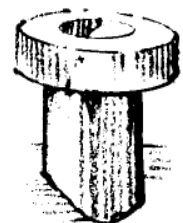
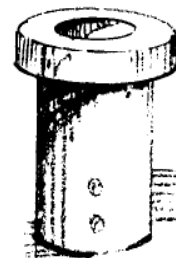

Special Bushings

- Modified Standard - an ANSI/ACME standard bushing is modified or altered in I.D., O.D. or length
- Custom Bushing - Those bushings that can not be easily modified. Requirements can include special diameters, shapes, angles, materials, threads, etc.

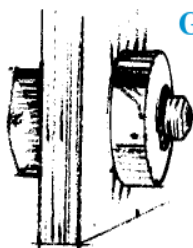

Gun Drill Bushings

ACME Designation Type GD

Gun drills are used where maximum precision for long, deep holes is essential.

- Types GDB and GDX are single piece construction
- The other type of Gun Drill bushing is two piece construction. It consists of a Liner (GDL) and an Insert (GDI). The Insert can be removed from the Liner thus allowing for a range of I.D. sizes using the same Liner
- Acme can manufacture special Gun Drill bushings to fit your exact requirements

Tool Holder Bushings

- Used to adapt various tools to tool holders or turret bores on many types of machine tools
- Available in five different styles and a complete range of sizes
- Special sizes and configurations can be manufactured to meet your exact requirements



Bushing/Liner Installation Tips

(cast iron or unhardened steel jig plates)

Production accuracy requires extra care when preparing mounting holes and installing bushings/liners. The following factors should be considered: diametral interference fits, alignment, chip clearance, and how close the bushing is to the workpiece.

Because of the many variables, no definite rules can substitute for the skill and judgment of the experienced toolmaker. The following suggestions should be helpful to others.

Interference Fits

Interference holds press fit bushings in place on the jig plate. Too much interference may cause a number of problems: (1) jig plate distortion; (2) bellmouthing (bushing/liner walls bow inward); (3) tool seizure, or (4) trouble with slip-fixed renewable fitting into the liner.

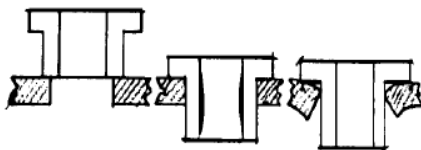

Too little interference may allow slippage, thus causing inaccurately drilled holes. In most cases, interference of 0.0005 to 0.0008 inch is sufficient to properly install press fit bushings and liners.

Mounting Hole Roundness

It is recommended that all mounting holes be jig bored or ground to assure roundness. Ordinary twist drills seldom produce an accurately sized or truly round hole!

Bushing/Liner Installation

First, lubricate the inside diameter of the mounting hole and the outside diameter of the bushing/liner – before pressing into place! Lubrication prevents scoring of the hole wall. White lead is a typical lubricant.

Second, use an arbor press to press the bushing/liner into place. If an arbor press is not available, draw the bushing/liner into place by tightening two steel plates connected by a nut and bolt. A bushing/liner should never be hammered into place! Why defeat the main purpose of the bushing? – Accuracy!

Chip Clearance

One school of thought suggests a space between the workpiece and the drill bushing. The other suggests direct contact. In order to decide, you should consider the abrasiveness of the material being drilled, the drill size, and the type of bushing/liner being applied.

Chips produced from drilling will be ejected either through a space or through the bushing. If your drill clogs or heats up, try increasing the space between the end of the bushing and the workpiece. Normal spaces vary from one-half the drill diameter for small chips (as from cast iron) to one and one-half times the drill diameter for long stringy chips (as from cold-rolled steel).

Vary the length of Slip-Fixed Renewable bushings to achieve proper spacing for your operation (see number 4 below for a more detailed explanation). A rule of thumb is, the greater the space between the bushing and the workpiece, the greater the chance for error. Where possible, test your conditions and continue to check for accuracy throughout your production run.

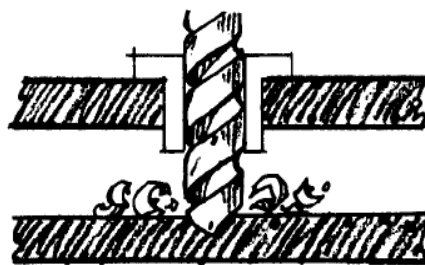

Hints for More Accurate Production and Longer Bushing Life

1) Align Bushings Properly.

Carefully align the drill with the bushing axis to avoid poor alignment and excessive wear. The radius on the bushing will help center the drill point. ACME No-Counterbore bushings help the operator accomplish this with ease.

2) Keep Tools Sharp.

Dull drill bits defeat the preciseness of bushings. Sharpen by first grinding each drill with the point in the exact center. This helps avoid “walking” by the drill when it first enters the workpiece.

3) Use Proper Coolants.

Check the coolant label to be sure you are using the right coolant for your machining process.

4) Use Slip-Fixed Renewable Bushings for Multiple Operations.

Slip-Fixed Renewable Bushings of different lengths provide for both accuracy and chip removal during multiple operations. For example, a short bushing during drilling will provide the proper clearance for chips to escape. A longer bushing during reaming will provide maximum guidance.

5) Adapt Bushings To Irregular Work Surfaces.

The exit end of the bushing should conform to contours of the workpiece. For maximum guidance, hold to a minimum any space for chip clearance. A drill point that does not enter exactly perpendicular to the work surface will skip or wander. In such a case, side load exerted by the drill is concentrated near the exit end of the bushing. The bushing can wear prematurely. Slip-Fixed Renewable bushings could simplify replacement of worn bushings, and also aid alignment with the contoured work surface. For short production runs using press fit bushings, form the bushing end to the workpiece contour.

6) For Long Production Runs, Use Tungsten Carbide or Titanium Nitride Coated Bushings.

ACME Carbide bushings last up to 50 times longer than hardened steel. ACME Titanium Nitride (TiN) coated bushings can last up to 40 times longer than conventional bushings. Both types of bushings could save valuable replacement downtime. The additional cost is small when you consider the extra long life possible. Call us for more details.



SPECIFICATIONS

Bushing Specifications

ANSI/ACME Standard Drill Bushings:

I.D. Range (Std. Drill Size)	Standard I.D. Tolerance (add to nominal I.D.)
#80 to 1/4	+.0001 to +.0004
Over 1/4 to 3/4	+.0001 to +.0005
Over 3/4 to 1-1/2	+.0002 to +.0006
Over 1-1/2 to 2-3/4	+.0003 to +.0007

Reamer Bushings:

I.D. Range (Std. Reamer Size)	I.D. Tolerance (add to nominal I.D.)
Up to 1/4	+.0005 to +.0008
Over 1/4 to 1"	+.0006 to +.0010
Over 1"	+.0008 to +.0012

- Finish Ground bushings, 1/8" to 1" I.D., are held within .0003" concentricity T.I.R. (Total Indicator Reading). Other sizes are held within .0005" T.I.R.
- Unground bushings with .010/.020 grinding stock on the O.D. are concentric within .006". The letter "U" as a suffix to the ANSI symbol indicates an unground O.D. for custom grinding.
- Lengths longer than ANSI Standard or relieved bushings will meet the above tolerances at the drill exit end only.

- Standard and Special bushings will be manufactured from thru-hardened tool steel and heat treated to 61-65 RC unless instructed otherwise by the customer.
- No-Counterbore bushings will be supplied unless requested otherwise. No-Counterbore bushings allow for truer alignment, more accurate holes, less tool wear, and less problems with chips packing up in the I.D. of the bushing. Acme will, however, supply counterbored bushings when requested.
- Specifications for Metric Bushings are in the Standard Metric Bushing Section of this catalog.

Ordering Information

26 pcs.	3/4	P	64	12
Quantity	Inside Diameter	Type	Outside Diameter	Length
	For standard drill sizes show: Fraction, Number, or Letter. For Special I.D.'s indicate decimal size to four places.	Type of Bushing: P = Headless Press Fit H = Head Press Fit SF = Slip-Fixed Renewable L = Headless Liners HL = Head Liners "C" prefix = Tungsten Carbide	O.D. in 64ths of 1" (ie. "64" = 1")	Length in 16ths of 1" (ie. "12" = 3/4") "U" suffix = Unground O.D. for custom grinding

Specify in sequence for each order:

1. Quantity
2. Inside Diameter (Column A in catalog)
3. Type: See Chart above for ANSI/ACME designations
4. Outside Diameter (Column B in catalog)
5. Length (Column C in catalog)
6. Unground O.D.'s specify the Letter "U" after the ANSI Symbol

• Gun Drill Bushings

Specify I.D., Description or Part number (when indicated) and quantity.

• Oil Groove Bushings

Specify in sequence: ACME Oil Groove style, Type of Bushing, I.D., O.D., and length (or ANSI Symbol) and material (steel or bronze). Also indicate style of wiper if required.

• Embedment Bushings

Specify Quantity, I.D. size and ordering symbol.

• Carbide Bushings

Specify Quantity, I.D. and ANSI Symbol prefixed by the letter "C".

• Tool Holder Bushings

Order by Acme Part Number and quantity.



ANSI and Acme Standard Bushings Headless Press Fit



Type P



All press fit bushings are lapped, honed or ground in the I.D. Bushings with I.D.'s of 1/8" to 1" are concentric within .0003" T.I.R. to the O.D. Other I.D. sizes are held within .0005" T.I.R.
No-Counterbore bushings are standard with Acme.

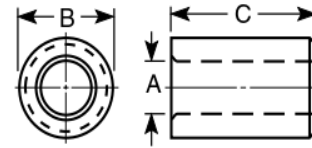

A STANDARD I.D. SIZES		B BODY O.D. Nominal (Actual)	C LENGTH (Overall)	ANSI SYMBOL TYPE P
Number, Letter, or Fraction Size	Range of Dec. Equiv.			
80, 79, 1/64, 78, 77, 76, 75, 74, 73, 72, 71, 70	.0135 to .0280	5/32 (.1578 / .1575)	1/4 5/16 3/8 1/2	P-10-4 P-10-5 P-10-6 P-10-8
69, 68, 1/32, 67, 66, 65, 64, 63, 62, 61, 60, 59, 58, 57, 56, 3/64	.0292 to .0469	5/32 (.1578 / .1575)	1/4 5/16 3/8 1/2 3/4	P-10-4 P-10-5 P-10-6 P-10-8 P-10-12
55, 54, 53, 1/16	.0520 to .0625	5/32 (.1578 / .1575)	1/4 5/16 3/8 1/2 3/4	P-10-4 P-10-5 P-10-6 P-10-8 P-10-12
1/16, 52, 51, 50, 49, 48, 5/64, 47, 46, 45, 44, 43, 42, 3/32, 41, 40, 39	.0625 to .0995	3/16 (.1891 / .1888)	1/4 5/16 3/8 1/2 5/8 3/4	P-12-4 P-12-5 P-12-6 P-12-8 P-12-10 P-12-12
60, 59, 58, 57, 56, 3/64, 55, 54, 53	.0400 to .0595	13/64 (.2046 / .2043)	1/4 5/16 3/8 1/2 3/4	P-13-4 P-13-5 P-13-6 P-13-8 P-13-12
1/16, 52, 51, 50, 49, 48, 5/64, 47, 46, 45, 44, 43, 42, 3/32, 41, 40, 39	.0625 to .0995	13/64 (.2046 / .2043)	1/4 5/16 3/8 1/2 3/4 1 1-3/8	P-13-4 P-13-5 P-13-6 P-13-8 P-13-12 P-13-16 P-13-22
40, 39, 38, 37, 36, 7/64, 35, 34, 33, 32, 31, 1/8, 30, 29, 28, 9/64	.0980 to .1406	1/4 (.2516 / .2513)	1/4 5/16 3/8 1/2 5/8 3/4 1 1-3/8	P-16-4 P-16-5 P-16-6 P-16-8 P-16-10 P-16-12 P-16-16 P-16-22

NOTE: Headless Press Fit Bushings with .010 / .020 rough grinding stock on the O.D. are available, please call for prices. Add the letter "U" to the end of the ANSI Symbol when ordering.



ANSI and Acme Standard Bushings Headless Press Fit

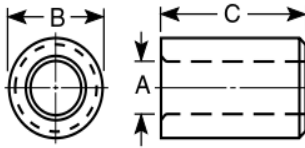

I.D. Range (Drill Size)	Std. I.D. Tolerance (add to nom. I.D.)
#80 to 1/4	+0.0001 to +0.0004
Over 1/4 to 3/4	+0.0001 to +0.0005
Over 3/4 to 1-1/2	+0.0002 to +0.0006
Over 1-1/2 to 2-3/4	+0.0003 to +0.0007

Type P



A STANDARD I.D. SIZES		B BODY O.D. Nominal (Actual)	C LENGTH (Overall)	ANSI SYMBOL TYPE P
Number, Letter, or Fraction Size	Range of Dec. Equiv.			
1/8, 30, 29, 28, 9/64, 27, 26, 25, 24, 23, 5/32, 22, 21, 20, 19, 18, 11/64, 17, 16, 15, 14, 13, 3/16, 12, 11, 10	.1250 to .1935	5/16 (.3141 / .3138)	1/4 5/16 3/8 1/2 5/8 3/4 1 1-3/8	P-20-4 P-20-5 P-20-6 P-20-8 P-20-10 P-20-12 P-20-16 P-20-22
10, 9, 8, 7, 13/64, 6, 5, 4, 3, 7/32, 2, 1	.1935 to .2280	3/8 (.3766 / .3763)	1/4 3/8 1/2 3/4 1	P-24-4 P-24-6 P-24-8 P-24-12 P-24-16
3/16, 12, 11, 10, 9, 8, 7, 13/64, 6, 5, 4, 3, 7/32, 2, 1, A, 15/64, B, C, D, 1/4, F	.1875 to .2570	13/32 (.4078 / .4075)	1/4 5/16 3/8 1/2 3/4 1 1-3/8 1-3/4	P-26-4 P-26-5 P-26-6 P-26-8 P-26-12 P-26-16 P-26-22 P-26-28
15/64, 1/4, F, 17/64, 9/32	.2344 .2500 .2570 2656 .2812	7/16 (.4392 / .4389)	1/4 5/16 3/8 1/2 5/8 3/4 1	P-28-4 P-28-5 P-28-6 P-28-8 P-28-10 P-28-12 P-28-16
3/16, 12, 11, 10, 9, 8, 7, 13/64, 6, 5, 4, 3, 7/32, 2, 1, A, 15/64, B, C, D, 1/4, F, G, 17/64, H, I, J, K, 9/32, L, M, 19/64, N, 5/16, O	.1875 to .3160	1/2 (.5017 / .5014)	5/16 3/8 1/2 3/4 1 1-3/8 1-3/4	P-32-5 P-32-6 P-32-8 P-32-12 P-32-16 P-32-22 P-32-28
N, 5/16, O, P, 21/64, Q, R, 11/32	.3020 to .3438	9/16 (.5642 / .5639)	3/8 1/2 3/4 1	P-36-6 P-36-8 P-36-12 P-36-16

NOTE: Headless Press Fit Bushings with .010 / .020 rough grinding stock on the O.D. are available, please call for prices. Add the letter "U" to the end of the ANSI Symbol when ordering.

See Headless Liner section for additional lengths on some specific I.D. sizes of Type "P" Bushings.

No-Counterbore (Full Bearing Surface) Bushings are Standard at ACME.

ANSI and Acme Standard Bushings Headless Press Fit



Type P



All press fit bushings are lapped, honed or ground in the I.D. Bushings with I.D.'s of 1/8" to 1" are concentric within .0003" T.I.R. to the O.D. Other I.D. sizes are held within .0005" T.I.R.
No-Counterbore bushings are standard with Acme.

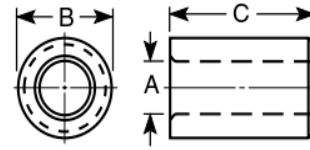

A STANDARD I.D. SIZES		B BODY O.D. Nominal (Actual)	C LENGTH (Overall)	ANSI SYMBOL TYPE P
Number, Letter, or Fraction Size	Range of Dec. Equiv.			
5/16, O, P, 21/64, Q, R, 11/32, S, T, 23/64, U, 3/8, V, W, 25/64, X, Y, 13/32, Z, 27/64, 7/16	.3125 to .4375	5/8 (.6267 / .6264)	5/16 3/8 1/2 5/8 3/4 1 1-1/4 1-3/8 1-3/4 2-1/8	P-40-5 P-40-6 P-40-8 P-40-10 P-40-12 P-40-16 P-40-20 P-40-22 P-40-28 P-40-34
5/16, O, P, 21/64, Q, R, 11/32, S, T, 23/64, U, 3/8, V, W, 25/64, X, Y, 13/32, Z, 27/64, 7/16, 29/64, 15/32, 31/64, 1/2, 33/64, 17/32	.3125 to .5312	3/4 (.7518 / .7515)	3/8 1/2 5/8 3/4 1 1-1/4 1-3/8 1-3/4 2-1/8 2-1/2	P-48-6 P-48-8 P-48-10 P-48-12 P-48-16 P-48-20 P-48-22 P-48-28 P-48-34 P-48-40
1/2, 33/64, 17/32, 35/64, 9/16, 37/64, 19/32, 39/64, 5/8, 41/64, 21/32	.5000 to .6562	7/8 (.8768 / .8765)	1/2 5/8 3/4 1 1-1/4 1-3/8 1-1/2 1-3/4 2-1/8 2-1/2	P-56-8 P-56-10 P-56-12 P-56-16 P-56-20 P-56-22 P-56-24 P-56-28 P-56-34 P-56-40
1/2, 33/64, 17/32, 35/64, 9/16, 37/64, 19/32, 39/64, 5/8, 41/64, 21/32, 43/64, 11/16, 45/64, 23/32, 47/64, 3/4, 49/64	.5000 to .7656	1 (1.0018 / 1.0015)	1/2 5/8 3/4 1 1-1/4 1-3/8 1-1/2 1-3/4 2-1/8 2-1/2 3	P-64-8 P-64-10 P-64-12 P-64-16 P-64-20 P-64-22 P-64-24 P-64-28 P-64-34 P-64-40 P-64-48

NOTE: Headless Press Fit Bushings with .010 / .020 rough grinding stock on the O.D. are available, please call for prices. Add the letter "U" to the end of the ANSI Symbol when ordering.

See Headless Liner section for additional lengths on some specific I.D. sizes of Type "P" Bushings.

No-Counterbore (Full Bearing Surface) Bushings are Standard at ACME.



ANSI and Acme Standard Bushings Headless Press Fit

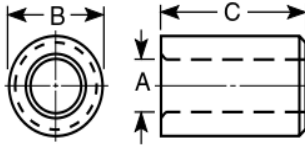

I.D. Range (Drill Size)	Std. I.D. Tolerance (add to nom. I.D.)
#80 to 1/4	+0.0001 to +0.0004
Over 1/4 to 3/4	+0.0001 to +0.0005
Over 3/4 to 1-1/2	+0.0002 to +0.0006
Over 1-1/2 to 2-3/4	+0.0003 to +0.0007

Type P



A STANDARD I.D. SIZES		B BODY O.D. Nominal (Actual)	C LENGTH (Overall)	ANSI SYMBOL TYPE P
Number, Letter, or Fraction Size	Range of Dec. Equiv.			
25/32, 13/16, 27/32	.7812 .8125 .8438	1-1/8 (1.1270 / 1.1267)	1/2 3/4 1	P-72-8 P-72-12 P-72-16
7/8 and 15/16	.8750 & .9375	1-1/4 (1.2520/ 1.2517)	5/8 3/4 1 1-1/4 1-1/2 1-3/4 2	P-80-10 P-80-12 P-80-16 P-80-20 P-80-24 P-80-28 P-80-32
3/4, 49/64, 25/32, 51/64, 13/16, 53/64, 27/32, 55/64, 7/8, 57/64, 29/32, 59/64, 15/16, 61/64, 31/32, 63/64, 1", 1-1/64, 1-1/32	.7500 to 1.0312	1-3/8 (1.3772 / 1.3768)	1/2 3/4 1 1-1/4 1-3/8 1-1/2 1-3/4 2 2-1/8 2-1/2 3	P-88-8 P-88-12 P-88-16 P-88-20 P-88-22 P-88-24 P-88-28 P-88-32 P-88-34 P-88-40 P-88-48
1-1/32, 1-1/16, 1-3/32, 1-1/8	1.0312 1.0625 1.0938 1.1250	1-1/2 (1.5022 / 1.5018)	3/4 1 1-1/4 1-1/2 1-3/4 2	P-96-12 P-96-16 P-96-20 P-96-24 P-96-28 P-96-32
1", 1-1/64, 1-1/32, 1-3/64, 1-1/16, 1-5/64, 1-3/32, 1-7/64, 1-1/8, 1-9/64, 1-5/32, 1-11/64, 1-3/16, 1-13/64, 1-7/32, 1-15/64, 1-1/4, 1-17/64, 1-9/32, 1-19/64, 1-5/16, 1-21/64, 1-11/32, 1-23/64, 1-3/8, 1-25/64	1.0000 to 1.3906	1-3/4 (1.7523 / 1.7519)	3/4 1 1-3/8 1-3/4 2-1/8 2-1/2 3	P-112-12 P-112-16 P-112-22 P-112-28 P-112-34 P-112-40 P-112-48
1-3/8, 1-25/64, 1-13/32, 1-27/64, 1-7/16, 1-29/64, 1-15/32, 1-31/64, 1-1/2, 1-33/64, 1-17/32, 1-35/64, 1-9/16, 1-37/64, 1-19/32, 1-39/64, 1-5/8, 1-41/64, 1-21/32, 1-43/64, 1-11/16, 1-45/64, 1-23/32, 1-47/64, 1-3/4	1.3750 to 1.7500	2-1/4 (2.2525 / 2.2521)	1 1-3/8 1-3/4 2-1/8 2-1/2 3	P-144-16 P-144-22 P-144-28 P-144-34 P-144-40 P-144-48

NOTE: Headless Press Fit Bushings with .010 / .020 rough grinding stock on the O.D. are available, please call for prices. Add the letter "U" to the end of the ANSI Symbol when ordering.

See Headless Liner section for additional lengths on some specific I.D. sizes of Type "P" Bushings.



ANSI and Acme Standard Bushings Head Press Fit



Type H



All press fit bushings are lapped, honed or ground in the I.D. Bushings with I.D.'s of 1/8" to 1" are concentric within .0003" T.I.R. to the O.D. Other I.D. sizes are held within .0005" T.I.R.
No-Counterbore bushings are standard with Acme.

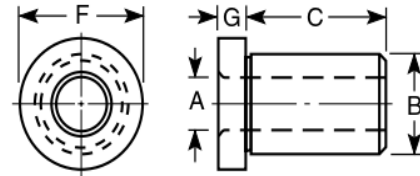

A STANDARD I.D. SIZES		B BODY O.D. Nominal (Actual)	C LENGTH (Under Head)	ANSI SYMBOL TYPE H	F Head Dia.	G Head Thick.
Number, Letter, or Fraction Size	Range of Dec. Equiv.					
80, 79, 1/64, 78, 77, 76, 75, 74, 73, 72, 71, 70	.0135 to .0280	5/32 (.1578 / .1575)	1/4 5/16 3/8 1/2	H-10-4 H-10-5 H-10-6 H-10-8	1/4	3/32
69, 68, 1/32, 67, 66, 65, 64, 63, 62, 61, 60, 59, 58, 57, 56, 3/64	.0292 to .0469	5/32 (.1578 / .1575)	1/4 5/16 3/8 1/2	H-10-4 H-10-5 H-10-6 H-10-8	1/4	3/32
55, 54, 53, 1/16	.0520 to .0625	5/32 (.1578 / .1575)	1/4 5/16 3/8 1/2	H-10-4 H-10-5 H-10-6 H-10-8	1/4	3/32
1/16, 52, 51, 50, 49, 48, 5/64, 47, 46, 45, 44, 43, 42, 3/32, 41, 40, 39	.0625 to .0995	3/16 (.1891 / .1888)	1/4 5/16 3/8 1/2 3/4	H-12-4 H-12-5 H-12-6 H-12-8 H-12-12	5/16	3/32
60, 59, 58, 57, 56, 3/64, 55, 54, 53	.0400 to .0595	13/64 (.2046 / .2043)	1/4 5/16 3/8 1/2 3/4	H-13-4 H-13-5 H-13-6 H-13-8 H-13-12	19/64	3/32
1/16, 52, 51, 50, 49, 48, 5/64, 47, 46, 45, 44, 43, 42, 3/32, 41, 40, 39	.0625 to .0995	13/64 (.2046 / .2043)	1/4 5/16 3/8 1/2 3/4 1	H-13-4 H-13-5 H-13-6 H-13-8 H-13-12 H-13-16	19/64	3/32
40, 39, 38, 37, 36, 7/64, 35, 34, 33, 32, 31, 1/8, 30, 29, 28, 9/64	.0980 to .1406	1/4 (.2516 / .2513)	1/4 5/16 3/8 1/2 5/8 3/4 1 1-3/8	H-16-4 H-16-5 H-16-6 H-16-8 H-16-10 H-16-12 H-16-16 H-16-22	23/64	3/32

NOTE: Head Press Fit Bushings with .010 / .020 rough grinding stock on the O.D. are available, please call for prices. Add the letter "U" to the end of the ANSI Symbol when ordering.

No-Counterbore (Full Bearing Surface) Bushings are Standard at ACME



ANSI and Acme Standard Bushings Head Press Fit

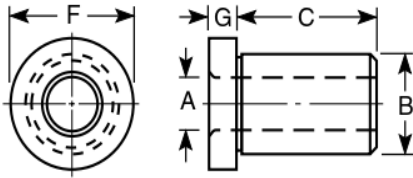

I.D. Range (Drill Size)	Standard I.D. Tolerance (add to nominal I.D.)
#80 to 1/4	+.0001 to +.0004
Over 1/4 to 3/4	+.0001 to +.0005
Over 3/4 to 1-1/2	+.0002 to +.0006
Over 1-1/2 to 2-3/4	+.0003 to +.0007

Type H



STANDARD I.D. SIZES		B BODY O.D. Nominal (Actual)	C LENGTH (Under Head)	ANSI SYMBOL TYPE H	F Head Dia.	G Head Thick.
Number, Letter, or Fraction Size	Range of Dec. Equiv.					
1/8, 30, 29, 28, 9/64, 27, 26, 25, 24, 23, 5/32, 22, 21, 20, 19, 18, 11/64, 17, 16, 15, 14, 13, 3/16, 12, 11, 10	.1250 to .1935	5/16 (.3141 / .3138)	1/4 5/16 3/8 1/2 5/8 3/4 1 1-3/8 1-3/4	H-20-4 H-20-5 H-20-6 H-20-8 H-20-10 H-20-12 H-20-16 H-20-22 H-20-28	27/64	1/8
10, 9, 8, 7, 13/64, 6, 5, 4, 3, 7/32, 2, 1	.1935 to .2280	3/8 (.3766 / .3763)	1/4 3/8 1/2 3/4 1	H-24-4 H-24-6 H-24-8 H-24-12 H-24-16	1/2	3/32
3/16, 12, 11, 10, 9, 8, 7, 13/64, 6, 5, 4, 3, 7/32, 2, 1, A, 15/64, B, C, D, 1/4, F	.1875 to .2570	13/32 (.4078 / .4075)	1/4 5/16 3/8 1/2 3/4 1 1-3/8 1-3/4	H-26-4 H-26-5 H-26-6 H-26-8 H-26-12 H-26-16 H-26-22 H-26-28	1/2	5/32
15/64, 1/4, F, 17/64, 9/32	.2344 .2500 .2570 .2656 .2812	7/16 (.4392 / .4389)	1/4 3/8 1/2 5/8 3/4 1	H-28-4 H-28-6 H-28-8 H-28-10 H-28-12 H-28-16	9/16	3/32
3/16, 12, 11, 10, 9, 8, 7, 13/64, 6, 5, 4, 3, 7/32, 2, 1, A, 15/64, B, C, D, 1/4, F, G, 17/64, H, I, J, K, 9/32, L, M, 19/64, N, 5/16, O	.1875 to .3160	1/2 (.5017 / .5014)	1/4 5/16 3/8 1/2 3/4 1 1-3/8 1-3/4	H-32-4 H-32-5 H-32-6 H-32-8 H-32-12 H-32-16 H-32-22 H-32-28	39/64	7/32
N, 5/16, O, P, 21/64, Q, R, 11/32	.3020 to .3438	9/16 (.5642 / .5639)	3/8 1/2 5/8 3/4 1	H-36-6 H-36-8 H-36-10 H-36-12 H-36-16	11/16	3/32

NOTE: Head Press Fit Bushings with .010 / .020 rough grinding stock on the O.D. are available, please call for prices. Add the letter "U" to the end of the ANSI Symbol when ordering.



ANSI and Acme Standard Bushings Head Press Fit



Type H



All press fit bushings are lapped, honed or ground in the I.D. Bushings with I.D.'s of 1/8" to 1" are concentric within .0003" T.I.R. to the O.D. Other I.D. sizes are held within .0005" T.I.R.
No-Counterbore bushings are standard with Acme.

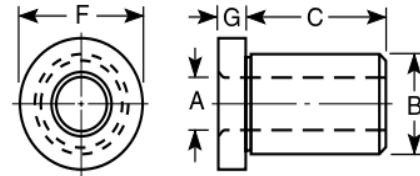

A STANDARD I.D. SIZES		B BODY O.D. Nominal (Actual)	C LENGTH (Under Head)	ANSI SYMBOL TYPE H	F Head Dia.	G Head Thick.
Number, Letter, or Fraction Size	Range of Dec. Equiv.					
5/16, O, P, 21/64, Q, R, 11/32, S, T, 23/64, U, 3/8, V, W, 25/64, X, Y, 13/32, Z, 27/64, 7/16	.3125 to .4375	5/8 (.6267 / .6264)	1/4 5/16 3/8 1/2 5/8 3/4 1 1-3/8 1-3/4 2-1/8	H-40-4 H-40-5 H-40-6 H-40-8 H-40-10 H-40-12 H-40-16 H-40-22 H-40-28 H-40-34	51/64	7/32
5/16, O, P, 21/64, Q, R, 11/32, S, T, 23/64, U, 3/8, V, W, 25/64, X, Y, 13/32, Z, 27/64, 7/16, 29/64, 15/32, 31/64, 1/2, 33/64, 17/32	.3125 to .5312	3/4 (.7518 / .7515)	1/4 3/8 1/2 5/8 3/4 1 1-1/4 1-3/8 1-3/4 2-1/8 2-1/2	H-48-4 H-48-6 H-48-8 H-48-10 H-48-12 H-48-16 H-48-20 H-48-22 H-48-28 H-48-34 H-48-40	59/64	7/32
1/2, 33/64, 17/32, 35/64, 9/16, 37/64, 19/32, 39/64, 5/8, 41/64, 21/32	.5000 to .6562	7/8 (.8768 / .8765)	3/8 1/2 5/8 3/4 1 1-1/4 1-3/8 1-1/2 1-3/4 2-1/8 2-1/2	H-56-6 H-56-8 H-56-10 H-56-12 H-56-16 H-56-20 H-56-22 H-56-24 H-56-28 H-56-34 H-56-40	1-7/64	1/4
1/2, 33/64, 17/32, 35/64, 9/16, 37/64, 19/32, 39/64, 5/8, 41/64, 21/32, 43/64, 11/16, 45/64, 23/32, 47/64, 3/4, 49/64	.5000 to .7656	1 (1.0018 / 1.0015)	1/2 3/4 1 1-3/8 1-1/2 1-3/4 2-1/8 2-1/2 3	H-64-8 H-64-12 H-64-16 H-64-22 H-64-24 H-64-28 H-64-34 H-64-40 H-64-48	1-15/64	5/16

NOTE: Head Press Fit Bushings with .010 / .020 rough grinding stock on the O.D. are available, please call for prices. Add the letter "U" to the end of the ANSI Symbol when ordering.



ANSI and Acme Standard Bushings Head Press Fit

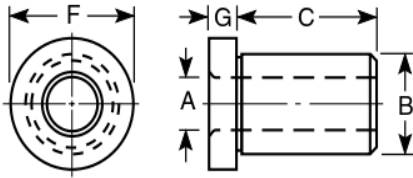

I.D. Range (Drill Size)	Standard I.D. Tolerance (add to nominal I.D.)
#80 to 1/4	+ .0001 to +.0004
Over 1/4 to 3/4	+ .0001 to +.0005
Over 3/4 to 1-1/2	+ .0002 to +.0006
Over 1-1/2 to 2-3/4	+ .0003 to +.0007

Type H



A STANDARD I.D. SIZES		B BODY O.D. Nominal (Actual)	C LENGTH (Under Head)	ANSI SYMBOL TYPE H	F Head Dia.	G Head Thick.
Number, Letter, or Fraction Size	Range of Dec. Equiv.					
7/8 and 15/16	.8750 & .9375	1-1/4 (1.2520 / 1.2517)	5/8 3/4 1 1-1/4 1-1/2 1-3/4 2	H-80-10 H-80-12 H-80-16 H-80-20 H-80-24 H-80-28 H-80-32	1-1/2	1/4
3/4, 49/64, 25/32, 51/64, 13/16, 53/64, 27/32, 55/64, 7/8, 57/64, 29/32, 59/64, 15/16, 61/64, 31/32, 63/64, 1", 1-1/64, 1-1/32	.7500 to 1.0312	1-3/8 (1.3772 / 1.3768)	1/2 3/4 1 1-3/8 1-1/2 1-3/4 2-1/8 2-1/2 3	H-88-8 H-88-12 H-88-16 H-88-22 H-88-24 H-88-28 H-88-34 H-88-40 H-88-48	1-39/64	3/8
1", 1-1/64, 1-1/32, 1-3/64, 1-1/16, 1-5/64, 1-3/32, 1-7/64, 1-1/8, 1-9/64, 1-5/32, 1-11/64, 1-3/16, 1-13/64, 1-7/32, 1-15/64, 1-1/4, 1-17/64, 1-9/32, 1-19/64, 1-5/16, 1-21/64, 1-11/32, 1-23/64, 1-3/8, 1-25/64	1.0000 to 1.3906	1-3/4 (1.7523 / 1.7519)	3/4 1 1-3/8 1-3/4 2-1/8 2-1/2 3	H-112-12 H-112-16 H-112-22 H-112-28 H-112-34 H-112-40 H-112-48	1-63/64	3/8
1-3/8, 1-25/64, 1-13/32, 1-27/64, 1-7/16, 1-29/64, 1-15/32, 1-31/64, 1-1/2, 1-33/64, 1-17/32, 1-35/64, 1-9/16, 1-37/64, 1-19/32, 1-39/64, 1-5/8, 1-41/64, 1-21/32, 1-43/64, 1-11/16, 1-45/64, 1-23/32, 1-47/64, 1-3/4	1.3750 to 1.7500	2-1/4 (2.2525 / 2.2521)	1 1-3/8 1-3/4 2-1/8 2-1/2 3	H-144-16 H-144-22 H-144-28 H-144-34 H-144-40 H-144-48	2-31/64	3/8

NOTE: Head Press Fit Bushings with .010 / .020 rough grinding stock on the O.D. are available, please call for prices. Add the letter "U" to the end of the ANSI Symbol when ordering.

No-Counterbore (Full Bearing Surface) Bushings are Standard at ACME

ANSI and Acme Standard Bushings

Slip-Fixed Renewable



Type SF



All type "SF" bushings are lapped, honed or ground in the I.D. Bushings with I.D.'s of 1/8" to 1" are concentric within .0003" T.I.R. to the O.D. Other I.D. sizes are held within .0005" T.I.R. A slip fit clearance is provided for proper alignment when inserted into a liner.

No-Counterbore bushings are standard with Acme.

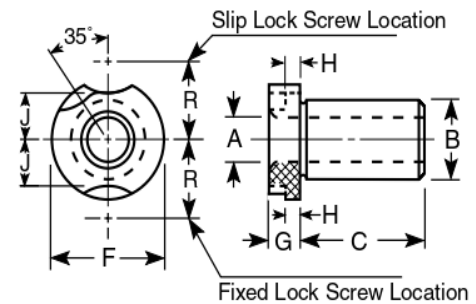

A STANDARD I.D. SIZES		B BODY O.D. Nominal (Actual)	C LENGTH (Under Head)	ANSI SYMBOL Type SF	HEAD SIZE		LOCK SCREWS AND CLAMPS
Number, Letter, or Fraction Size	Range of Dec. Equiv.				Head Dim.	Lockscrew Location	
80, 79, 1/64, 78, 77, 76, 75, 74, 73, 72, 71, 70	.0135 to .0280	3/16 (.1875 / .1873)	1/4 5/16 3/8 1/2	SF-12-4 SF-12-5 SF-12-6 SF-12-8	F = 5/16 G = 3/16	H = 3/32 J = 3/32 R = 17/64	#1 - LS
69, 68, 1/32, 67, 66, 65, 64, 63, 62, 61, 60, 59, 58, 57, 56, 3/64	.0292 to .0469	3/16 (.1875 / .1873)	1/4 5/16 3/8 1/2	SF-12-4 SF-12-5 SF-12-6 SF-12-8	F = 5/16 G = 3/16	H = 3/32 J = 3/32 R = 17/64	#1 - LS
55, 54, 53	.0520 to .0595	3/16 (.1875 / .1873)	1/4 5/16 3/8 1/2	SF-12-4 SF-12-5 SF-12-6 SF-12-8	F = 5/16 G = 3/16	H = 3/32 J = 3/32 R = 17/64	#1-LS
1/16, 52, 51, 50, 49, 48, 5/64, 47, 46, 45, 44, 43, 42, 3/32, 41, 40	.0625 to .0980	3/16 (.1875 / .1873)	1/4 5/16 3/8 1/2 3/4	SF-12-4 SF-12-5 SF-12-6 SF-12-8 SF-12-12	F = 5/16 G = 3/16	H = 3/32 J = 3/32 R = 17/64	#1-LS
39, 38, 37, 36, 7/64, 35, 34, 33, 32, 31, 1/8, 30, 29, 28	.0995 to .1405	1/4 (.2500 / .2498)	1/4 3/8 1/2 5/8 3/4	SF-16-4 SF-16-6 SF-16-8 SF-16-10 SF-16-12	F = 7/16 G = 1/4	H = 1/8 J = 9/64 R = 23/64	#2 - LS
3/64, 55, 54, 53	.0469 to .0595	5/16 (.3125 / .3123)	5/16 3/8 1/2 3/4 1	SF-20-5 SF-20-6 SF-20-8 SF-20-12 SF-20-16	F = 35/64 G = 1/4	H = 1/8 J = 11/64 R = 1/2	1A - LS RC - 1A
1/16, 52, 51, 50, 49, 48, 5/64, 47, 46, 45, 44, 43	.0625 to .0890	5/16 (.3125 / .3123)	5/16 3/8 1/2 3/4 1	SF-20-5 SF-20-6 SF-20-8 SF-20-12 SF-20-16	F = 35/64 G = 1/4	H = 1/8 J = 11/64 R = 1/2	1A - LS RC - 1A
42, 3/32, 41, 40, 39, 38, 37, 36, 7/64, 35, 34, 33, 32, 31, 1/8, 30, 29, 28, 9/64, 27, 26, 25, 24, 23, 5/32, 22, 21, 20, 19, 18, 11/64, 17, 16, 15, 14, 13, 3/16, 12, 11, 10	.0935 to .1935	5/16 (.3125 / .3123)	5/16 3/8 1/2 3/4 1 1-3/8	SF-20-5 SF-20-6 SF-20-8 SF-20-12 SF-20-16 SF-20-22	F = 35/64 G = 1/4	H = 1/8 J = 11/64 R = 1/2	1A - LS RC - 1A
10, 9, 8, 7, 13/64, 6, 5, 4, 3, 7/32, 2, 1	.1935 to .2280	3/8 (.3750 / .3748)	1/4 3/8 1/2 3/4 1	SF-24-4 SF-24-6 SF-24-8 SF-24-12 SF-24-16	F = 5/8 G = 1/4	H = 1/8 J = 15/64 R = 29/64	#2 - LS



ANSI and Acme Standard Bushings Slip-Fixed Renewable

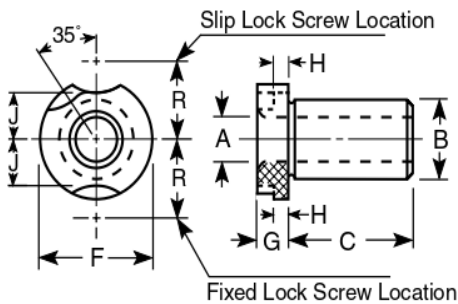

I.D. Range (Drill Size)	Standard I.D. Tolerance (add to nominal I.D.)
#80 to 1/4	+ .0001 to +.0004
Over 1/4 to 3/4	+ .0001 to +.0005
Over 3/4 to 1-1/2	+ .0002 to +.0006
Over 1-1/2 to 2-3/4	+ .0003 to +.0007

Type SF



STANDARD I.D. SIZES		B BODY O.D. Nominal (Actual)	C LENGTH (Under Head)	ANSI SYMBOL Type SF	HEAD SIZE		LOCK SCREWS AND CLAMPS
Number, Letter, or Fraction Size	Range of Dec. Equiv.				Head Dim.	Lockscrew Location	
15/64, 1/4, F, 17/64, 9/32	.2344 to .2500 to .2570 to .2656 to .2812	7/16 (.4375 / .4373)	3/8 1/2 3/4 1	SF-28-6 SF-28-8 SF-28-12 SF-28-16	F = 5/8 G = 1/4	H = 1/8 J = 15/64 R = 29/64	#2 - LS
9/64, 27, 26, 25, 24, 23, 5/32, 22, 21, 20, 19, 18, 11/64, 17, 16, 15, 14, 13, 3/16	.1406 to .1875	1/2 (.5000 / .4998)	5/16 3/8 1/2 3/4 1 1-3/8 1-3/4	SF-32-5 SF-32-6 SF-32-8 SF-32-12 SF-32-16 SF-32-22 SF-32-28	F = 51/64 G = 1/4	H = 1/8 J = 19/64 R = 5/8	1A - LS RC - 1A
12, 11, 10, 9, 8, 7, 13/64, 6, 5, 4, 3, 7/32, 2, 1, A, 15/64, B, C, D, 1/4, F, G, 17/64, H, I, J, K, 9/32, L, M, 19/64, N, 5/16, O, P, 21/64, Q, R, 11/32	.1890 to .3438	1/2 (.5000 / .4998)	5/16 3/8 1/2 3/4 1 1-3/8 1-3/4 2-1/8	SF-32-5 SF-32-6 SF-32-8 SF-32-12 SF-32-16 SF-32-22 SF-32-28 SF-32-34	F = 51/64 G = 1/4	H = 1/8 J = 19/64 R = 5/8	1A-LS RC - 1A
5/16, O, P, 21/64, Q, R, 11/32	.3125 to .3438	9/16 (.5625 / .5623)	1/2 5/8 3/4 1	SF-36-8 SF-36-10 SF-36-12 SF-36-16	F = 7/8 G = 1/4	H = 1/8 J = 23/64 R = 37/64	#2 - LS
23/64, U, 3/8, V, W, 25/64, X, Y, 13/32, Z, 27/64, 7/16	.3594 to .4375	5/8 (.6250 / .6248)	5/16 3/8 1/2 5/8 3/4 1 1-1/4	SF-40-5 SF-40-6 SF-40-8 SF-40-10 SF-40-12 SF-40-16 SF-40-20	F = 7/8 G = 1/4	H = 1/8 J = 23/64 R = 37/64	#2 - LS
9/32, L, M, 19/64, N, 5/16, O, P, 21/64, Q, R, 11/32, S, T, 23/64, U, 3/8, V, W, 25/64, X, Y, 13/32, Z, 27/64, 7/16, 29/64, 15/32, 31/64, 1/2, 33/64, 17/32, 35/64, 9/16	.2812 to .5625	3/4 (.7500 / .7498)	1/2 3/4 1 1-3/8 1-3/4 2-1/8 2-1/2 3	SF-48-8 SF-48-12 SF-48-16 SF-48-22 SF-48-28 SF-48-34 SF-48-40 SF-48-48	F = 1-3/64 G = 1/4	H = 1/8 J = 27/64 R = 3/4	1A - LS RC - 1A

“SF” bushings are available milled for flat clamps. To order please prefix the letters “FM”.

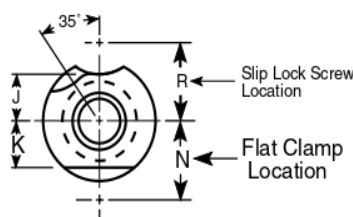

Body O.D.	“K”	“N”	Use Clamp
5/16	11/64	11/16	FC-1
1/2	17/64	25/32	FC-1
3/4	25/64	57/64	FC-1
1	1/2	1-9/64	FC-2
1-3/8	11/16	1-21/64	FC-2
1-3/4	7/8	1-33/64	FC-3
2-1/4	1-1/8	1-49/64	FC-3



ANSI and Acme Standard Bushings

Slip-Fixed Renewable



Type SF



All type "SF" bushings are lapped, honed or ground in the I.D. Bushings with I.D.'s of 1/8" to 1" are concentric within .0003" T.I.R. to the O.D. Other I.D. sizes are held within .0005" T.I.R. A slip fit clearance is provided for proper alignment when inserted into a liner.
No-Counterbore bushings are standard with Acme.

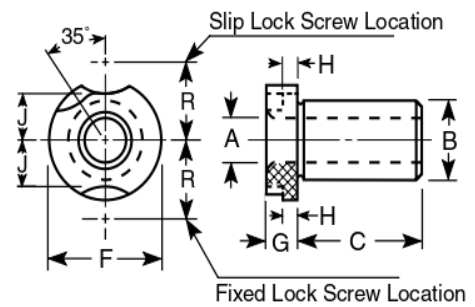

A STANDARD I.D. SIZES		B BODY O.D. Nominal (Actual)	C LENGTH (Under Head)	ANSI SYMBOL Type SF	HEAD SIZE		LOCK SCREWS AND CLAMPS
Number, Letter, or Fraction Size	Range of Dec. Equiv.				Head Dim.	Lockscrew Location	
35/64, 9/16, 37/64, 19/32, 39/64, 5/8, 41/64, 21/32	.5469 to .6562	7/8 (.8750 / .8748)	1/2 3/4 1 1-1/4 1-1/2	SF-56-8 SF-56-12 SF-56-16 SF-56-20 SF-56-24	F = 1-1/4 G = 3/8	H = 3/16 J = 31/64 R = 53/64	2A - LS RC - 2A
15/32, 31/64, 1/2, 33/64, 17/32, 35/64, 9/16, 37/64, 19/32, 39/64, 5/8, 41/64, 21/32, 43/64, 11/16, 45/64, 23/32, 47/64, 3/4, 49/64, 25/32	.4688 to .7812	1" (1.0000 / .9998)	1/2 3/4 1 1-3/8 1-1/2 1-3/4 2-1/8 2-1/2 3	SF-64-8 SF-64-12 SF-64-16 SF-64-22 SF-64-24 SF-64-28 SF-64-34 SF-64-40 SF-64-48	F = 1-27/64 G = 3/8	H = 3/16 J = 19/32 R = 59/64	2A - LS RC - 2A
7/8 & 15/16	.8750 & .9375	1-1/4 (1.2500 / 1.2498)	3/4 1 1-1/4 2	SF-80-12 SF-80-16 SF-80-20 SF-80-32	F = 1-5/8 G = 3/8	H = 3/16 J = 43/64 R = 1-1/64	2A - LS RC - 2A
3/4, 49/64, 25/32, 51/64, 13/16, 53/64, 27/32, 55/64, 7/8, 57/64, 29/32, 59/64, 15/16, 61/64, 31/32, 63/64, 1", 1-1/64, 1-1/32, 1-3/64, 1-1/16	.7500 to 1.0625	1-3/8 (1.3750 / 1.3747)	3/4 1 1-3/8 1-1/2 1-3/4 2-1/8 2-1/2 3	SF-88-12 SF-88-16 SF-88-22 SF-88-24 SF-88-28 SF-88-34 SF-88-40 SF-88-48	F = 1-51/64 G = 3/8	H = 3/16 J = 25/32 R = 1-7/64	2A - LS RC - 2A
1", 1-1/64, 1-1/32, 1-3/64, 1-1/16, 1-5/64, 1-3/32, 1-7/64, 1-1/8, 1-9/64, 1-5/32, 1-11/64, 1-3/16, 1-13/64, 1-7/32, 1-15/64, 1-1/4, 1-17/64, 1-9/32, 1-19/64, 1-5/16, 1-21/64, 1-11/32, 1-23/64, 1-3/8	1.0000 to 1.3750	1-3/4 (1.7500 / 1.7497)	3/4 1 1-3/8 1-3/4 2-1/8 2-1/2 3	SF-112-12 SF-112-16 SF-112-22 SF-112-28 SF-112-34 SF-112-40 SF-112-48	F = 2-19/64 G = 3/8	H = 3/16 J = 1" R = 1-25/64	3A - LS RC - 3A
1-3/8, 1-25/64, 1-13/32, 1-27/64, 1-7/16, 1-29/64, 1-15/32, 1-31/64, 1-1/2, 1-33/64, 1-17/32, 1-35/64, 1-9/16, 1-37/64, 1-19/32, 1-39/64, 1-5/8, 1-41/64, 1-21/32, 1-43/64, 1-11/16, 1-45/64, 1-23/32, 1-47/64, 1-3/4	1.3750 to 1.7500	2-1/4 (2.2500 / 2.2496)	1 1-3/8 1-3/4 2-1/8 2-1/2 3	SF-144-16 SF-144-22 SF-144-28 SF-144-34 SF-144-40 SF-144-48	F = 2-51/64 G = 3/8	H = 3/16 J = 1-1/4 R = 1-41/64	3A - LS RC - 3A

Please use the prefix "FM" when ordering "SF" bushings milled for flat clamps.

I.D. Range (Drill Size)	Standard I.D. Tolerance (add to nominal I.D.)
#80 to 1/4	+0.0001 to +0.0004
Over 1/4 to 3/4	+0.0001 to +0.0005
Over 3/4 to 1-1/2	+0.0002 to +0.0006
Over 1-1/2 to 2-3/4	+0.0003 to +0.0007

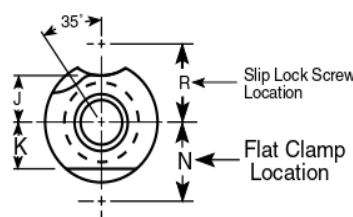

Body O.D.	"K"	"N"	Use Clamp
5/16	11/64	11/16	FC-1
1/2	17/64	25/32	FC-1
3/4	25/64	57/64	FC-1
1	1/2	1-9/64	FC-2
1-3/8	11/16	1-21/64	FC-2
1-3/4	7/8	1-33/64	FC-3
2-1/4	1-1/8	1-49/64	FC-3



ANSI and Acme Standard Bushings Headless Liners

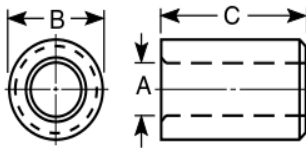

All liner bushings are honed or ground in the I.D. Liners with I.D.'s 3/16" to 1" are concentric within .0003" T.I.R. to the O.D. Other I.D. sizes are held within .0005" T.I.R. All unground bushings are left rough on the O.D. with concentricity of approximately .006" T.I.R.

Type L



A I.D. SIZE		B BODY O.D.			C LENGTH (Overall)	ANSI SYMBOL TYPE L	
Nominal	Actual	Nominal	Actual			Ground	Unground
			Ground	Unground			
3/16	.1876 .1879	5/16	.3141 .3138	.327 .322	1/4	L-20-4	L-20-4U
					5/16	L-20-5	L-20-5U
					3/8	L-20-6	L-20-6U
					1/2	L-20-8	L-20-8U
					5/8	L-20-10	L-20-10U
					3/4	L-20-12	L-20-12U
1/4	.2501 .2504	7/16	.4392 .4389	.453 .448	1/4	L-28-4	L-28-4U
					5/16	L-28-5	L-28-5U
					3/8	L-28-6	L-28-6U
					1/2	L-28-8	L-28-8U
					5/8	L-28-10	L-28-10U
					3/4	L-28-12	L-28-12U
5/16	.3126 .3129	1/2	.5017 .5014	.520 .515	1/4	L-32-4	L-32-4U
					5/16	L-32-5	L-32-5U
					3/8	L-32-6	L-32-6U
					1/2	L-32-8	L-32-8U
					3/4	L-32-12	L-32-12U
					1	L-32-16	L-32-16U
1-3/8	L-32-22	L-32-22U					
5/16	.3126 .3129	9/16	.5642 .5639	.582 .577	1/4	L-36-4	L-36-4U
					5/16	L-36-5	L-36-5U
					3/8	L-36-6	L-36-6U
					1/2	L-36-8	L-36-8U
					5/8	L-36-10	L-36-10U
					3/4	L-36-12	L-36-12U
1	L-36-16	L-36-16U					
3/8	.3751 .3754	5/8	.6267 .6264	.645 .640	1/4	L-40-4	L-40-4U
					5/16	L-40-5	L-40-5U
					3/8	L-40-6	L-40-6U
					1/2	L-40-8	L-40-8U
					5/8	L-40-10	L-40-10U
					3/4	L-40-12	L-40-12U
1	L-40-16	L-40-16U					
7/16	.4377 .4380	5/8	.6267 .6264	.645 .640	1/4	L-40-4	L-40-4U
					5/16	L-40-5	L-40-5U
					3/8	L-40-6	L-40-6U
					1/2	L-40-8	L-40-8U
					5/8	L-40-10	L-40-10U
					3/4	L-40-12	L-40-12U
1	L-40-16	L-40-16U					
1/2	.5002 .5005	3/4	.7518 .7515	.770 .765	5/16	L-48-5	L-48-5U
					3/8	L-48-6	L-48-6U
					1/2	L-48-8	L-48-8U
					3/4	L-48-12	L-48-12U
					1	L-48-16	L-48-16U
					1-3/8	L-48-22	L-48-22U
					1-3/4	L-48-28	L-48-28U
					2-1/8	L-48-34	L-48-34U

ANSI and Acme Standard Bushings Headless Liners



Type L



All liner bushings are honed or ground in the I.D. Liners with I.D.'s 3/16" to 1" are concentric within .0003" T.I.R. to the O.D. Other I.D. sizes are held within .0005" T.I.R. All unground bushings are left rough on the O.D. with concentricity of approximately .006" T.I.R.

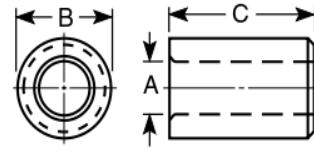

A I.D. SIZE		B BODY O.D.			C LENGTH (Overall)	ANSI SYMBOL TYPE L	
Nominal	Actual	Nominal	Actual			Ground	Unground
			Ground	Unground			
9/16	.5627 .5630	7/8	.8768 .8765	.895 .890	5/16	L-56-5	L-56-5U
					3/8	L-56-6	L-56-6U
					1/2	L-56-8	L-56-8U
					5/8	L-56-10	L-56-10U
					3/4	L-56-12	L-56-12U
					1	L-56-16	L-56-16U
5/8	.6252 .6255	7/8	.8768 .8765	.895 .890	5/16	L-56-5	L-56-5U
					3/8	L-56-6	L-56-6U
					1/2	L-56-8	L-56-8U
					5/8	L-56-10	L-56-10U
					3/4	L-56-12	L-56-12U
					1 1-1/4	L-56-16 L-56-20	L-56-16U L-56-20U
3/4	.7503 .7506	1	1.0018 1.0015	1.020 1.015	5/16	L-64-5	L-64-5U
					3/8	L-64-6	L-64-6U
					1/2	L-64-8	L-64-8U
					3/4	L-64-12	L-64-12U
					1	L-64-16	L-64-16U
					1-3/8	L-64-22	L-64-22U
					1-3/4	L-64-28	L-64-28U
					2-1/8	L-64-34	L-64-34U
					2-1/2	L-64-40	L-64-40U
					3	L-64-48	L-64-48U
7/8	.8754 .8757	1-1/4	1.2520 1.2517	1.270 1.265	3/8	L-80-6	L-80-6U
					1/2	L-80-8	L-80-8U
					5/8	L-80-10	L-80-10U
					3/4	L-80-12	L-80-12U
					1	L-80-16	L-80-16U
					1-1/4 1-1/2	L-80-20 L-80-24	L-80-20U L-80-24U
1	1.0004 1.0007	1-3/8	1.3772 1.3768	1.395 1.390	1/2	L-88-8	L-88-8U
					3/4	L-88-12	L-88-12U
					1	L-88-16	L-88-16U
					1-3/8	L-88-22	L-88-22U
					1-1/2	L-88-24	L-88-24U
					1-3/4	L-88-28	L-88-28U
					2-1/8	L-88-34	L-88-34U
					2-1/2	L-88-40	L-88-40U
					3	L-88-48	L-88-48U
1-1/4	1.2505 1.2509	1-5/8	1.6272 1.6268	1.645 1.640	5/8	L-104-10	L-104-10U
					3/4	L-104-12	L-104-12U
					1	L-104-16	L-104-16U
					1-1/4	L-104-20	L-104-20U
					1-1/2	L-104-24	L-104-24U
					1-3/4	L-104-28	L-104-28U
					2	L-104-32	L-104-32U



ANSI and Acme Standard Bushings Headless Liners

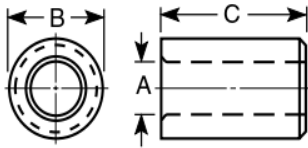

All liner bushings are honed or ground in the I.D. Liners with I.D.'s 3/16" to 1" are concentric within .0003" T.I.R. to the O.D. Other I.D. sizes are held within .0005" T.I.R. All unground bushings are left rough on the O.D. with concentricity of approximately .006" T.I.R.

Type L



A I.D. SIZE		B BODY O.D.			C LENGTH (Overall)	ANSI SYMBOL TYPE L	
Nominal	Actual	Nominal	Actual			Ground	Unground
			Ground	Unground			
1-3/8	1.3756 1.3760	1-3/4	1.7523 1.7519	1.770 1.765	3/4	L-112-12	L-112-12U
					1	L-112-16	L-112-16U
					1-3/8	L-112-22	L-112-22U
					1-1/2	L-112-24	L-112-24U
					1-3/4	L-112-28	L-112-28U
					2-1/8	L-112-34	L-112-34U
					2-1/2	L-112-40	L-112-40U
3	L-112-48	L-112-48U					
1-1/2	1.5006 1.5010	1-7/8	1.8773 1.8769	1.895 1.890	3/4	L-120-12	L-120-12U
					1	L-120-16	L-120-16U
					1-1/4	L-120-20	L-120-20U
					1-1/2	L-120-24	L-120-24U
					1-3/4	L-120-28	L-120-28U
					2	L-120-32	L-120-32U
2-1/4	L-120-36	L-120-36U					
1-3/4	1.7508 1.7512	2-1/4	2.2525 2.2521	2.270 2.265	3/4	L-144-12	L-144-12U
					1	L-144-16	L-144-16U
					1-3/8	L-144-22	L-144-22U
					1-3/4	L-144-28	L-144-28U
					2-1/8	L-144-34	L-144-34U
					2-1/2	L-144-40	L-144-40U
3	L-144-48	L-144-48U					
2-1/4	2.2510 2.2515	2-3/4	2.7526 2.7522	2.770 2.765	3/4	L-176-12	L-176-12U
					1	L-176-16	L-176-16U
					1-3/8	L-176-22	L-176-22U
					1-3/4	L-176-28	L-176-28U
					2-1/8	L-176-34	L-176-34U
					2-1/2	L-176-40	L-176-40U
3	L-176-48	L-176-48U					

ANSI and Acme Standard Bushings Head Liners



Type HL



All liner bushings are honed or ground in the I.D. Liners with I.D.'s 3/16" to 1" are concentric within .0003" T.I.R. to the O.D. Other I.D. sizes are held within .0005" T.I.R. All unground bushings are left rough on the O.D. with concentricity of approximately .006" T.I.R.

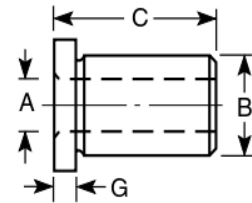

A I.D. SIZE		B BODY O.D.			C LENGTH (Overall)	ANSI SYMBOL TYPE HL		F & G HEAD SIZE
Nominal	Actual	Nominal	Actual			Ground	Unground	
			Ground	Unground				
5/16	.3126 .3129	1/2	.5017 .5014	.520 .515	5/16	HL-32-5	HL-32-5U	F 5/8 G 3/32
					3/8	HL-32-6	HL-32-6U	
					1/2	HL-32-8	HL-32-8U	
					3/4	HL-32-12	HL-32-12U	
					1	HL-32-16	HL-32-16U	
1/2	.5002 .5005	3/4	.7518 .7515	.770 .765	1-3/8	HL-32-22	HL-32-22U	
					5/16	HL-48-5	HL-48-5U	F 7/8 G 3/32
					3/8	HL-48-6	HL-48-6U	
					1/2	HL-48-8	HL-48-8U	
					3/4	HL-48-12	HL-48-12U	
1	HL-48-16	HL-48-16U						
3/4	.7503 .7506	1	1.0018 1.0015	1.020 1.015	1-3/8	HL-48-22	HL-48-22U	
					1-3/4	HL-48-28	HL-48-28U	F 1-1/8 G 1/8
					2-1/8	HL-48-34	HL-48-34U	
					2-1/2	HL-48-40	HL-48-40U	
					3	HL-48-48	HL-48-48U	
1/2	HL-64-8	HL-64-8U						
1	1.0004 1.0007	1-3/8	1.3772 1.3768	1.395 1.390	3/4	HL-64-12	HL-64-12U	
					1	HL-64-16	HL-64-16U	F 1-1/2 G 1/8
					1-3/8	HL-64-22	HL-64-22U	
					1-3/4	HL-64-28	HL-64-28U	
					2-1/8	HL-64-34	HL-64-34U	
2-1/2	HL-64-40	HL-64-40U						
1-3/8	1.3756 1.3760	1-3/4	1.7523 1.7519	1.770 1.765	3	HL-64-48	HL-64-48U	
					3/4	HL-88-8	HL-88-8U	F 1-7/8 G 3/16
					1	HL-88-12	HL-88-12U	
					1-3/8	HL-88-16	HL-88-16U	
					1-3/4	HL-88-22	HL-88-22U	
2-1/8	HL-88-28	HL-88-28U						
1-3/4	1.7508 1.7512	2-1/4	2.2525 2.2521	2.270 2.265	2-1/2	HL-88-34	HL-88-34U	
					3	HL-88-40	HL-88-40U	F 2-3/8 G 3/16
					3/4	HL-88-48	HL-88-48U	
					1	HL-112-12	HL-112-12U	
					1-3/8	HL-112-16	HL-112-16U	
1-3/4	HL-112-22	HL-112-22U						
2-1/4	2.2510 2.2515	2-3/4	2.7526 2.7522	2.770 2.765	2-1/2	HL-112-28	HL-112-28U	
					3	HL-112-34	HL-112-34U	F 2-7/8 G 3/16
					3/4	HL-112-40	HL-112-40U	
					1	HL-112-48	HL-112-48U	
					1-3/8	HL-144-12	HL-144-12U	
1-3/4	HL-144-16	HL-144-16U						
2-1/4	2.2510 2.2515	2-3/4	2.7526 2.7522	2.770 2.765	2-1/2	HL-144-22	HL-144-22U	
					3	HL-144-28	HL-144-28U	F 2-7/8 G 3/16
					3/4	HL-144-34	HL-144-34U	
					1	HL-144-40	HL-144-40U	
					1-3/8	HL-144-48	HL-144-48U	
1-3/4	HL-176-12	HL-176-12U						
2-1/4	2.2510 2.2515	2-3/4	2.7526 2.7522	2.770 2.765	2-1/2	HL-176-16	HL-176-16U	
					3	HL-176-22	HL-176-22U	F 2-7/8 G 3/16
					3/4	HL-176-28	HL-176-28U	
					1	HL-176-34	HL-176-34U	
					1-3/8	HL-176-40	HL-176-40U	
1-3/4	HL-176-48	HL-176-48U						





Extended Range Bushings Headless Press Fit

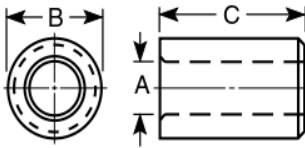

Extended Range Bushings with a ground O.D. are concentric within .0005" T.I.R. Unground Extended Range Bushings have a concentricity of .006" T.I.R. To order an unground O.D., add the letter "U" to the end of the ANSI designation.

Extended Range Bushings are not returnable.

Type P



A I.D. RANGE	1.5000 to 2.0000	1.5000 to 2.1250	1.5000 to 2.3750	1.7500 to 2.5000	2.2500 to 2.7500	2.2500 to 2.8750	2.5000 to 3.0000	2.5000 to 3.1250	2.7500 to 3.3750	3.0000 to 3.6250	3.0000 to 3.7500	3.3750 to 3.8750	3.3750 to 4.1250	3.6250 to 4.2500		
B O.D. GROUND	2.3775 to 2.3771	2.5025 to 2.5021	2.7525 to 2.7521	3.0028 to 3.0023	3.2528 to 3.2523	3.3778 to 3.3773	3.5028 to 3.5023	3.7528 to 3.7523	4.0028 to 4.0023	4.2530 to 4.2525	4.3780 to 4.3775	4.5030 to 4.5025	4.7530 to 4.7525	5.0030 to 5.0025		
B O.D. UNGROUND	2.395 to 2.390	2.520 to 2.515	2.770 to 2.765	3.020 to 3.015	3.270 to 3.265	3.395 to 3.390	3.520 to 3.515	3.770 to 3.765	4.020 to 4.015	4.270 to 4.265	4.395 to 4.390	4.520 to 4.515	4.770 to 4.765	5.020 to 5.015		
L E N G T H C	3/4	P152-12	P160-12	P176-12	P192-12	P208-12	P216-12	P224-12	P240-12	P256-12	P272-12	P280-12	P288-12	P304-12	P320-12	
	1	P152-16	P160-16	P176-16	P192-16	P208-16	P216-16	P224-16	P240-16	P256-16	P272-16	P280-16	P288-16	P304-16	P320-16	
	1-1/4	P152-20	P160-20	P176-20	P192-20	P208-20	P216-20	P224-20	P240-20	P256-20	P272-20	P280-20	P288-20	P304-20	P320-20	
	1-1/2	P152-24	P160-24	P176-24	P192-24	P208-24	P216-24	P224-24	P240-24	P256-24	P272-24	P280-24	P288-24	P304-24	P320-24	
	1-3/4	P152-28	P160-28	P176-28	P192-28	P208-28	P216-28	P224-28	P240-28	P256-28	P272-28	P280-28	P288-28	P304-28	P320-28	
	2	P152-32	P160-32	P176-32	P192-32	P208-32	P216-32	P224-32	P240-32	P256-32	P272-32	P280-32	P288-32	P304-32	P320-32	
	2-1/8	P152-34	P160-34	P176-34												
	2-1/4	P152-36	P160-36	P176-36	P192-36	P208-36	P216-36	P224-36	P240-36	P256-36	P272-36	P280-36	P288-36	P304-36	P320-36	
	2-1/2	P152-40	P160-40	P176-40	P192-40	P208-40	P216-40	P224-40	P240-40	P256-40	P272-40	P280-40	P288-40	P304-40	P320-40	
	2-3/4	P152-44	P160-44	P176-44	P192-44	P208-44	P216-44	P224-44	P240-44	P256-44	P272-44	P280-44	P288-44	P304-44	P320-44	
	3	P152-48	P160-48	P176-48	P192-48	P208-48	P216-48	P224-48	P240-48	P256-48	P272-48	P280-48	P288-48	P304-48	P320-48	
	3-1/4	P152-52	P160-52	P176-52	P192-52	P208-52	P216-52	P224-52	P240-52	P256-52	P272-52	P280-52	P288-52	P304-52	P320-52	
	3-1/2	P152-56	P160-56	P176-56	P192-56	P208-56	P216-56	P224-56	P240-56	P256-56	P272-56	P280-56	P288-56	P304-56	P320-56	
	3-3/4	P152-60	P160-60	P176-60	P192-60	P208-60	P216-60	P224-60	P240-60	P256-60	P272-60	P280-60	P288-60	P304-60	P320-60	
	4	P152-64	P160-64	P176-64	P192-64	P208-64	P216-64	P224-64	P240-64	P256-64	P272-64	P280-64	P288-64	P304-64	P320-64	
	4-1/4	P152-68	P160-68	P176-68	P192-68	P208-68	P216-68	P224-68	P240-68	P256-68	P272-68	P280-68	P288-68	P304-68	P320-68	
	4-1/2	P152-72	P160-72	P176-72	P192-72	P208-72	P216-72	P224-72	P240-72	P256-72	P272-72	P280-72	P288-72	P304-72	P320-72	
	4-3/4	P152-76	P160-76	P176-76	P192-76	P208-76	P216-76	P224-76	P240-76	P256-76	P272-76	P280-76	P288-76	P304-76	P320-76	
	5	P152-80	P160-80	P176-80	P192-80	P208-80	P216-80	P224-80	P240-80	P256-80	P272-80	P280-80	P288-80	P304-80	P320-80	
	5-1/2							P216-88	P224-88	P240-88	P256-88	P272-88	P280-88	P288-88	P304-88	P320-88
	6									P240-96	P256-96	P272-96	P280-96	P288-96	P304-96	P320-96



Extended Range Bushings

Head Press Fit



Type H



Extended Range Bushings with a ground O.D. are concentric within .0005" T.I.R. Unground Extended Range Bushings have a concentricity of .006" T.I.R. To order an unground O.D., add the letter "U" to the end of the ANSI designation.

Extended Range Bushings are not returnable.

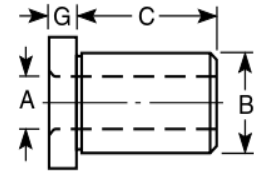

A I.D. RANGE	+0.003 to +0.007	1.5000	1.5000	1.5000	1.7500	2.2500	2.2500	2.5000	2.5000	2.7500	3.0000	3.0000	3.3750	3.3750	3.6250
		to 2.0000	to 2.1250	to 2.3750	to 2.5000	to 2.7500	to 2.8750	to 3.0000	to 3.1250	to 3.3750	to 3.6250	to 3.7500	to 3.8750	to 4.1250	to 4.2500
B O.D. GROUND		2.3775 2.3771	2.5025 2.5021	2.7525 2.7521	3.0028 3.0023	3.2528 3.2523	3.3778 3.3773	3.5028 3.5023	3.7528 3.7523	4.0028 4.0023	4.2530 4.2525	4.3780 4.3775	4.5030 4.5025	4.7530 4.7525	5.0030 5.0025
B O.D. UNGROUND		2.395 2.390	2.520 2.515	2.770 2.765	3.020 3.015	3.270 3.265	3.395 3.390	3.520 3.515	3.770 3.765	4.020 4.015	4.270 4.265	4.395 4.390	4.520 4.515	4.770 4.765	5.020 5.015
L E N G T H C	3/4	H152-12	H160-12	H176-12	H192-12	H208-12	H216-12	H224-12	H240-12	H256-12	H272-12	H280-12	H288-12	H304-12	H320-12
	1	H152-16	H160-16	H176-16	H192-16	H208-16	H216-16	H224-16	H240-16	H256-16	H272-16	H280-16	H288-16	H304-16	H320-16
	1-1/4	H152-20	H160-20	H176-20	H192-20	H208-20	H216-20	H224-20	H240-20	H256-20	H272-20	H280-20	H288-20	H304-20	H320-20
	1-1/2	H152-24	H160-24	H176-24	H192-24	H208-24	H216-24	H224-24	H240-24	H256-24	H272-24	H280-24	H288-24	H304-24	H320-24
	1-3/4	H152-28	H160-28	H176-28	H192-28	H208-28	H216-28	H224-28	H240-28	H256-28	H272-28	H280-28	H288-28	H304-28	H320-28
	2	H152-32	H160-32	H176-32	H192-32	H208-32	H216-32	H224-32	H240-32	H256-32	H272-32	H280-32	H288-32	H304-32	H320-32
	2-1/8	H152-34	H160-34	H176-34											
	2-1/4	H152-36	H160-36	H176-36	H192-36	H208-36	H216-36	H224-36	H240-36	H256-36	H272-36	H280-36	H288-36	H304-36	H320-36
	2-1/2	H152-40	H160-40	H176-40	H192-40	H208-40	H216-40	H224-40	H240-40	H256-40	H272-40	H280-40	H288-40	H304-40	H320-40
	2-3/4	H152-44	H160-44	H176-44	H192-44	H208-44	H216-44	H224-44	H240-44	H256-44	H272-44	H280-44	H288-44	H304-44	H320-44
	3	H152-48	H160-48	H176-48	H192-48	H208-48	H216-48	H224-48	H240-48	H256-48	H272-48	H280-48	H288-48	H304-48	H320-48
	3-1/4	H152-52	H160-52	H176-52	H192-52	H208-52	H216-52	H224-52	H240-52	H256-52	H272-52	H280-52	H288-52	H304-52	H320-52
	3-1/2	H152-56	H160-56	H176-56	H192-56	H208-56	H216-56	H224-56	H240-56	H256-56	H272-56	H280-56	H288-56	H304-56	H320-56
	3-3/4	H152-60	H160-60	H176-60	H192-60	H208-60	H216-60	H224-60	H240-60	H256-60	H272-60	H280-60	H288-60	H304-60	H320-60
	4	H152-64	H160-64	H176-64	H192-64	H208-64	H216-64	H224-64	H240-64	H256-64	H272-64	H280-64	H288-64	H304-64	H320-64
	4-1/4	H152-68	H160-68	H176-68	H192-68	H208-68	H216-68	H224-68	H240-68	H256-68	H272-68	H280-68	H288-68	H304-68	H320-68
	4-1/2	H152-72	H160-72	H176-72	H192-72	H208-72	H216-72	H224-72	H240-72	H256-72	H272-72	H280-72	H288-72	H304-72	H320-72
	4-3/4	H152-76	H160-76	H176-76	H192-76	H208-76	H216-76	H224-76	H240-76	H256-76	H272-76	H280-76	H288-76	H304-76	H320-76
	5	H152-80	H160-80	H176-80	H192-80	H208-80	H216-80	H224-80	H240-80	H256-80	H272-80	H280-80	H288-80	H304-80	H320-80
	5-1/2						H216-88	H224-88	H240-88	H256-88	H272-88	H280-88	H288-88	H304-88	H320-88
6								H240-96	H256-96	H272-96	H280-96	H288-96	H304-96	H320-96	
HEAD SIZE	F	2-3/4	2-3/4	3	3-1/4	3-1/2	3-5/8	3-7/8	4-1/8	4-3/8	4-5/8	4-3/4	4-7/8	5-1/8	5-3/8
	G	3/8	3/8	3/8	3/8	3/8	3/8	1/2	1/2	1/2	1/2	1/2	1/2	1/2	1/2





Extended Range Bushings

Slip-Fixed Renewable

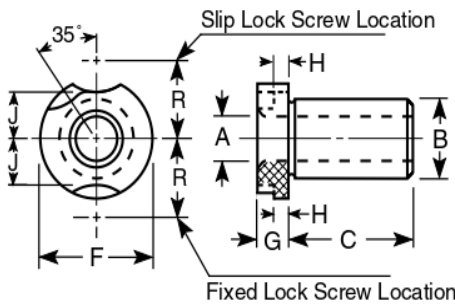

Extended Range Slip-Fixed Renewable Bushings are ground to slip fit into Liners and are concentric within .0005" T.I.R.
 Extended Range Bushings are not returnable.

Type SF



A I.D. RANGE	+0.0003 to +0.0007	1.0937 to 1.5312	1.5000 to 2.0312	1.5000 to 2.2812	1.7500 to 2.5312	2.2500 to 2.6250	2.2500 to 2.8750	2.6250 to 2.8750	2.5000 to 3.1250	2.7500 to 3.2500	3.0000 to 3.5000	3.0000 to 3.6250	3.3750 to 3.7500	3.3750 to 4.0000	3.6250 to 4.2500
B O.D.		2.0000 to 1.9996	2.5000 to 2.4996	2.7500 to 2.7496	3.0000 to 2.9996	3.2500 to 3.2496	3.3750 to 3.3746	3.5000 to 3.4996	3.7500 to 3.7496	4.0000 to 3.9996	4.2500 to 4.2496	4.3750 to 4.3746	4.5000 to 4.4996	4.7500 to 4.7496	5.0000 to 4.9996
LENGTH	3/4	SF128-12	SF160-12	SF176-12	SF192-12	SF208-12	SF216-12	SF224-12	SF240-12	SF256-12	SF272-12	SF280-12	SF288-12	SF304-12	SF320-12
	1	SF128-16	SF160-16	SF176-16	SF192-16	SF208-16	SF216-16	SF224-16	SF240-16	SF256-16	SF272-16	SF280-16	SF288-16	SF304-16	SF320-16
	1-1/4	SF128-20	SF160-20	SF176-20	SF192-20	SF208-20	SF216-20	SF224-20	SF240-20	SF256-20	SF272-20	SF280-20	SF288-20	SF304-20	SF320-20
	1-1/2	SF128-24	SF160-24	SF176-24	SF192-24	SF208-24	SF216-24	SF224-24	SF240-24	SF256-24	SF272-24	SF280-24	SF288-24	SF304-24	SF320-24
	1-3/4	SF128-28	SF160-28	SF176-28	SF192-28	SF208-28	SF216-28	SF224-28	SF240-28	SF256-28	SF272-28	SF280-28	SF288-28	SF304-28	SF320-28
	2	SF128-32	SF160-32	SF176-32	SF192-32	SF208-32	SF216-32	SF224-32	SF240-32	SF256-32	SF272-32	SF280-32	SF288-32	SF304-32	SF320-32
	2-1/8	SF128-34	SF160-34	SF176-34											
	2-1/4	SF128-36	SF160-36	SF176-36	SF192-36	SF208-36	SF216-36	SF224-36	SF240-36	SF256-36	SF272-36	SF280-36	SF288-36	SF304-36	SF320-36
	2-1/2	SF128-40	SF160-40	SF176-40	SF192-40	SF208-40	SF216-40	SF224-40	SF240-40	SF256-40	SF272-40	SF280-40	SF288-40	SF304-40	SF320-40
	2-3/4	SF128-44	SF160-44	SF176-44	SF192-44	SF208-44	SF216-44	SF224-44	SF240-44	SF256-44	SF272-44	SF280-44	SF288-44	SF304-44	SF320-44
	3	SF128-48	SF160-48	SF176-48	SF192-48	SF208-48	SF216-48	SF224-48	SF240-48	SF256-48	SF272-48	SF280-48	SF288-48	SF304-48	SF320-48
	3-1/4	SF128-52	SF160-52	SF176-52	SF192-52	SF208-52	SF216-52	SF224-52	SF240-52	SF256-52	SF272-52	SF280-52	SF288-52	SF304-52	SF320-52
	3-1/2	SF128-56	SF160-56	SF176-56	SF192-56	SF208-56	SF216-56	SF224-56	SF240-56	SF256-56	SF272-56	SF280-56	SF288-56	SF304-56	SF320-56
	3-3/4	SF128-60	SF160-60	SF176-60	SF192-60	SF208-60	SF216-60	SF224-60	SF240-60	SF256-60	SF272-60	SF280-60	SF288-60	SF304-60	SF320-60
	4	SF128-64	SF160-64	SF176-64	SF192-64	SF208-64	SF216-64	SF224-64	SF240-64	SF256-64	SF272-64	SF280-64	SF288-64	SF304-64	SF320-64
	4-1/4	SF128-68	SF160-68	SF176-68	SF192-68	SF208-68	SF216-68	SF224-68	SF240-68	SF256-68	SF272-68	SF280-68	SF288-68	SF304-68	SF320-68
	4-1/2	SF128-72	SF160-72	SF176-72	SF192-72	SF208-72	SF216-72	SF224-72	SF240-72	SF256-72	SF272-72	SF280-72	SF288-72	SF304-72	SF320-72
	4-3/4	SF128-76	SF160-76	SF176-76	SF192-76	SF208-76	SF216-76	SF224-76	SF240-76	SF256-76	SF272-76	SF280-76	SF288-76	SF304-76	SF320-76
	5	SF128-80	SF160-80	SF176-80	SF192-80	SF208-80	SF216-80	SF224-80	SF240-80	SF256-80	SF272-80	SF280-80	SF288-80	SF304-80	SF320-80
	5-1/2						SF216-88	SF224-88	SF240-88	SF256-88	SF272-88	SF280-88	SF288-88	SF304-88	SF320-88
HEAD SIZE	F	2-9/16	3-1/16	3-7/16	3-11/16	3-15/16	4-1/16	4-3/16	4-9/16	4-13/16	5-1/16	5-3/16	5-5/16	5-9/16	5-13/16
	G	3/8	3/8	7/16	7/16	7/16	7/16	7/16	7/16	1/2	1/2	1/2	1/2	1/2	1/2
	H	3/16	3/16	7/32	7/32	7/32	7/32	7/32	7/32	1/4	1/4	1/4	1/4	1/4	1/4
	J	1-1/8	1-3/8	1-35/64	1-43/64	1-51/64	1-55/64	1-59/64	2-7/64	2-15/64	2-23/64	2-27/64	2-31/64	2-39/64	2-47/64
	R	1-33/64	1-49/64	1-15/16	2-1/16	2-3/16	2-1/4	2-5/16	2-1/2	2-5/8	2-3/4	2-13/16	2-7/8	3	3-1/8
Lock Screw		3A-LS	3A-LS	4A-LS	4A-LS	4A-LS	4A-LS	4A-LS	4A-LS	5A-LS	5A-LS	5A-LS	5A-LS	5A-LS	5A-LS

Extended Range Bushings Headless Liners



Type L



Extended Range Bushings with a ground O.D. are concentric within .0005" T.I.R. Unground Extended Range Bushings have a concentricity of .006" T.I.R. To order an unground O.D., add the letter "U" to the end of the ANSI designation.

Extended Range Bushings are not returnable.

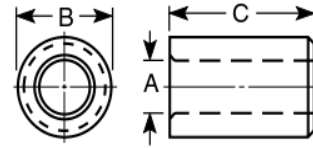

A I.D. SIZE	2.0010 2.0015	2.5010 2.5015	2.7510 2.7515	3.0010 3.0015	3.2510 3.2515	3.3760 3.3765	3.5010 3.5015	3.7510 3.7515	4.0010 4.0015	4.2510 4.2515	4.3760 4.3765	4.5010 4.5015	4.7510 4.7515	5.0010 5.0015	
B O.D. GROUND	2.5025 2.5021	3.0028 3.0023	3.3778 3.3773	3.6278 3.6273	3.8778 3.8773	4.0028 4.0023	4.1280 4.1275	4.5030 4.5025	4.7530 4.7525	5.0030 5.0025	5.1280 5.1275	5.2530 5.2525	5.5030 5.5025	5.7530 5.7525	
B O.D. UNGROUND	2.520 2.515	3.020 3.015	3.395 3.390	3.645 3.640	3.895 3.890	4.020 4.015	4.145 4.140	4.520 4.515	4.770 4.765	5.020 5.015	5.145 5.140	5.270 5.265	5.520 5.515	5.770 5.765	
L E N G T H C	3/4	L160-12	L192-12	L216-12	L232-12	L248-12	L256-12	L264-12	L288-12	L304-12	L320-12	L328-12	L336-12	L352-12	L368-12
	1	L160-16	L192-16	L216-16	L232-16	L248-16	L256-16	L264-16	L288-16	L304-16	L320-16	L328-16	L336-16	L352-16	L368-16
	1-1/4	L160-20	L192-20	L216-20	L232-20	L248-20	L256-20	L264-20	L288-20	L304-20	L320-20	L328-20	L336-20	L352-20	L368-20
	1-1/2	L160-24	L192-24	L216-24	L232-24	L248-24	L256-24	L264-24	L288-24	L304-24	L320-24	L328-24	L336-24	L352-24	L368-24
	1-3/4	L160-28	L192-28	L216-28	L232-28	L248-28	L256-28	L264-28	L288-28	L304-28	L320-28	L328-28	L336-28	L352-28	L368-28
	2	L160-32	L192-32	L216-32	L232-32	L248-32	L256-32	L264-32	L288-32	L304-32	L320-32	L328-32	L336-32	L352-32	L368-32
	2-1/8	L160-34	L192-34	L216-34											
	2-1/4	L160-36	L192-36	L216-36	L232-36	L248-36	L256-36	L264-36	L288-36	L304-36	L320-36	L328-36	L336-36	L352-36	L368-36
	2-1/2	L160-40	L192-40	L216-40	L232-40	L248-40	L256-40	L264-40	L288-40	L304-40	L320-40	L328-40	L336-40	L352-40	L368-40
	2-3/4	L160-44	L192-44	L216-44	L232-44	L248-44	L256-44	L264-44	L288-44	L304-44	L320-44	L328-44	L336-44	L352-44	L368-44
	3	L160-48	L192-48	L216-48	L232-48	L248-48	L256-48	L264-48	L288-48	L304-48	L320-48	L328-48	L336-48	L352-48	L368-48
	3-1/4	L160-52	L192-52	L216-52	L232-52	L248-52	L256-52	L264-52	L288-52	L304-52	L320-52	L328-52	L336-52	L352-52	L368-52
	3-1/2	L160-56	L192-56	L216-56	L232-56	L248-56	L256-56	L264-56	L288-56	L304-56	L320-56	L328-56	L336-56	L352-56	L368-56
	3-3/4	L160-60	L192-60	L216-60	L232-60	L248-60	L256-60	L264-60	L288-60	L304-60	L320-60	L328-60	L336-60	L352-60	L368-60
	4	L160-64	L192-64	L216-64	L232-64	L248-64	L256-64	L264-64	L288-64	L304-64	L320-64	L328-64	L336-64	L352-64	L368-64
	4-1/4	L160-68	L192-68	L216-68	L232-68	L248-68	L256-68	L264-68	L288-68	L304-68	L320-68	L328-68	L336-68	L352-68	L368-68
	4-1/2	L160-72	L192-72	L216-72	L232-72	L248-72	L256-72	L264-72	L288-72	L304-72	L320-72	L328-72	L336-72	L352-72	L368-72
	4-3/4	L160-76	L192-76	L216-76	L232-76	L248-76	L256-76	L264-76	L288-76	L304-76	L320-76	L328-76	L336-76	L352-76	L368-76
	5	L160-80	L192-80	L216-80	L232-80	L248-80	L256-80	L264-80	L288-80	L304-80	L320-80	L328-80	L336-80	L352-80	L368-80
	5-1/2						L256-88	L264-88	L288-88	L304-88	L320-88	L328-88	L336-88	L352-88	L368-88



Get quote »



Extended Range Bushings Head Liners

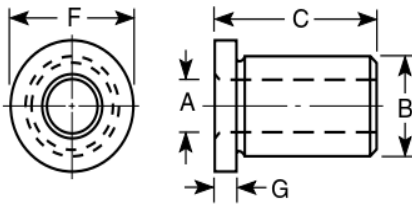

Extended Range Bushings with a ground O.D. are concentric within .0005" T.I.R. Unground Extended Range Bushings have a concentricity of .006" T.I.R. To order an unground O.D., add the letter "U" to the end of the ANSI designation.

Extended Range Bushings are not returnable.

Type HL



A I.D. SIZE	2.0010 2.0015	2.5010 2.5015	2.7510 2.7515	3.0010 3.0015	3.2510 3.2515	3.3760 3.3765	3.5010 3.5015	3.7510 3.7515	4.0010 4.0015	4.2510 4.2515	4.3760 4.3765	4.5010 4.5015	4.7510 4.7515	5.0010 5.0015	
B O.D. GROUND	2.5025 2.5021	3.0028 3.0023	3.3778 3.3773	3.6278 3.6273	3.8778 3.8773	4.0028 4.0023	4.1280 4.1275	4.5030 4.5025	4.7530 4.7525	5.0030 5.0025	5.1280 5.1275	5.2530 5.2525	5.5030 5.5025	5.7530 5.7525	
B O.D. UNGROUND	2.520 2.515	3.020 3.015	3.395 3.390	3.645 3.640	3.895 3.890	4.020 4.015	4.145 4.140	4.520 4.515	4.770 4.765	5.020 5.015	5.145 5.140	5.270 5.265	5.520 5.515	5.770 5.765	
L E N G T H C	3/4	HL160-12	HL192-12	HL216-12	HL232-12	HL248-12	HL256-12	HL264-12	HL288-12	HL304-12	HL320-12	HL328-12	HL336-12	HL352-12	HL368-12
	1	HL160-16	HL192-16	HL216-16	HL232-16	HL248-16	HL256-16	HL264-16	HL288-16	HL304-16	HL320-16	HL328-16	HL336-16	HL352-16	HL368-16
	1-1/4	HL160-20	HL192-20	HL216-20	HL232-20	HL248-20	HL256-20	HL264-20	HL288-20	HL304-20	HL320-20	HL328-20	HL336-20	HL352-20	HL368-20
	1-1/2	HL160-24	HL192-24	HL216-24	HL232-24	HL248-24	HL256-24	HL264-24	HL288-24	HL304-24	HL320-24	HL328-24	HL336-24	HL352-24	HL368-24
	1-3/4	HL160-28	HL192-28	HL216-28	HL232-28	HL248-28	HL256-28	HL264-28	HL288-28	HL304-28	HL320-28	HL328-28	HL336-28	HL352-28	HL368-28
	2	HL160-32	HL192-32	HL216-32	HL232-32	HL248-32	HL256-32	HL264-32	HL288-32	HL304-32	HL320-32	HL328-32	HL336-32	HL352-32	HL368-32
	2-1/8	HL160-34	HL192-34	HL216-34											
	2-1/4	HL160-36	HL192-36	HL216-36	HL232-36	HL248-36	HL256-36	HL264-36	HL288-36	HL304-36	HL320-36	HL328-36	HL336-36	HL352-36	HL368-36
	2-1/2	HL160-40	HL192-40	HL216-40	HL232-40	HL248-40	HL256-40	HL264-40	HL288-40	HL304-40	HL320-40	HL328-40	HL336-40	HL352-40	HL368-40
	2-3/4	HL160-44	HL192-44	HL216-44	HL232-44	HL248-44	HL256-44	HL264-44	HL288-44	HL304-44	HL320-44	HL328-44	HL336-44	HL352-44	HL368-44
	3	HL160-48	HL192-48	HL216-48	HL232-48	HL248-48	HL256-48	HL264-48	HL288-48	HL304-48	HL320-48	HL328-48	HL336-48	HL352-48	HL368-48
	3-1/4	HL160-52	HL192-52	HL216-52	HL232-52	HL248-52	HL256-52	HL264-52	HL288-52	HL304-52	HL320-52	HL328-52	HL336-52	HL352-52	HL368-52
	3-1/2	HL160-56	HL192-56	HL216-56	HL232-56	HL248-56	HL256-56	HL264-56	HL288-56	HL304-56	HL320-56	HL328-56	HL336-56	HL352-56	HL368-56
	3-3/4	HL160-60	HL192-60	HL216-60	HL232-60	HL248-60	HL256-60	HL264-60	HL288-60	HL304-60	HL320-60	HL328-60	HL336-60	HL352-60	HL368-60
	4	HL160-64	HL192-64	HL216-64	HL232-64	HL248-64	HL256-64	HL264-64	HL288-64	HL304-64	HL320-64	HL328-64	HL336-64	HL352-64	HL368-64
	4-1/4	HL160-68	HL192-68	HL216-68	HL232-68	HL248-68	HL256-68	HL264-68	HL288-68	HL304-68	HL320-68	HL328-68	HL336-68	HL352-68	HL368-68
	4-1/2	HL160-72	HL192-72	HL216-72	HL232-72	HL248-72	HL256-72	HL264-72	HL288-72	HL304-72	HL320-72	HL328-72	HL336-72	HL352-72	HL368-72
	4-3/4	HL160-76	HL192-76	HL216-76	HL232-76	HL248-76	HL256-76	HL264-76	HL288-76	HL304-76	HL320-76	HL328-76	HL336-76	HL352-76	HL368-76
	5	HL160-80	HL192-80	HL216-80	HL232-80	HL248-80	HL256-80	HL264-80	HL288-80	HL304-80	HL320-80	HL328-80	HL336-80	HL352-80	HL368-80
	5-1/2							HL256-88	HL264-88	HL288-88	HL304-88	HL320-88	HL328-88	HL336-88	HL352-88
HEAD SIZE	F	2-5/8	3-1/8	3-1/2	3-7/8	4-1/8	4-1/4	4-3/8	4-3/4	5	5-1/4	5-3/8	5-1/2	5-3/4	6
	G	3/16	3/16	3/16	3/16	3/16	3/16	3/16	7/32	7/32	7/32	7/32	7/32	7/32	7/32

Extra-Thinwall Bushings

Type XTW



All "XTW" bushings are lapped, honed or ground in the I.D. Bushings with I.D.'s of 1/8" to 1" are ground to give a uniform wall thickness within .0003" T.I.R. Other I.D. sizes are held within .0005" T.I.R. Wall thickness (W) must fall within the range indicated in the chart below to be considered "XTW".

Because of the extremely thin wall, this type bushing tends to assume the shape of the hole into which it is inserted or the shape of the arbor onto which it is pressed. It will not necessarily be round in the free state.

Unless specified otherwise, "Xtra-Thinwall" Bushings will be manufactured to the following tolerances:

- I.D. - Standard I.D. tolerances
- O.D. - Type XTWP and XTWH: Standard press fit tolerances
- Type XTWSF: Standard slip-fit tolerances

Xtra-Thinwall Bushings are not returnable.
Prices on request.

Type XTWP

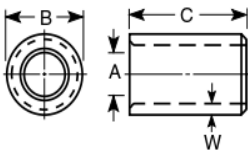

Type XTWH

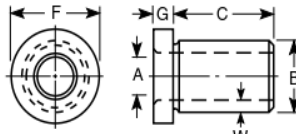

Type XTWSF

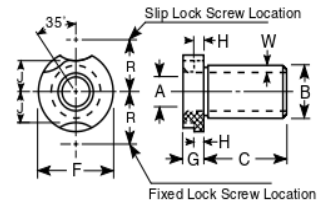

A I.D. Range	B O.D. Range	W Wall Thickness	C Length (Specify)	HEAD DIMENSIONS TYPE XTWH		HEAD DIMENSIONS TYPE XTWSF					
				F	G	F	G	H	J	R	Lock Screw
.0135 to .0485	.0785 to .1285	.0325 to .0400		1/4	3/32	5/16	3/16	3/32	3/32	17/64	#1-LS
.0486 to .0625	.0786 to .1425	.015 to .040		1/4	3/32	5/16	3/16	3/32	3/32	17/64	#1-LS
.0626 to .0995	.0926 to .1795	.015 to .040		5/16	3/32	5/16	3/16	3/32	3/32	17/64	#1-LS
.0996 to .1405	.1376 to .2305	.018 to .045		23/64	3/32	7/16	1/4	1/8	9/64	23/64	#2-LS
.1406 to .1910	.1786 to .2850	.019 to .047		27/64	1/8	35/64	1/4	1/8	11/64	1/2	1A-LS
.1911 to .2280	.2311 to .3140	.020 to .048		27/64	1/8	5/8	1/4	1/8	15/64	29/64	#2-LS
.2281 to .2900	.2671 to .3900	.021 to .050		1/2	5/32	5/8	1/4	1/8	15/64	29/64	#2-LS
.2901 to .3437	.3341 to .4577	.022 to .052		39/64	7/32	51/64	1/4	1/8	19/64	5/8	1A-LS
.3438 to .4375	.3918 to .5475	.024 to .055		11/16	3/32	7/8	1/4	1/8	23/64	37/64	#2-LS
.4376 to .5311	.4916 to .6512	.027 to .060		59/64	7/32	1-3/64	1/4	1/8	27/64	3/4	1A-LS
.5312 to .6561	.5913 to .7862	.030 to .065		1-7/64	1/4	1-1/4	3/8	3/16	31/64	53/64	2A-LS
.6562 to .7500	.7223 to .8900	.033 to .070		1-15/64	5/16	1-27/64	3/8	3/16	19/32	59/64	2A-LS
.7501 to .8437	.8201 to .9877	.035 to .072		1-15/64	5/16	1-27/64	3/8	3/16	19/32	59/64	2A-LS
.8438 to .9375	.9148 to 1.0875	.037 to .075		1-1/2	1/4	1-5/8	3/8	3/16	43/64	1-1/64	2A-LS
.9376 to 1.0000	1.0176 to 1.1600	.040 to .080		1-1/2	1/4	1-5/8	3/8	3/16	43/64	1-1/64	2A-LS





Embedment Bushings For Use In Soft Materials

Type DG

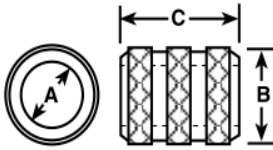

The Diamond-Groove type (DG) has a special knurl that provides superior holding strength in potting compounds and castable materials. The number of grooves is dependent on the length of the bushing.

Type SG

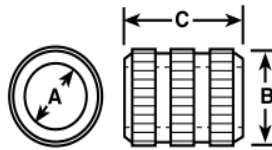

The Ser-Groove (SG) bushing consists of a serration that permits the bushing to be pressed into a jig or fixture made of soft material or laminated fiberglass while maintaining its holding strength.

Type SL

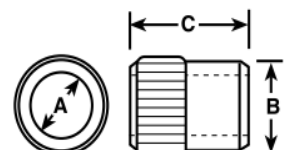

The Spline-Lock (SL) type bushing features a partially serrated and partially ground outside diameter. This configuration enables the bushing to be pressed into soft metals or wood.

A I.D. RANGE (Std. Drill Sizes)		B BODY O.D.			C LENGTH (Overall)	ORDERING SYMBOL		
Decimal	Numbers, Letters, and Fractions†	Nominal	Actual			Diamond - Groove (Type DG)	Ser - Groove (Type SG)	Spline - Lock (Type SL)
			DG & SG	SL				
.0980 to .1406	#40 to #28 7/64 to 9/64	1/4	.275 .260	.2500 .2498	1/4 5/16 3/8 1/2	DG-16-4 DG-16-5 DG-16-6 DG-16-8	SG-16-4 SG-16-5 SG-16-6 SG-16-8	SL-16-4 SL-16-5 SL-16-6 SL-16-8
.1406 to .1935	#27 to #10 9/64 to 3/16	5/16	.337 .322	.3125 .3123	1/4 5/16 3/8 1/2 3/4	DG-20-4 DG-20-5 DG-20-6 DG-20-8 DG-20-12	SG-20-4 SG-20-5 SG-20-6 SG-20-8 SG-20-12	SL-20-5 SL-20-6 SL-20-8 SL-20-12
.1875 to .2570	#12 to #1 "A" to "F" 3/16 to 1/4	13/32	.431 .416	.4062 .4060	1/4 5/16 3/8 1/2 3/4	DG-26-4 DG-26-5 DG-26-6 DG-26-8 DG-26-12	SG-26-4 SG-26-5 SG-26-6 SG-26-8 SG-26-12	SL-26-5 SL-26-6 SL-26-8 SL-26-12
.2500 to .3160	"F" to "O" 1/4 to 5/16	1/2	.525 .510	.5000 .4998	5/16 3/8 1/2 3/4	DG-32-5 DG-32-6 DG-32-8 DG-32-12	SG-32-5 SG-32-6 SG-32-8 SG-32-12	SL-32-5 SL-32-6 SL-32-8 SL-32-12
.3125 to .4375	"O" to "Z" 5/16 to 7/16	5/8	.650 .635	.6250 .6248	3/8 1/2 3/4 1 1-3/8	DG-40-6 DG-40-8 DG-40-12 DG-40-16 DG-40-22	SG-40-6 SG-40-8 SG-40-12 SG-40-16 SG-40-22	SL-40-6 SL-40-8 SL-40-12 SL-40-16
.4375 to .5312	7/16 to 17/32	3/4	.775 .760	.7500 .7498	3/8 1/2 3/4 1 1-3/8	DG-48-6 DG-48-8 DG-48-12 DG-48-16 DG-48-22	SG-48-6 SG-48-8 SG-48-12 SG-48-16 SG-48-22	SL-48-6 SL-48-8 SL-48-12 SL-48-16
.5000 to .6562	1/2 to 21/32	7/8	.900 .885	.8750 .8748	3/8 1/2 3/4 1 1-3/8	DG-56-6 DG-56-8 DG-56-12 DG-56-16 DG-56-22	SG-56-6 SG-56-8 SG-56-12 SG-56-16 SG-56-22	SL-56-6 SL-56-8 SL-56-12 SL-56-16
.6250 to .7656	5/8 to 49/64	1"	1.025 1.010	1.0000 .9998	1/2 3/4 1 1-3/8	DG-64-8 DG-64-12 DG-64-16 DG-64-22	SG-64-8 SG-64-12 SG-64-16 SG-64-22	SL-64-8 SL-64-12 SL-64-16 SL-64-22

† Fraction I.D. Range is in increments of 1/64" (except where indicated otherwise)
Embedment Bushings are Priced on Request

I.D. Range (Drill Size)	Standard I.D. Tolerance (add to nominal I.D.)
7/64 to 1/4	+ .0001 to + .0004
Over 1/4 to 3/4	+ .0001 to + .0005
Over 3/4 to 49/64	+ .0002 to + .0006

Tungsten Carbide Bushings Headless and Head Press Fit



Type CP

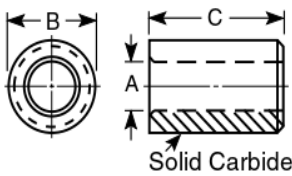

Solid Carbide

Type CH

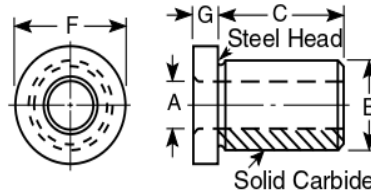

Solid Carbide

A I.D. RANGE (Std. Drill Sizes)		B BODY O.D.		C LENGTH (Under Head)	ANSI SYMBOL		HEAD SIZES (Type CH Only)	
Decimal	Numbers, Letters, and Fractions†	Nominal	Actual Ground		Headless Press Fit (Type CP)	Head Press Fit (Type CH)	F	G
.0135 to .0312	#80 to #68 1/64 and 1/32	5/32	.1578 .1575	1/4 5/16	CP-10-4 CP-10-5			
.0320 to .0469	#67 to #56 3/64	5/32	.1578 .1575	1/4 5/16 1/2	CP-10-4 CP-10-5 CP-10-8			
.0520 to .0995	#55 to #39 1/16 to 3/32	13/64	.2046 .2043	1/4 5/16 1/2	CP-13-4 CP-13-5 CP-13-8	CH-13-5 CH-13-8	19/64	3/32
.1015 to .1360	#38 to #29 7/64 and 1/8	1/4	.2516 .2513	1/4 5/16 1/2	CP-16-4 CP-16-5 CP-16-8	CH-16-5 CH-16-8	23/64	3/32
.1405 to .1875	#28 to #13 9/64 to 3/16	5/16	.3141 .3138	5/16 1/2 3/4 1	CP-20-5 CP-20-8 CP-20-12 CP-20-16	CH-20-5 CH-20-8 CH-20-12 CH-20-16	27/64	1/8
.1890 to .2500	#12 to #1 "A" to "D" 13/64 to 1/4	13/32	.4078 .4075	5/16 1/2 3/4 1	CP-26-5 CP-26-8 CP-26-12 CP-26-16	CH-26-5 CH-26-8 CH-26-12 CH-26-16	1/2	5/32
.2570 to .3125	"F" to "N" 17/64 to 5/16	1/2	.5017 .5014	5/16 1/2 3/4 1 1-3/8	CP-32-5 CP-32-8 CP-32-12 CP-32-16 CP-32-22	CH-32-5 CH-32-8 CH-32-12 CH-32-16 CH-32-22	39/64	7/32
.3160 to .4219	"O" to "Z" 21/64 to 27/64	5/8	.6267 .6264	1/2 3/4 1 1-3/8	CP-40-8 CP-40-12 CP-40-16 CP-40-22	CH-40-8 CH-40-12 CH-40-16 CH-40-22	51/64	7/32
.4375 to .5000	7/16 to 1/2	3/4	.7518 .7515	1/2 3/4 1 1-3/8	CP-48-8 CP-48-12 CP-48-16 CP-48-22	CH-48-8 CH-48-12 CH-48-16 CH-48-22	59/64	7/32
.5156 to .6250	33/64 to 5/8	7/8	.8768 .8765	3/4 1 1-3/8 1-3/4	CP-56-12 CP-56-16 CP-56-22 CP-56-28	CH-56-12 CH-56-16 CH-56-22 CH-56-28	1-7/64	1/4
.6406 to .7500	41/64 to 3/4	1	1.0018 1.0015	1/2 3/4 1 1-3/8 1-3/4	CP-64-8 CP-64-12 CP-64-16 CP-64-22 CP-64-28	CH-64-8 CH-64-12 CH-64-16 CH-64-22 CH-64-28	1-15/64	5/16
.7656 to 1.0000	49/64 to 1"	1-3/8	1.3772 1.3768	3/4 1 1-3/8 1-3/4 2-1/8 2-1/2	CP-88-12 CP-88-16 CP-88-22 CP-88-28 CP-88-34 CP-88-40	CH-88-12 CH-88-16 CH-88-22 CH-88-28 CH-88-34 CH-88-40	1-39/64	3/8
1.0156 to 1.3750	1-1/64 to 1-3/8	1-3/4	1.7523 1.7519	1 1-3/8 1-3/4 2-1/8 2-1/2 3	CP-112-16 CP-112-22 CP-112-28 CP-112-34 CP-112-40 CP-112-48	CH-112-16 CH-112-22 CH-112-28 CH-112-34 CH-112-40 CH-112-48	1-63/64	3/8
1.3906 to 1.7500	1-25/64 to 1-3/4	2-1/4	2.2525 2.2521	1 1-3/8 1-3/4 2-1/8 2-1/2 3	CP-144-16 CP-144-22 CP-144-28 CP-144-34 CP-144-40 CP-144-48	CH-144-16 CH-144-22 CH-144-28 CH-144-34 CH-144-40 CH-144-48	2-31/64	3/8

† Fraction I.D. Range is in increments of 1/64" (except where indicated otherwise)

Prices on Request

Carbide Bushings are not Returnable



Get quote »



Tungsten Carbide Bushings Slip-Fixed Renewable

Type CSF

I.D. Range (Drill Size)	Standard I.D. Tolerance (add to nominal I.D.)
#80 to 1/4	+0.0001 to +0.0004
Over 1/4 to 3/4	+0.0001 to +0.0005
Over 3/4 to 1-1/2	+0.0002 to +0.0006
Over 1-1/2 to 1-3/4	+0.0003 to +0.0007

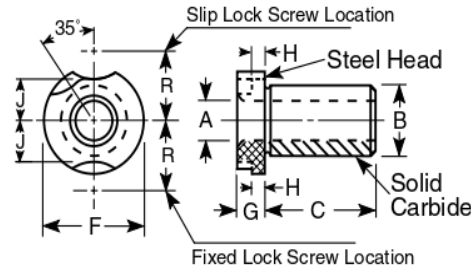

A I.D. RANGE (Std. Drill Sizes)		B Body O.D		C Length (Under Head)	ANSI SYMBOL Slip-Fixed Renewable (Type CSF)	HEAD SIZE					Lock Screws and Clamps
Decimal	Numbers, Letters, and Fractions†	Nominal	Actual			F	G	H	J	R	
.0520 to .1562	#55 to #23 1/16 to 5/32	5/16	.3125 .3123	5/16 1/2 3/4 1	CSF-20-5 CSF-20-8 CSF-20-12 CSF-20-16	35/64	1/4	1/8	11/64	1/2	1A-LS RC-1A
.1570 to .3125	#22 to #1 "A" to "N" 11/64 to 5/16	1/2	.5000 .4998	5/16 1/2 3/4 1 1-3/8	CSF-32-5 CSF-32-8 CSF-32-12 CSF-32-16 CSF-32-22	51/64	1/4	1/8	19/64	5/8	1A-LS RC-1A
.3160 to .5000	"O" to "Z" 21/64 to 1/2	3/4	.7500 .7498	1/2 3/4 1 1-3/8	CSF-48-8 CSF-48-12 CSF-48-16 CSF-48-22	1-3/64	1/4	1/8	27/64	3/4	1A-LS RC-1A
.5156 to .7500	33/64 to 3/4	1	1.0000 .9998	1/2 3/4 1 1-3/8 1-3/4	CSF-64-8 CSF-64-12 CSF-64-16 CSF-64-22 CSF-64-28	1-27/64	3/8	3/16	19/32	59/64	2A-LS RC-2A
.7656 to 1.0000	49/64 to 1"	1-3/8	1.3750 1.3747	3/4 1 1-3/8 1-3/4 2-1/8 2-1/2	CSF-88-12 CSF-88-16 CSF-88-22 CSF-88-28 CSF-88-34 CSF-88-40	1-51/64	3/8	3/16	25/32	1-7/64	2A-LS RC-2A
1.0156 to 1.3750	1-1/64 to 1-3/8	1-3/4	1.7500 1.7497	1 1-3/8 1-3/4 2-1/8 2-1/2 3	CSF-112-16 CSF-112-22 CSF-112-28 CSF-112-34 CSF-112-40 CSF-112-48	2-19/64	3/8	3/16	1	1-25/64	3A-LS RC-3A
1.3906 to 1.7500	1-25/64 to 1-3/4	2-1/4	2.2500 2.2496	1 1-3/8 1-3/4 2-1/8 2-1/2 3	CSF-144-16 CSF-144-22 CSF-144-28 CSF-144-34 CSF-144-40 CSF-144-48	2-51/64	3/8	3/16	1-1/4	1-41/64	3A-LS RC-3A

† Fraction I.D. Range is in increments of 1/64" (except where indicated otherwise)

Prices on Request

Carbide Bushings are not Returnable

Carbide Bushings are also available in Metric sizes.

ACME ULTIMATE™ BUSHINGS

- Is the brittle nature of Carbide Bushings unacceptable for your application?
 - Does the quantity of bushings you require for a job make Carbide Bushings cost prohibitive?
 - Is the abrasive action of Carbide Bushings causing premature tool wear?
- Acme Ultimate Bushings are the answer!

Acme Ultimate bushings are Titanium Nitride (TiN) coated for longer life. Titanium Nitride coated bushings have a hardness of 82-85 RC. This increase in surface hardness means the bushings can stand the abrasive wear of tools and chips for much longer periods of time and are less brittle than carbide bushings.

The TiN coating on Acme Ultimate Bushings has a very slippery surface. This slippery surface on the I.D. of the bushing will help increase tool life.

The greater the number of bushings needed for an application, the more Acme Ultimate Bushings can reduce your cost.

Contact us for more information.

GUN DRILL BUSHINGS



Type GDB

Acme Type GDB Bushings are thru-hardened to 61–65 RC and ground concentric within .0002" T.I.R. The head is undercut and ground square to the outside diameter. The face is square to the inside diameter within .0002" T.I.R. Type GDB Bushings are manufactured from semi-finished inventory for quick delivery.

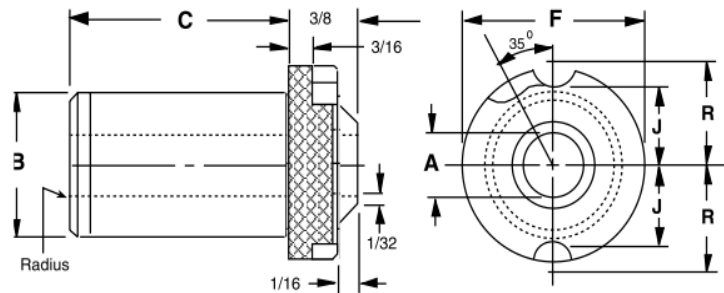

Description	A I.D. Range +.0002 / -.0000	B O.D. Size		C Length (Under Head)	Head Dimensions			Lockscrew
		Nominal	Actual		F	J	R	
GDB-64-16	3/16 – 25/32 (.1875) (.7812)	1"	1.0000 .9998	1"	1-27/64	19/32	59/64	2A-LS
GDB-64-22	1/4 – 25/32 (.2500) (.7812)			1-3/8				
GDB-88-16	3/16 – 1-1/16 (.1875) (1.0625)	1-3/8	1.3750 1.3748	1"	1-51/64	25/32	1-7/64	2A-LS
GDB-88-22	1/4 – 1-1/16 (.2500) (1.0625)			1-3/8				

Type GDX

Type GDX Bushings are made to the same high standards as Acme's other Gun Drill Bushings. The I.D. is ground concentric to the O.D. within .0002" T.I.R. and the face is also square to the I.D. within .0002" T.I.R. The head is undercut and ground square to the O.D. The O.D. of length "D" is left unground. GDX Bushings are made from tool steel and thru-hardened to 61–65 RC. Special sizes and materials are available on request.

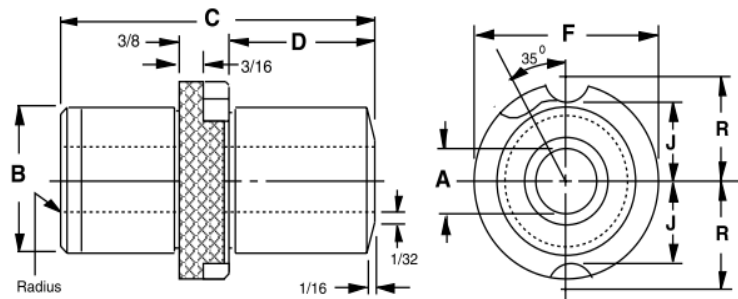

Description	A I.D. Range +.0002 / -.0000	B O.D. Size		C Overall Length	D	Head Dimensions			Lockscrew
		Nominal	Actual			F	J	R	
GDX-88-30	3/16 – 1-1/16 (.1875) (1.0625)	1-3/8	1.3750 1.3748	1-7/8	1/2	1-51/64	25/32	1-7/64	2A-LS
GDX-88-38	1/4 – 1-1/16 (.2500) (1.0625)			2-3/8	1"				
GDX-88-46	9/32 – 1-1/16 (.2812) (1.0625)			2-7/8	1-1/2				
GDX-88-54	5/16 – 1-1/16 (.3125) (1.0625)			3-3/8	2"				



GUN DRILL BUSHINGS

Liners – Type GDL

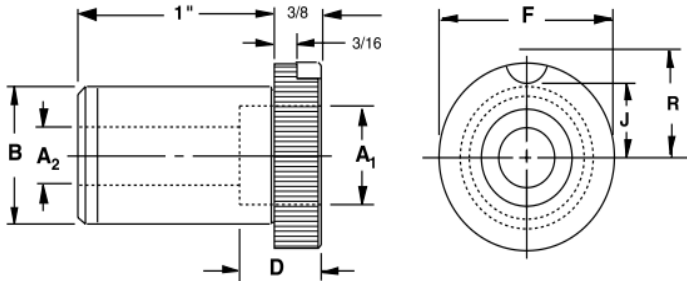

Acme Gun Drill Liners are designed to be used with the replaceable inserts indicated in the table below. All type GDL Bushings are ground concentric within .0002" T.I.R. The heads are undercut and ground square with outside diameters so the liner will seat flat against the chip box.

Part Number	Description	A ₁ +.0002 -.0000	A ₂ ±.005	B O.D. Size		D	Head Dimensions			Lockscrew	Insert Used
				Nominal	Actual		F	J	R		
A51210	GDL-64-16	.2045	.125	1"	1.0000 .9998	7/16	1-27/64	19/32	59/64	2A-LS	GDI-13-8
A51212		.2515	.156								GDI-16-8
A51214		.3140	.218								GDI-20-8
A51216		.5016	.406								GDI-32-8
A51218		.7517	.625								GDI-48-8
A51240	GDL-88-16	.2045	.125	1-3/8	1.3750 1.3748	7/16	1-51/64	25/32	1-7/64	2A-LS	GDI-13-8
A51242		.2515	.156								GDI-16-8
A51244		.3140	.218								GDI-20-8
A51246		.5016	.406								GDI-32-8
A51248		.7517	.625								GDI-48-8
A51250		1.0017	.875			11/16	1-51/64	25/32	1-7/64	2A-LS	GDI-64-12

Inserts – Type GDI

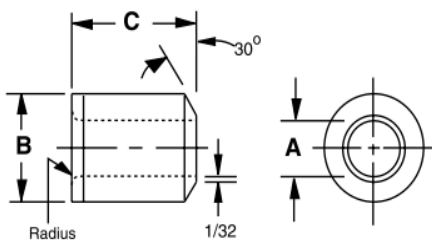

Acme Gun Drill Inserts are manufactured from thru-hardened tool steel and heat treated to 61–65 RC for longer life. The I.D., O.D., and face of GDI Bushings are ground concentric and square within .0002" T.I.R.

Inserts are stocked in standard drill sizes only. Special I.D. sizes and special materials (ie. Carbide or Titanium Nitride coating) are available to meet your requirements.

Description	A I.D. Range +.0002 / -.0000	B O.D. Size		C Length
		Nominal	Actual	
GDI-13-8	5/64 – #39 (.0781) (.0995)	13/64	.2047 .2044	1/2
GDI-16-8	#38 – 9/64 (.1015) (.1406)	1/4	.2517 .2514	1/2
GDI-20-8	#27 – #10 (.1440) (.1935)	5/16	.3142 .3139	1/2
GDI-32-8	9 – 0 (.1960) (.3160)	1/2	.5018 .5015	1/2
GDI-48-8	P – 17/32 (.3230) (.5312)	3/4	.7519 .7516	1/2
GDI-64-12	35/64 – 3/4 (.5469) (.7500)	1"	1.0019 1.0016	3/4

Oil Groove Bushings Type OG



Wiper Styles:

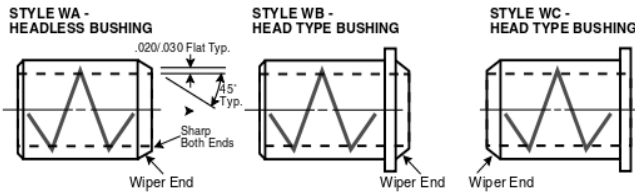

Wiper Specifications: Oil groove does not run out on wiper end.

Material: Tool Steel unless specified otherwise by customer.

Range: 1/2" to 8" I.D. and 1/2" to 6" long. Styles 1-9 must be 5/8" I.D. or larger.

Oil Grooves: 1/16" wide x 1/32" deep

Oil Holes: 1/8" Diam. (If I.D., O.D., and/or Length are 1" or less, Oil hole will be 1/8" Diam. and O.D. groove will be 3/16" wide x 1/32" deep).

Order by: Acme/ANSI Symbol or by I.D., O.D. and Length, indicating desired style of Oil Groove. Example: Style 18 Oil Groove, 1" X 1-3/8" x 3/4" Type P and WA Wiper.

Prices Available on Request

Oil Groove Bushings are not Returnable

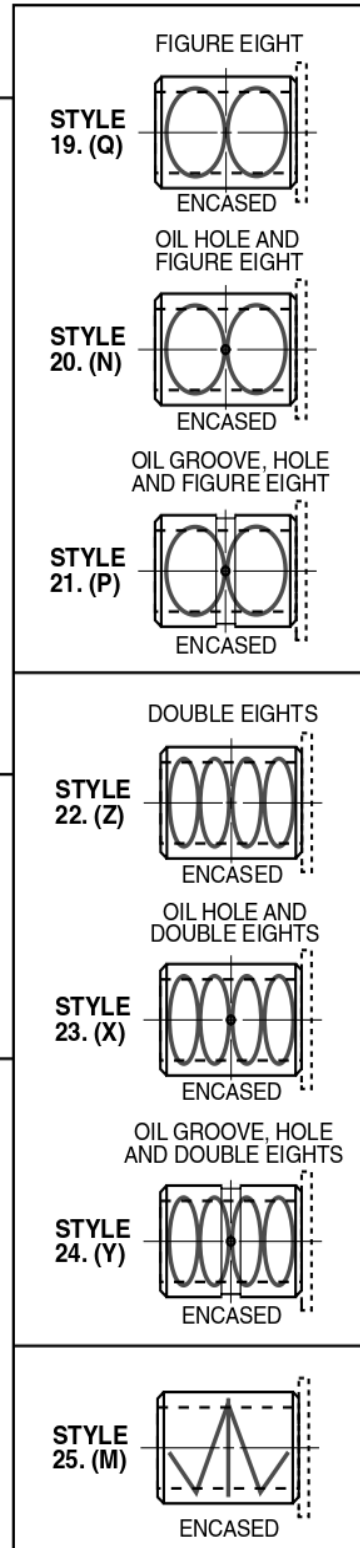
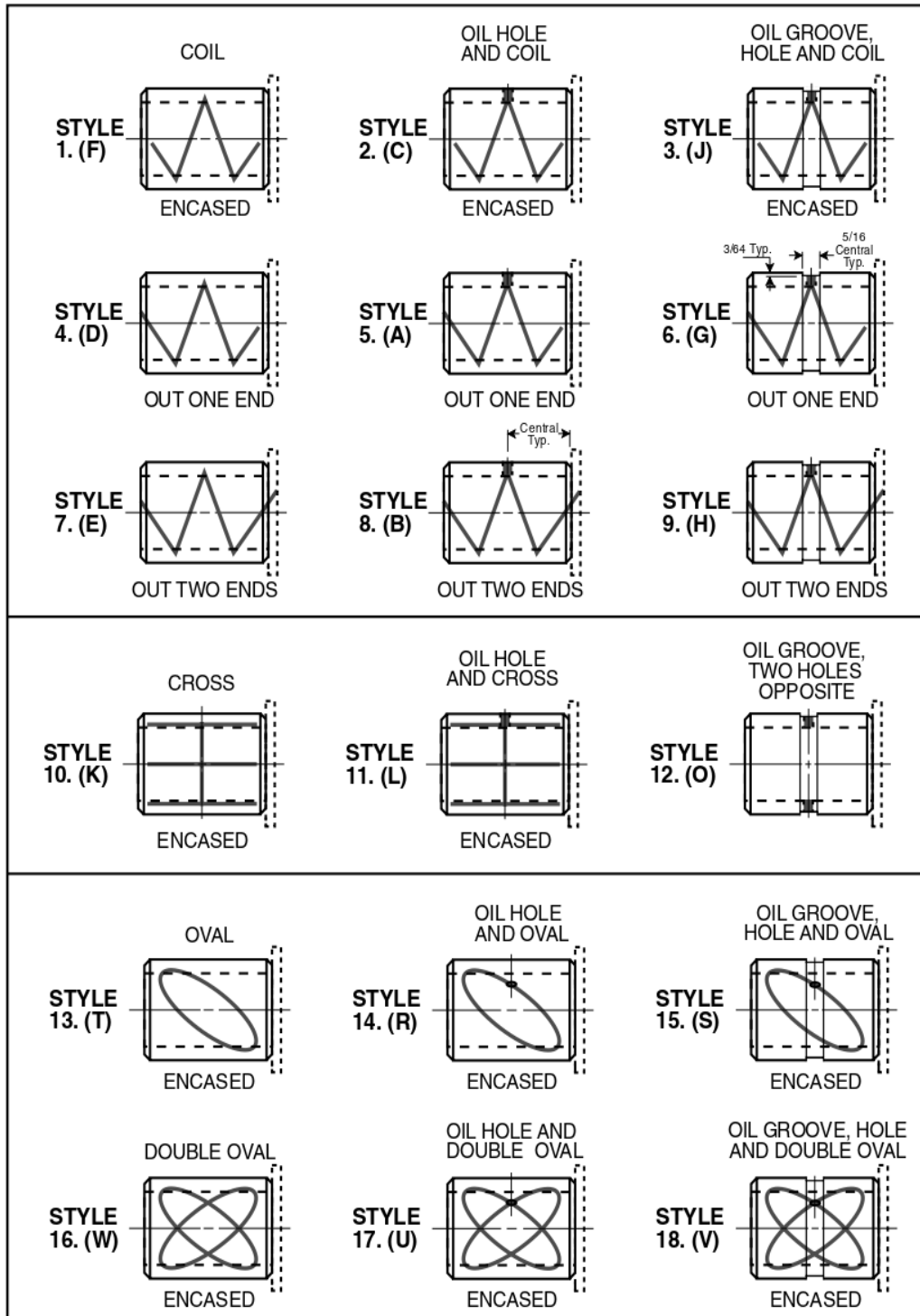



Lockscrews & Clamps

Lock Screws

Part Number	Symbol	G	H	I	J	L	Thread
A00012	#1-LS	3/16	.100 .094	3/16	5/16	1/4	8-32
A00016	#2-LS	1/4	.132 .128	1/4	3/8	1/4	10-32
A00014	1A-LS	1/4	.138 .132	3/8	5/8		5/16-18
A00018	2A-LS	3/8	.200 .194	3/8	5/8	1/2	5/16-18
A00022	3A-LS	3/8	.200 .194	7/16	3/4		3/8-16
A00026	4A-LS	7/16	.231 .225	7/16	3/4	5/8	3/8-16
A00030	5A-LS	1/2	.263 .257	7/16	3/4		3/8-16

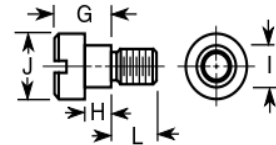

Round Clamps

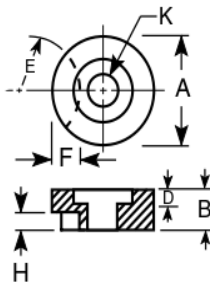

Part Number	Symbol	A	B	D	E	F	H	K
A00002	RC-1A	5/8	5/16	5/32	17/32	.109	1/8	5/16 SOC. HD. SCR.
A00004	RC-2A	5/8	7/16	7/32	29/32	.125	3/16	5/16 SOC. HD. SCR.
A00006	RC-3A	3/4	1/2	9/32	1-13/32	.156	3/16	3/8 SOC. HD. SCR.
A00008	RC-4A	3/4	17/32	1/4	2-1/2	.156	7/32	3/8 SOC. HD. SCR.
A00010	RC-5A	3/4	9/16	1/4	2-1/2	.156	1/4	3/8 SOC. HD. SCR.

Flat Clamps



FOR FLUSH MOUNTING WITH HEADLESS LINERS (TYPE L)										
Part Number	Symbol	A	B	C	D	E	F	H	K	No. of Holes
A00050	FC-1	1/2	5/16	5/16	5/8	7/8	3/16	1/8	1/4 SOC. HD. SCR.	1
A00051	FC-2	5/8	3/8	1/2	1	1	1/4	3/16	5/16 SOC. HD. SCR.	1
A00052	FC-3	5/8	3/8	1/2	1	1-1/8	5/16	3/16	5/16 SOC. HD. SCR.	1
A00053	FC-4	51/64	3/8	5/8	1-1/4	1-11/64	27/64	7/32	3/8 SOC. HD. SCR.	1
A00054	FC-5	51/64	3/8	3/8	1-3/4	1-11/64	27/64	7/32	3/8 SOC. HD. SCR.	2
A00055	FC-6	51/64	1/2	5/8	1-1/4	1-11/64	27/64	1/4	3/8 SOC. HD. SCR.	1
A00056	FC-7	51/64	1/2	3/8	1-3/4	1-11/64	27/64	1/4	3/8 SOC. HD. SCR.	2
FOR PROJECTED MOUNTING WITH HEAD LINERS (TYPE HL)										
A00058	FC-11	1/2	3/8	5/16	5/8	7/8	3/16	1/4	1/4 SOC. HD. SCR.	1
A00059	FC-12	5/8	1/2	1/2	1	1	1/4	5/16	5/16 SOC. HD. SCR.	1
A00060	FC-13	5/8	1/2	1/2	1	1	1/4	3/8	5/16 SOC. HD. SCR.	1
A00061	FC-14	5/8	1/2	5/8	1-1/4	1-1/8	5/16	3/8	3/8 SOC. HD. SCR.	1
A00062	FC-15	5/8	1/2	3/8	1-3/4	1-1/8	5/16	3/8	3/8 SOC. HD. SCR.	2
A00064	FC-21	51/64	3/4	3/8	1-3/4	1-11/64	27/64	15/32	3/8 SOC. HD. SCR.	2

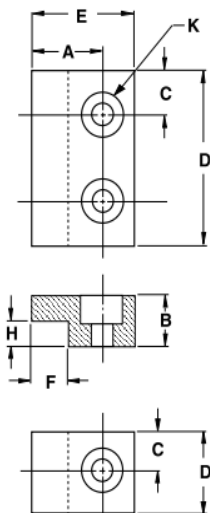

Special / Custom Drill Bushings



To Standardize is to Economize
— Always try to order a standard bushing

Where possible, ACME will modify ANSI/ACME standard bushings to meet your requirements. This will save you money. However, we will gladly manufacture to your specifications and tolerances.

Just photocopy this page, fill in the necessary information and mail or FAX to:

ACME INDUSTRIAL COMPANY
441 Maple Avenue
Carpentersville, IL 60110
Attn: Customer Service Department

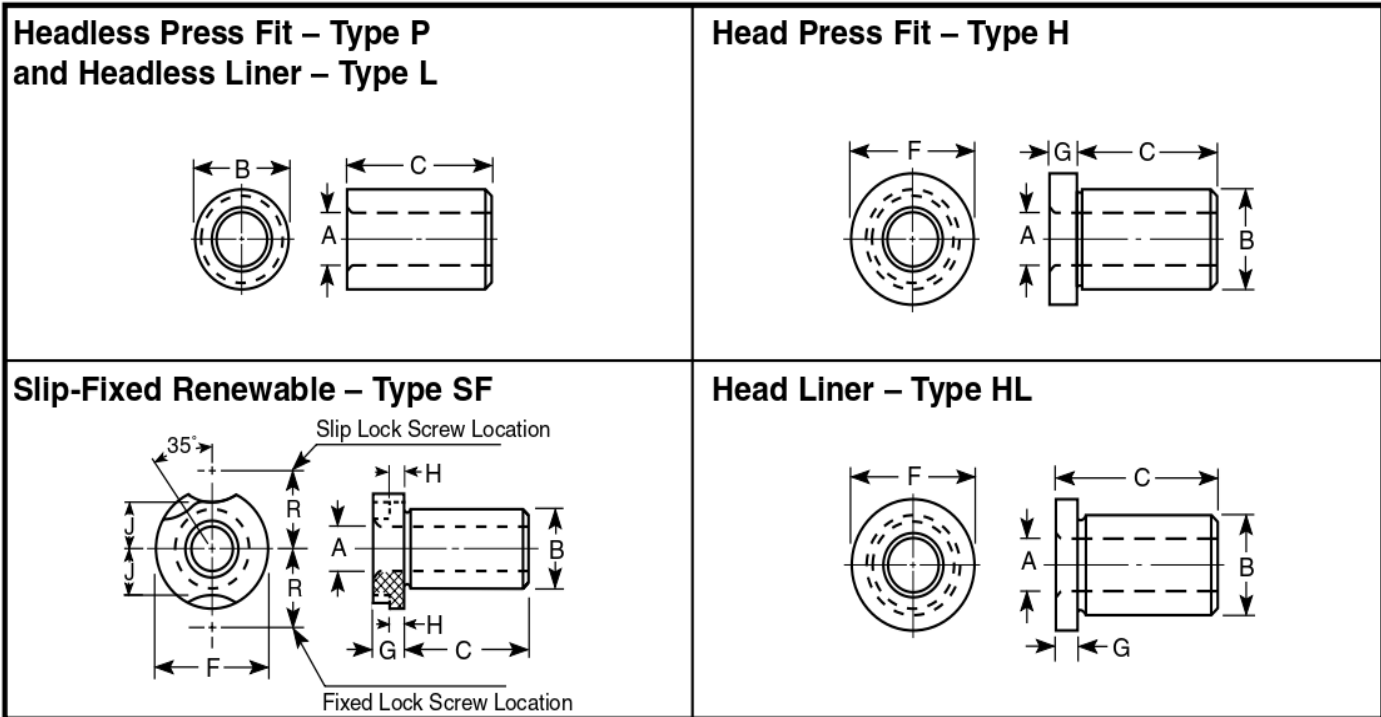

Please Fill in the Required Dimensions:

A (I.D.)	B (O.D.)	C (Length)	F (Head Diam.)	G (Head Thick.)

- Our standard tolerances will be supplied unless otherwise specified.
- Please specify to four decimal places.
- No-Counterbore is standard unless specified otherwise.

Please check the type of bushing desired:

- P = Headless Press Fit
- H = Head Press Fit
- SF = Slip-Fixed Renewable
- L = Headless Liners
- HL = Head Liners

Material Required _____
Hardness of _____ RC
Quantities Required _____
and _____

Additional Information:

If you need any further assistance in ordering special/custom drill bushings, please call our customer service department for help:

Phone: (847) 428-3911 or
(800) 323-5582
FAX: (847) 428-1820

Name: _____ Title: _____

Company: _____

Address: _____

City: _____ State: _____ Zip: _____

Telephone: _____ FAX: _____ E-mail: _____



Get quote »



TOOL HOLDER BUSHINGS

CNC Style Type Z

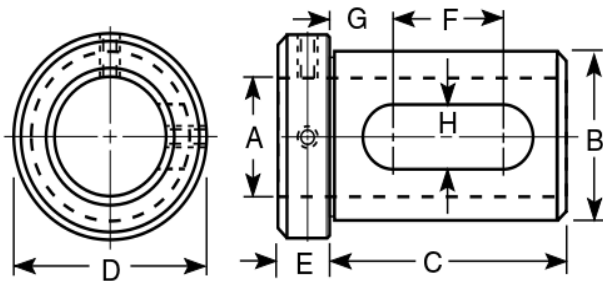

Acme Part Number	A I.D.	B O.D.	C Length (Under Head)	HEAD DIMENSIONS		F	G	H
				D O.D.	E Thickness			
A52321	1/2							
A52322	5/8							
A52323	3/4	1-1/2	3-1/4	2	3/4	2	11/16	7/8
A52325	7/8							
A52327	1							
A52328	1-1/4							
A52331	1/2							
A52332	5/8							
A52333	3/4	1-3/4	3-1/2	2-1/4	3/4	2	11/16	7/8
A52334	7/8							
A52335	1							
A52336	1-1/4							
A52337	1-1/2							
A52343	3/4							
A52344	7/8							
A52345	1	2	3-3/4	2-1/2	3/4	2-1/8	3/4	1
A52346	1-1/4							
A52347	1-1/2							
A52348	1-3/4							
A52352	3/4							
A52354	1							
A52355	1-1/4	2-1/2	4-1/4	3	3/4	2-1/8	7/8	1
A52356	1-1/2							
A52357	1-3/4							
A52358	2							
A52359	2-1/4							
A52361	1							
A52362	1-1/4							
A52363	1-1/2							
A52364	1-3/4	3	4-3/4	3-1/2	3/4	2-1/4	1	1-1/4
A52365	2							
A52366	2-1/4							
A52367	2-1/2							

Acme CNC Tool Holder Bushings are designed to adapt tools such as drills and boring bars to NC or CNC machine tools. The elongated slots on the body make adapting tools to all brands of equipment a snap. Set screws in the head of these bushings permit use with preset tooling. Type Z bushings are hardened and ground for long life and precision alignment.

TOOL HOLDER BUSHINGS



Split Style Type B

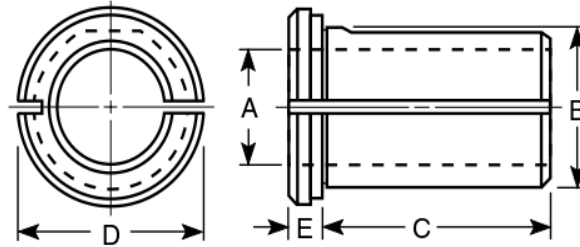

Type B Tool Holder Bushings are split through the entire length of the bushing on one side. This enables the bushing to clamp on the shank of cutting tools by tightening the screws in the turret bore or tool holder. Acme Type B bushings are hardened and precision ground to provide a longer lasting more accurate bushing. Solid, soft blanks with a machine finish are available upon request.

Acme Part Number	A I.D.	B O.D.	C Length (Under Head)	HEAD DIMENSIONS	
				D O.D.	E Thickness
A52001	5/16	3/4	1-1/2	7/8	3/16
A52002	3/8				
A52003	1/2				
A52010	3/8	1	1-3/4	1-7/32	3/16
A52011	1/2				
A52012	5/8				
A52013	3/4				
A52014	3/8	1-1/4	2-1/8	1-11/32	1/4
A52015	1/2				
A52016	5/8				
A52017	3/4				
A52018	7/8				
A52019	1				
A52020	3/8	1-1/2	2-1/2	1-23/32	1/4
A52021	1/2				
A52022	5/8				
A52023	3/4				
A52025	7/8				
A52027	1				
A52028	1-1/4				
A52031	1/2				
A52032	5/8				
A52033	3/4				
A52035	1				
A52036	1-1/4				
A52037	1-1/2				
A52041	1/2	2	3-1/2	2-7/32	5/16
A52042	5/8				
A52043	3/4				
A52045	1				
A52046	1-1/4				
A52047	1-1/2				
A52048	1-3/4				
A52050	1/2				
A52051	5/8				
A52052	3/4				
A52054	1				
A52055	1-1/4				
A52056	1-1/2				
A52057	1-3/4				
A52058	2				
A52059	2-1/4				
A52063	1-1/2	3	4-1/2	3-1/2	7/16
A52064	1-3/4				
A52065	2				
A52066	2-1/4				
A52067	2-1/2				



TOOL HOLDER BUSHINGS

Solid Style Type J

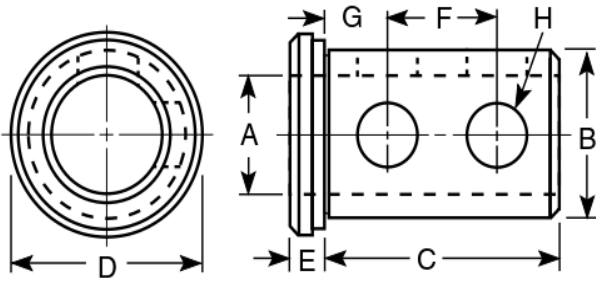

Acme Type J Tool Holder Bushings have clearance holes for set screws for proper clamping on the shank of tools. These bushings are hardened and ground for long life and accurate alignment. Solid, soft blanks for custom machining are available on request.



Acme Part Number	A I.D.	B O.D.	C Length (Under Head)	HEAD DIMENSIONS		F	G	H	Number of Holes
				D O.D.	E Thickness				
A52114	3/8	1-1/4	2-1/8	1-15/32	1/4	1	1/2	5/8	2
A52115	1/2								
A52116	5/8								
A52117	3/4								
A52118	7/8								
A52119	1								
A52121	1/2	1-1/2	2-1/2	1-23/32	1/4	1-1/8	11/16	7/8	2
A52122	5/8								
A52123	3/4								
A52125	7/8								
A52127	1								
A52128	1-1/4								
A52131	1/2	1-3/4	3	1-31/32	5/16	1-1/4	3/4	7/8	2
A52132	5/8								
A52133	3/4								
A52134	7/8								
A52135	1								
A52136	1-1/4								
A52137	1-1/2								
A52143	3/4	2	3-1/2	2-7/32	5/16	1-1/2	3/4	1	2
A52144	7/8								
A52145	1								
A52146	1-1/4								
A52147	1-1/2								
A52148	1-3/4								
A52152	3/4	2-1/2	4	2-27/32	3/8	1-3/4	7/8	1-1/4	2
A52154	1								2
A52155	1-1/4								4
A52156	1-1/2								4
A52157	1-3/4								4
A52158	2	4							
A52159	2-1/4	4							
A52161	1	3	4-1/2	3-1/2	7/16	2	1	1-1/4	2
A52162	1-1/4								4
A52163	1-1/2								4
A52164	1-3/4								4
A52165	2								4
A52166	2-1/4	4							
A52167	2-1/2	4							

TOOL HOLDER BUSHINGS



Slotted Style

Type C

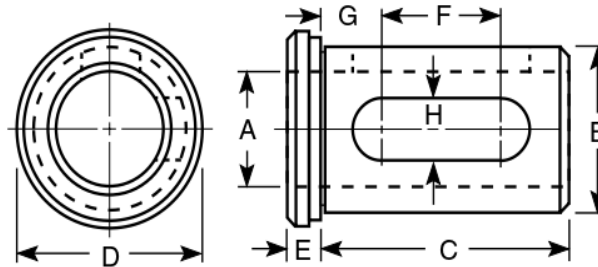

Acme Type C Tool Holder Bushings have an elongated slot to allow set screws to properly clamp on the shank of tools. Type C bushings are hardened and ground for a more accurate, longer lasting bushing.

Acme Part Number	A I.D.	B O.D.	C Length (Under Head)	HEAD DIMENSIONS			F	G	H
				D O.D.	E Thickness				
A52214	3/8								
A52215	1/2								
A52216	5/8	1-1/4	3-1/4	1-15/32	17/64	2	11/16	3/4	
A52217	3/4								
A52218	7/8								
A52219	1								
A52221	1/2								
A52222	5/8								
A52223	3/4	1-1/2	3-3/8	1-23/32	17/64	2	11/16	7/8	
A52225	7/8								
A52227	1								
A52228	1-1/4								
A52231	1/2								
A52232	5/8								
A52233	3/4	1-3/4	3-1/2	1-31/32	19/64	2-1/8	11/16	7/8	
A52234	7/8								
A52235	1								
A52236	1-1/4								
A52237	1-1/2								
A52243	3/4								
A52244	7/8								
A52245	1	2	4	2-7/32	19/64	2-1/2	11/16	1	
A52246	1-1/4								
A52247	1-1/2								
A52248	1-3/4								
A52252	3/4								
A52254	1								
A52255	1-1/4	2-1/2	4-1/2	2-27/32	21/64	2-3/4	11/16	1	
A52256	1-1/2								
A52257	1-3/4								
A52258	2								
A52259	2-1/4								
A52261	1								
A52262	1-1/4								
A52263	1-1/2								
A52264	1-3/4	3	5	3-1/2	3/8	3-1/2	3/4	1	
A52265	2								
A52266	2-1/4								
A52267	2-1/2								

Bushings with O.D.'s greater than 2" and I.D.'s 1-1/4" and larger have two slots. All others have one slot.



TOOL HOLDER BUSHINGS

Boring Bar Sleeves

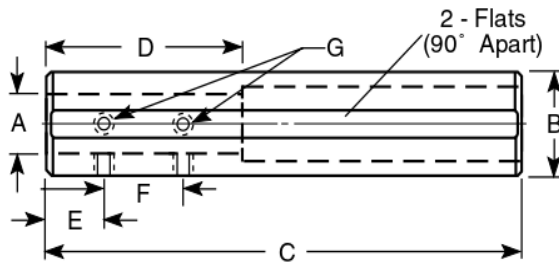

Acme Part Number	A I.D.	B O.D.	C Length	D	E	F	G SCREW SIZE
A53401	3/8	1	6	1-3/4	7/16	7/8	1/4-28
A53402	1/2		6	2	7/16	7/8	1/4-28
A53411	3/8	1-1/2	6	1-1/2	7/16	7/8	#10-32
A53412	1/2		6	2	7/16	1	5/16-24
A53413	5/8		6	2	7/16	1	5/16-24
A53414	3/4		6	2	7/16	1	5/16-24
A53415	7/8		8	2	7/16	1	7/16-20
A53421	1/2	1-3/4	8	2-1/2	7/16	1	5/16-24
A53422	3/4		8	2-1/2	7/16	1	7/16-20
A53423	1		8	2-1/2	7/16	1	7/16-20
A53431	5/8	2	9	2	7/16	1	7/16-20
A53432	3/4		9	2	1/2	1	7/16-20
A53433	7/8		9	2	1/2	1	7/16-20
A53434	1		9	3	1/2	1	1/2-20
A53435	1-1/4		9	3	1/2	1	1/2-20
A53441	5/8	2-1/2	10	2-1/4	1/2	1	1/2-20
A53442	3/4		10	2-3/4	1/2	1	1/2-20
A53443	1		10	3-1/2	1/2	1	1/2-20
A53444	1-1/4		10	3-1/2	1/2	1	1/2-20
A53445	1-1/2		10	3-1/2	1/2	1	1/2-20
A53450	1	3	11-1/2	3-1/2	1/2	1	1/2-20
A53451	1-1/4		11-1/2	3-1/2	1/2	1	1/2-20
A53452	1-1/2		11-1/2	3-3/4	1/2	1	1/2-20
A53453	1-3/4		11-1/2	3-3/4	1/2	1	1/2-20
A53454	2		11-1/2	3-3/4	1/2	1	1/2-20
A53462	2	4	14	3-3/4	5/8	1-3/4	5/8-18
A53463	2-1/2		14	4	5/8	2	5/8-18

Acme Boring Bar Sleeves are ideal for adapting boring bars and other shank type tools to machine turret bores or tool holders. The long lengths and sturdy construction provide extra support to extend the range of the tool. These sleeves are hardened and ground. Special sizes can be manufactured to your specifications.

Standard Metric Bushings

Technical Information



No-Counterbore Bushings are Standard with ACME

Acme is committed to the concept of manufacturing our bushings without a counterbore. No-Counterbore bushings are more difficult and costly to produce, because close tolerances are required the full length of the bushing. We believe this produces a better, longer lasting and more versatile bushing. Counterbored bushings will be supplied only upon special request.

Plain Press Fit Bushings -Type PM

- Least expensive
- Typically for single stage drilling operations
- Permits close spacing
- Mounts flush with top of jig plate
- Length is measured overall

Head Press Fit Bushings - Type HM

- Same as Plain Press Fit but with head (or shoulder) on the drill entry end
- Head prevents heavy axial loads from forcing bushing through jig hole
- Flush mount by counterboring jig plate to fit bushing head
- Length is measured overall

Slip-Fixed Renewable Bushings - Type SFM

- Fixed and removable options on one knurled head for easier use
- Used with liner, permanently pressed into jig
- Held in place by lock screw or clamp which fits a milled recess in the head
- Fixed mode for runs longer than life of bushing
- Slip mode for multiple operations on the same holes (such as drilling followed by reaming)
- O.D. has a slip fit tolerance for easy insertion or removal from the liner
- Length is measured under the head

Plain Liners - Type PM

- Used with Slip-Fixed Renewable bushings to provide precise location point
- Permits interchange of Type SFM bushings with varied I.D.'s – without affecting centerline accuracy
- Permanently pressed into jig plate – for life of the jig
- Protects jig plate hole from wear caused by frequent bushing replacement
- Used where little impact or force will occur on the SF bushing's head
- Plain Liners are the same as Plain Press Fit Bushings

Head Liners - Type HM

- Similar to Plain Liners but with a head or shoulder
- Use with Slip-Fixed Renewable bushings whenever excessive pounding or force will occur during operation
- Head prevents liner from being pushed through jig plate
- Flush mount by counterboring top of hole in jig plate
- Length is measured overall
- Head Liners are the same as Head Press Fit Bushings

Bushing Installation

Production accuracy requires extra care when preparing mounting holes and installing bushings/liners. The following factors should be considered: interference fits, alignment, chip clearance, and how close the bushing is to the workpiece.

Because of the many variables, no definite rules can substitute for the skill and judgment of the experienced toolmaker.

Interference Fits

Interference holds press fit bushings in the jig plate. Too much interference may cause a number of problems: (1) jig plate distortion; (2) bellmouthing (bushing/liner walls bow inward); (3) tool seizure, or (4) trouble with slip-fixed renewable fitting into the liner. Too little interference may allow slippage, thus causing inaccurately drilled holes.



Standard Metric Bushings

Technical Information

Mounting Hole Preparation

It is recommended that all mounting holes be jig bored or sized with a reamer to assure roundness. Bushings tend to assume the shape of the hole they are pressed into. See chart below for recommended size.

The recommended installation hole size should be in accordance with metric tolerance class H7.

Nominal O.D.	Recommended Hole Size
4 to 6	Nominal +0/+0.012
7 to 10	Nominal +0/+0.015
12 to 18	Nominal +0/+0.018
22 to 30	Nominal +0/+0.021
35 to 48	Nominal +0/+0.025
55 to 78	Nominal +0/+0.030
85 to 115	Nominal +0/+0.035
125	Nominal +0/+0.040

Press Fit Bushing Installation

First, lubricate the inside diameter of the mounting hole and the outside diameter of the bushing/liner.

Second, use an arbor press to press the bushing/liner into place. If an arbor press is not available, draw the bushing/liner into place by tightening two steel plates connected by a nut and bolt. Maintain centerline perpendicularity.

Bushing Features

- All bushings that are ground on the O.D. are held within .012 mm concentricity T.I.R. (Total Indicator Reading).
- Longer lengths than standard or excessively counterbored bushings will meet the above tolerances at the drill exit end only.
- All Acme bushings are manufactured with a blended radius at the drill entrance end unless specified otherwise.
- All Press Fit bushings have a chamfer and ground lead on the exit end.
- Standard and Special bushings will be manufactured from thru-hardened tool steel and heat treated to 61-65 Rockwell "C" unless instructed otherwise by the customer.
- No-Counterbore bushings will be supplied unless requested otherwise. No-Counterbore bushings allow for truer alignment, more accurate holes, less tool wear, and less problems with chips packing up in the I.D. of the bushing.

Inside Diameter Tolerances

The minimum and maximum allowance for the Inside Diameter of standard bushings is in accordance with metric tolerance class G6. Special bushings will be supplied with the tolerances shown, unless specified otherwise.

Standard Drill Bushings:

I.D. Range (Drill Size)	Standard I.D. Tolerance (add to nominal I.D.)
0.35 to 3.00	+0.002 to +0.008
3.01 to 6.00	+0.004 to +0.012
6.01 to 10.00	+0.005 to +0.014
10.01 to 18.00	+0.006 to +0.017
18.01 to 30.00	+0.007 to +0.020
30.01 to 50.00	+0.009 to +0.025
50.01 to 80.00	+0.010 to +0.029
80.01 to 105.00	+0.012 to +0.034

Reamer Bushings:

I.D. Range (Reamer Size)	I.D. Tolerance (add to nominal I.D.)
1.00 to 3.00	+0.006 to +0.012
3.01 to 6.00	+0.010 to +0.018
6.01 to 10.00	+0.013 to +0.022
10.01 to 18.00	+0.016 to +0.027
18.01 to 30.00	+0.020 to +0.033

Reamer Bushings are considered specials and are priced accordingly. When ordering specify the letters "RM" after the I.D.

Outside Diameter Tolerances

The minimum and maximum metric tolerance for the Outside Diameter of standard press fit bushings is class s6 and class h5 for slip-fixed renewable bushings.

Ordering Information

To order metric bushings please provide the quantity required, ANSI Symbol, and inside diameter. The order for 26 pieces of a 38 mm I.D., by 55 mm O.D., by 30 mm long, Type PM bushing should appear as follows:

Qty.	Type	O.D. (in mm)	Lgth. (in mm)	I.D. (in mm)
26 pcs.	PM	55	30	38.00



Standard Metric Bushings

Plain Press Fit



Type PM



All press fit bushings are lapped, honed or ground in the I.D. and are concentric within .012 T.I.R. to the O.D.

Please order by providing the ANSI symbol and I.D. size. Example: 9mm I.D. X 15mm O.D. X 20mm Long Type PM, order as PM-15-20-9.00

No-Counterbore bushings are standard with Acme.

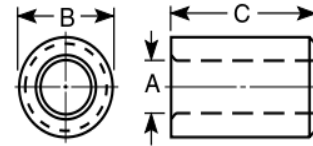

A Inside Diameter Range of Standard Drill Sizes	B Outside Diameter (Actual O.D.)	C Length Overall	ANSI Symbol Type "PM"
0.35 thru 1.00	4 (4.027 / 4.019)	6	PM-4-6 PM-4-9
1.01 thru 1.80		9	
1.81 thru 2.60	5 (5.027 / 5.019)	6	PM-5-6 PM-5-9
		9	
2.61 thru 3.30	6 (6.027 / 6.019)	8	PM-6-8 PM-6-12 PM-6-16
		12	
		16	
3.31 thru 4.00	7 (7.032 / 7.023)	8	PM-7-8 PM-7-12 PM-7-16
		12	
		16	
4.01 thru 5.00	8 (8.032 / 8.023)	8	PM-8-8 PM-8-12 PM-8-16
		12	
		16	
5.01 thru 6.00	10 (10.032 / 10.023)	10	PM-10-10 PM-10-16 PM-10-20
		16	
		20	
6.01 thru 8.00	12 (12.039 / 12.028)	10	PM-12-10 PM-12-16 PM-12-20
		16	
		20	
8.01 thru 10.00	15 (15.039 / 15.028)	12	PM-15-12 PM-15-20 PM-15-25
		20	
		25	
10.01 thru 12.00	18 (18.039 / 18.028)	12	PM-18-12 PM-18-20 PM-18-25
		20	
		25	
12.01 thru 15.00	22 (22.048 / 22.035)	16	PM-22-16 PM-22-28 PM-22-36
		28	
		36	
15.01 thru 18.00	26 (26.048 / 26.035)	16	PM-26-16 PM-26-28 PM-26-36
		28	
		36	
18.01 thru 22.00	30 (30.048 / 30.035)	20	PM-30-20 PM-30-36 PM-30-45
		36	
		45	
22.01 thru 26.00	35 (35.059 / 35.043)	20	PM-35-20 PM-35-36 PM-35-45
		36	
		45	

Std. Metric Drill Sizes		
0.35	3.40	8.25
0.38	3.50	8.30
0.40	3.60	8.40
0.42	3.70	8.50
0.45	3.75	8.60
0.48	3.80	8.70
0.50	3.90	8.75
0.55	4.00	8.80
0.60	4.10	8.90
0.65	4.20	9.00
0.70	4.25	9.10
0.75	4.30	9.20
0.80	4.40	9.25
0.85	4.50	9.30
0.90	4.60	9.40
0.95	4.70	9.50
1.00	4.75	9.60
1.05	4.80	9.70
1.10	4.90	9.75
1.15	5.00	9.80
1.20	5.10	9.90
1.25	5.20	10.0
1.30	5.25	10.2
1.35	5.30	10.5
1.40	5.40	10.8
1.45	5.50	11.0
1.50	5.60	11.2
1.55	5.70	11.5
1.60	5.75	11.8
1.65	5.80	12.0
1.70	5.90	12.2
1.75	6.00	12.5
1.80	6.10	13.0
1.85	6.20	13.5
1.90	6.25	14.0
1.95	6.30	14.5
2.00	6.40	15.0
2.05	6.50	15.5
2.10	6.60	16.0
2.15	6.70	16.5
2.20	6.75	17.0
2.25	6.80	17.5
2.30	6.90	18.0
2.35	7.00	18.5
2.40	7.10	19.0
2.45	7.20	19.5
2.50	7.25	20.0
2.55	7.30	20.5
2.60	7.40	21.0
2.65	7.50	21.5
2.70	7.60	22.0
2.75	7.70	22.5
2.80	7.75	23.0
2.90	7.80	23.5
3.00	7.90	24.0
3.10	8.00	24.5
3.20	8.10	25.0
3.25	8.20	26.0
3.30		

All dimensions are in millimeters.





Standard Metric Bushings Plain Press Fit

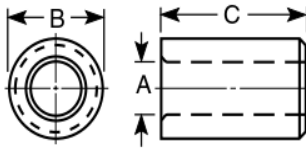

I.D. Range (Drill Size)	Standard I.D. Tolerance (add to nominal I.D.)
0.35 to 3.00	+0.002 to +0.008
3.01 to 6.00	+0.004 to +0.012
6.01 to 10.00	+0.005 to +0.014
10.01 to 18.00	+0.006 to +0.017
18.01 to 30.00	+0.007 to +0.020
30.01 to 50.00	+0.009 to +0.025
50.01 to 80.00	+0.010 to +0.029
80.01 to 105.00	+0.012 to +0.034

Type PM



Std. Metric Drill Sizes
27.0
28.0
29.0
30.0
31.0
32.0
33.0
34.0
35.0
36.0
37.0
38.0
39.0
40.0
41.0
42.0
43.0
44.0
45.0
46.0
47.0
48.0
49.0
50.0
55.0
60.0
65.0
70.0
75.0
80.0
85.0
90.0
95.0
100.0
105.0

A Inside Diameter Range of Standard Drill Sizes	B Outside Diameter (Actual O.D.)	C Length Overall	ANSI Symbol Type "PM"
26.01 thru 30.00	42 (42.059 / 42.043)	25 45 56	PM-42-25 PM-42-45 PM-42-56
30.01 thru 35.00	48 (48.059 / 48.043)	25 45 56	PM-48-25 PM-48-45 PM-48-56
35.01 thru 42.00	55 (55.072 / 55.053)	30 56 67	PM-55-30 PM-55-56 PM-55-67
42.01 thru 48.00	62 (62.072 / 62.053)	30 56 67	PM-62-30 PM-62-56 PM-62-67
48.01 thru 55.00	70 (70.078 / 70.059)	30 56 67	PM-70-30 PM-70-56 PM-70-67
55.01 thru 63.00	78 (78.078 / 78.059)	35 67 78	PM-78-35 PM-78-67 PM-78-78
63.01 thru 70.00	85 (85.093 / 85.071)	35 67 78	PM-85-35 PM-85-67 PM-85-78
70.01 thru 78.00	95 (95.093 / 95.071)	40 78 105	PM-95-40 PM-95-78 PM-95-105
78.01 thru 85.00	105 (105.101 / 105.079)	40 78 105	PM-105-40 PM-105-78 PM-105-105
85.01 thru 95.00	115 (115.101 / 115.079)	45 89 112	PM-115-45 PM-115-89 PM-115-112
95.01 thru 105.00	125 (125.117 / 125.092)	45 89 112	PM-125-45 PM-125-89 PM-125-112

All dimensions are in millimeters.

No-Counterbore (Full Bearing Surface) Bushings are Standard at ACME.

Standard Metric Bushings

Head Press Fit



Type HM



All press fit bushings are lapped, honed or ground in the I.D. and are concentric within .012 T.I.R. to the O.D.

Please order by providing the ANSI symbol and I.D. size. Example: 9mm I.D. X 15mm O.D. X 20mm Long Type HM, order as HM-15-20-9.00

No-Counterbore bushings are standard with Acme.

Please note that the length on type "HM" bushings is measured overall.

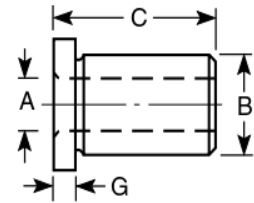

A Inside Diameter Range of Standard Drill Sizes	B Outside Diameter (Actual O.D.)	C Length Overall	ANSI Symbol Type "HM"	Head Dimensions	
				F	G
0.35 thru 1.00	4 (4.027 / 4.019)	6	HM-4-6 HM-4-9	7	2.0
1.01 thru 1.80		9			
1.81 thru 2.60	5 (5.027 / 5.019)	6 9	HM-5-6 HM-5-9	8	2.0
2.61 thru 3.30	6 (6.027 / 6.019)	8 12 16	HM-6-8 HM-6-12 HM-6-16	9	2.5
3.31 thru 4.00	7 (7.032 / 7.023)	8 12 16	HM-7-8 HM-7-12 HM-7-16	10	2.5
4.01 thru 5.00	8 (8.032 / 8.023)	8 12 16	HM-8-8 HM-8-12 HM-8-16	11	2.5
5.01 thru 6.00	10 (10.032 / 10.023)	10 16 20	HM-10-10 HM-10-16 HM-10-20	13	3.0
6.01 thru 8.00	12 (12.039 / 12.028)	10 16 20	HM-12-10 HM-12-16 HM-12-20	15	3.0
8.01 thru 10.00	15 (15.039 / 15.028)	12 20 25	HM-15-12 HM-15-20 HM-15-25	18	3.0
10.01 thru 12.00	18 (18.039 / 18.028)	12 20 25	HM-18-12 HM-18-20 HM-18-25	22	4.0
12.01 thru 15.00	22 (22.048 / 22.035)	16 28 36	HM-22-16 HM-22-28 HM-22-36	26	4.0
15.01 thru 18.00	26 (26.048 / 26.035)	16 28 36	HM-26-16 HM-26-28 HM-26-36	30	4.0
18.01 thru 22.00	30 (30.048 / 30.035)	20 36 45	HM-30-20 HM-30-36 HM-30-45	34	5.0
22.01 thru 26.00	35 (35.059 / 35.043)	20 36 45	HM-35-20 HM-35-36 HM-35-45	39	5.0

Std. Metric Drill Sizes		
0.35	3.40	8.25
0.38	3.50	8.30
0.40	3.60	8.40
0.42	3.70	8.50
0.45	3.75	8.60
0.48	3.80	8.70
0.50	3.90	8.75
0.55	4.00	8.80
0.60	4.10	8.90
0.65	4.20	9.00
0.70	4.25	9.10
0.75	4.30	9.20
0.80	4.40	9.25
0.85	4.50	9.30
0.90	4.60	9.40
0.95	4.70	9.50
1.00	4.75	9.60
1.05	4.80	9.70
1.10	4.90	9.75
1.15	5.00	9.80
1.20	5.10	9.90
1.25	5.20	10.00
1.30	5.25	10.2
1.35	5.30	10.5
1.40	5.40	10.8
1.45	5.50	11.0
1.50	5.60	11.2
1.55	5.70	11.5
1.60	5.75	11.8
1.65	5.80	12.0
1.70	5.90	12.2
1.75	6.00	12.5
1.80	6.10	13.0
1.85	6.20	13.5
1.90	6.25	14.0
1.95	6.30	14.5
2.00	6.40	15.0
2.05	6.50	15.5
2.10	6.60	16.0
2.15	6.70	16.5
2.20	6.75	17.0
2.25	6.80	17.5
2.30	6.90	18.0
2.35	7.00	18.5
2.40	7.10	19.0
2.45	7.20	19.5
2.50	7.25	20.0
2.55	7.30	20.5
2.60	7.40	21.0
2.65	7.50	21.5
2.70	7.60	22.0
2.75	7.70	22.5
2.80	7.75	23.0
2.90	7.80	23.5
3.00	7.90	24.0
3.10	8.00	24.5
3.20	8.10	25.0
3.25	8.20	26.0
3.30		

All dimensions are in millimeters.



Standard Metric Bushings Head Press Fit

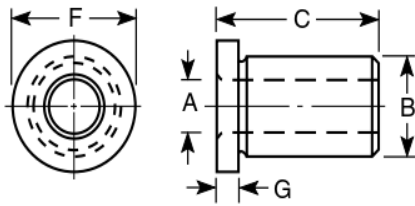

I.D. Range (Drill Size)	Standard I.D. Tolerance (add to nominal I.D.)
0.35 to 3.00	+0.002 to +0.008
3.01 to 6.00	+0.004 to +0.012
6.01 to 10.00	+0.005 to +0.014
10.01 to 18.00	+0.006 to +0.017
18.01 to 30.00	+0.007 to +0.020
30.01 to 50.00	+0.009 to +0.025
50.01 to 80.00	+0.010 to +0.029
80.01 to 105.00	+0.012 to +0.034

Type HM



Std. Metric Drill Sizes
27.0
28.0
29.0
30.0
31.0
32.0
33.0
34.0
35.0
36.0
37.0
38.0
39.0
40.0
41.0
42.0
43.0
44.0
45.0
46.0
47.0
48.0
49.0
50.0
55.0
60.0
65.0
70.0
75.0
80.0
85.0
90.0
95.0
100.0
105.0

A Inside Diameter Range of Standard Drill Sizes	B Outside Diameter (Actual O.D.)	C Length Overall	ANSI Symbol Type "HM"	Head Dimensions	
				F	G
26.01 thru 30.00	42 (42.059 / 42.043)	25	HM-42-25 HM-42-45 HM-42-56	46	5.0
		45			
		56			
30.01 thru 35.00	48 (48.059 / 48.043)	25	HM-48-25 HM-48-45 HM-48-56	52	5.0
		45			
		56			
35.01 thru 42.00	55 (55.072 / 55.053)	30	HM-55-30 HM-55-56 HM-55-67	59	5.0
		56			
		67			
42.01 thru 48.00	62 (62.072 / 62.053)	30	HM-62-30 HM-62-56 HM-62-67	66	6.0
		56			
		67			
48.01 thru 55.00	70 (70.078 / 70.059)	30	HM-70-30 HM-70-56 HM-70-67	74	6.0
		56			
		67			
55.01 thru 63.00	78 (78.078 / 78.059)	35	HM-78-35 HM-78-67 HM-78-78	82	6.0
		67			
		78			
63.01 thru 70.00	85 (85.093 / 85.071)	35	HM-85-35 HM-85-67 HM-85-78	90	6.0
		67			
		78			
70.01 thru 78.00	95 (95.093 / 95.071)	40	HM-95-40 HM-95-78 HM-95-105	100	6.0
		78			
		105			
78.01 thru 85.00	105 (105.101 / 105.079)	40	HM-105-40 HM-105-78 HM-105-105	110	6.0
		78			
		105			
85.01 thru 95.00	115 (115.101 / 115.079)	45	HM-115-45 HM-115-89 HM-115-112	120	6.0
		89			
		112			
95.01 thru 105.00	125 (125.117 / 125.092)	45	HM-125-45 HM-125-89 HM-125-112	130	6.0
		89			
		112			

All dimensions are in millimeters.

No-Counterbore (Full Bearing Surface) Bushings are Standard at ACME.

Standard Metric Bushings

Slip-Fixed Renewable



Type SFM



All type "SFM" bushings are lapped, honed or ground in the I.D. and are concentric within .012 T.I.R. to the O.D. A slip fit clearance is provided for proper alignment when inserted into a liner.

Please order by providing the ANSI symbol and I.D. size. Example: 8.5 mm I.D. X 15 mm O.D. X 28 mm Long Type SFM, order as SFM-15-28-8.50

No-Counterbore bushings are standard with Acme.

Please note that the length on type "SFM" bushings is measured under the head.

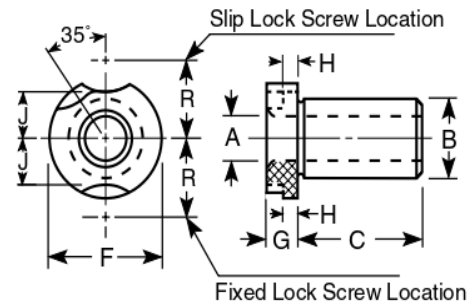

A Inside Diameter Range of Standard Drill Sizes	B Outside Diameter (Actual O.D.)	C Length Under Head	ANSI Symbol Type "SFM"	Head Dimensions					Lock Screws and Clamps
				F	G	H	J	R	
0.35 thru 1.00	8 (8.000 / 7.994)	10 16	SFM-8-10 SFM-8-16	15	6	3.0	4.5	11.5	LSM-1 or 2 RCM-1 or 2
1.01 thru 1.80									
1.81 thru 4.00									
4.01 thru 6.00	10 (10.000 / 9.994)	12 20 25	SFM-10-12 SFM-10-20 SFM-10-25	18	6	3.0	6.0	13.0	LSM-1 or 2 RCM-1 or 2
6.01 thru 8.00	12 (12.000 / 11.992)	12 20 25	SFM-12-12 SFM-12-20 SFM-12-25	22	8	4.0	7.5	16.0	LSM-3 or 4 RCM-3 or 4
8.01 thru 10.00	15 (15.000 / 14.992)	16 28 36	SFM-15-16 SFM-15-28 SFM-15-36	26	8	4.0	9.5	18.0	LSM-3 or 4 RCM-3 or 4
10.01 thru 12.00	18 (18.000 / 17.992)	16 28 36	SFM-18-16 SFM-18-28 SFM-18-36	30	8	4.0	11.5	20.0	LSM-3 or 4 RCM-3 or 4
12.01 thru 15.00	22 (22.000 / 21.991)	20 36 45	SFM-22-20 SFM-22-36 SFM-22-45	34	10	5.5	13.0	23.5	LSM-5 or 6 RCM-5 or 6
15.01 thru 18.00	26 (26.000 / 25.991)	20 36 45	SFM-26-20 SFM-26-36 SFM-26-45	39	10	5.5	15.5	26.0	LSM-5 or 6 RCM-5 or 6
18.01 thru 22.00	30 (30.000 / 29.991)	25 45 56	SFM-30-25 SFM-30-45 SFM-30-56	46	10	5.5	19.0	29.5	LSM-5 or 6 RCM-5 or 6
22.01 thru 26.00	35 (35.000 / 34.989)	25 45 56	SFM-35-25 SFM-35-45 SFM-35-56	52	10	5.5	22.0	32.5	LSM-5 or 6 RCM-5 or 6
26.01 thru 30.00	42 (42.000 / 41.989)	30 56 67	SFM-42-30 SFM-42-56 SFM-42-67	59	10	5.5	25.5	36.0	LSM-5 or 6 RCM-5 or 6
30.01 thru 35.00	48 (48.000 / 47.989)	30 56 67	SFM-48-30 SFM-48-56 SFM-48-67	66	12	7.0	28.5	41.0	LSM-7 or 8 RCM-7 or 8

Std. Metric Drill Sizes		
0.35	3.70	8.75
0.38	3.75	8.80
0.40	3.80	8.90
0.42	3.90	9.00
0.45	4.00	9.10
0.48	4.10	9.20
0.50	4.20	9.25
0.55	4.25	9.30
0.60	4.30	9.40
0.65	4.40	9.50
0.70	4.50	9.60
0.75	4.60	9.70
0.80	4.70	9.75
0.85	4.75	9.80
0.90	4.80	9.90
0.95	4.90	10.0
1.00	5.00	10.2
1.05	5.10	10.5
1.10	5.20	10.8
1.15	5.25	11.0
1.20	5.30	11.2
1.25	5.40	11.5
1.30	5.50	11.8
1.35	5.60	12.0
1.40	5.70	12.2
1.45	5.75	12.5
1.50	5.80	13.0
1.55	5.90	13.5
1.60	6.00	14.0
1.65	6.10	14.5
1.70	6.20	15.0
1.75	6.25	15.5
1.80	6.30	16.0
1.85	6.40	16.5
1.90	6.50	17.0
1.95	6.60	17.5
2.00	6.70	18.0
2.05	6.75	18.5
2.10	6.80	19.0
2.15	6.90	19.5
2.20	7.00	20.0
2.25	7.10	20.5
2.30	7.20	21.0
2.35	7.25	21.5
2.40	7.30	22.0
2.45	7.40	22.5
2.50	7.50	23.0
2.55	7.60	23.5
2.60	7.70	24.0
2.65	7.75	24.5
2.70	7.80	25.0
2.75	7.90	26.0
2.80	8.00	27.0
2.90	8.10	28.0
3.00	8.20	29.0
3.10	8.25	30.0
3.20	8.30	31.0
3.25	8.40	32.0
3.30	8.50	33.0
3.40	8.60	34.0
3.50	8.70	35.0
3.60		

All dimensions are in millimeters.





Standard Metric Bushings Slip-Fixed Renewable

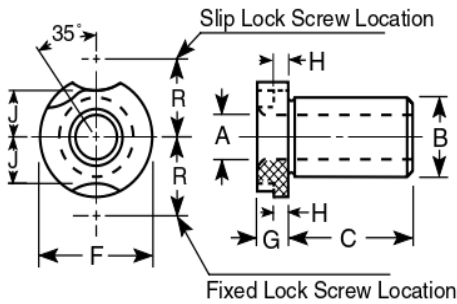

I.D. Range (Drill Size)	Standard I.D. Tolerance (add to nominal I.D.)
0.35 to 3.00	+0.002 to +0.008
3.01 to 6.00	+0.004 to +0.012
6.01 to 10.00	+0.005 to +0.014
10.01 to 18.00	+0.006 to +0.017
18.01 to 30.00	+0.007 to +0.020
30.01 to 50.00	+0.009 to +0.025
50.01 to 80.00	+0.010 to +0.029
80.01 to 105.00	+0.012 to +0.034

Type SFM



Std. Metric Drill Sizes
36.0
37.0
38.0
39.0
40.0
41.0
42.0
43.0
44.0
45.0
46.0
47.0
48.0
49.0
50.0
55.0
60.0
65.0
70.0
75.0
80.0
85.0
90.0
95.0
100.0
105.0

A Inside Diameter Range of Standard Drill Sizes	B Outside Diameter (Actual O.D.)	C Length Under Head	ANSI Symbol Type "SFM"	Head Dimensions					Lock Screws and Clamps
				F	G	H	J	R	
35.01 thru 42.00	55 (55.000 / 54.987)	30 56 67	SFM-55-30 SFM-55-56 SFM-55-67	74	12	7.0	32.5	45.0	LSM-7 or 8 RCM-7 or 8
42.01 thru 48.00	62 (62.000 / 61.987)	35 67 78	SFM-62-35 SFM-62-67 SFM-62-78	82	12	7.0	36.5	49.0	LSM-7 or 8 RCM-7 or 8
48.01 thru 55.00	70 (70.000 / 69.987)	35 67 78	SFM-70-35 SFM-70-67 SFM-70-78	90	12	7.0	40.5	53.0	LSM-7 or 8 RCM-7 or 8
55.01 thru 62.00	78 (78.000 / 77.987)	40 78 105	SFM-78-40 SFM-78-78 SFM-78-105	100	12	7.0	45.5	58.0	LSM-7 or 8 RCM-7 or 8
62.01 thru 70.00	85 (85.000 / 84.985)	40 78 105	SFM-85-40 SFM-85-78 SFM-85-105	110	12	7.0	50.5	63.0	LSM-7 or 8 RCM-7 or 8
70.01 thru 78.00	95 (95.000 / 94.985)	45 89 112	SFM-95-45 SFM-95-89 SFM-95-112	120	12	7.0	55.5	68.0	LSM-7 or 8 RCM-7 or 8
78.01 thru 85.00	105 (105.000 / 104.985)	45 89 112	SFM-105-45 SFM-105-89 SFM-105-112	130	12	7.0	60.5	73.0	LSM-7 or 8 RCM-7 or 8

All dimensions are in millimeters.

No-Counterbore (Full Bearing Surface) Bushings are Standard at ACME.

Standard Metric Bushings

Plain Liners



Type PM



All liners are honed or ground in the I.D. and are concentric within .012 T.I.R. to the O.D.

Please order by providing the ANSI symbol and I.D. size. Example: 15mm I.D. X 22mm O.D. X 28mm Long Type PM, order as PM-22-28-15.00

No-Counterbore bushings are standard with Acme.

Plain Liners are dimensionally the same as Plain Press Fit Bushings so they both have the same type "PM" designation. Some catalogs may refer to Plain Liners as type "LM".

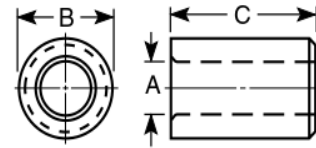

A Inside Diameter (Actual I.D.)	B Outside Diameter (Actual O.D.)	C Length Overall	ANSI Symbol Type "PM"
8.00 (8.005 / 8.014)	12 (12.039 / 12.028)	10 16	PM-12-10-8.00 PM-12-16-8.00
10.00 (10.005 / 10.014)	15 (15.039 / 15.028)	12 20 25	PM-15-12-10.00 PM-15-20-10.00 PM-15-25-10.00
12.00 (12.006 / 12.017)	18 (18.039 / 18.028)	12 20 25	PM-18-12-12.00 PM-18-20-12.00 PM-18-25-12.00
15.00 (15.006 / 15.017)	22 (22.048 / 22.035)	16 28 36	PM-22-16-15.00 PM-22-28-15.00 PM-22-36-15.00
18.00 (18.006 / 18.017)	26 (26.048 / 26.035)	16 28 36	PM-26-16-18.00 PM-26-28-18.00 PM-26-36-18.00
22.00 (22.007 / 22.020)	30 (30.048 / 30.035)	20 36 45	PM-30-20-22.00 PM-30-36-22.00 PM-30-45-22.00
26.00 (26.007 / 26.020)	35 (35.059 / 35.043)	20 36 45	PM-35-20-26.00 PM-35-36-26.00 PM-35-45-26.00
30.00 (30.007 / 30.020)	42 (42.059 / 42.043)	25 45 56	PM-42-25-30.00 PM-42-45-30.00 PM-42-56-30.00
35.00 (35.009 / 35.025)	48 (48.059 / 48.043)	25 45 56	PM-48-25-35.00 PM-48-45-35.00 PM-48-56-35.00
42.00 (42.009 / 42.025)	55 (55.072 / 55.053)	30 56 67	PM-55-30-42.00 PM-55-56-42.00 PM-55-67-42.00
48.00 (48.009 / 48.025)	62 (62.072 / 62.053)	30 56 67	PM-62-30-48.00 PM-62-56-48.00 PM-62-67-48.00

All dimensions are in millimeters.



Standard Metric Bushings Plain Liners

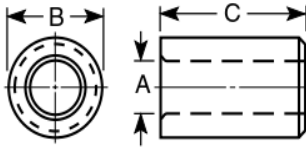

Plain Liners are dimensionally the same as Plain Press Fit Bushings so they both have the same type “PM” designation. Some catalogs may refer to Plain Liners as type “LM”.

Type PM



A Inside Diameter (Actual I.D.)	B Outside Diameter (Actual O.D.)	C Length Overall	ANSI Symbol Type “PM”
55.00 (55.010 / 55.029)	70 (70.078 / 70.059)	30 56 67	PM-70-30-55.00 PM-70-56-55.00 PM-70-67-55.00
62.00 (62.010 / 62.029)	78 (78.078 / 78.059)	35 67 78	PM-78-35-62.00 PM-78-67-62.00 PM-78-78-62.00
70.00 (70.010 / 70.029)	85 (85.093 / 85.071)	35 67 78	PM-85-35-70.00 PM-85-67-70.00 PM-85-78-70.00
78.00 (78.010 / 78.029)	95 (95.093 / 95.071)	40 78 105	PM-95-40-78.00 PM-95-78-78.00 PM-95-105-78.00
85.00 (85.012 / 85.034)	105 (105.101 / 105.079)	40 78 105	PM-105-40-85.00 PM-105-78-85.00 PM-105-105-85.00
95.00 (95.012 / 95.034)	115 (115.101 / 115.079)	45 89 112	PM-115-45-95.00 PM-115-89-95.00 PM-115-112-95.00
105.00 (105.012 / 105.034)	125 (125.117 / 125.092)	45 89 112	PM-125-45-105.00 PM-125-89-105.00 PM-125-112-105.00

All dimensions are in millimeters.

No-Counterbore (Full Bearing Surface) Bushings are Standard at ACME.



Get quote »

Angic Global Solutions

1-888-872-0690

Phone

7-428-1820 •

<https://www.AngicGlobal.com> Sales@AngicGlobal.com

Standard Metric Bushings Head Liners



Type HM



All Head Liners are honed or ground in the I.D. and are concentric within .012 T.I.R. to the O.D.

Please order by providing the ANSI symbol and I.D. size. Example: 18mm I.D. X 26mm O.D. X 16mm Long Type HM, order as HM-26-16-18.00

No-Counterbore bushings are standard with Acme.

Head Liners are dimensionally the same as Head Press Fit Bushings so they both have the same type "HM" designation. Some catalogs may refer to Head Liners as type "HLM".

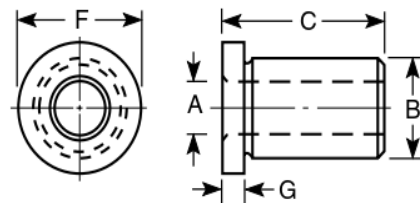

A Inside Diameter (Actual I.D.)	B Outside Diameter (Actual O.D.)	C Length Overall	ANSI Symbol Type "HM"	Head Dimensions	
				F	G
8 (8.005 / 8.014)	12 (12.039 / 12.028)	10 16	HM-12-10-8.00 HM-12-16-8.00	15	3.0
10 (10.005 / 10.014)	15 (15.039 / 15.028)	12 20 25	HM-15-12-10.00 HM-15-20-10.00 HM-15-25-10.00	18	3.0
12 (12.006 / 12.017)	18 (18.039 / 18.028)	12 20 25	HM-18-12-12.00 HM-18-20-12.00 HM-18-25-12.00	22	4.0
15 (15.006 / 15.017)	22 (22.048 / 22.035)	16 28 36	HM-22-16-15.00 HM-22-28-15.00 HM-22-36-15.00	26	4.0
18 (18.006 / 18.017)	26 (26.048 / 26.035)	16 28 36	HM-26-16-18.00 HM-26-28-18.00 HM-26-36-18.00	30	4.0
22 (22.007 / 22.020)	30 (30.048 / 30.035)	20 36 45	HM-30-20-22.00 HM-30-36-22.00 HM-30-45-22.00	34	5.0
26 (26.007 / 26.020)	35 (35.059 / 35.043)	20 36 45	HM-35-20-26.00 HM-35-36-26.00 HM-35-45-26.00	39	5.0
30 (30.007 / 30.020)	42 (42.059 / 42.043)	25 45 56	HM-42-25-30.00 HM-42-45-30.00 HM-42-56-30.00	46	5.0
35 (35.009 / 35.025)	48 (48.059 / 48.043)	25 45 56	HM-48-25-35.00 HM-48-45-35.00 HM-48-56-35.00	52	5.0
42 (42.009 / 42.025)	55 (55.072 / 55.053)	30 56 67	HM-55-30-42.00 HM-55-56-42.00 HM-55-67-42.00	59	5.0
48 (48.009 / 48.025)	62 (62.072 / 62.053)	30 56 67	HM-62-30-48.00 HM-62-56-48.00 HM-62-67-48.00	66	6.0

All dimensions are in millimeters.



Standard Metric Bushings Head Liners

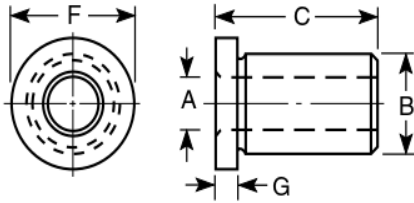

Head Liners are dimensionally the same as Head Press Fit Bushings so they both have the same type designation "HM". Some catalogs may refer to Head Liners as type "HLM". Please note that the length on type "HM" bushings and liners is measured overall.

Type HM



A Inside Diameter Range of Standard Drill Sizes	B Outside Diameter (Actual O.D.)	C Length Overall	ANSI Symbol Type "HM"	Head Dimensions	
				F	G
55 (55.010 / 55.029)	70 (70.078 / 70.059)	30 56 67	HM-70-30-55.00 HM-70-56-55.00 HM-70-67-55.00	74	6.0
62 (62.010 / 62.029)	78 (78.078 / 78.059)	35 67 78	HM-78-35-62.00 HM-78-67-62.00 HM-78-78-62.00	82	6.0
70 (70.010 / 70.029)	85 (85.093 / 85.071)	35 67 78	HM-85-35-70.00 HM-85-67-70.00 HM-85-78-70.00	90	6.0
78 (78.010 / 78.029)	95 (95.093 / 95.071)	40 78 105	HM-95-40-78.00 HM-95-78-78.00 HM-95-105-78.00	100	6.0
85 (85.012 / 85.034)	105 (105.101 / 105.079)	40 78 105	HM-105-40-85.00 HM-105-78-85.00 HM-105-105-85.00	110	6.0
95 (95.012 / 95.034)	115 (115.101 / 115.079)	45 89 112	HM-115-45-95.00 HM-115-89-95.00 HM-115-112-95.00	120	6.0
105 (105.012 / 105.034)	125 (125.117 / 125.092)	45 89 112	HM-125-45-105.00 HM-125-89-105.00 HM-125-112-105.00	130	6.0

All dimensions are in millimeters.

No-Counterbore (Full Bearing Surface) Bushings are Standard at ACME.



Get quote »

Angic Global Solutions

1-888-872-0690

Phone

7-428-1820 •

<https://www.AngicGlobal.com> Sales@AngicGlobal.com

Standard Metric Lockscrews & Clamps



Lock Screws



Standard Mounting

Symbol	G	H	I	J	L	Thread
LSM-1	6	3.0	7.5	13	9	M5x0.8
LSM-3	8	4.0	9.5	16	10	M6x1.0
LSM-5	10	5.5	12.0	20	12	M8x1.25
LSM-7	12	7.0	15.0	24	20	M10x1.5

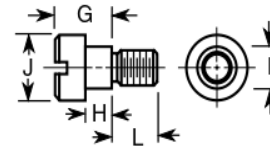

Projected Mounting

Symbol	G	H	I	J	L	Thread
LSM-2	9	6.0	7.5	13	9	M5x0.8
LSM-4	12	8.0	9.5	16	10	M6x1.0
LSM-6	15	10.5	12.0	20	12	M8x1.25
LSM-8	18	13.0	15.0	24	20	M10x1.5

All dimensions are in millimeters.



Round Clamps

Standard Mounting

Symbol	A	B	C	D	E	F	H	K	Used With Thread
RCM-1	13	8	10	4	9.5	3.7	3.0	5.4	M5x0.8
RCM-3	16	10	12	5	15.0	4.7	4.0	6.4	M6x1.0
RCM-5	20	12	15	5	30.0	6.2	5.5	8.4	M8x1.25
RCM-7	24	16	18	7	80.0	7.5	7.0	10.5	M10x1.5

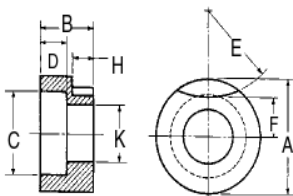

Projected Mounting

Symbol	A	B	C	D	E	F	H	K	Used With Thread
RCM-2	13	11	10	4	9.5	3.7	6.0	5.4	M5x0.8
RCM-4	16	14	12	5	15.0	4.7	8.0	6.4	M6x1.0
RCM-6	20	17	15	5	30.0	6.2	10.5	8.4	M8x1.25
RCM-8	24	22	18	7	80.0	7.5	13.0	10.5	M10x1.5

All dimensions are in millimeters.

Shop Acme Bushings Online

store.acmeindustrial.com

Pricing and volume discounts for



Standard Drill Bushings – *Inch*

- Nearly 5000 ANSI Standards
- Nearly 8000 Acme Standards
- P, H, SF, L and HL



Standard Drill Bushings – *Metric*

- Nearly 2000 ANSI Standards
- PM, HM, SFM, Plain Liners (PM) and Head Liners (HM)



***The Standard Components
With the Highest Standards***



Get quote »

Angic Global Solutions

1-888-872-0690

<https://www.AngicGlobal.com> Sales@AngicGlobal.com



DECIMAL CONVERSION CHART

Decimal Equivalents of Fraction, Wire, and Letter Sizes

Size	Decimal	Size	Decimal	Size	Decimal	Size	Decimal	Size	Decimal	Size	Decimal
80.....	.0135	5/64.....	.0781	17.....	.1730	N.....	.3020	11/16.....	.6875	1-17/64.....	1.2656
79.....	.0145	47.....	.0785	16.....	.1770	5/16.....	.3125	45/64.....	.7031	1-9/32.....	1.2812
1/64.....	.0156	46.....	.0810	15.....	.1800	O.....	.3160	23/32.....	.7188	1-19/64.....	1.2969
78.....	.0160	45.....	.0820	14.....	.1820	P.....	.3230	47/64.....	.7344	1-5/16.....	1.3125
77.....	.0180	44.....	.0860	13.....	.1850	21/64.....	.3281	3/4.....	.7500	1-21/64.....	1.3281
76.....	.0200	43.....	.0890	3/16.....	.1875	Q.....	.3320	49/64.....	.7656	1-11/32.....	1.3438
75.....	.0210	42.....	.0935	12.....	.1890	R.....	.3390	25/32.....	.7812	1-23/64.....	1.3594
74.....	.0225	3/32.....	.0938	11.....	.1910	11/32.....	.3438	51/64.....	.7969	1-3/8.....	1.3750
73.....	.0240	41.....	.0960	10.....	.1935	S.....	.3480	13/16.....	.8125	1-25/64.....	1.3906
72.....	.0250	40.....	.0980	9.....	.1960	T.....	.3580	53/64.....	.8281	1-13/32.....	1.4062
71.....	.0260	39.....	.0995	8.....	.1990	23/64.....	.3594	27/32.....	.8438	1-27/64.....	1.4219
70.....	.0280	38.....	.1015	7.....	.2010	U.....	.3680	55/64.....	.8594	1-7/16.....	1.4375
69.....	.0292	37.....	.1040	13/64.....	.2031	3/8.....	.3750	7/8.....	.8750	1-29/64.....	1.4531
68.....	.0310	36.....	.1065	6.....	.2040	V.....	.3770	57/64.....	.8906	1-15/32.....	1.4688
67.....	.0320	35.....	.1100	5.....	.2055	W.....	.3860	29/32.....	.9062	1-31/64.....	1.4844
66.....	.0330	34.....	.1110	4.....	.2090	25/64.....	.3906	59/64.....	.9219	1-1/2.....	1.5000
65.....	.0350	33.....	.1130	3.....	.2130	X.....	.3970	15/16.....	.9375	1-33/64.....	1.5156
64.....	.0360	32.....	.1160	7/32.....	.2188	Y.....	.4040	61/64.....	.9531	1-17/32.....	1.5312
63.....	.0370	31.....	.1200	2.....	.2210	13/32.....	.4062	31/32.....	.9688	1-35/64.....	1.5469
62.....	.0380	1/8.....	.1250	1.....	.2280	Z.....	.4130	63/64.....	.9844	1-9/16.....	1.5625
61.....	.0390	30.....	.1285	A.....	.2340	27/64.....	.4219	1".....	1.0000	1-37/64.....	1.5781
60.....	.0400	29.....	.1360	15/64.....	.2344	7/16.....	.4375	1-1/64.....	1.0156	1-19/32.....	1.5938
59.....	.0410	28.....	.1405	B.....	.2380	29/64.....	.4531	1-1/32.....	1.0312	1-39/64.....	1.6094
58.....	.0420	9/64.....	.1406	C.....	.2420	15/32.....	.4688	1-3/64.....	1.0469	1-5/8.....	1.6250
57.....	.0430	27.....	.1440	D.....	.2460	31/64.....	.4844	1-1/16.....	1.0625	1-41/64.....	1.6406
56.....	.0465	26.....	.1470	1/4.....	.2500	1/2.....	.5000	1-5/64.....	1.0781	1-21/32.....	1.6562
3/64.....	.0469	25.....	.1495	F.....	.2570	33/64.....	.5156	1-3/32.....	1.0938	1-43/64.....	1.6719
55.....	.0520	24.....	.1520	G.....	.2610	17/32.....	.5312	1-7/64.....	1.1094	1-11/16.....	1.6875
54.....	.0550	23.....	.1540	17/64.....	.2656	35/64.....	.5469	1-1/8.....	1.1250	1-45/64.....	1.7031
53.....	.0595	5/32.....	.1562	H.....	.2660	9/16.....	.5625	1-9/64.....	1.1406	1-23/32.....	1.7188
1/16.....	.0625	22.....	.1570	I.....	.2720	37/64.....	.5781	1-5/32.....	1.1562	1-47/64.....	1.7344
52.....	.0635	J.....	.2770	J.....	.2770	19/32.....	.5938	1-11/64.....	1.1719	1-3/4.....	1.7500
51.....	.0670	21.....	.1590	K.....	.2810	39/64.....	.6094	1-3/16.....	1.1875	2-1/4.....	2.2500
50.....	.0700	20.....	.1610	9/32.....	.2812	5/8.....	.6250	1-13/64.....	1.2031		
49.....	.0730	19.....	.1660	L.....	.2900	41/64.....	.6406	1-7/32.....	1.2188		
48.....	.0760	18.....	.1695	M.....	.2950	21/32.....	.6562	1-15/64.....	1.2344		
		11/64.....	.1719	19/64.....	.2969	43/64.....	.6719	1-1/4.....	1.2500		

Decimal Equivalents of Millimeter Sizes

mm	Decimal	mm	Decimal	mm	Decimal	mm	Decimal	mm	Decimal	mm	Decimal
.35.....	.0138	1.95.....	.0768	4.30.....	.1693	7.25.....	.2854	10.50.....	.4134	27.00.....	1.0630
.38.....	.0150	2.00.....	.0787	4.40.....	.1732	7.30.....	.2874	10.80.....	.4252	28.00.....	1.1024
.40.....	.0157	2.05.....	.0807	4.50.....	.1772	7.40.....	.2913	11.00.....	.4331	29.00.....	1.1417
.42.....	.0165	2.10.....	.0827	4.60.....	.1811	7.50.....	.2953	11.20.....	.4409	30.00.....	1.1811
.45.....	.0177	2.15.....	.0846	4.70.....	.1850	7.60.....	.2992	11.50.....	.4528	31.00.....	1.2205
.48.....	.0189	2.20.....	.0866	4.75.....	.1870	7.70.....	.3031	11.80.....	.4646	32.00.....	1.2598
.50.....	.0197	2.25.....	.0886	4.80.....	.1890	7.75.....	.3051	12.00.....	.4724	33.00.....	1.2992
.55.....	.0217	2.30.....	.0906	4.90.....	.1929	7.80.....	.3071	12.20.....	.4803	34.00.....	1.3386
.60.....	.0236	2.35.....	.0925	5.00.....	.1969	7.90.....	.3110	12.50.....	.4921	35.00.....	1.3780
.65.....	.0256	2.40.....	.0945	5.10.....	.2008	8.00.....	.3150	13.00.....	.5118	36.00.....	1.4173
.70.....	.0276	2.45.....	.0965	5.20.....	.2047	8.10.....	.3189	13.50.....	.5315	37.00.....	1.4567
.75.....	.0295	2.50.....	.0984	5.25.....	.2067	8.20.....	.3228	14.00.....	.5512	38.00.....	1.4961
.80.....	.0315	2.55.....	.1004	5.30.....	.2087	8.25.....	.3248	14.50.....	.5709	39.00.....	1.5354
.85.....	.0335	2.60.....	.1024	5.40.....	.2126	8.30.....	.3268	15.00.....	.5906	40.00.....	1.5748
.90.....	.0354	2.65.....	.1043	5.50.....	.2165	8.40.....	.3307	15.50.....	.6102	41.00.....	1.6142
.95.....	.0374	2.70.....	.1063	5.60.....	.2205	8.50.....	.3346	16.00.....	.6299	42.00.....	1.6535
1.00.....	.0394	2.75.....	.1083	5.70.....	.2244	8.60.....	.3386	16.50.....	.6496	43.00.....	1.6929
1.05.....	.0413	2.80.....	.1102	5.75.....	.2264	8.70.....	.3425	17.00.....	.6693	44.00.....	1.7323
1.10.....	.0433	2.90.....	.1142	5.80.....	.2283	8.75.....	.3445	17.50.....	.6890	45.00.....	1.7717
1.15.....	.0453	3.00.....	.1181	5.90.....	.2323	8.80.....	.3465	18.00.....	.7087	46.00.....	1.8110
1.20.....	.0472	3.10.....	.1220	6.00.....	.2362	8.90.....	.3504	18.50.....	.7283	47.00.....	1.8504
1.25.....	.0492	3.20.....	.1260	6.10.....	.2402	9.00.....	.3543	19.00.....	.7480	48.00.....	1.8898
1.30.....	.0512	3.25.....	.1280	6.20.....	.2441	9.10.....	.3583	19.50.....	.7677	49.00.....	1.9291
1.35.....	.0531	3.30.....	.1299	6.25.....	.2461	9.20.....	.3622	20.00.....	.7874	50.00.....	1.9685
1.40.....	.0551	3.40.....	.1339	6.30.....	.2480	9.25.....	.3642	20.50.....	.8071	55.00.....	2.1654
1.45.....	.0571	3.50.....	.1378	6.40.....	.2520	9.30.....	.3661	21.00.....	.8268	60.00.....	2.3622
1.50.....	.0591	3.60.....	.1417	6.50.....	.2559	9.40.....	.3701	21.50.....	.8465	65.00.....	2.5591
1.55.....	.0610	3.70.....	.1457	6.60.....	.2598	9.50.....	.3740	22.00.....	.8661	70.00.....	2.7559
1.60.....	.0630	3.75.....	.1476	6.70.....	.2638	9.60.....	.3780	22.50.....	.8858	75.00.....	2.9528
1.65.....	.0650	3.80.....	.1496	6.75.....	.2657	9.70.....	.3819	23.00.....	.9055	80.00.....	3.1496
1.70.....	.0669	3.90.....	.1535	6.80.....	.2677	9.75.....	.3839	23.50.....	.9252	85.00.....	3.3465
1.75.....	.0689	4.00.....	.1575	6.90.....	.2717	9.80.....	.3858	24.00.....	.9449	90.00.....	3.5433
1.80.....	.0709	4.10.....	.1614	7.00.....	.2756	9.90.....	.3898	24.50.....	.9646	95.00.....	3.7402
1.85.....	.0728	4.20.....	.1654	7.10.....	.2795	10.00.....	.3937	25.00.....	.9843	100.00.....	3.9370
1.90.....	.0748	4.25.....	.1673	7.20.....	.2835	10.20.....	.4016	26.00.....	1.0236	105.00.....	4.1339



Acme Industrial Company
Subsidiary of Jergens, Inc.

441 Maple Avenue
Carpentersville, Illinois 60110
(847) 428-3911 • (800) 323-5582 • FAX: (847) 428-1820
E-mail: acmail@acmeindustrial.com

